

**DAIKIN**

# Installation and operation manual

## VRV IV system air conditioner

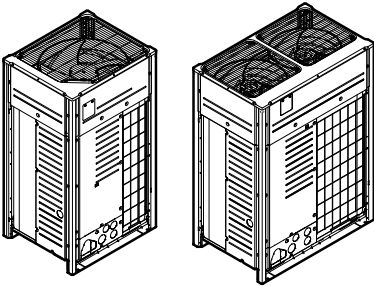

**RYYQ8T7Y1B\***  
**RYYQ10T7Y1B\***  
**RYYQ12T7Y1B\***  
**RYYQ14T7Y1B\***  
**RYYQ16T7Y1B\***  
**RYYQ18T7Y1B\***  
**RYYQ20T7Y1B\***

**RYMQ8T7Y1B\***  
**RYMQ10T7Y1B\***  
**RYMQ12T7Y1B\***  
**RYMQ14T7Y1B\***  
**RYMQ16T7Y1B\***  
**RYMQ18T7Y1B\***  
**RYMQ20T7Y1B\***

**RXYQ8T7Y1B\***  
**RXYQ10T7Y1B\***  
**RXYQ12T7Y1B\***  
**RXYQ14T7Y1B\***  
**RXYQ16T7Y1B\***  
**RXYQ18T7Y1B\***  
**RXYQ20T7Y1B\***







# Table of Contents

## Table of Contents

<b>1 About the documentation</b>	<b>5</b>
1.1 About this document	5

### For the installer **5**

<b>2 About the box</b>	<b>5</b>
2.1 To remove the accessories from the outdoor unit	5
2.2 Accessory pipes: Diameters	5
2.3 To remove the transportation stay	6

<b>3 About the units and options</b>	<b>6</b>
3.1 About the outdoor unit	6
3.2 System layout	6

<b>4 Preparation</b>	<b>6</b>
4.1 Preparing installation site	6
4.1.1 Installation site requirements of the outdoor unit	6
4.1.2 Additional installation site requirements of the outdoor unit in cold climates	7
4.2 Preparing refrigerant piping	7
4.2.1 Refrigerant piping requirements	7
4.2.2 To select the piping size	7
4.2.3 To select refrigerant branch kits	8
4.2.4 Requirements in case of FXTQ indoor units	9
4.2.5 Multiple outdoor units: Possible layouts	10
4.3 Preparing electrical wiring	11
4.3.1 Safety device requirements	11

<b>5 Installation</b>	<b>11</b>
5.1 Opening the units	11
5.1.1 To open the outdoor unit	11
5.1.2 To open the electrical component box of the outdoor unit	11
5.2 Mounting the outdoor unit	12
5.2.1 To provide the installation structure	12
5.3 Connecting the refrigerant piping	12
5.3.1 To route the refrigerant piping	12
5.3.2 To connect the refrigerant piping to the outdoor unit	13
5.3.3 To connect the multi connection piping kit	13
5.3.4 Multiple outdoor units: Knockout holes	13
5.3.5 To protect against contamination	13
5.3.6 Using the stop valve and service port	13
5.3.7 To remove the pinched pipes	14
5.4 Checking the refrigerant piping	15
5.4.1 About checking the refrigerant piping	15
5.4.2 Checking refrigerant piping: General guidelines	15
5.4.3 Checking refrigerant piping: Setup	15
5.4.4 To perform a leak test	16
5.4.5 To perform vacuum drying	16
5.5 To insulate the refrigerant piping	16
5.6 Charging refrigerant	16
5.6.1 Precautions when charging refrigerant	16
5.6.2 About charging refrigerant	17
5.6.3 To determine the additional refrigerant amount	17
5.6.4 To charge refrigerant: Flow chart	19
5.6.5 To charge refrigerant	21
5.6.6 Step 6a: To automatically charge refrigerant	22
5.6.7 Step 6b: To manually charge refrigerant	23
5.6.8 Error codes when charging refrigerant	23
5.6.9 Checks after charging refrigerant	23
5.6.10 To fix the fluorinated greenhouse gases label	23
5.7 Connecting the electrical wiring	23
5.7.1 Field wiring: Overview	23
5.7.2 Guidelines when knocking out knockout holes	24
5.7.3 To route and fix the transmission wiring	24

5.7.4 To connect the transmission wiring	24
5.7.5 To finish the transmission wiring	25
5.7.6 To route and fix the power supply	25
5.7.7 To connect the power supply	25

<b>6 Configuration</b>	<b>26</b>
6.1 Making field settings	26
6.1.1 About making field settings	26
6.1.2 Field setting components	26
6.1.3 To access the field setting components	27
6.1.4 To access mode 1 or 2	27
6.1.5 To use mode 1	27
6.1.6 To use mode 2	27
6.1.7 Mode 1: Monitoring settings	28
6.1.8 Mode 2: Field settings	28
6.1.9 To connect the PC configurator to the outdoor unit	29
6.2 Using the leak detection function	30
6.2.1 About automatic leak detection	30

<b>7 Commissioning</b>	<b>30</b>
7.1 Precautions when commissioning	30
7.2 Checklist before commissioning	30
7.3 About test run	31
7.4 To perform a test run	31
7.5 Correcting after abnormal completion of the test run	32

<b>8 Troubleshooting</b>	<b>32</b>
8.1 Solving problems based on error codes	32
8.2 Error codes: Overview	32

<b>9 Technical data</b>	<b>35</b>
9.1 Service space: Outdoor unit	35
9.2 Piping diagram: Outdoor unit	36

### For the user **37**

<b>10 About the system</b>	<b>37</b>
10.1 System layout	37

<b>11 User interface</b>	<b>37</b>
--------------------------	-----------

<b>12 Operation</b>	<b>37</b>
12.1 Operation range	37
12.2 Operating the system	38
12.2.1 About operating the system	38
12.2.2 About cooling, heating, fan only, and automatic operation	38
12.2.3 About the heating operation	38
12.2.4 To operate the system (WITHOUT cool/heat changeover remote control switch)	38
12.2.5 To operate the system (WITH cool/heat changeover remote control switch)	38
12.3 Using the dry program	39
12.3.1 About the dry program	39
12.3.2 To use the dry program (WITHOUT cool/heat changeover remote control switch)	39
12.3.3 To use the dry program (WITH cool/heat changeover remote control switch)	39
12.4 Adjusting the air flow direction	39
12.4.1 About the air flow flap	39
12.5 Setting the master user interface	39
12.5.1 About setting the master user interface	39

<b>13 Maintenance and service</b>	<b>40</b>
13.1 About the refrigerant	40
13.2 After-sales service and warranty	40
13.2.1 Warranty period	40
13.2.2 Recommended maintenance and inspection	40

<b>14 Troubleshooting</b>	<b>40</b>
14.1 Error codes: Overview	41

14.2	Symptoms that are NOT system malfunctions .....	42
14.2.1	Symptom: The system does not operate .....	42
14.2.2	Symptom: Cool/Heat cannot be changed over .....	42
14.2.3	Symptom: Fan operation is possible, but cooling and heating do not work.....	42
14.2.4	Symptom: The fan strength does not correspond to the setting .....	42
14.2.5	Symptom: The fan direction does not correspond to the setting .....	42
14.2.6	Symptom: White mist comes out of a unit (Indoor unit).....	42
14.2.7	Symptom: White mist comes out of a unit (Indoor unit, outdoor unit) .....	42
14.2.8	Symptom: The user interface display reads "U4" or "U5" and stops, but then restarts after a few minutes .....	42
14.2.9	Symptom: Noise of air conditioners (Indoor unit).....	42
14.2.10	Symptom: Noise of air conditioners (Indoor unit, outdoor unit).....	43
14.2.11	Symptom: Noise of air conditioners (Outdoor unit).....	43
14.2.12	Symptom: Dust comes out of the unit.....	43
14.2.13	Symptom: The units can give off odours.....	43
14.2.14	Symptom: The outdoor unit fan does not spin .....	43
14.2.15	Symptom: The display shows "88".....	43
14.2.16	Symptom: The compressor in the outdoor unit does not stop after a short heating operation .....	43
14.2.17	Symptom: The inside of an outdoor unit is warm even when the unit has stopped .....	43
14.2.18	Symptom: Hot air can be felt when the indoor unit is stopped .....	43

**15 Relocation 43**

**16 Disposal 43**

## 1 About the documentation

### 1.1 About this document

**Target audience**

Authorised installers + end users

## For the installer

## 2 About the box

### 2.1 To remove the accessories from the outdoor unit

Make sure that all accessories are available in the unit.

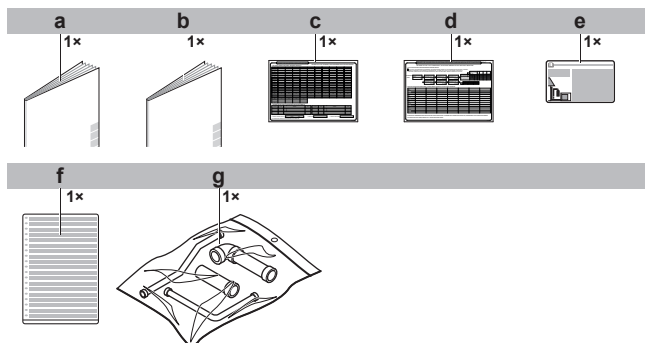

- a General safety precautions
- b Installation manual and operation manual
- c Additional refrigerant charge label

**INFORMATION**

This appliance is intended to be used by expert or trained users in shops, in light industry and on farms, or for commercial use by lay persons.

**Documentation set**

This document is part of a documentation set. The complete set consists of:

- **General safety precautions:**
  - Safety instructions that you must read before installing
  - Format: Paper (in the box of the outdoor unit)
- **Outdoor unit installation and operation manual:**
  - Installation and operation instructions
  - Format: Paper (in the box of the outdoor unit)
- **Installer and user reference guide:**
  - Preparation of the installation, reference data,...
  - Detailed step-by-step instructions and background information for basic and advanced usage
  - Format: Digital files on <http://www.daikineurope.com/support-and-manuals/product-information/>

Latest revisions of the supplied documentation may be available on the regional Daikin website or via your dealer.

The original documentation is written in English. All other languages are translations.

**Technical engineering data**



- A **subset** of the latest technical data is available on the regional Daikin website (publicly accessible).
- The **full set** of latest technical data is available on the Daikin extranet (authentication required).

- d Installation information sticker
- e Fluorinated greenhouse gases label
- f Multilingual fluorinated greenhouse gases label
- g Piping accessory bag

### 2.2 Accessory pipes: Diameters

Accessory pipes (mm)	HP	Øa	Øb
<b>Gas pipe</b>	8	19.1	
▪ Front connection 	10	25.4	22.2
	12	25.4	28.6
▪ Bottom connection 	14		
	16		
	18		
	20		

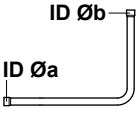
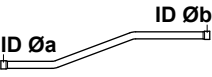
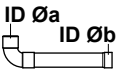
### 3 About the units and options

Accessory pipes (mm)	HP	Øa	Øb
<b>Liquid pipe</b> ▪ Front connection 	8	9.5	
	10		
	12	9.5	12.7
	14	12.7	
	16		
	18	12.7	15.9
▪ Bottom connection 	20		
<b>Equaliser pipe<sup>(a)</sup></b> ▪ Front connection 	8	19.1	
	10		
	12	19.1	22.2
	14		
	16		
	18	25.4	28.6
▪ Bottom connection 	20		

(a) Only for RYMQ models.

### 2.3 To remove the transportation stay

Only for 14~20 HP

#### NOTICE

If the unit is operated with the transportation stay attached, abnormal vibration or noise may be generated.

The transportation stay installed over the compressor leg for protecting the unit during transport must be removed. Proceed as shown in the figure and procedure below.

- Slightly loosen the fixing nut (a).
- Remove the transportation stay (b) as shown in the figure below.
- Tighten the fixing nut (a) again.

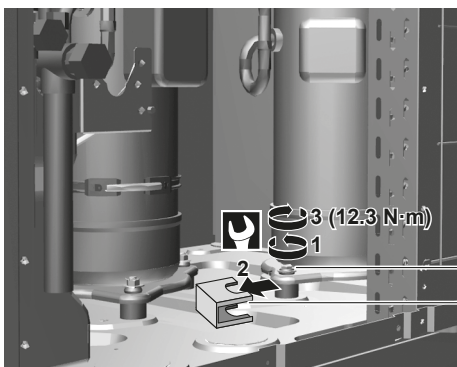

### 3 About the units and options

#### 3.1 About the outdoor unit

This installation manual concerns the VRV IV, full inverter driven, heat pump system.

Model line up:

Model	Description
RYYQ8~20 <sup>(a)</sup>	Single continuous heating model.
RYYQ22~54 <sup>(a)</sup>	Multi continuous heating model (consisting of 2 or 3 RYMQ modules).

Model	Description
RXYQ8~20	Single non-continuous heating model.
RXYQ22~54	Multi non-continuous heating model (consisting of 2 or 3 RXYQ modules).

(a) The RYYQ models provide continuous comfort during defrost operation.

Depending on the type of outdoor unit which is chosen, some functionality will or will not exist. It will be indicated throughout this installation manual and brought to your attention. Certain features have exclusive model rights.

These units are intended for outdoor installation and aimed for heat pump applications including air to air and air to water applications.

These units have (in single use) heating capacities ranging from 25 to 63 kW and cooling capacities rating from 22.4 to 56 kW. In multi combination the heating capacity can go up till 168 kW and in cooling till 150 kW.

The outdoor unit is designed to work in heating mode at ambient temperatures from -20°C WB to 15.5°C WB and in cooling mode at ambient temperatures from -5°C DB to 43°C DB.

### 3.2 System layout

#### INFORMATION

When using FXTQ indoor units, different requirements apply. See "4.2.4 Requirements in case of FXTQ indoor units" on page 9.

#### NOTICE

Design of the system must not be done at temperatures below -15°C.

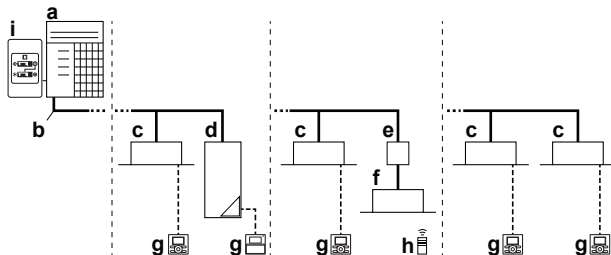

- a VRV IV Heat pump outdoor unit
- b Refrigerant piping
- c VRV direct expansion (DX) indoor unit
- d VRV LT Hydrobox (HXY080/125)
- e BP box (required to connect Residential Air (RA) or Sky Air (SA) direct expansion (DX) indoor units)
- f Residential Air (RA) direct expansion (DX) indoor units
- g User interface (dedicated depending on indoor unit type)
- h User interface (wireless, dedicated depending on indoor unit type)
- i Cool/Heat changeover remote control switch

### 4 Preparation

#### 4.1 Preparing installation site

##### 4.1.1 Installation site requirements of the outdoor unit

Mind the spacing guidelines. See the "Technical data" chapter.



### CAUTION

Appliance not accessible to the general public, install it in a secured area, protected from easy access.

This unit, both indoor and outdoor, is suitable for installation in a commercial and light industrial environment.



### NOTICE

This is a class A product. In a domestic environment this product may cause radio interference in which case the user may be required to take adequate measures.

#### 4.1.2 Additional installation site requirements of the outdoor unit in cold climates



### NOTICE

When operating the unit in a low outdoor ambient temperature with high humidity conditions, make sure to take precautions to keep the drain holes of the unit free by using proper equipment.

In heating:

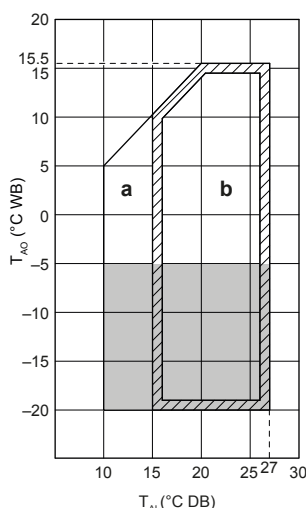

a Warming up operation range

b Operation range

$T_{Ai}$  Ambient indoor temperature

$T_{Ao}$  Ambient outdoor temperature

■ If the unit has to operate for 5 days in this area with high humidity (>90%), Daikin recommends to install the optional heater tape kit (EKBPH012T or EKBPH020T) to keep the drain holes free. If you do so, you also have to install the heater tape PCB kit (EKBPHPCBT).

## 4.2 Preparing refrigerant piping

### 4.2.1 Refrigerant piping requirements



### NOTICE

Refrigerant R410A requires strict cautions for keeping the system clean and dry. Foreign materials (including mineral oils or moisture) should be prevented from getting mixed into the system.



### NOTICE

The piping and other pressure-containing parts shall be suitable for refrigerant. Use phosphoric acid deoxidised seamless copper for refrigerant.

- Foreign materials inside pipes (including oils for fabrication) must be  $\leq 30$  mg/10 m.
- Temper grade: use piping with temper grade in function of the pipe diameter as listed in table below.

Pipe $\varnothing$ (mm)	Temper grade of piping material
$\leq 15.9$	O (annealed)
$\geq 19.1$	1/2H (half hard)

- All piping lengths and distances have been taken into consideration (see About the piping length in the installer reference guide).

### 4.2.2 To select the piping size



### INFORMATION

When using FXTQ indoor units, different requirements apply. See "4.2.4 Requirements in case of FXTQ indoor units" on page 9.

Determine the proper size referring to following tables and reference figure (only for indication).

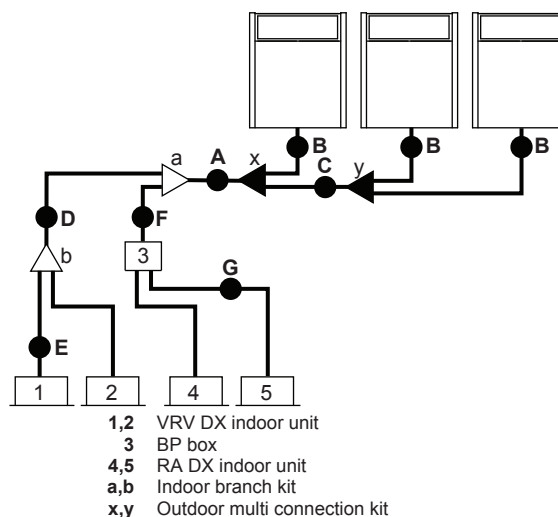

#### A, B, C: Piping between outdoor unit and (first) refrigerant branch kit

Choose from the following table in accordance with the outdoor unit total capacity type, connected downstream.

Outdoor unit capacity type (HP)	Piping outer diameter size (mm)	
	Gas pipe	Liquid pipe
8	19.1	9.5
10	22.2	9.5
12~16	28.6	12.7
18~22	28.6	15.9
24	34.9	15.9
26~34	34.9	19.1
36~54	41.3	19.1

#### D: Piping between refrigerant branch kits

Choose from the following table in accordance with the indoor unit total capacity type, connected downstream. Do not let the connection piping exceed the refrigerant piping size chosen by the general system model name.

## 4 Preparation

Indoor unit capacity index	Piping outer diameter size (mm)	
	Gas pipe	Liquid pipe
<150	15.9	9.5
150≤x<200	19.1	
200≤x<290	22.2	
290≤x<420	28.6	12.7
420≤x<640		15.9
640≤x<920	34.9	19.1
≥920	41.3	

### Example:

- Downstream capacity for E=capacity index of unit 1
- Downstream capacity for D=capacity index of unit 1+capacity index of unit 2

### E: Piping between refrigerant branch kit and indoor unit

Pipe size for direct connection to indoor unit must be the same as the connection size of the indoor unit (in case indoor unit is VRV DX indoor or Hydrobox).

Indoor unit capacity index	Piping outer diameter size (mm)	
	Gas pipe	Liquid pipe
15~50	12.7	6.4
63~140	15.9	9.5
200	19.1	
250	22.2	

- When the equivalent pipe length between outdoor and indoor units is 90 m or more, the size of the main pipes (both gas side and liquid side) must be increased. Depending on the length of the piping, the capacity may drop, but even in such a case the size of the main pipes has to be increased. More specifications can be found in the technical engineering data book.

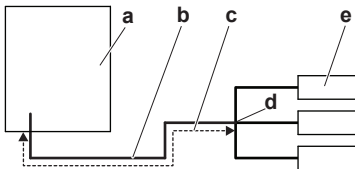

- a Outdoor unit
- b Main pipes
- c Increase if the equivalent piping length is ≥90 m
- d First refrigerant branch kit
- e Indoor unit

Size up		
HP class	Piping outer diameter size (mm)	
	Gas pipe	Liquid pipe
8	19.1 → 22.2	9.5 → 12.7
10	22.2 → 25.4 <sup>(a)</sup>	
12+14	28.6 <sup>(b)</sup>	12.7 → 15.9
16	28.6 → 31.8 <sup>(a)</sup>	
18~22		
24	34.9 <sup>(b)</sup>	19.1 → 22.2
26~34	34.9 → 38.1 <sup>(a)</sup>	
36~54	41.3 <sup>(b)</sup>	

- (a) If the size-up size is NOT available, you must use the standard size. Sizes bigger than the size-up size are NOT allowed. But even if you use the standard size, the equivalent piping length is allowed to be more than 90 m.
- (b) Pipe size-up is NOT allowed.

- The pipe thickness of the refrigerant piping shall comply with the applicable legislation. The minimal pipe thickness for R410A piping must be in accordance with the table below.

Pipe Ø (mm)	Minimal thickness t (mm)
6.4/9.5/12.7	0.80
15.9	0.99
19.1/22.2	0.80
28.6	0.99
34.9	1.21
41.3	1.43

- In case the required pipe sizes (inch sizes) are not available, it is also allowed to use other diameters (mm sizes), taken the following into account:
  - Select the pipe size nearest to the required size.
  - Use the suitable adapters for the change-over from inch to mm pipes (field supply).
  - The additional refrigerant calculation has to be adjusted as mentioned in "5.6.3 To determine the additional refrigerant amount" on page 17.

### F: Piping between refrigerant branch kit and BP unit

Pipe size for direct connection on BP unit must be based on the total capacity of the connected indoor units (only in case RA DX indoor units are connected).

Total capacity index of connected indoor units	Piping outer diameter size (mm)	
	Gas pipe	Liquid pipe
20~62	12.7	6.4
63~149	15.9	9.5
150~208	19.1	

### Example:

Downstream capacity for F=capacity index of unit 4+capacity index of unit 5

### G: Piping between BP unit and RA DX indoor unit

Only in case RA DX indoor units are connected.

Indoor unit capacity index	Piping outer diameter size (mm)	
	Gas pipe	Liquid pipe
20, 25, 30	9.5	6.4
50		
60	15.9	9.5
71		

### 4.2.3 To select refrigerant branch kits



#### INFORMATION

When using FXTQ indoor units, different requirements apply. See "4.2.4 Requirements in case of FXTQ indoor units" on page 9.

#### Refrigerant refnets

For piping example, refer to "4.2.2 To select the piping size" on page 7.

- When using refnet joints at the first branch counted from the outdoor unit side, choose from the following table in accordance with the capacity of the outdoor unit (example: refnet joint a).



Outdoor unit capacity type (HP)	2 pipes
8~10	KHRQ22M29T9
12~22	KHRQ22M64T
24~54	KHRQ22M75T

- For refnet joints other than the first branch (example refnet joint b), select the proper branch kit model based on the total capacity index of all indoor units connected after the refrigerant branch.

Indoor unit capacity index	2 pipes
<200	KHRQ22M20T
200≤x<290	KHRQ22M29T9
290≤x<640	KHRQ22M64T
≥640	KHRQ22M75T

- Concerning refnet headers, choose from the following table in accordance with the total capacity of all the indoor units connected below the refnet header.

Indoor unit capacity index	2 pipes
<200	KHRQ22M29H
200≤x<290	
290≤x<640	KHRQ22M64H <sup>(a)</sup>
≥640	KHRQ22M75H

(a) If the pipe size above the refnet header is Ø34.9 or more, KHRQ22M75H is required.

### **i** INFORMATION

Maximum 8 branches can be connected to a header.

- How to choose an outdoor multi connection piping kit. Choose from the following table in accordance with the number of outdoor units.

Number of outdoor units	Branch kit name
2	BHFQ22P1007
3	BHFQ22P1517

The RYYQ22~54 models, consisting of two or three RYMQ modules, require a 3-pipe system. There is an additional equalising pipe for such modules (in addition to the conventional gas and liquid piping). This equalising pipe does not exist for RYYQ8~20 or RXYQ8~54 units.

The equalising pipe connections for the different RYMQ modules are mentioned in below table.

RYMQ	Equalising pipe Ø (mm)
8	19.1
10~16	22.2
18~20	28.6

Deciding the equalising pipe diameter:

- In case of 3 multi units: the connection diameter of outdoor to T-joint has to be kept.
- In case of 2 multi units: the connection pipe has to have the largest diameter.

There is never a connection of the equalising pipe with the indoor units.

**Example:** (free multi combination)

RYYQ8+RYMQ12+RYMQ18. Largest connection is Ø28.6 (RYMQ18); Ø22.2 (RYMQ12) and Ø19.1 (RYMQ8). In figure below only equalising pipe is shown.

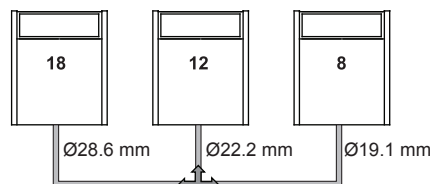

### **i** INFORMATION

Reducers or T-joints are field supplied.

### **!** NOTICE

Refrigerant branch kits can only be used with R410A.

## 4.2.4 Requirements in case of FXTQ indoor units

When using FXTQ indoor units, the following requirements apply.

### Possible combinations

FXTQ indoor units cannot be combined with any other indoor type compatible with the outdoor unit. Only the following outdoor-indoor unit combinations are allowed:

Outdoor unit	FXTQ50	FXTQ63	FXTQ80	FXTQ100
RYYQ8/RXYQ8	4× O	—	—	—
RYYQ10/RXYQ10	—	4× O	—	—
RYYQ12/RXYQ12	—	—	4× O	—
RYYQ14/RXYQ14	—	—	2× O	2× O
RYYQ16/RXYQ16	—	—	—	4× O

### System layout (2 possibilities)

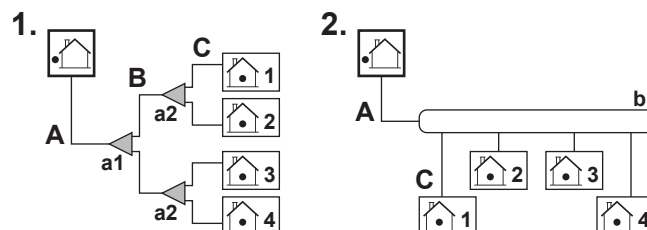

Outdoor Unit	Indoor Unit 1	Indoor Unit 2	Indoor Unit 3	Indoor Unit 4
8 HP	FXTQ50	FXTQ50	FXTQ50	FXTQ50
10 HP	FXTQ63	FXTQ63	FXTQ63	FXTQ63
12 HP	FXTQ80	FXTQ80	FXTQ80	FXTQ80
14 HP	FXTQ100	FXTQ80	FXTQ100	FXTQ80
16 HP	FXTQ100	FXTQ100	FXTQ100	FXTQ100

- A Piping between outdoor unit and first refrigerant branch kit
- B Piping between refrigerant branch kits
- C Piping between refrigerant branch kit and indoor units
- a1, a2 Refnet joints
- b Refnet header

### Refrigerant piping length and height difference

The piping lengths and height differences must comply with the following requirements.

Maximum piping lengths		
1	Longest pipe (actual)	≤120 m
2	After first branch	≤40 m
3	Total piping length	≤300 m
Maximum height differences		
1	Indoor-Outdoor (outdoor lowest)	≤40 m
2	Outdoor-Indoor (outdoor highest)	≤50 m
3	Indoor-Indoor	≤15 m

## 4 Preparation

### A: Piping between outdoor unit and first refrigerant branch kit

Use the following diameters:

Outdoor unit capacity type (HP)	Piping outer diameter size (mm)	
	Gas pipe	Liquid pipe
8	19.1	9.5
10	22.2	9.5
12~16	28.6	12.7

### B: Piping between refrigerant branch kits

Use the following diameters:

Outdoor unit capacity type (HP)	Piping outer diameter size (mm)	
	Gas pipe	Liquid pipe
8+10	22.2	9.5
12	28.6	12.7
14+16	28.6	15.9

### C: Piping between refrigerant branch kit and indoor unit

Use the same diameters as the connections (liquid, gas) on the indoor units. The diameters of the indoor units are as follows:

Indoor unit	Piping outer diameter size (mm)	
	Gas pipe	Liquid pipe
FXTQ50	15.9	9.5
FXTQ63	15.9	9.5
FXTQ80	19.1	9.5
FXTQ100	22.2	9.5

#### a1, a2: Refnet joints

Outdoor unit capacity type (HP)	Refnet joint
8+10	KHRQ22M29T9
12~16	KHRQ22M64T

#### b: Refnet header

Outdoor unit capacity type (HP)	Refnet header
8+10	KHRQ22M64H
12~16	KHRQ22M75H

#### Additional refrigerant charge

When using FXTQ indoor units, additional refrigerant needs to be charged to the system.

Total system refrigerant charge = Z = O+R+P

- O** Standard factory charge of outdoor unit
- R** Additional refrigerant charge according to liquid piping diameter/length and outdoor unit specific amount. See "5.6.3 To determine the additional refrigerant amount" on page 17.
- P** Additional refrigerant charge due to use of FXTQ indoor units.  $P = \sum T_{1,4}$
- T** Additional charge for each indoor unit used (depending on type)

Indoor unit	T (kg)
FXTQ50	0.6
FXTQ63	0.5
FXTQ80	0.9
FXTQ100	1.1

### 4.2.5 Multiple outdoor units: Possible layouts

- The piping between the outdoor units must be routed level or slightly upward to avoid the risk of oil retention into the piping.

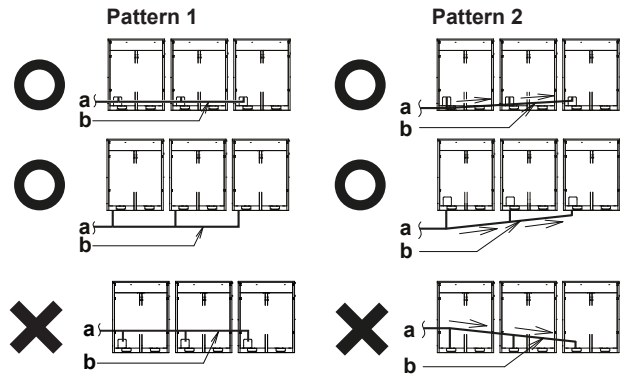

- a** To indoor unit
- b** Piping between outdoor units
- X** Not allowed (oil remains in piping)
- O** Allowed

- To avoid the risk of oil retention to the outmost outdoor unit, always connect the stop valve and the piping between outdoor units as shown in the 4 correct possibilities of the figure below.

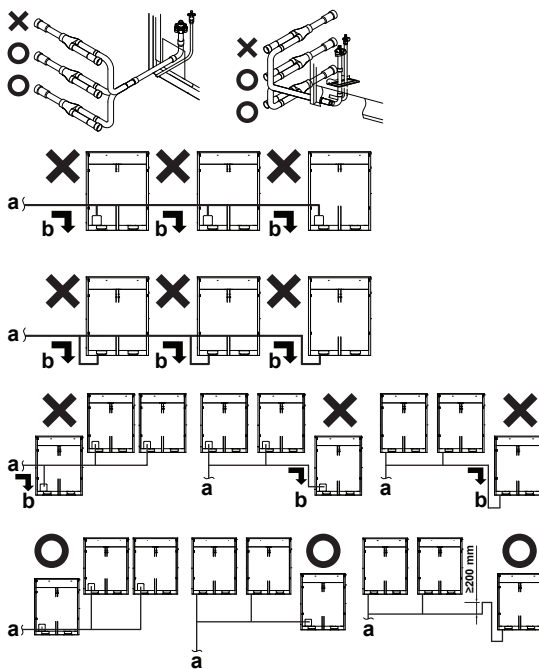

- a** To indoor unit
- b** Oil collects to the outmost outdoor unit when the system stops
- X** Not allowed
- O** Allowed

- If the piping length between the outdoor units exceeds 2 m, create a rise of 200 mm or more in the gas line within a length of 2 m from the kit.

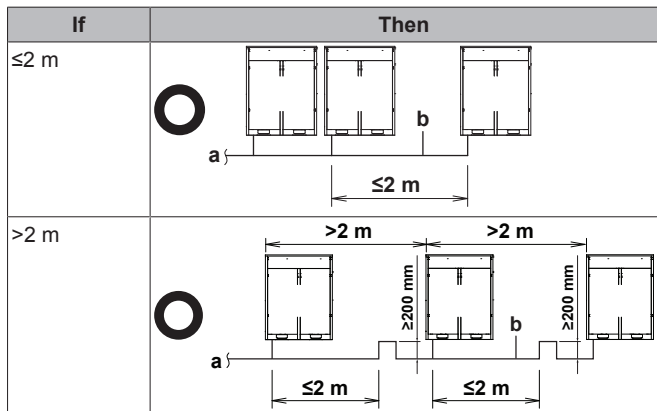

- a** To indoor unit

b Piping between outdoor units



**NOTICE**

There are restrictions on the refrigerant pipe connection order between outdoor units during installation in case of a multiple outdoor unit system. Install according to following restrictions. The capacities of outdoor units A, B and C must fulfill the following restriction conditions:  $A \geq B \geq C$ .

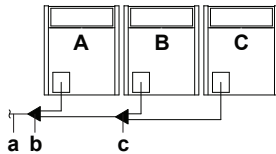

- a To indoor units
- b Outdoor unit multi connecting piping kit (first branch)
- c Outdoor unit multi connecting piping kit (second branch)

### 4.3 Preparing electrical wiring

#### 4.3.1 Safety device requirements

The power supply must be protected with the required safety devices, i.e. a main switch, a slow blow fuse on each phase and an earth leakage protector in accordance with the applicable legislation.

**For standard combinations**

Selection and sizing of the wiring should be done in accordance with the applicable legislation based on the information mentioned in the table below.

Model	Minimum circuit ampacity	Recommended fuses
RYYQ8/RYM8/RXYQ8	16.1 A	20 A
RYYQ10/RYM10/RXYQ10	22.0 A	25 A
RYYQ12/RYM12/RXYQ12	24.0 A	32 A
RYYQ14/RYM14/RXYQ14	27.0 A	32 A
RYYQ16/RYM16/RXYQ16	31.0 A	40 A
RYYQ18/RYM18/RXYQ18	35.0 A	40 A
RYYQ20/RYM20/RXYQ20	39.0 A	50 A

For all models:

- Phase and frequency: 3N~ 50 Hz
- Voltage: 380-415 V
- Transmission line section: 0.75~1.25 mm<sup>2</sup>, maximum length is 1000 m. If the total transmission wiring exceeds these limits, it may result in communication error.

**For non-standard combinations**

Calculate the recommended fuse capacity

Formula	Calculate, by adding the minimum circuit amps of each used unit (according to the table above), multiply the result by 1.1 and select the next higher recommended fuse capacity.
---------	--

Example	Combining the RXYQ30 by using the RXYQ8, RXYQ10, and RXYQ12. <ul style="list-style-type: none"> <li>▪ Minimum circuit ampacity of the RXYQ8=16.1 A</li> <li>▪ Minimum circuit ampacity of the RXYQ10=22.0 A</li> <li>▪ Minimum circuit ampacity of the RXYQ12=24.0 A</li> </ul> Accordingly, the minimum circuit ampacity of the RXYQ30=16.1+22.0+24.0=62.1 A Multiplying the above result by 1.1 (62.1×1.1)=68.31 A, so the recommended fuse capacity would be <b>80 A</b> .
---------	--



**NOTICE**

When using residual current operated circuit breakers, be sure to use a high-speed type 300 mA rated residual operating current.

## 5 Installation

### 5.1 Opening the units

#### 5.1.1 To open the outdoor unit



**DANGER: RISK OF ELECTROCUTION**



**DANGER: RISK OF BURNING**

To gain access to the unit, front plates need to be opened as follows:

**8~12 HP**

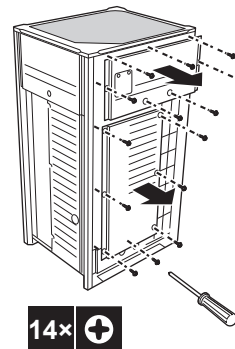

**14~20 HP**

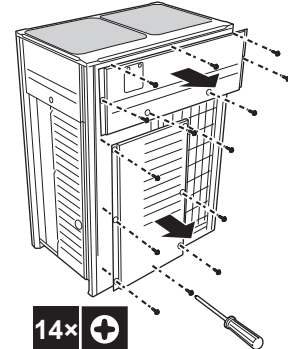

Once the front plates open, the electrical component box can be accessed. See "5.1.2 To open the electrical component box of the outdoor unit" on page 11.

For service purposes, the push buttons on the main PCB need to be accessed. To access these push buttons, the electrical component box cover does not need to be opened. See "6.1.3 To access the field setting components" on page 27.

#### 5.1.2 To open the electrical component box of the outdoor unit



**NOTICE**

Do not apply excessive force when opening the electronic component box cover. Excessive force can deform the cover, resulting in entering of water to cause equipment failure.

## 5 Installation

### 8~12 HP

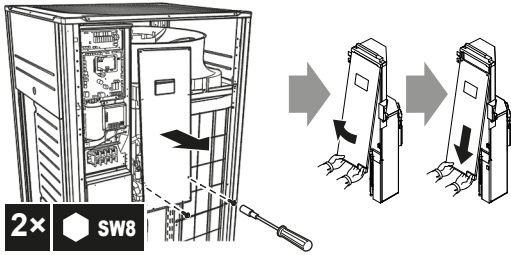

### 14~20 HP

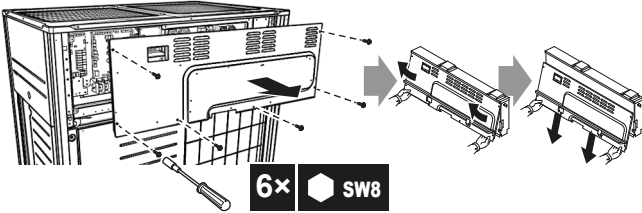

#### NOTICE

When closing the electrical component box cover, make sure that the sealing material on the lower back side of the cover is not caught and bend towards the inside.

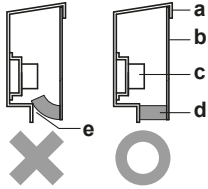

- a Electrical component box cover
- b Front side
- c Power supply terminal block
- d Sealing material
- e Moisture and dirt could enter
- X Not allowed
- O Allowed

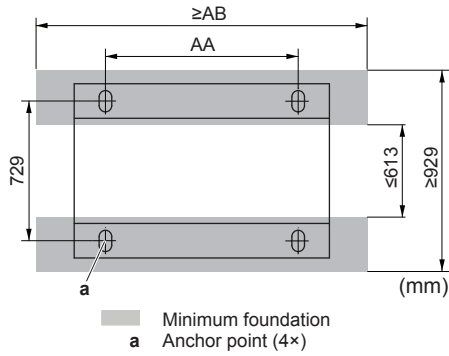

HP	AA	AB
8~12	766	992
14~20	1076	1302

- Fasten the unit in place using four foundation bolts M12. It is best to screw in the foundation bolts until their length remains 20 mm above the foundation surface.

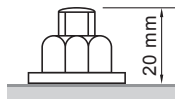

#### NOTICE

- Prepare a water drainage channel around the foundation to drain waste water from around the unit. During heating operation and when the outdoor temperatures are negative, the drained water from the outdoor unit will freeze up. If the water drainage is not taken care of, the area around the unit might be very slippery.
- When installed in a corrosive environment, use a nut with plastic washer (a) to protect the nut tightening part from rust.

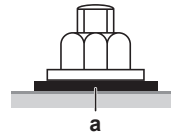

## 5.2 Mounting the outdoor unit

### 5.2.1 To provide the installation structure

Make sure the unit is installed level on a sufficiently strong base to prevent vibration and noise.

#### NOTICE

When the installation height of the unit needs to be increased, do not use stands to only support the corners.

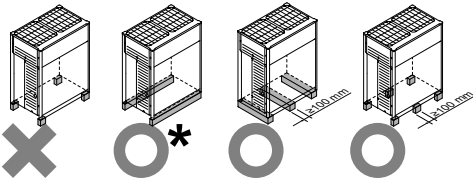

- X Not allowed
- O Allowed (\* = preferred installation)

- The height of the foundation must at least be 150 mm from the floor. In heavy snowfall areas, this height should be increased, depending on the installation place and condition.
- The preferred installation is on a solid longitudinal foundation (steel beam frame or concrete). The foundation must be larger than the grey marked area.

## 5.3 Connecting the refrigerant piping

### 5.3.1 To route the refrigerant piping

Installation of refrigerant piping is possible as front connection or side connection (when taken out from the bottom) as shown in the figure below.

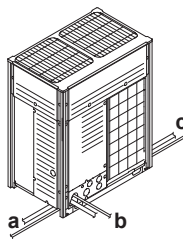

- a Left-side connection
- b Front connection
- c Right-side connection

For side connections, the knockout hole on the bottom plate should be removed:



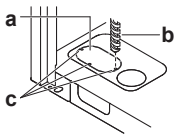

- a Large knockout hole
- b Drill
- c Points for drilling



### NOTICE

Precautions when making knockout holes:

- Avoid damaging the casing.
- After making the knockout holes, we recommend you remove the burrs and paint the edges and areas around the edges using repair paint to prevent rusting.
- When passing electrical wiring through the knockout holes, wrap the wiring with protective tape to prevent damage.

### 5.3.2 To connect the refrigerant piping to the outdoor unit



### NOTICE

- Be sure to use the supplied accessory pipes when carrying out piping work in the field.
- Be sure that the field installed piping does not touch other pipes, the bottom panel or side panel. Especially for the bottom and side connection, be sure to protect the piping with suitable insulation, to prevent it from coming into contact with the casing.

Connection from the stop valves to the field piping can be done by using accessory pipes supplied as accessory.

The connections to the branch kits are the responsibility of the installer (field piping).

### 5.3.3 To connect the multi connection piping kit



### NOTICE

Improper installation may lead to malfunction of the outdoor unit.

- Install the joints horizontally, so that the caution label (a) attached to the joint comes to the top.
  - Do not tilt the joint more than 7.5° (see view A).
  - Do not install the joint vertically (see view B).

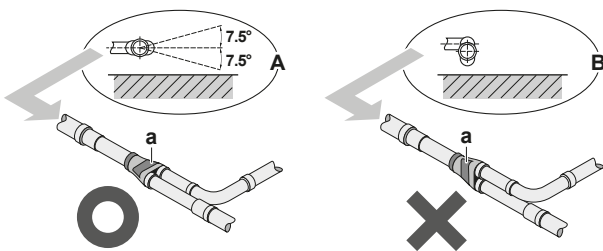

- a Caution label
- X Not allowed
- O Allowed

- Make sure that the total length of the piping connected to the joint is absolute straight for more than 500 mm. Only if a straight field piping of more than 120 mm is connected, more than 500 mm of straight section can be ensured.

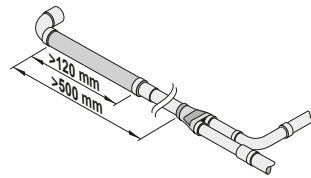

### 5.3.4 Multiple outdoor units: Knockout holes

Connection	Description
Front connection	Remove the front plate knockout holes to connect. <div style="text-align: center;"> </div>
Bottom connection	Remove the knockout holes on the bottom frame and route the piping under the bottom. <div style="text-align: center;"> </div>

### 5.3.5 To protect against contamination

Block all gaps in the holes for passing out piping and wiring using sealing material (field supply) (otherwise the capacity of the unit will drop and small animals may enter the machine).

### 5.3.6 Using the stop valve and service port

#### To handle the stop valve

- Make sure to keep all stop valves open during operation.
- The stop valve is factory closed.

#### To open the stop valve

- 1 Remove the stop valve cover.
- 2 Insert a hexagon wrench into the stop valve and turn the stop valve counterclockwise.
- 3 When the stop valve cannot be turned any further, stop turning.

**Result:** The valve is now open.

To fully open the  $\varnothing 19.1 \text{ mm} \sim \varnothing 25.4 \text{ mm}$  stop valve, turn the hexagonal wrench until a torque between 27 and 33 N·m is achieved.

Inadequate torque may cause leakage of refrigerant and breakage of the stop valve cap.

## 5 Installation

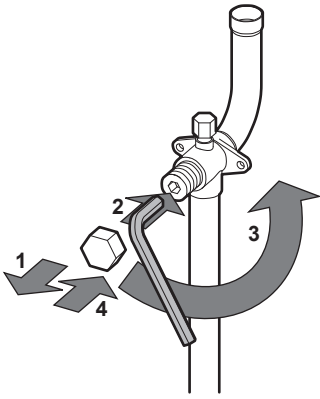

### NOTICE

Pay attention that mentioned torque range is applicable for opening  $\varnothing 19.1\sim\varnothing 25.4$  mm stop valves only.

### To close the stop valve

- 1 Remove the stop valve cover.
- 2 Insert a hexagon wrench into the stop valve and turn the stop valve clockwise.
- 3 When the stop valve cannot be turned any further, stop turning.

**Result:** The valve is now closed.

Closing direction:

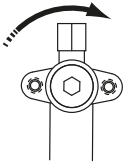

### To handle the stop valve cover

- The stop valve cover is sealed where indicated by the arrow. Take care not to damage it.
- After handling the stop valve, make sure to tighten the stop valve cover securely. For the tightening torque, refer to the table below.
- Check for refrigerant leaks after tightening the stop valve cover.

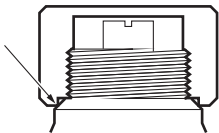

### To handle the service port

- Always use a charge hose equipped with a valve depressor pin, since the service port is a Schrader type valve.
- After handling the service port, make sure to tighten the service port cover securely. For the tightening torque, refer to the table below.
- Check for refrigerant leaks after tightening the service port cover.

## Tightening torques

Stop valve size (mm)	Tightening torque N•m (turn clockwise to close)			
	Shaft			
	Valve body	Hexagonal wrench	Cap (valve lid)	Service port
$\varnothing 9.5$	5.4~6.6	4 mm	13.5~16.5	11.5~13.9
$\varnothing 12.7$	8.1~9.9		18.0~22.0	
$\varnothing 15.9$	13.5~16.5	6 mm	23.0~27.0	
$\varnothing 19.1$	27.0~33.0		22.5~27.5	
$\varnothing 25.4$		8 mm		

### 5.3.7 To remove the pinched pipes

#### WARNING

Any gas or oil remaining inside the stop valve may blow off the pinched piping.

Failure to observe the instructions in procedure below properly may result in property damage or personal injury, which may be serious depending on the circumstances.

Use the following procedure to remove the pinched piping:

- 1 Remove the valve cover and make sure that the stop valves are fully closed.

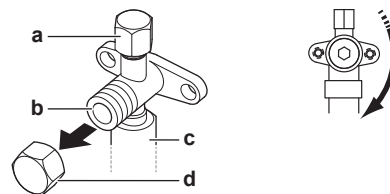

- a Service port and service port cover
- b Stop valve
- c Field piping connection
- d Stop valve cover

- 2 Connect the vacuuming/recovery unit through a manifold to the service port of all stop valves.

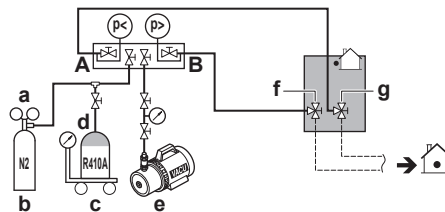

- a Pressure reducing valve
- b Nitrogen
- c Weighing scales
- d Refrigerant R410A tank (siphon system)
- e Vacuum pump
- f Liquid line stop valve
- g Gas line stop valve
- A Valve A
- B Valve B

- 3 Recover gas and oil from the pinched piping by using a recovery unit.

#### CAUTION

Do not vent gases into the atmosphere.

- 4 When all gas and oil is recovered from the pinched piping, disconnect the charge hose and close the service ports.
- 5 Cut off the lower part of the gas, liquid and equalising stop valve pipes along the black line. Use an appropriate tool (e.g. a pipe cutter, a pair of nippers).

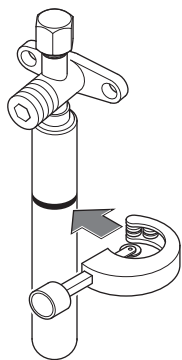

**WARNING**

Never remove the pinched piping by brazing.  
Any gas or oil remaining inside the stop valve may blow off the pinched piping.

6 Wait until all oil is dripped out before continuing with the connection of the field piping in case the recovery was not complete.

## 5.4 Checking the refrigerant piping

### 5.4.1 About checking the refrigerant piping

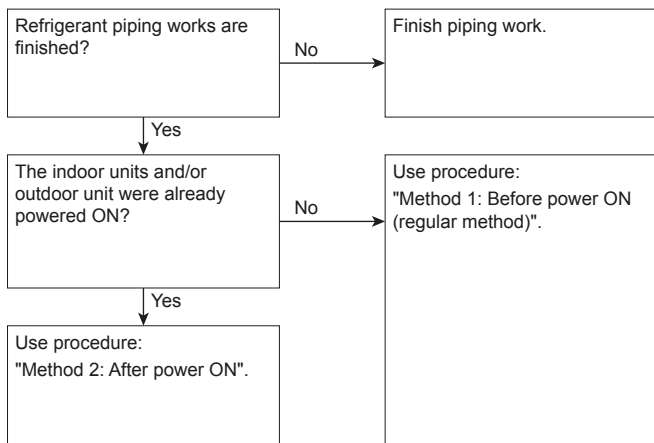

It is very important that all refrigerant piping work is done before the units (outdoor or indoor) are powered on.

When the units are powered on, the expansion valves will initialise. This means that they will close. Leak test and vacuum drying of field piping and indoor units is impossible when this happens.

Therefore, there will be explained 2 methods for initial installation, leak test and vacuum drying.

#### Method 1: Before power ON

If the system has not yet been powered on, no special action is required to perform the leak test and the vacuum drying.

#### Method 2: After power ON

If the system has already been powered on, activate setting [2-21] (refer to "6.1.4 To access mode 1 or 2" on page 27). This setting will open field expansion valves to guarantee a R410A piping pathway and make it possible to perform the leak test and the vacuum drying.

**NOTICE**  
Make sure that all indoor units connected to the outdoor unit are powered on.

**NOTICE**  
Wait until the outdoor unit has finished the initialisation to apply setting [2-21].

### Leak test and vacuum drying

Checking the refrigerant piping involves:

- Checking for any leakages in the refrigerant piping.
- Performing vacuum drying to remove all moisture, air or nitrogen in the refrigerant piping.

If there is a possibility of moisture being present in the refrigerant piping (for example, water may have entered the piping), first carry out the vacuum drying procedure below until all moisture has been removed.

All piping inside the unit has been factory tested for leaks.

Only field installed refrigerant piping needs to be checked. Therefore, make sure that all the outdoor unit stop valves are firmly closed before performing leak test or vacuum drying.

**NOTICE**  
Make sure that all (field supplied) field piping valves are OPEN (not outdoor unit stop valves!) before you start leak test and vacuuming.

For more information on the state of the valves, refer to "5.4.3 Checking refrigerant piping: Setup" on page 15.

### 5.4.2 Checking refrigerant piping: General guidelines

Connect the vacuum pump through a manifold to the service port of all stop valves to increase efficiency (refer to "5.4.3 Checking refrigerant piping: Setup" on page 15).

**NOTICE**  
Use a 2-stage vacuum pump with a non-return valve or a solenoid valve that can evacuate to a gauge pressure of -100.7 kPa (-1.007 bar)(5 Torr absolute).

**NOTICE**  
Make sure the pump oil does not flow oppositely into the system while the pump is not working.

**NOTICE**  
Do not purge the air with refrigerants. Use a vacuum pump to evacuate the installation.

### 5.4.3 Checking refrigerant piping: Setup

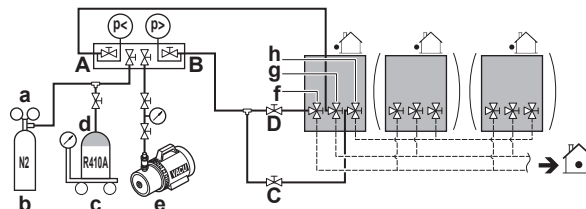

- a Pressure reducing valve
- b Nitrogen
- c Weighing scales
- d Refrigerant R410A tank (siphon system)
- e Vacuum pump
- f Liquid line stop valve
- g Gas line stop valve
- h Equalising line stop valve (only for RYMQ)
- A Valve A
- B Valve B

## 5 Installation

C Valve C  
D Valve D

Valve	State of valve
Valve A	Open
Valve B	Open
Valve C	Open
Valve D	Open
Liquid line stop valve	Close
Gas line stop valve	Close
Equalising line stop valve	Close

### NOTICE

The connections to the indoor units and all indoor units should also be leak and vacuum tested. Keep any possible (field supplied) field piping valves open as well.

Refer to the indoor unit installation manual for more details. Leak test and vacuum drying should be done before the power supply is set to the unit. If not, see also the flow chart earlier described in this chapter (see "5.4.1 About checking the refrigerant piping" on page 15).

### 5.4.4 To perform a leak test

The leak test must satisfy the specifications of EN378-2.

#### To check for leaks: Vacuum leak test

- 1 Evacuate the system from the liquid and gas piping to  $-100.7 \text{ kPa}$  ( $-1.007 \text{ bar}$ ) (5 Torr absolute) for more than 2 hours.
- 2 Once reached, turn off the vacuum pump and check that the pressure does not rise for at least 1 minute.
- 3 Should the pressure rise, the system may either contain moisture (see vacuum drying below) or have leaks.

#### To check for leaks: Pressure leak test

- 1 Break the vacuum by pressurising with nitrogen gas to a minimum gauge pressure of  $0.2 \text{ MPa}$  (2 bar). Never set the gauge pressure higher than the maximum operation pressure of the unit, i.e.  $4.0 \text{ MPa}$  (40 bar).
- 2 Test for leaks by applying a bubble test solution to all piping connections.
- 3 Discharge all nitrogen gas.

### NOTICE

Make sure to use a recommended bubble test solution from your wholesaler. Do not use soap water, which may cause cracking of flare nuts (soap water may contain salt, which absorbs moisture that will freeze when the piping gets cold), and/or lead to corrosion of flared joints (soap water may contain ammonia which causes a corrosive effect between the brass flare nut and the copper flare).

### 5.4.5 To perform vacuum drying

To remove all moisture from the system, proceed as follows:

- 1 Evacuate the system for at least 2 hours to a target vacuum of  $-100.7 \text{ kPa}$  ( $-1.007 \text{ bar}$ ) (5 Torr absolute).
- 2 Check that, with the vacuum pump turned off, the target vacuum is maintained for at least 1 hour.
- 3 Should you fail to reach the target vacuum within 2 hours or maintain the vacuum for 1 hour, the system may contain too much moisture. In that case, break the vacuum by pressurising with nitrogen gas to a gauge pressure of  $0.05 \text{ MPa}$  (0.5 bar) and repeat steps 1 to 3 until all moisture has been removed.

- 4 Depending on whether you want to immediately charge refrigerant through the refrigerant charge port or first pre-charge a portion of refrigerant through the liquid line, either open the outdoor unit stop valves, or keep them closed. See "5.6.2 About charging refrigerant" on page 17 for more information.

## 5.5 To insulate the refrigerant piping

After finishing the leak test and vacuum drying, the piping must be insulated. Take into account the following points:

- Make sure to insulate the connection piping and refrigerant branch kits entirely.
- Be sure to insulate the liquid and gas piping (for all units).
- Use heat resistant polyethylene foam which can withstand a temperature of  $70^\circ\text{C}$  for liquid piping and polyethylene foam which can withstand a temperature of  $120^\circ\text{C}$  for gas piping.
- Reinforce the insulation on the refrigerant piping according to the installation environment.

Ambient temperature	Humidity	Minimum thickness
$\leq 30^\circ\text{C}$	75% to 80% RH	15 mm
$> 30^\circ\text{C}$	$\geq 80\%$ RH	20 mm

Condensation might form on the surface of the insulation.

- If there is a possibility that condensation on the stop valve might drip down into the indoor unit through gaps in the insulation and piping because the outdoor unit is located higher than the indoor unit, this must be prevented by sealing up the connections. See below figure.

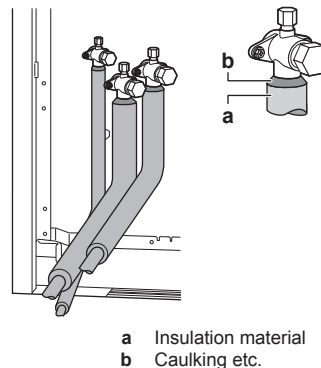

## 5.6 Charging refrigerant

### 5.6.1 Precautions when charging refrigerant



#### WARNING

- Only use R410A as refrigerant. Other substances may cause explosions and accidents.
- R410A contains fluorinated greenhouse gases. Its global warming potential (GWP) value is 2087.5. Do NOT vent these gases into the atmosphere.
- When charging refrigerant, always use protective gloves and safety glasses.



#### NOTICE

If the power of some units is turned off, the charging procedure cannot be finished properly.



#### NOTICE

In case of a multiple outdoor system, turn on the power of all outdoor units.



**NOTICE**

Be sure to turn on the power 6 hours before operation in order to have power running to the crankcase heater and to protect the compressor.

**NOTICE**

If operation is performed within 12 minutes after the indoor and outdoor units are turned on, the compressor will not operate before the communication is established in a correct way between outdoor unit(s) and indoor units.

**NOTICE**

Before starting charging procedures, check if the 7-segment display indication of the outdoor unit A1P PCB is as normal (see "6.1.4 To access mode 1 or 2" on page 27). If a malfunction code is present, see "8.1 Solving problems based on error codes" on page 32.

**NOTICE**

Make sure all connected indoor units are recognised (see [1-10], [1-38] and [1-39] in "6.1.7 Mode 1: Monitoring settings" on page 28).

**NOTICE**

Close the front panel before any refrigerant charge operation is executed. Without the front panel attached the unit cannot judge correctly whether it is operating properly or not.

**NOTICE**

In case of maintenance and the system (outdoor unit+field piping+indoor units) does not contain any refrigerant any more (e.g., after refrigerant reclaim operation), the unit has to be charged with its original amount of refrigerant (refer to the nameplate on the unit) by pre-charging before the automatic charging function can be started.

## 5.6.2 About charging refrigerant

Once vacuum drying is finished, additional refrigerant charging can start.

There are two methods to charge additional refrigerant.

Method	See
Automatic charge	"5.6.6 Step 6a: To automatically charge refrigerant" on page 22
Manual charge	"5.6.7 Step 6b: To manually charge refrigerant" on page 23

**INFORMATION**

Adding refrigerant using the automatic refrigerant charging function is not possible when Hydrobox units or RA DX indoor units are connected to the system.

To speed up the refrigerant charging process, it is in case of larger systems recommended to first pre-charge a portion of refrigerant through the liquid line before proceeding with the actual automatic or manual charging. This step is included in below procedure (see "5.6.5 To charge refrigerant" on page 21). It can be skipped, but charging will take longer then.

A flow chart is available which gives an overview of the possibilities and actions to be taken (see "5.6.4 To charge refrigerant: Flow chart" on page 19).

## 5.6.3 To determine the additional refrigerant amount

**INFORMATION**

When using FXTQ indoor units, different requirements apply. See "4.2.4 Requirements in case of FXTQ indoor units" on page 9.

**INFORMATION**

For final charge adjustment in the test laboratory, please contact your local dealer.

**NOTICE**

The refrigerant charge of the system must be less than 100 kg. This means that in case the calculated total refrigerant charge is equal to or more than 95 kg you must divide your multiple outdoor system into smaller independent systems, each containing less than 95 kg refrigerant charge. For factory charge, refer to the unit name plate.

**Formula:**

$$R = [(X_1 \times \text{Ø}22.2) \times 0.37 + (X_2 \times \text{Ø}19.1) \times 0.26 + (X_3 \times \text{Ø}15.9) \times 0.18 + (X_4 \times \text{Ø}12.7) \times 0.12 + (X_5 \times \text{Ø}9.5) \times 0.059 + (X_6 \times \text{Ø}6.4) \times 0.022] + A + B + C$$

R Additional refrigerant to be charged [in kg and rounded off to 1 decimal place]

$X_{1...6}$  Total length [m] of liquid piping size at Øa

A~C Parameters A~C

**Parameter A.** In case of a multi-outdoor-unit system, add the sum of the individual outdoor unit charge factors.

Piping length <sup>(a)</sup>	CR	A		
		8 HP	10~16 HP	18~20 HP
≤30 m	50%≤CR≤105%	0 kg		0.5 kg
	105%<CR≤130%	0.5 kg		1 kg
>30 m	50%≤CR≤70%	0 kg		0.5 kg
	70%<CR≤85%	0.3 kg	0.5 kg	1.0 kg
	85%<CR≤105%	0.7 kg	1 kg	1.5 kg
	105%<CR≤130%	1.2 kg	1.5 kg	2.0 kg

(a) Piping length is considered the distance from the outdoor unit to the farthest indoor unit

CR Total indoor unit capacity connection ratio

**Parameter B.** This is ONLY required for RYYQ8~20 models, NOT for RXYQ8~54 and RYYQ22~54.

Model	CR≥100%				CR<100%
	If	Then	If	Then	
RYYQ8	N≥4	B=2 kg	N<4	B=0.9 kg	B=0.9 kg
RYYQ10	N≥5		N<5		
RYYQ12	N≥6	B=2.2 kg	N<6	B=1.1 kg	B=1.1 kg
RYYQ14	N≥7		N<7		
RYYQ16	N≥8	B=2.4 kg	N<8	B=1.3 kg	B=1.3 kg
RYYQ18	N≥9		N<9		
RYYQ20	N≥10		N<10		

CR Total indoor unit capacity connection ratio

N Number of VRV DX and RA DX indoor units connected to the outdoor unit

**Parameter C.** In case of a multi-outdoor-unit system, add the sum of the individual outdoor unit charge factors.

## 5 Installation

Model	CR $\geq$ 100%				CR<100%
	If	Then	If	Then	
8 HP	N $\geq$ 4	C=N $\times$ 0.1 kg	N<4	C=0 kg	C=0 kg
10 HP	N $\geq$ 5		N<5		
12 HP	N $\geq$ 6		N<6		
14 HP	N $\geq$ 7		N<7		
16 HP	N $\geq$ 8		N<8		
18 HP	N $\geq$ 9		N<9		
20 HP	N $\geq$ 10		N<10		

CR Total indoor unit capacity connection ratio  
 N Number of VRV DX and RA DX indoor units connected to the outdoor unit

Parameter C – Example with multiple outdoor units:

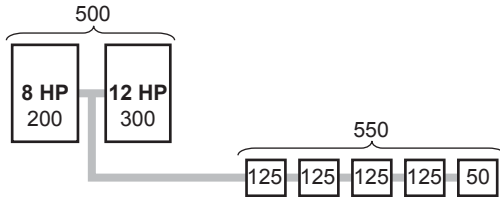

#	Action
1	Determine the connection ratio: <ul style="list-style-type: none"> <li>Total outdoor unit capacity class = 500</li> <li>Total indoor unit capacity class = 550</li> </ul> => CR $\geq$ 100%
2	Determine parameter C: <ul style="list-style-type: none"> <li>N=5</li> <li>8 HP: N<math>\geq</math>4 =&gt; C1=N<math>\times</math>0.1=5<math>\times</math>0.1 kg</li> <li>12 HP: N&lt;6 =&gt; C2=0 kg</li> </ul> => C=C1+C2=0.5 kg

**Metric piping.** When using metric piping, replace the weight factors in the formula by the ones from the following table:

Inch piping		Metric piping	
Piping	Weight factor	Piping	Weight factor
Ø6.4 mm	0.022	Ø6 mm	0.018
Ø9.5 mm	0.059	Ø10 mm	0.065
Ø12.7 mm	0.12	Ø12 mm	0.097
Ø15.9 mm	0.18	Ø15 mm	0.16
		Ø16 mm	0.18
Ø19.1 mm	0.26	Ø18 mm	0.24
Ø22.2 mm	0.37	Ø22 mm	0.35

5.6.4 To charge refrigerant: Flow chart

For more information, see "5.6.5 To charge refrigerant" on page 21.

Pre-charging refrigerant

**Step 1**  
Calculate additional refrigerant charge amount: R (kg)

**Step 2+3**

- Open valves C, D and B to the liquid and equalising line
- Charge the equalising line to maximally 0.05 MPa, then close valve C and disconnect its connection to the manifold. Continue pre-charging through the liquid line only
- Execute pre-charging amount: Q (kg)

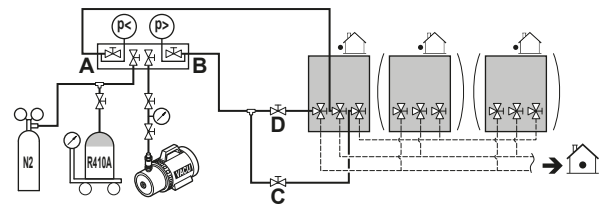

**Step 4a**

- Close valves D and B
- Charging is finished
- Fill in the amount on the additional refrigerant charge label
- Input the additional refrigerant amount via setting [2-14]
- Go to test run

Refrigerant overcharge happened, recover refrigerant to reach R=Q

**Step 4b**  
Close valves D and B

Continued on next page >>

## 5 Installation

### Charging refrigerant

<< Continuation of previous page

R>Q

#### Step 5

- Connect valve A to the refrigerant charge port (d)
- Open all outdoor unit stop valves

#### Step 6

Proceed with automatic or manual charge

#### Automatic charge

##### Step 6a

- Push 1x BS2: "888"
- Push BS2 for more than 5 seconds "t0 !" pressure equalisation

Depending on ambient conditions, the unit will decide to perform autocharge operation in heating or cooling mode.

Continued on next page >>

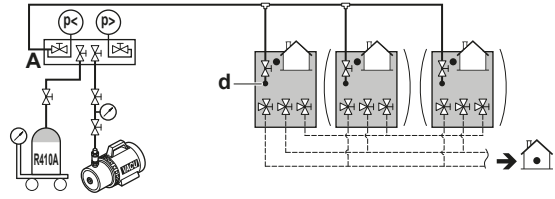

#### Manual charge

##### Step 6b

Activate field setting [2-20]=1  
Unit will start manual refrigerant charging operation.

- Open valve A
- Charge remaining amount of refrigerant P (kg)  
 $R=Q+P$

- Close valve A
- Push BS3 to stop manual charging
- Charging is finished
- Fill in the amount on the additional refrigerant charge label
- Input the additional refrigerant amount via setting [2-14]
- Go to test run



<< Continuation of previous page

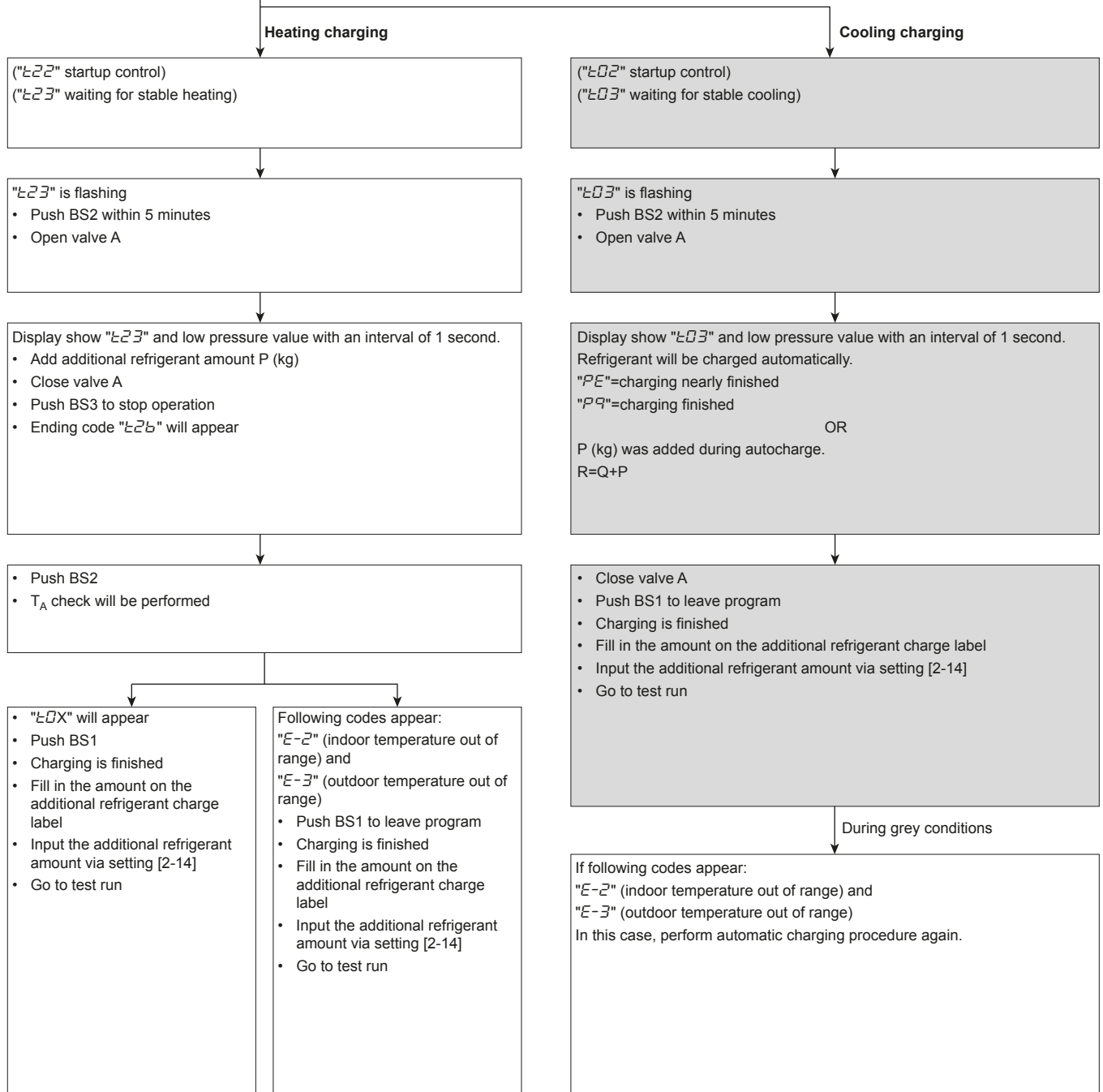

### 5.6.5 To charge refrigerant

Follow the steps as described below and take into account whether you want to use the automatic charge function or not.

#### Pre-charging refrigerant

- 1 Calculate the additional amount of refrigerant to be added using the formula mentioned in "5.6.3 To determine the additional refrigerant amount" on page 17.
- 2 The first 10 kg of additional refrigerant can be pre-charged without outdoor unit operation.

If	Then
The additional refrigerant amount is smaller than 10 kg	Perform steps 3~4.
The additional refrigerant charge is larger than 10 kg	Perform steps 3~6.

- 3 Pre-charging can be done without compressor operation, by connecting the refrigerant bottle to the service ports of the liquid and equalising stop valves (open valve B). Make sure that valve A and all outdoor unit stop valves are closed.



#### NOTICE

During pre-charging, the refrigerant is charged through the liquid line. Close valve A and disconnect the manifold from the gas line. The equalising line is ONLY charged to break the vacuum. Charge it to maximally 0.05 MPa (0.5 bar), then close valve C and disconnect its connection to the manifold. Continue pre-charging through the liquid line only.

## 5 Installation

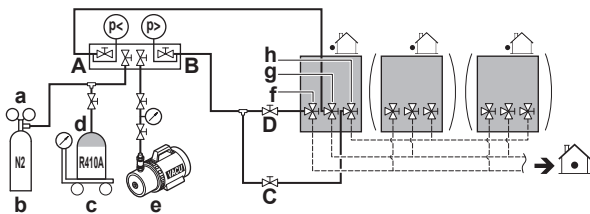

- a Pressure reducing valve
- b Nitrogen
- c Weighing scales
- d Refrigerant R410A tank (siphon system)
- e Vacuum pump
- f Liquid line stop valve
- g Gas line stop valve
- h Equalising line stop valve (only for RYMQ)
- A Valve A
- B Valve B
- C Valve C
- D Valve D

4 Do one of the following:

	If	Then
4a	The calculated additional refrigerant amount is reached by above pre-charging procedure	Close valves D and B and disconnect the manifold connection to the liquid line.
4b	The total amount of refrigerant could not be charged by pre-charging	Close valves D and B, disconnect the manifold connection to the liquid line, and perform steps 5-6.

### **i** INFORMATION

If the total additional refrigerant amount was reached in step 4 (by pre-charging only), record the amount of refrigerant that was added on the additional refrigerant charge label provided with the unit and attach it on the back side of the front panel.

Additionally, input the additional refrigerant amount into the system via setting [2-14].

Perform the test procedure as described in "7 Commissioning" on page 30.

### Charging refrigerant

5 After pre-charging, connect valve A to the refrigerant charge port and charge the remaining additional refrigerant through this port. Open all outdoor unit stop valves. At this point, valve A must remain closed!

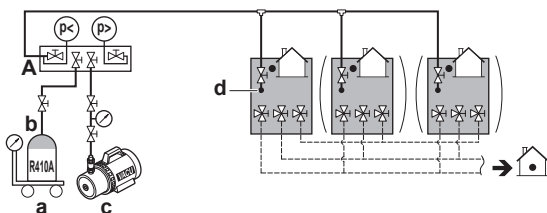

- a Weighing scales
- b Refrigerant R410A tank (siphon system)
- c Vacuum pump
- d Refrigerant charge port
- A Valve A

### **i** INFORMATION

For a multi outdoor unit system, it is not required to connect all charge ports to a refrigerant tank.

The refrigerant will be charged with  $\pm 22$  kg in 1 hour time at an outdoor temperature of 30°C DB or with  $\pm 6$  kg at an outdoor temperature of 0°C DB.

If you need to speed up in case of a multiple outdoor system, connect the refrigerant tanks to each outdoor unit.

### **!** NOTICE

- The refrigerant charging port is connected to the piping inside the unit. The unit's internal piping is already factory charged with refrigerant, so be careful when connecting the charge hose.
- After adding the refrigerant, do not forget to close the lid of the refrigerant charging port. The tightening torque for the lid is 11.5 to 13.9 N·m.
- In order to ensure uniform refrigerant distribution, it may take the compressor  $\pm 10$  minutes to start up after the unit has started operation. This is not a malfunction.

6 Proceed with one of the following:

6a	<a href="#">"5.6.6 Step 6a: To automatically charge refrigerant" on page 22</a>
6b	<a href="#">"5.6.7 Step 6b: To manually charge refrigerant" on page 23</a>

### **i** INFORMATION

After charging refrigerant:

- Record the additional refrigerant amount on the refrigerant label provided with the unit and attach it to the backside of the front panel.
- Input the additional refrigerant amount into the system via setting [2-14].
- Perform the test procedure described in "7 Commissioning" on page 30.

### 5.6.6 Step 6a: To automatically charge refrigerant

#### **i** INFORMATION

The automatic refrigerant charging has limits as described below. Out of these limits, the system cannot operate the automatic refrigerant charging:

- Outdoor temperature: 0~43°C DB.
- Indoor temperature: 10~32°C DB.
- Total indoor unit capacity:  $\geq 80\%$ .

When "E23" or "E03" starts flashing (ready for charging), push BS2 within 5 minutes. Open valve A. If BS2 is not pushed within 5 minutes, a malfunction code will appear:

If	Then
Heating operation	"E23" will be flashing. Push BS2 to restart the procedure.
Cooling operation	Malfunction code "P2" will appear. Push BS1 to abort and restart the procedure.

Test run including detailed refrigerant status check is required to use the leak detection functionality. More information, see "7 Commissioning" on page 30.

If	Then
"E01", "E02", or "E03" appears	Push BS1 to finish the automatic charging function procedure. The ambient conditions are favourable to execute the test run.
"E-2", or "E-3" appears	The ambient conditions are NOT favourable to execute the test run. Push BS1 to finish the automatic charging procedure.

#### **i** INFORMATION

In case a malfunction code occurred during this automatic charging procedure, the unit will stop and indicate "E23" flashing. Push BS2 to restart the procedure.

**i** INFORMATION

- When a malfunction is detected during the procedure (e.g., in case of closed stop valve), a malfunction code will be displayed. In that case, refer to ["8.1 Solving problems based on error codes" on page 32](#) and solve the malfunction accordingly. Resetting the malfunction can be done by pushing BS1. The procedure can be restarted from ["5.6.6 Step 6a: To automatically charge refrigerant" on page 22](#).
- Aborting the automatic refrigerant charge is possible by pushing BS1. The unit will stop and return to idle condition.

**5.6.7 Step 6b: To manually charge refrigerant****i** INFORMATION

The manual refrigerant charge operation will automatically stop within 30 minutes. If charging is not completed after 30 minutes, perform the additional refrigerant charging operation again.

**i** INFORMATION

- When a malfunction is detected during the procedure (e.g., in case of closed stop valve), a malfunction code will be displayed. In that case, refer to ["5.6.8 Error codes when charging refrigerant" on page 23](#) and solve the malfunction accordingly. Resetting the malfunction can be done by pushing BS3. The procedure can be restarted from ["5.6.7 Step 6b: To manually charge refrigerant" on page 22](#).
- Aborting the manual refrigerant charge is possible by pushing BS3. The unit will stop and return to idle condition.

**5.6.8 Error codes when charging refrigerant**

Code	Cause	Solution
P2	Unusual low pressure on suction line	Close valve A immediately. Push BS3 to reset. Check following items before retrying autocharge procedure: <ul style="list-style-type: none"> <li>Check if the gas side stop valve is opened correctly.</li> <li>Check if the valve of the refrigerant cylinder is opened.</li> <li>Check if the air inlet and outlet of the indoor unit are not obstructed.</li> </ul>
P8	Freeze-up prevention indoor unit	Close valve A immediately. Push BS3 to reset. Retry autocharge procedure.
E-2	Indoor unit is out of temperature range for leak detection operation	Retry when ambient conditions are satisfied.
E-3	Outdoor unit is out of temperature range for leak detection operation	Retry when ambient conditions are satisfied.

Code	Cause	Solution
E-5	Indicates an indoor unit which is not compatible with leak detection functionality is installed (e.g., RA DX indoor unit, Hydrobox, ...)	Refer to requirements to be able to execute leak detection operation.
Other malfunction code	—	Close valve A immediately. Confirm the malfunction code and take corresponding action, <a href="#">"8.1 Solving problems based on error codes" on page 32</a> .

**5.6.9 Checks after charging refrigerant**

- Are all stop valves open?
- Is the amount of refrigerant, that has been added, recorded on the refrigerant charge label?

**NOTICE**

Make sure to open all stop valves after (pre-) charging the refrigerant.

Operating with the stop valves closed will damage the compressor.

**5.6.10 To fix the fluorinated greenhouse gases label**

- Fill in the label as follows:

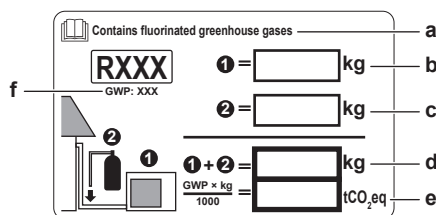

- If a multilingual fluorinated greenhouse gases label is delivered with the unit (see accessories), peel off the applicable language and stick it on top of **a**.
- Factory refrigerant charge: see unit name plate
- Additional refrigerant amount charged
- Total refrigerant charge
- Greenhouse gas emissions** of the total refrigerant charge expressed as tonnes CO<sub>2</sub>-equivalent
- GWP = Global warming potential

**NOTICE**

In Europe, the **greenhouse gas emissions** of the total refrigerant charge in the system (expressed as tonnes CO<sub>2</sub>-equivalent) is used to determine the maintenance intervals. Follow the applicable legislation.

**Formula to calculate the greenhouse gas emissions:**  
 $\text{GWP value of the refrigerant} \times \text{Total refrigerant charge [in kg]} / 1000$

- Fix the label on the inside of the outdoor unit near the gas and liquid stop valves.

**5.7 Connecting the electrical wiring****5.7.1 Field wiring: Overview**

Field wiring consists of power supply (always including earth) and indoor-outdoor communication (= transmission) wiring.

**Example:**

## 5 Installation

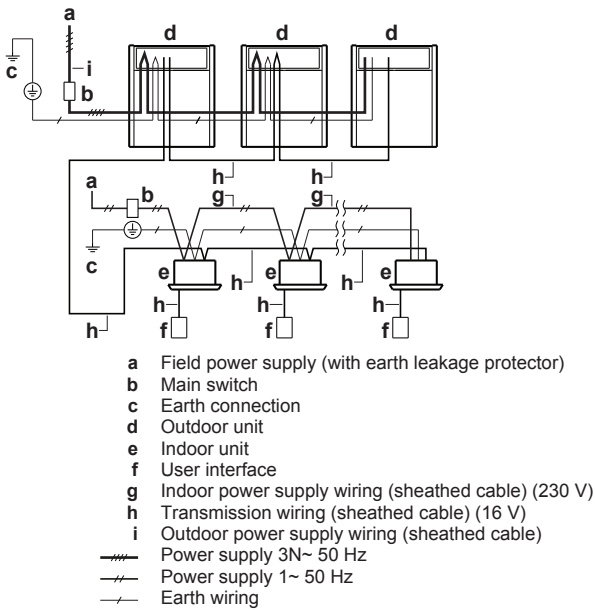

### 5.7.2 Guidelines when knocking out knockout holes

- To punch a knockout hole, hit on it with a hammer.
- After knocking out the holes, we recommend removing any burrs and paint the edges and areas around the holes using repair paint to prevent rusting.
- When passing electrical wiring through the knockout holes, prevent damage to the wires by wrapping the wiring with protective tape, putting the wires through field supplied protective wire conduits at that location, or install suitable field supplied wire nipples or rubber bushings into the knockout holes.

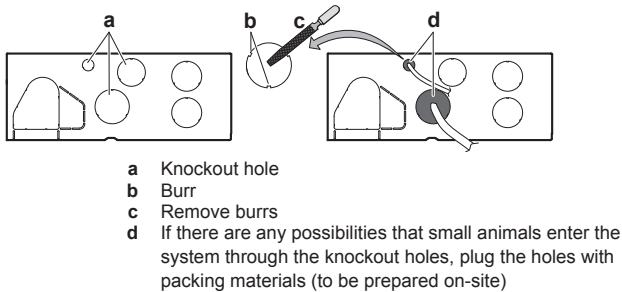

### 5.7.3 To route and fix the transmission wiring

Transmission wiring can be routed through the front side only. Fix it to the upper mounting hole.

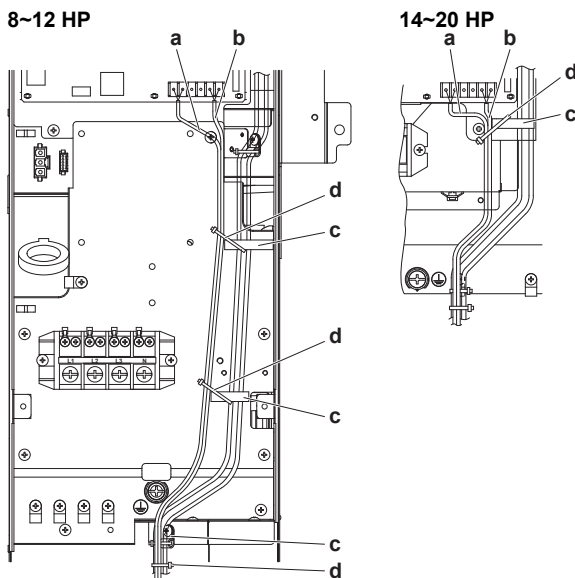
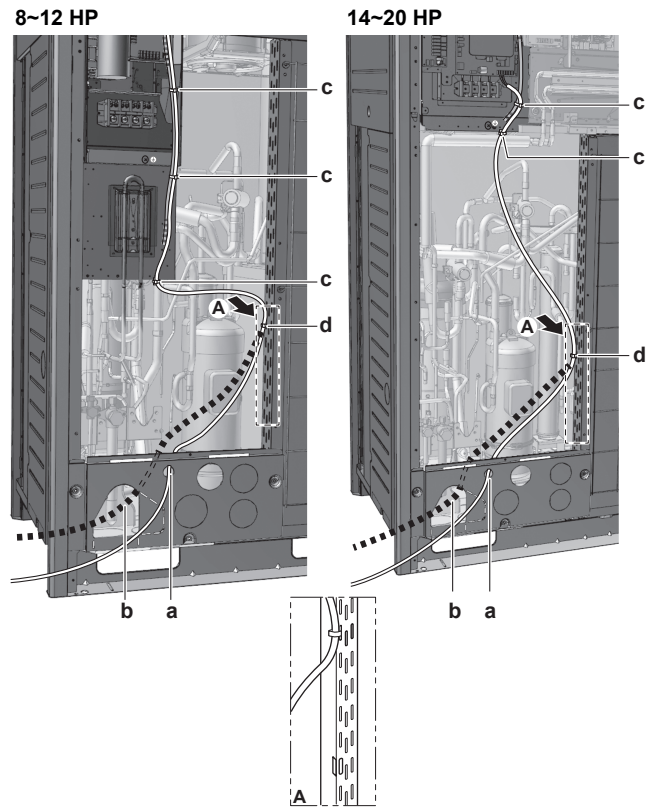

Fix to the indicated plastic brackets using field supplied clamping material.

### 5.7.4 To connect the transmission wiring

The wiring from the indoor units must be connected to the F1/F2 (In-Out) terminals on the PCB in the outdoor unit.

Tightening torque of the transmission wiring terminals:

Screw size	Tightening torque (N·m)
M3.5 (A1P)	0.80~0.96

### In case of single outdoor unit installation

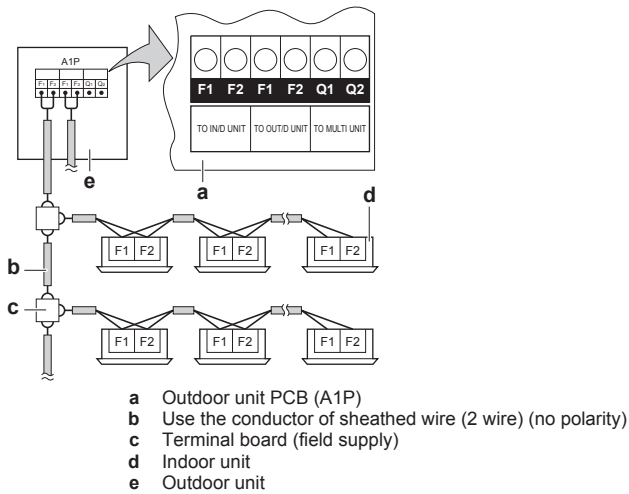

### In case of multi outdoor unit installation

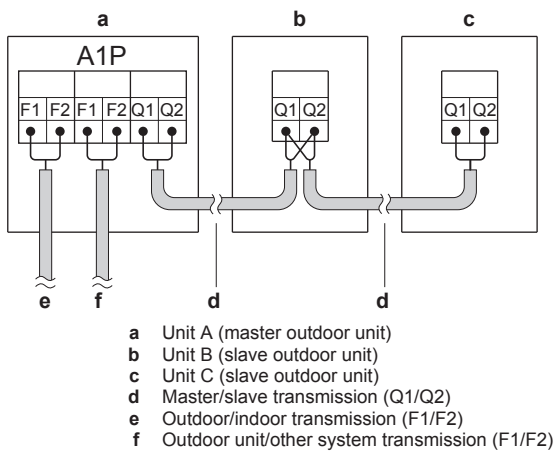

- The interconnecting wiring between the outdoor units in the same piping system must be connected to the Q1/Q2 (Out Multi) terminals. Connecting the wires to the F1/F2 terminals results in system malfunction.
- The wiring for the other systems must be connected to the F1/F2 (Out-Out) terminals of the PCB in the outdoor unit to which the interconnecting wiring for the indoor units is connected.
- The base unit is the outdoor unit to which the interconnecting wiring for the indoor units is connected.

### 5.7.5 To finish the transmission wiring

After installing the transmission wires inside the unit, wrap them along with the on-site refrigerant pipes using finishing tape, as shown in figure below.

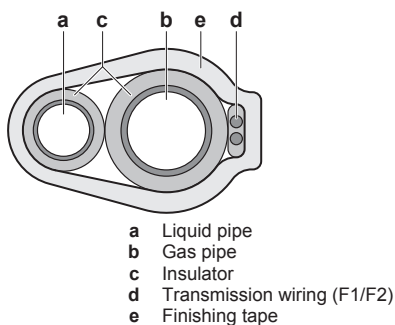

### 5.7.6 To route and fix the power supply



#### NOTICE

When routing earth wires, secure clearance of 25 mm or more away from compressor lead wires. Failure to observe this instruction properly may adversely affect correct operation of other units connected to the same earth.

The power supply wiring can be routed from the front and left side. Fix it to the lower mounting hole.

#### 8~12 HP

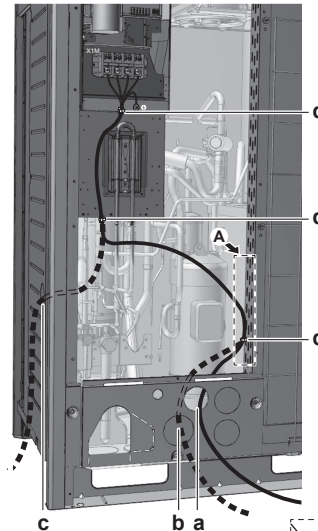

#### 14~20 HP

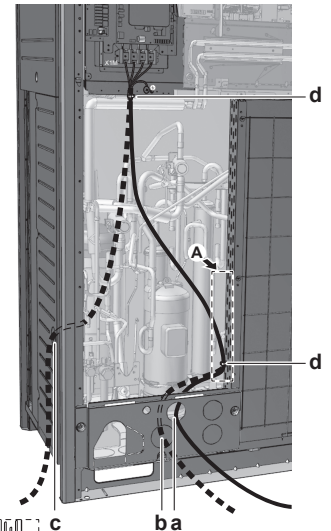

- a Power supply (possibility 1)<sup>(a)</sup>  
 b Power supply (possibility 2)<sup>(a)</sup>  
 c Power supply (possibility 3)<sup>(a)</sup>. Use conduit.  
 d Tie wrap

(a) Knockout hole has to be removed. Close the hole to avoid small animals or dirt from entering.

### 5.7.7 To connect the power supply

The power supply must be clamped to the plastic bracket using field supplied clamp material.

The green and yellow striped wire must be used for earthing only (refer to the figure below).

#### 8~12 HP

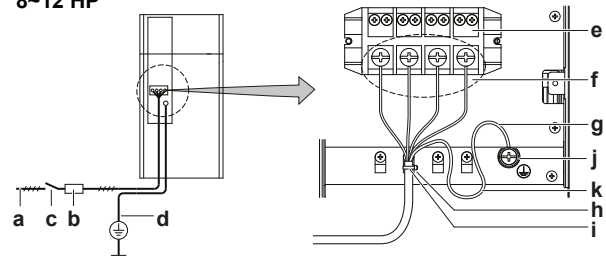



## 6 Configuration

### 14~20 HP

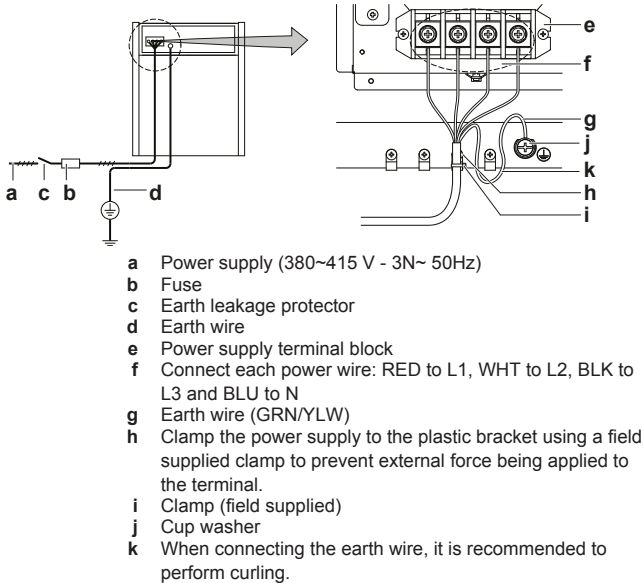

### Multiple outdoor units

To connect the power supply for multiple outdoor units to each other, ring tongues have to be used. No bare cable can be used.

The ring washer which is standard provided should be removed in that case.

Attaching both cables to the power supply terminal should be done as indicated.

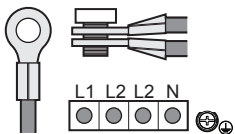

## 6 Configuration



### INFORMATION

It is important that all information in this chapter is read sequentially by the installer and that the system is configured as applicable.



### DANGER: RISK OF ELECTROCUTION

## 6.1 Making field settings

### 6.1.1 About making field settings

To continue the configuration of the VRV IV heat pump system, it is required to give some input to the PCB of the unit. This chapter will describe how manual input is possible by operating the push buttons/DIP switches on the PCB and reading the feedback from the 7-segment displays.

Making settings is done via the master outdoor unit.

Next to making field settings it is also possible to confirm the current operation parameters of the unit.

### Push buttons and DIP switches

Item	Description
Push buttons	By operating the push buttons it is possible to: <ul style="list-style-type: none"> <li>Perform special actions (automatic refrigerant charge, testrun, etc).</li> <li>Perform field settings (demand operation, low noise, etc).</li> </ul>
DIP switches	By operating the DIP switches it is possible to: <ul style="list-style-type: none"> <li>DS1 (1): COOL/HEAT selector (refer to the manual of the cool/heat selector switch). OFF=not installed=factory setting</li> <li>DS1 (2~4): NOT USED. DO NOT CHANGE THE FACTORY SETTING.</li> <li>DS2 (1~4): NOT USED. DO NOT CHANGE THE FACTORY SETTING.</li> </ul>

See also:

- "6.1.2 Field setting components" on page 26
- "6.1.3 To access the field setting components" on page 27

### PC configurator

For VRV IV heat pump system it is alternatively possible to make several commissioning field settings through a personal computer interface (for this, option EKPCCAB is required). The installer can prepare the configuration (off-site) on PC and afterwards upload the configuration to the system.

See also: "6.1.9 To connect the PC configurator to the outdoor unit" on page 29.

### Mode 1 and 2

Mode	Description
Mode 1 (monitoring settings)	Mode 1 can be used to monitor the current situation of the outdoor unit. Some field setting contents can be monitored as well.
Mode 2 (field settings)	<p>Mode 2 is used to change the field settings of the system. Consulting the current field setting value and changing the current field setting value is possible.</p> <p>In general, normal operation can be resumed without special intervention after changing field settings.</p> <p>Some field settings are used for special operation (e.g., 1 time operation, recovery/vacuuming setting, manual adding refrigerant setting, etc.). In such a case, it is required to abort the special operation before normal operation can restart. It will be indicated in below explanations.</p>

See also:

- "6.1.4 To access mode 1 or 2" on page 27
- "6.1.5 To use mode 1" on page 27
- "6.1.6 To use mode 2" on page 27
- "6.1.7 Mode 1: Monitoring settings" on page 28
- "6.1.8 Mode 2: Field settings" on page 28

### 6.1.2 Field setting components

Location of the 7-segment displays, buttons and DIP switches:

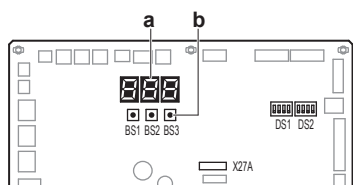

- BS1** MODE: For changing the set mode
- BS2** SET: For field setting
- BS3** RETURN: For field setting
- DS1, DS2** DIP switches
- a** 7-segment displays
- b** Push buttons

## 6.1.3 To access the field setting components

It is not required to open the complete electronic component box to access the push buttons on the PCB and read out the 7-segment display(s).

To access you can remove the front inspection cover of the front plate (see figure). Now you can open the inspection cover of the electrical component box front plate (see figure). You can see the three push buttons and the 3 7-segment displays and DIP switches.

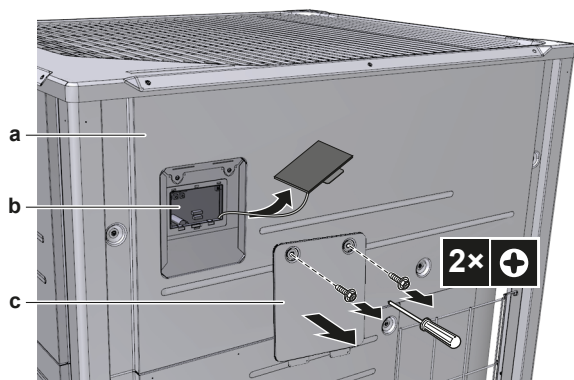

- a** Front plate
- b** Main PCB with 3 7-segment displays and 3 push buttons
- c** Electrical component box service cover

Operate the switches and push buttons with an insulated stick (such as a closed ball-point pen) to avoid touching of live parts.



Make sure to re-attach the inspection cover into the electronic component box cover and to close the front plate's inspection cover after the job is finished. During operation of the unit the front plate of the unit should be attached. Settings are still possible to be made through the inspection opening.

### NOTICE

Make sure that all outside panels, except for the service cover on the electrical component box, are closed while working.

Close the lid of the electrical component box firmly before turning on the power.

## 6.1.4 To access mode 1 or 2

### Initialisation: default situation

### NOTICE

Be sure to turn on the power 6 hours before operation in order to have power running to the crankcase heater and to protect the compressor.

Turn on the power supply of the outdoor unit and all indoor units. When the communication between indoor units and outdoor unit(s) is established and normal, the 7-segment display indication state will be as below (default situation when shipped from factory).

Stage	Display
When turning on the power supply: flashing as indicated. First checks on power supply are executed (1~2 min).	
When no trouble occurs: lighted as indicated (8~10 min).	
Ready for operation: blank display indication as indicated.	

7-segment display indications:

- Off
- Blinking
- On

When above situation cannot be confirmed after 12 min, the malfunction code can be checked on the indoor unit user interface and the outdoor unit 7-segment display. Solve the malfunction code accordingly. The communication wiring should be checked at first.

### Access

BS1 is used to change the mode you want to access.

Access	Action
Mode 1	Push BS1 one time. 7-segment display indication changes to: 
Mode 2	Push BS1 for at least 5 seconds. 7-segment display indication changes to: 



### INFORMATION

If you get confused in the middle of the process, push BS1. Then it returns to idle situation (no indication on 7-segment displays: blank, refer to "6.1.4 To access mode 1 or 2" on page 27.

## 6.1.5 To use mode 1

Mode 1 is used to set basic settings and to monitor the status of the unit.

What	How
Changing and accessing the setting in mode 1	Once mode 1 is selected (push BS1 1 time), you can select the wanted setting. It is done by pushing BS2.  Accessing the selected setting's value is done by pushing BS3 1 time.
To quit and return to the initial status	Press BS1.

## 6.1.6 To use mode 2

The master unit should be used to input field settings in mode 2.

Mode 2 is used to set field settings of the outdoor unit and system.

What	How
Changing and accessing the setting in mode 2	Once mode 2 is selected (push BS1 for more than 5 seconds), you can select the wanted setting. It is done by pushing BS2.  Accessing the selected setting's value is done by pushing BS3 1 time.
To quit and return to the initial status	Press BS1.

## 6 Configuration

What	How
Changing the value of the selected setting in mode 2	<ul style="list-style-type: none"> <li>Once mode 2 is selected (push BS1 for more than 5 seconds) you can select the wanted setting. It is done by pushing BS2.</li> <li>Accessing the selected setting's value is done by pushing BS3 1 time.</li> <li>Now BS2 is used to select the required value of the selected setting.</li> <li>When the required value is selected, you can define the change of value by pushing BS3 1 time.</li> <li>Press BS3 again to start operation according to the chosen value.</li> </ul>

### 6.1.7 Mode 1: Monitoring settings

#### [1-0]

Shows whether the unit you check is a master, slave 1 or slave 2 unit.

The master unit should be used to input field settings in mode 2.

[1-0]	Description
No indication	Undefined situation.
0	Outdoor unit is master unit.
1	Outdoor unit is slave 1 unit.
2	Outdoor unit is slave 2 unit.

#### [1-1]

Shows the status of low noise operation.

[1-1]	Description
0	Unit is currently not operating under low noise restrictions.
1	Unit is currently operating under low noise restrictions.

#### [1-2]

Shows the status of power consumption limitation operation.

[1-2]	Description
0	Unit is currently not operating under power consumption limitations.
1	Unit is currently operating under power consumption limitation.

#### [1-5] [1-6]

Shows:

- [1-5]: The current  $T_e$  target parameter position.
- [1-6]: The current  $T_c$  target parameter position.

#### [1-10]

Shows the total number of connected indoor units.

#### [1-13]

Shows the total number of connected outdoor units (in case of multiple outdoor system).

#### [1-17] [1-18] [1-19]

Shows:

- [1-17]: The latest malfunction code.
- [1-18]: The 2nd last malfunction code.
- [1-19]: The 3rd last malfunction code.

#### [1-29] [1-30] [1-31]

Shows the estimated leaked refrigerant amount (kg) based on:

- [1-29]: The latest leak detection operation.
- [1-30]: The 2nd last leak detection operation.
- [1-31]: The 3rd last leak detection operation.

#### [1-34]

Shows the remaining days till the next automatic leak detection (if automatic leak detection function is activated).

#### [1-35] [1-36] [1-37]

Shows the result of:

- [1-35]: The latest automatic leak detection execution.
- [1-36]: The 2nd last automatic leak detection operation.
- [1-37]: The 3rd last automatic leak detection operation.

[1-35] [1-36] [1-37]	Description
1	Normal execution of leak detection operation occurred.
2	Operation conditions during leak detection operation were not satisfied (ambient temperature was not within the limitations).
3	Malfunction occurred during leak detection operation.

If	Then the estimated leaked refrigerant amount is displayed in
[1-35]=1	[1-29]
[1-36]=1	[1-30]
[1-37]=1	[1-31]

#### [1-38] [1-39]

Shows:

- [1-38]: The number of RA DX indoor units connected to the system.
- [1-39]: The number of Hydrobox (HXY080/125) indoor units connected to the system.

#### [1-40] [1-41]

Shows:

- [1-40]: The current cooling comfort setting.
- [1-41]: The current heating comfort setting.

### 6.1.8 Mode 2: Field settings

#### [2-0]

Cool/Heat selection setting.

[2-0]	Description
0 (default)	Each individual outdoor unit can select Cool/Heat operation (by Cool/Heat selector if installed), or by defining master indoor user interface (see setting [2-83] and the operation manual).
1	Master unit decides Cool/Heat operation when outdoor units are connected in multiple system combination <sup>(a)</sup> .
2	Slave unit for Cool/Heat operation when outdoor units are connected in multiple system combination <sup>(a)</sup> .

- (a) It is necessary to use the optional external control adaptor for outdoor unit (DTA104A61/62). See the instruction delivered with the adaptor for further details.

## [2-8]

T<sub>e</sub> target temperature during cooling operation.

[2-8]	T <sub>e</sub> target (°C)
0 (default)	Auto
2	6
3	7
4	8
5	9
6	10
7	11

## [2-9]

T<sub>c</sub> target temperature during heating operation.

[2-9]	T <sub>c</sub> target (°C)
0 (default)	Auto
1	41
3	43
6	46

## [2-14]

Input additional refrigerant amount that was charged.

In case you want to use the automatic leak detection functionality, it is required to input the total additional refrigerant charge amount.

[2-14]	Additional amount charged (kg)
0 (default)	No input
1	0<x<5
2	5<x<10
3	10<x<15
4	15<x<20
5	20<x<25
6	25<x<30
7	30<x<35
8	35<x<40
9	40<x<45
10	45<x<50
11	50<x<55
12	55<x<60
13	60<x<65
14	65<x<70
15	70<x<75
16	75<x<80
17	80<x<85
18	85<x<90
19	Setting cannot be used. Total refrigerant charge has to be <100 kg.
20	
21	

- For details concerning the calculation of additional refrigerant charge amount, see "5.6.3 To determine the additional refrigerant amount" on page 17.
- For guidance concerning the input of the additional refrigerant charge amount and leak detection function see "6.2 Using the leak detection function" on page 30.

## [2-20]

Manual additional refrigerant charge.

[2-20]	Description
0 (default)	Deactivated.

[2-20]	Description
1	Activated. To stop the manual additional refrigerant charge operation (when the required additional refrigerant amount is charged), push BS3. If this function was not aborted by pushing BS3, the unit will stop its operation after 30 minutes. If 30 minutes was not sufficient to add the needed refrigerant amount, the function can be reactivated by changing the field setting again.

## [2-35]

Height difference setting.

[2-35]	Description
0	In case the outdoor unit is installed in the lowest position (indoor units are installed on a higher position than outdoor units) and the height difference between the highest indoor unit and the outdoor unit exceeds 40 m, the setting [2-35] should be changed to 0.
1 (default)	—

## [2-49]

Height difference setting.

[2-49]	Description
0 (default)	—
1	In case the outdoor unit is installed in the highest position (indoor units are installed on a lower position than outdoor units) and the height difference between the lowest indoor unit and the outdoor unit exceeds 50 m, the setting [2-49] has to be changed to 1.

## [2-83]

Master user interface allocation in case VRV DX indoor units and RA DX indoor units are used at the same time.

[2-83]	Description
0	VRV DX indoor unit has mode selection right.
1 (default)	RA DX indoor unit has mode selection right setting.

### 6.1.9 To connect the PC configurator to the outdoor unit

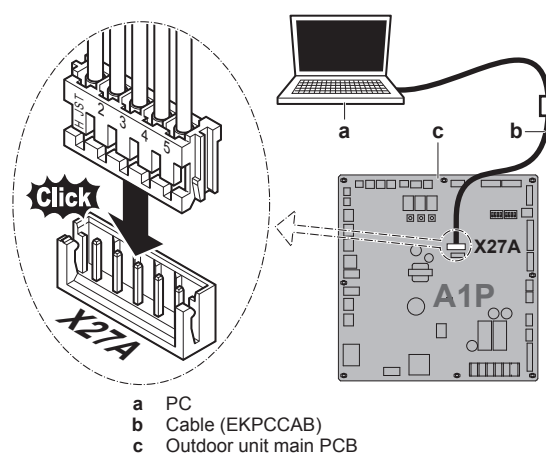

## 7 Commissioning

### 6.2 Using the leak detection function

#### 6.2.1 About automatic leak detection

The (automatic) leak detection function is not by default activated. The (automatic) leak detection function can only start working when both below conditions are fulfilled:

- The additional refrigerant charge was inputted in the system's logic (see [2-14]).
- The system test run was executed (see "7 Commissioning" on page 30), including the detailed refrigerant situation check.

The leak detection operation can be automated. By changing parameter [2-85] to chosen value, the interval time or the time till the next automatic leak detection operation can be chosen. The parameter [2-86] defines whether the leak detection operation is executed one time (within [2-85] days) or intermittent, respecting an interval of [2-85] days.

Availability of the leak detection function feature requires input of the additional refrigerant charge amount immediately after finishing the charging. The input must be executed before performing the test operation.



#### NOTICE

If a wrong value is input for the additional charged refrigerant weight, the accuracy of the leak detection function will decrease.



#### INFORMATION

- The weighed and already recorded amount of additional refrigerant charge (not the total amount of refrigerant present in the system) must be entered.
- The leak detection function is not available when Hydrobox units or RA DX indoor units are connected to the system.
- When the height difference between indoor units is  $\geq 50/40$  m, the leak detection function can not be used.

## 7 Commissioning

After installation and once the field settings are defined, the installer is obliged to verify correct operation. Therefore a test run must be performed according to the procedures described below.

### 7.1 Precautions when commissioning



#### CAUTION

**Do not perform the test operation while working on the indoor units.**

When performing the test operation, not only the outdoor unit, but the connected indoor unit will operate as well. Working on an indoor unit while performing a test operation is dangerous.



#### NOTICE

Be sure to turn on the power 6 hours before operation in order to have power running to the crankcase heater and to protect the compressor.

During test operation, the outdoor unit and the indoor units will start up. Make sure that the preparations of all indoor units are finished (field piping, electrical wiring, air purge, ...). See installation manual of the indoor units for details.

### 7.2 Checklist before commissioning

After the installation of the unit, first check the following items. Once all below checks are fulfilled, the unit must be closed, only then can the unit be powered up.

<input type="checkbox"/>	You read the complete installation and operation instructions, as described in the <b>installer and user reference guide</b> .
<input type="checkbox"/>	<b>Installation</b> Check that the unit is properly installed, to avoid abnormal noises and vibrations when starting up the unit.
<input type="checkbox"/>	<b>Field wiring</b> Be sure that the field wiring has been carried out according to the instructions described in the chapter "5.7 Connecting the electrical wiring" on page 23, according to the wiring diagrams and according to the applicable legislation.
<input type="checkbox"/>	<b>Power supply voltage</b> Check the power supply voltage on the local supply panel. The voltage must correspond to the voltage on the identification label of the unit.
<input type="checkbox"/>	<b>Earth wiring</b> Be sure that the earth wires have been connected properly and that the earth terminals are tightened.
<input type="checkbox"/>	<b>Insulation test of the main power circuit</b> Using a megatester for 500 V, check that the insulation resistance of 2 M $\Omega$ or more is attained by applying a voltage of 500 V DC between power terminals and earth. Never use the megatester for the transmission wiring.
<input type="checkbox"/>	<b>Fuses, circuit breakers, or protection devices</b> Check that the fuses, circuit breakers, or the locally installed protection devices are of the size and type specified in the chapter "4.3.1 Safety device requirements" on page 11. Be sure that neither a fuse nor a protection device has been bypassed.
<input type="checkbox"/>	<b>Internal wiring</b> Visually check the electrical component box and the inside of the unit on loose connections or damaged electrical components.
<input type="checkbox"/>	<b>Pipe size and pipe insulation</b> Be sure that correct pipe sizes are installed and that the insulation work is properly executed.
<input type="checkbox"/>	<b>Stop valves</b> Be sure that the stop valves are open on both liquid and gas side.
<input type="checkbox"/>	<b>Damaged equipment</b> Check the inside of the unit on damaged components or squeezed pipes.
<input type="checkbox"/>	<b>Refrigerant leak</b> Check the inside of the unit on refrigerant leakage. If there is a refrigerant leak, try to repair the leak. If the repair is unsuccessful, call your local dealer. Do not touch any refrigerant which has leaked out from refrigerant piping connections. This may result in frostbite.
<input type="checkbox"/>	<b>Oil leak</b> Check the compressor for oil leakage. If there is an oil leak, try to repair the leak. If the repairing is unsuccessful, call your local dealer.
<input type="checkbox"/>	<b>Air inlet/outlet</b> Check that the air inlet and outlet of the unit is not obstructed by paper sheets, cardboard, or any other material.



<input type="checkbox"/>	<b>Additional refrigerant charge</b> The amount of refrigerant to be added to the unit shall be written on the included "Added refrigerant" plate and attached to the rear side of the front cover.
<input type="checkbox"/>	<b>Installation date and field setting</b> Be sure to keep record of the installation date on the sticker on the rear of the upper front panel according to EN60335-2-40 and keep record of the contents of the field setting(s).

### 7.3 About test run

The procedure below describes the test operation of the complete system. This operation checks and judges following items:

- Check of wrong wiring (communication check with indoor units).
- Check of the stop valves opening.
- Judgement of piping length.
- Gathering reference data for leak detection functionality. If the leak detection functionality is required, the test run needs to be executed including a detailed refrigerant situation check. If the leak detection functionality is NOT required, the test run can skip the detailed refrigerant situation check. This can be defined by setting [2-88].



#### INFORMATION

The refrigerant situation check cannot be performed beyond the following limits:

- Outdoor temperature: 0~43°C DB
- Indoor temperature: 20~32°C DB

Value [2-88]	Description
0	The test run will be executed including the detailed refrigerant situation check. After the test run, the unit will be prepared for leak detection functionality (for more details, see "6.2 Using the leak detection function" on page 30).
1	The test run will be executed without the detailed refrigerant situation check. After the test run, the unit will NOT be prepared for leak detection functionality.



#### INFORMATION

- When [2-88]=0, the test operation time can take up to 4 hours.
- When [2-88]=0 and the test operation was aborted before the end, the U3 warning code will be visible on the user interface. It is possible to operate the system. Leak detection function will NOT be available. It is recommended to re-execute the test operation.
- If the autocharge function was used, the unit informs the user in case unfavourable ambient conditions are present to gather detailed refrigerant situation data. When this is the case, the accuracy of leak detection operation will drop. It is recommended in such a case to perform the test operation again on another more favourable moment. In case no "E-2" or "E-3" information was displayed during the autocharging procedure, it is possible to have reliable data gathering during the test operation. See ambient limitations in the information table on "5.6.6 Step 6a: To automatically charge refrigerant" on page 22.

In case Hydrobox units or RA DX indoor units are present in the system, the pipe length check and the refrigerant situation check will not be performed.

- Make sure to carry out the system test operation after the first installation. Otherwise, the malfunction code U3 will be displayed on the user interface and normal operation or individual indoor unit test run cannot be carried out.
- Abnormalities on indoor units cannot be checked for each unit separately. After the test operation is finished, check the indoor units one by one by performing a normal operation using the user interface. Refer to the indoor unit installation manual for more details (e.g., Hydrobox) concerning the individual test run.



#### INFORMATION

- It may take 10 minutes to achieve a uniform refrigerant state before the compressor starts.
- During the test operation, the refrigerant running sound or the magnetic sound of a solenoid valve may become loud and the display indication may change. These are not malfunctions.

### 7.4 To perform a test run

- 1 Close all front panels in order to not let it be the cause of misjudgement (except the electrical component box inspection opening service cover).
- 2 Make sure all field settings you want are set; see "6.1 Making field settings" on page 26.
- 3 Turn ON the power to the outdoor unit and the connected indoor units.



#### NOTICE

Be sure to turn on the power 6 hours before operation in order to have power running to the crankcase heater and to protect the compressor.

- 4 Make sure the default (idle) situation is existing; see "6.1.4 To access mode 1 or 2" on page 27. Push BS2 for 5 seconds or more. The unit will start test operation.

**Result:** The test operation is automatically carried out, the outdoor unit display will indicate "E0" and the indication "Test operation" and "Under centralised control" will display on the user interface of indoor units.

Steps during the automatic system test run procedure:

Step	Description
E01	Control before start up (pressure equalisation)
E02	Cooling start up control
E03	Cooling stable condition
E04	Communication check
E05	Stop valve check
E06	Pipe length check
E07	Refrigerant amount check
E08	In case [2-88]=0, detailed refrigerant situation check
E09	Pump down operation
E10	Unit stop

**Note:** During the test operation, it is not possible to stop the unit operation from a user interface. To abort the operation, press BS3. The unit will stop after ±30 seconds.

- 5 Check the test operation results on the outdoor unit 7-segment display.

Completion	Description
Normal completion	No indication on the 7-segment display (idle).

## 8 Troubleshooting

Completion	Description
Abnormal completion	Indication of malfunction code on the 7-segment display.  Refer to "7.5 Correcting after abnormal completion of the test run" on page 32 to take actions for correcting the abnormality. When the test operation is fully completed, normal operation will be possible after 5 minutes.

### 7.5 Correcting after abnormal completion of the test run

The test operation is only completed if there is no malfunction code displayed on the user interface or outdoor unit 7-segment display. In case of a displayed malfunction code, perform correcting actions as explained in the malfunction code table. Carry out the test operation again and confirm that the abnormality is properly corrected.



#### INFORMATION

Refer to the installation manual of the indoor unit for detailed malfunction codes related to indoor units.

## 8 Troubleshooting

### 8.1 Solving problems based on error codes

In case of a displayed malfunction code, perform correcting actions as explained in the malfunction code table.

After correcting the abnormality, press BS3 to reset the malfunction code and retry operation.

The malfunction code which is displayed on the outdoor unit will indicate a main malfunction code and a sub code. The sub code indicates more detailed information about the malfunction code. The malfunction code will be displayed intermittent.

**Example:**

Code	Example
Main code	E3
Sub code	-01

With an interval of 1 second, the display will switch between main code and sub code.

### 8.2 Error codes: Overview

Main code	Sub code			Cause	Solution
	Master	Slave 1	Slave 2		
E3	-01	-03	-05	High pressure switch was activated (S1PH, S2PH) - A1P (X3A; X4A)	Check stop valve situation or abnormalities in (field) piping or airflow over air cooled coil.
	-02	-04	-06	<ul style="list-style-type: none"> <li>Refrigerant overcharge</li> <li>Stop valve closed</li> </ul>	<ul style="list-style-type: none"> <li>Check refrigerant amount+recharge unit.</li> <li>Open stop valves</li> </ul>
	-13	-14	-15	Stop valve closed (liquid)	Open liquid stop valve.
		-18		<ul style="list-style-type: none"> <li>Refrigerant overcharge</li> <li>Stop valve closed</li> </ul>	<ul style="list-style-type: none"> <li>Check refrigerant amount+recharge unit.</li> <li>Open stop valves.</li> </ul>
E4	-01	-02	-03	Low pressure malfunction: <ul style="list-style-type: none"> <li>Stop valve closed</li> <li>Refrigerant shortage</li> <li>Indoor unit malfunction</li> </ul>	<ul style="list-style-type: none"> <li>Open stop valves.</li> <li>Check refrigerant amount+recharge unit.</li> <li>Check the user interface's display or transmission wiring between the outdoor unit and the indoor unit.</li> </ul>
E9	-01	-05	-08	Electronic expansion valve malfunction (subcool) (Y2E) - A1P (X21A)	Check connection on PCB or actuator.
	-04	-07	-10	Electronic expansion valve malfunction (main) (Y1E) - A1P (X23A)	Check connection on PCB or actuator.
	-03	-06	-09	Electronic expansion valve malfunction (storage vessel) (Y3E) - A1P (X22A)	Check connection on PCB or actuator
F3	-01	-03	-05	Discharge temperature too high (R21T/R22T): <ul style="list-style-type: none"> <li>Stop valve closed</li> <li>Refrigerant shortage</li> </ul>	<ul style="list-style-type: none"> <li>Open stop valves.</li> <li>Check refrigerant amount+recharge unit.</li> </ul>
	-20	-21	-22	Compressor casing temperature too high (R8T): <ul style="list-style-type: none"> <li>Stop valve closed</li> <li>Refrigerant shortage</li> </ul>	<ul style="list-style-type: none"> <li>Open stop valves.</li> <li>Check refrigerant amount+recharge unit.</li> </ul>
F6		-02		<ul style="list-style-type: none"> <li>Refrigerant overcharge</li> <li>Stop valve closed</li> </ul>	<ul style="list-style-type: none"> <li>Check refrigerant amount+recharge unit.</li> <li>Open stop valves.</li> </ul>

## 8 Troubleshooting

Main code	Sub code			Cause	Solution
	Master	Slave 1	Slave 2		
H9	-01	-02	-03	Ambient temperature sensor malfunction (R1T) - A1P (X18A)	Check connection on PCB or actuator.
J3	-16	-22	-28	Discharge temperature sensor malfunction (R21T): open circuit - A1P (X29A)	Check connection on PCB or actuator.
	-17	-23	-29	Discharge temperature sensor malfunction (R21T): short circuit - A1P (X29A)	Check connection on PCB or actuator.
	-18	-24	-30	Discharge temperature sensor malfunction (R22T): open circuit - A1P (X29A)	Check connection on PCB or actuator.
	-19	-25	-31	Discharge temperature sensor malfunction (R22T): short circuit - A1P (X29A)	Check connection on PCB or actuator.
	-47	-49	-51	Compressor casing temperature sensor malfunction (R8T): open circuit - A1P (X29A)	Check connection on PCB or actuator.
	-48	-50	-52	Compressor casing temperature sensor malfunction (R8T): short circuit - A1P (X29A)	Check connection on PCB or actuator.
J5	-01	-03	-05	Suction temperature sensor malfunction (R3T) - A1P (X30A)	Check connection on PCB or actuator.
J6	-01	-02	-03	De-icing temperature sensor malfunction (R7T) - A1P (X30A)	Check connection on PCB or actuator.
J7	-06	-07	-08	Liquid temperature sensor (after subcool HE) malfunction (R5T) - A1P (X30A)	Check connection on PCB or actuator.
J8	-01	-02	-03	Liquid temperature sensor (coil) malfunction (R4T) - A1P (X30A)	Check connection on PCB or actuator.
J9	-01	-02	-03	Gas temperature sensor (after subcool HE) malfunction (R6T) - A1P (X30A)	Check connection on PCB or actuator.
JA	-06	-08	-10	High pressure sensor malfunction (S1NPH): open circuit - A1P (X32A)	Check connection on PCB or actuator.
	-07	-09	-11	High pressure sensor malfunction (S1NPH): short circuit - A1P (X32A)	Check connection on PCB or actuator.
JC	-06	-08	-10	Low pressure sensor malfunction (S1NPL): open circuit - A1P (X31A)	Check connection on PCB or actuator.
	-07	-09	-11	Low pressure sensor malfunction (S1NPL): short circuit - A1P (X31A)	Check connection on PCB or actuator.
LC	-14			Transmission outdoor unit - inverter: INV1 transmission trouble - A1P (X20A, X28A, X40A)	Check connection.
	-19			Transmission outdoor unit - inverter: FAN1 transmission trouble - A1P (X20A, X28A, X40A)	Check connection.
	-24			Transmission outdoor unit - inverter: FAN2 transmission trouble - A1P (X20A, X28A, X40A)	Check connection.
	-30			Transmission outdoor unit - inverter: INV2 transmission trouble - A1P (X20A, X28A, X40A)	Check connection.
P1	-01	-02	-03	INV1 unbalanced power supply voltage	Check if power supply is within range.
	-07	-08	-09	INV2 unbalanced power supply voltage	Check if power supply is within range.
U1	-01	-05	-07	Reversed power supply phase malfunction	Correct phase order.
	-04	-06	-08	Reversed power supply phase malfunction	Correct phase order.

## 8 Troubleshooting

Main code	Sub code			Cause	Solution
	Master	Slave 1	Slave 2		
U2	-01	-08	-11	INV1 voltage power shortage	Check if power supply is within range.
	-02	-09	-12	INV1 power phase loss	Check if power supply is within range.
	-22	-25	-28	INV2 voltage power shortage	Check if power supply is within range.
	-23	-26	-29	INV2 power phase loss	Check if power supply is within range.
U3	-02			Warning indication: Leak detection or refrigerant amount check not performed (system operation possible)	Execute autocharge function (see manual); unit not ready for leak detection functionality.
	-03			Malfunction code: System test run not yet executed (system operation not possible)	Execute system test run.
U4	-01			Faulty wiring to Q1/Q2 or indoor - outdoor	Check (Q1/Q2) wiring.
	-03			Faulty wiring to Q1/Q2 or indoor - outdoor	Check (Q1/Q2) wiring.
	-04			System test run abnormal ending	Execute test run again.
U7	-01			Warning: faulty wiring to Q1/Q2	Check Q1/Q2 wiring.
	-02			Malfunction code: faulty wiring to Q1/Q2	Check Q1/Q2 wiring.
	-11			<ul style="list-style-type: none"> <li>▪ Too many indoor units are connected to F1/F2 line</li> <li>▪ Bad wiring between outdoor and indoor units</li> </ul>	Check indoor unit amount and total capacity connected.
U9	-01			System mismatch. Wrong type of indoor units combined (R410A, R407C, RA, Hydrobox, etc) Indoor unit malfunction	Check if other indoor units have malfunction and confirm indoor unit mix is allowed.
UR	-03			Connection malfunction over indoor units or type mismatch (R410A, R407C, RA, Hydrobox, etc)	Check if other indoor units have malfunction and confirm indoor unit mix is allowed.
	-18			Connection malfunction over indoor units or type mismatch (R410A, R407C, RA, Hydrobox, etc)	Check if other indoor units have malfunction and confirm indoor unit mix is allowed.
	-31			Wrong unit combination (multi system)	Check if unit types are compatible.
	-49			Wrong unit combination (multi system)	Check if unit types are compatible.
UH	-01			Auto address malfunction (inconsistency)	Check if transmission wired unit amount matches with powered unit amount (by monitor mode) or wait till initialisation is finished.
UF	-01			Auto address malfunction (inconsistency)	Check if transmission wired unit amount matches with powered unit amount (by monitor mode) or wait till initialisation is finished.
	-05			Stop valve closed or wrong (during system test run)	Open stop valves.
<b>Auto charging related</b>					
P2	—			Unusual low pressure on suction line	Close valve A immediately. Push BS1 to reset. Check following items before retrying autocharge procedure: <ul style="list-style-type: none"> <li>▪ Check if the gas side stop valve is opened correctly.</li> <li>▪ Check if the valve of the refrigerant cylinder is opened.</li> <li>▪ Check if the air inlet and outlet of the indoor unit are not obstructed.</li> </ul>
P8	—			Freeze-up prevention indoor unit	Close valve A immediately. Push BS1 to reset. Retry autocharge procedure.
PE	—			Automatic charging nearly finished	Prepare for autocharge stopping.
P9	—			Automatic charging finished	Finish autocharge mode.
<b>Leak detection function related</b>					

Main code	Sub code			Cause	Solution
	Master	Slave 1	Slave 2		
E-1	—			Unit is not prepared to execute leak detection operation	Refer to requirements to be able to execute leak detection operation.
E-2	—			Indoor unit is out of temperature range for leak detection operation	Retry when ambient conditions are satisfied.
E-3	—			Outdoor unit is out of temperature range for leak detection operation	Retry when ambient conditions are satisfied.
E-4	—			Too low pressure was noticed during leak detection operation	Restart leak detection operation.
E-5	—			Indicates an indoor unit which is not compatible with leak detection functionality is installed (e.g., RA DX indoor unit, Hydrobox, ...)	Refer to requirements to be able to execute leak detection operation.

## 9 Technical data

A **subset** of the latest technical data is available on the regional Daikin website (publicly accessible). The **full set** of latest technical data is available on the Daikin extranet (authentication required).

### 9.1 Service space: Outdoor unit

Make sure the space around the unit is adequate for servicing and the minimum space for air inlet and air outlet is available (refer to the figure below and choose one of the possibilities).

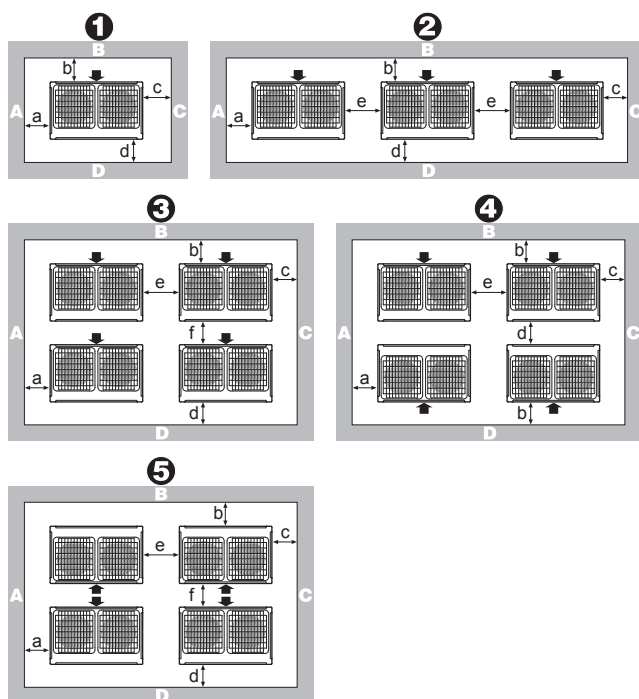

Layout	A+B+C+D		A+B
	Possibility 1	Possibility 2	
1	a ≥ 10 mm b ≥ 300 mm c ≥ 10 mm d ≥ 500 mm	a ≥ 50 mm b ≥ 100 mm c ≥ 50 mm d ≥ 500 mm	a ≥ 200 mm b ≥ 300 mm
2	a ≥ 10 mm b ≥ 300 mm c ≥ 10 mm d ≥ 500 mm e ≥ 20 mm	a ≥ 50 mm b ≥ 100 mm c ≥ 50 mm d ≥ 500 mm e ≥ 100 mm	a ≥ 200 mm b ≥ 300 mm

Layout	A+B+C+D		A+B
	Possibility 1	Possibility 2	
3	a ≥ 10 mm b ≥ 300 mm c ≥ 10 mm d ≥ 500 mm e ≥ 20 mm f ≥ 600 mm	a ≥ 50 mm b ≥ 100 mm c ≥ 50 mm d ≥ 500 mm e ≥ 100 mm f ≥ 500 mm	—
4	a ≥ 10 mm b ≥ 300 mm c ≥ 10 mm d ≥ 500 mm e ≥ 20 mm	a ≥ 50 mm b ≥ 100 mm c ≥ 50 mm d ≥ 500 mm e ≥ 100 mm	—
5	a ≥ 10 mm b ≥ 500 mm c ≥ 10 mm d ≥ 500 mm e ≥ 20 mm f ≥ 900 mm	a ≥ 50 mm b ≥ 500 mm c ≥ 50 mm d ≥ 500 mm e ≥ 100 mm f ≥ 600 mm	—

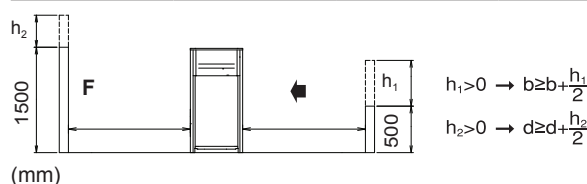

ABCD Sides along the installation site with obstacles  
 F Sides along the installation site with obstacles  
 Suction side

- In case of an installation site where sides A+B+C+D have obstacles, the wall heights of sides A+C have no impact on service space dimensions. Refer to the figure above for impact of wall heights of sides B+D on service space dimensions.
- In case of an installation site where only the sides A+B have obstacles, the wall heights have no influence on any indicated service space dimensions.





Piping diagram: RXYQ14~20

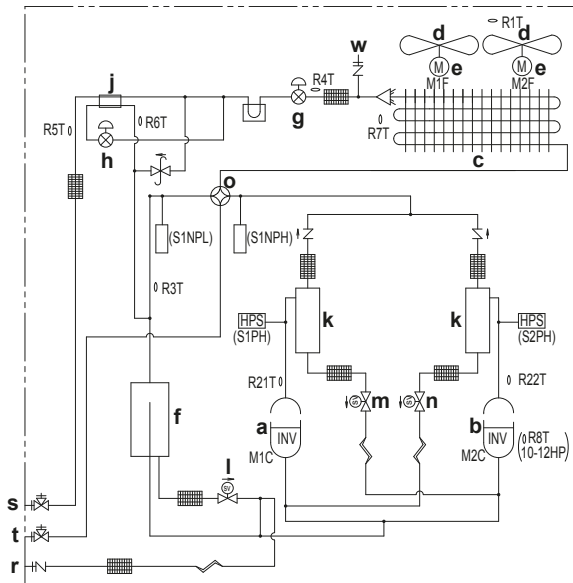

- a Compressor (M1C)
- b Compressor (M2C)
- c Heat exchanger
- d Fan
- e Fan motor (M1F, M2F)
- f Accumulator
- g Expansion valve, main (Y1E)
- h Expansion valve, subcool heat exchanger (Y2E)
- i Expansion valve, storage vessel (Y3E)
- j Subcool heat exchanger
- k Oil separator
- l Solenoid valve, oil accumulator (Y2S)
- m Solenoid valve, oil1 (Y3S)
- n Solenoid valve, oil2 (Y4S)
- o 4-way valve, main (Y1S)
- p 4-way valve, sub (Y5S)
- q Electrical component box
- r Service port, refrigerant charge
- s Stop valve, liquid
- t Stop valve, gas
- u Stop valve, equalising gas
- v Heat accumulation element
- w Service port

**For the user**

**10 About the system**

The indoor unit part of VRV IV heat pump system can be used for heating/cooling applications. The type of indoor unit which can be used depends on the outdoor units series.

**NOTICE**  
Do not use the system for other purposes. In order to avoid any quality deterioration, do not use the unit for cooling precision instruments, food, plants, animals or works of art.

**NOTICE**  
For future modifications or expansions of your system:  
A full overview of allowable combinations (for future system extensions) is available in technical engineering data and should be consulted. Contact your installer to receive more information and professional advice.

**10.1 System layout**

Your VRV IV heat pump series outdoor unit can be one of following models:

Model	Description
RYYQ	Single continuous heating model.
RYMQ	Multi continuous heating model.
RXYQ	Single and multi non-continuous heating model.

Depending on the type of outdoor unit which is chosen, some functionality will or will not exist. It will be indicated throughout this operation manual when certain features have exclusive model rights or not.

**11 User interface**

**CAUTION**  
Never touch the internal parts of the controller.  
Do not remove the front panel. Some parts inside are dangerous to touch and appliance problems may happen. For checking and adjusting the internal parts, contact your dealer.

This operation manual will give a non-exhaustive overview of the main functions of the system.

Detailed information on required actions to achieve certain functions can be found in the dedicated installation and operation manual of the indoor unit.

Refer to the operation manual of the installed user interface.

**12 Operation**

**12.1 Operation range**

Use the system in the following temperature and humidity ranges for safe and effective operation.

	Cooling	Heating
Outdoor temperature	-5~43°C DB	-20~21°C DB -20~15.5°C WB
Indoor temperature	21~32°C DB 14~25°C WB	15~27°C DB
Indoor humidity	≤80% <sup>(a)</sup>	

(a) To avoid condensation and water dripping out of the unit. If the temperature or the humidity is beyond these conditions, safety devices may be put in action and the air conditioner may not operate.

Above operation range is only valid in case direct expansion indoor units are connected to the VRV IV system.

## 12 Operation

Special operation ranges are valid in case of using Hydrobox units or AHU. They can be found in the installation/operation manual of the dedicated unit. Latest information can be found in the technical engineering data.

### 12.2 Operating the system

#### 12.2.1 About operating the system

- Operation procedure varies according to the combination of outdoor unit and user interface.
- To protect the unit, turn on the main power switch 6 hours before operation.
- If the main power supply is turned off during operation, operation will restart automatically after the power turns back on again.

#### 12.2.2 About cooling, heating, fan only, and automatic operation

- Changeover cannot be made with a user interface whose display shows "change-over under centralised control" (refer to installation and operation manual of the user interface).
- When the display "change-over under centralised control" flashes, refer to "12.5.1 About setting the master user interface" on page 39.
- The fan may keep on running for about 1 minute after the heating operation stops.
- The air flow rate may adjust itself depending on the room temperature or the fan may stop immediately. This is not a malfunction.

#### 12.2.3 About the heating operation

It may take longer to reach the set temperature for general heating operation than for cooling operation.

The following operation is performed in order to prevent the heating capacity from dropping or cold air from blowing.

##### Defrost operation

In heating operation, freezing of the outdoor unit's air cooled coil increases over time, restricting the energy transfer to the outdoor unit's coil. Heating capability decreases and the system needs to go into defrost operation to be able to deliver enough heat to the indoor units.

If	Then
RYYQ or RYMQ outdoor unit is installed	The indoor unit will continue heating operation at a reduced level during defrost operation. It will guarantee a decent comfort level indoor. A heat storage element in the outdoor unit will provide the energy to de-ice the outdoor unit's air cooled coil during defrost operation.
RXYQ outdoor unit is installed	The indoor unit will stop fan operation, the refrigerant cycle will reverse and energy from inside the building will be used to defrost the outdoor unit coil.

The indoor unit will indicate defrost operation on the displays

##### Hot start

In order to prevent cold air from blowing out of an indoor unit at the start of heating operation, the indoor fan is automatically stopped. The display of the user interface shows . It may take some time before the fan starts. This is not a malfunction.

#### 12.2.4 To operate the system (WITHOUT cool/heat changeover remote control switch)

- 1 Press the operation mode selector button on the user interface several times and select the operation mode of your choice.

- Cooling operation
- Heating operation
- Fan only operation

- 2 Press the ON/OFF button on the user interface.

**Result:** The operation lamp lights up and the system starts operating.

#### 12.2.5 To operate the system (WITH cool/heat changeover remote control switch)

##### Overview of the changeover remote control switch

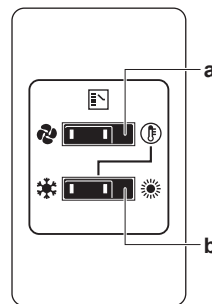

##### a FAN ONLY/AIR CONDITIONING SELECTOR SWITCH

Set the switch to for fan only operation or to for heating or cooling operation.

##### b COOL/HEAT CHANGEOVER SWITCH

Set the switch to for cooling or to for heating

##### To start

- 1 Select operation mode with the cool/heat changeover switch as follows:

Cooling operation

Heating operation

Fan only operation

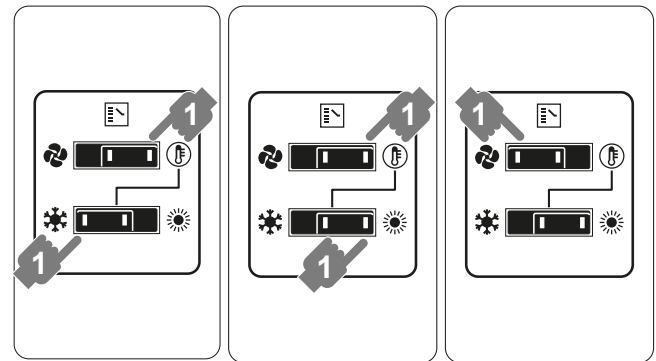

- 2 Press the ON/OFF button on the user interface.

**Result:** The operation lamp lights up and the system starts operating.

##### To stop

- 3 Press the ON/OFF button on the user interface once again.

**Result:** The operation lamp goes out and the system stops operating.



##### NOTICE

Do not turn off power immediately after the unit stops, but wait for at least 5 minutes.

##### To adjust

For programming temperature, fan speed and air flow direction refer to the operation manual of the user interface.

## 12.3 Using the dry program

### 12.3.1 About the dry program

- The function of this program is to decrease the humidity in your room with minimal temperature decrease (minimal room cooling).
- The micro computer automatically determines temperature and fan speed (cannot be set by the user interface).
- The system does not go into operation if the room temperature is low (<20°C).

### 12.3.2 To use the dry program (WITHOUT cool/heat changeover remote control switch)

#### To start

- 1 Press the operation mode selector button on the user interface several times and select  (program dry operation).
- 2 Press the ON/OFF button of the user interface.  
**Result:** The operation lamp lights up and the system starts operating.
- 3 Press the air flow direction adjust button (only for double-flow, multi-flow, corner, ceiling-suspended and wall-mounted). Refer to "12.4 Adjusting the air flow direction" on page 39 for details.

#### To stop

- 4 Press the ON/OFF button on the user interface once again.  
**Result:** The operation lamp goes out and the system stops operating.



#### NOTICE

Do not turn off power immediately after the unit stops, but wait for at least 5 minutes.

### 12.3.3 To use the dry program (WITH cool/heat changeover remote control switch)

#### To start

- 1 Select cooling operation mode with the cool/heat changeover remote control switch.

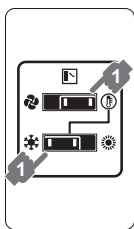

- 2 Press the operation mode selector button on the user interface several times and select  (program dry operation).
- 3 Press the ON/OFF button of the user interface.  
**Result:** The operation lamp lights up and the system starts operating.
- 4 Press the air flow direction adjust button (only for double-flow, multi-flow, corner, ceiling-suspended and wall-mounted). Refer to "12.4 Adjusting the air flow direction" on page 39 for details.

#### To stop

- 5 Press the ON/OFF button on the user interface once again.  
**Result:** The operation lamp goes out and the system stops operating.



#### NOTICE

Do not turn off power immediately after the unit stops, but wait for at least 5 minutes.

## 12.4 Adjusting the air flow direction

Refer to the operation manual of the user interface.

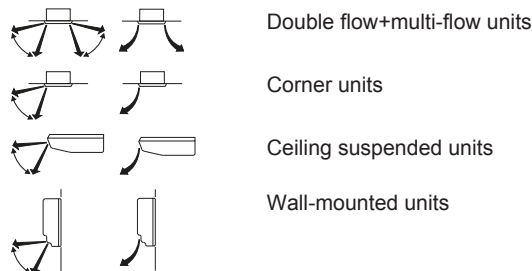

### 12.4.1 About the air flow flap



For the following conditions, a micro computer controls the air flow direction which may be different from the display.

Cooling	Heating
<ul style="list-style-type: none"> <li>• When the room temperature is lower than the set temperature.</li> </ul>	<ul style="list-style-type: none"> <li>• When starting operation.</li> <li>• When the room temperature is higher than the set temperature.</li> <li>• At defrost operation.</li> </ul>
<ul style="list-style-type: none"> <li>• When operating continuously at horizontal air flow direction.</li> <li>• When continuous operation with downward air flow is performed at the time of cooling with a ceiling-suspended unit, the micro computer may control the flow direction, and then the user interface indication will also change.</li> </ul>	

The air flow direction can be adjusted in one of the following ways:

- The air flow flap itself adjusts its position.
- The air flow direction can be fixed by the user.
- Automatic  and desired position .



#### WARNING

Never touch the air outlet or the horizontal blades while the swing flap is in operation. Fingers may become caught or the unit may break down.



#### NOTICE

- The movable limit of the flap is changeable. Contact your dealer for details. (only for double-flow, multi-flow, corner, ceiling-suspended and wall-mounted).
- Avoid operating in the horizontal direction . It may cause dew or dust to settle on the ceiling or flap.

## 12.5 Setting the master user interface

### 12.5.1 About setting the master user interface

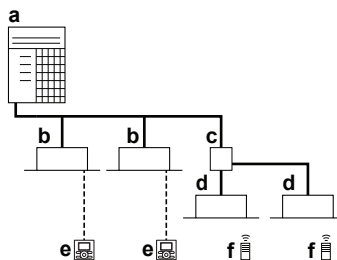

- a VRV heat pump outdoor unit
- b VRV direct expansion (DX) indoor unit
- c BP box (required to connect Residential Air (RA) or Sky Air (SA) Direct Expansion (DX) indoor units)
- d Residential Air (RA) Direct Expansion (DX) indoor units

## 13 Maintenance and service

- e User interface (dedicated depending on indoor unit type)
- f User interface (wireless, dedicated depending on indoor unit type)

When the system is installed as shown in the figure above, it is necessary to designate one of the user interfaces as the master user interface.

The displays of slave user interfaces show  (change-over under centralised control) and slave user interfaces automatically follow the operation mode directed by the master user interface.

Only the master user interface can select heating or cooling mode.

## 13 Maintenance and service

### NOTICE

Never inspect or service the unit by yourself. Ask a qualified service person to perform this work.

### WARNING

Never replace a fuse with a fuse of a wrong ampere ratings or other wires when a fuse blows out. Use of wire or copper wire may cause the unit to break down or cause a fire.

### CAUTION

Do not insert fingers, rods or other objects into the air inlet or outlet. Do not remove the fan guard. When the fan is rotating at high speed, it will cause injury.

### CAUTION

After a long use, check the unit stand and fitting for damage. If damaged, the unit may fall and result in injury.

### NOTICE

Do not wipe the controller operation panel with benzene, thinner, chemical dust cloth, etc. The panel may get discoloured or the coating peeled off. If it is heavily dirty, soak a cloth in water-diluted neutral detergent, squeeze it well and wipe the panel clean. Wipe it with another dry cloth.

## 13.1 About the refrigerant

This product contains fluorinated greenhouse gases. Do NOT vent gases into the atmosphere.

Refrigerant type: R410A

Global warming potential (GWP) value: 2087.5

### NOTICE

In Europe, the **greenhouse gas emissions** of the total refrigerant charge in the system (expressed as tonnes CO<sub>2</sub>-equivalent) is used to determine the maintenance intervals. Follow the applicable legislation.

**Formula to calculate the greenhouse gas emissions:**  
GWP value of the refrigerant × Total refrigerant charge [in kg] / 1000

Please contact your installer for more information.

### WARNING

The refrigerant in the system is safe and normally does not leak. If the refrigerant leaks in the room, contact with a fire of a burner, a heater or a cooker may result in a harmful gas.

Turn off any combustible heating devices, ventilate the room and contact the dealer where you purchased the unit.

Do not use the system until a service person confirms that the portion where the refrigerant leaks is repaired.

## 13.2 After-sales service and warranty

### 13.2.1 Warranty period

- This product includes a warranty card that was filled in by the dealer at the time of installation. The completed card has to be checked by the customer and stored carefully.
- If repairs to the product are necessary within the warranty period, contact your dealer and keep the warranty card at hand.

### 13.2.2 Recommended maintenance and inspection

Since dust collects when using the unit for several years, performance of the unit will deteriorate to some extent. As taking apart and cleaning interiors of units requires technical expertise and in order to ensure the best possible maintenance of your units, we recommend to enter into a maintenance and inspection contract on top of normal maintenance activities. Our network of dealers has access to a permanent stock of essential components in order to keep your unit in operation as long as possible. Contact your dealer for more information.

**When asking your dealer for an intervention, always state:**

- The complete model name of the unit.
- The manufacturing number (stated on the nameplate of the unit).
- The installation date.
- The symptoms or malfunction, and details of the defect.

### WARNING

- Do not modify, disassemble, remove, reinstall or repair the unit yourself as incorrect dismantling or installation may cause an electric shock or fire. Contact your dealer.
- In case of accidental refrigerant leaks, make sure there are no naked flames. The refrigerant itself is entirely safe, non-toxic and non-combustible, but it will generate toxic gas when it accidentally leaks into a room where combustible air from fan heaters, gas cookers, etc. is present. Always have qualified service personnel confirm that the point of leakage has been repaired or corrected before resuming operation.

## 14 Troubleshooting

If one of the following malfunctions occur, take the measures shown below and contact your dealer.

### WARNING

**Stop operation and shut off the power if anything unusual occurs (burning smells etc.).**

Leaving the unit running under such circumstances may cause breakage, electric shock or fire. Contact your dealer.

The system must be repaired by a qualified service person:



Malfunction	Measure
If a safety device such as a fuse, a breaker or an earth leakage breaker frequently actuates or the ON/OFF switch does not properly work.	Turn off the main power switch.
If water leaks from the unit.	Stop the operation.
The operation switch does not work well.	Turn off the power.
If the user interface display indicates the unit number, the operation lamp flashes and the malfunction code appears.	Notify your installer and report the malfunction code.

If the system does not properly operate except for the above mentioned cases and none of the above mentioned malfunctions is evident, investigate the system according to the following procedures.

Malfunction	Measure
If the system does not operate at all.	<ul style="list-style-type: none"> <li>Check if there is no power failure. Wait until power is restored. If power failure occurs during operation, the system automatically restarts immediately after the power supply is recovered.</li> <li>Check if no fuse has blown or breaker has worked. Change the fuse or reset the breaker if necessary.</li> </ul>
If the system goes into fan only operation, but as soon as it goes into heating or cooling operation, the system stops.	<ul style="list-style-type: none"> <li>Check if air inlet or outlet of outdoor or indoor unit is not blocked by obstacles. Remove any obstacle and make it well-ventilated.</li> <li>Check if the user interface display shows  (time to clean the air filter). (Refer to "13 Maintenance and service" on page 40 and "Maintenance" in the indoor unit manual.)</li> </ul>
The system operates but cooling or heating is insufficient.	<ul style="list-style-type: none"> <li>Check if air inlet or outlet of outdoor or indoor unit is not blocked by obstacles. Remove any obstacle and make it well-ventilated.</li> <li>Check if the air filter is not clogged (refer to "Maintenance" in the indoor unit manual).</li> <li>Check the temperature setting.</li> <li>Check the fan speed setting on your user interface.</li> <li>Check for open doors or windows. Shut doors and windows to prevent wind from coming in.</li> <li>Check if there are too many occupants in the room during cooling operation. Check if the heat source of the room is excessive.</li> <li>Check if direct sunlight enters the room. Use curtains or blinds.</li> <li>Check if the air flow angle is proper.</li> </ul>

If after checking all above items, it is impossible to fix the problem yourself, contact your installer and state the symptoms, the complete model name of the unit (with manufacturing number if possible) and the installation date (possibly listed on the warranty card).

## 14.1 Error codes: Overview

In case a malfunction code appears on the indoor unit user interface display, contact your installer and inform the malfunction code, the unit type, and serial number (you can find this information on the nameplate of the unit).

For your reference, a list with malfunction codes is provided. You can, depending on the level of the malfunction code, reset the code by pushing the ON/OFF button. If not, ask your installer for advice.

Main code	Contents
<i>R0</i>	External protection device was activated
<i>R1</i>	EEPROM failure (indoor)
<i>R3</i>	Drain system malfunction (indoor)
<i>Rb</i>	Fan motor malfunction (indoor)
<i>R7</i>	Swing flap motor malfunction (indoor)
<i>R9</i>	Expansion valve malfunction (indoor)
<i>RF</i>	Drain malfunction (indoor unit)
<i>RH</i>	Filter dust chamber malfunction (indoor)
<i>RJ</i>	Capacity setting malfunction (indoor)
<i>C1</i>	Transmission malfunction between main PCB and sub PCB (indoor)
<i>C4</i>	Heat exchanger thermistor malfunction (indoor; liquid)
<i>C5</i>	Heat exchanger thermistor malfunction (indoor; gas)
<i>C9</i>	Suction air thermistor malfunction (indoor)
<i>CR</i>	Discharge air thermistor malfunction (indoor)
<i>CE</i>	Movement detector or floor temperature sensor malfunction (indoor)
<i>CJ</i>	User interface thermistor malfunction (indoor)
<i>E1</i>	PCB malfunction (outdoor)
<i>E2</i>	Current leakage detector was activated (outdoor)
<i>E3</i>	High pressure switch was activated
<i>E4</i>	Low pressure malfunction (outdoor)
<i>E5</i>	Compressor lock detection (outdoor)
<i>E7</i>	Fan motor malfunction (outdoor)
<i>E9</i>	Electronic expansion valve malfunction (outdoor)
<i>F3</i>	Discharge temperature malfunction (outdoor)
<i>F4</i>	Abnormal suction temperature (outdoor)
<i>Fb</i>	Refrigerant overcharge detection
<i>H3</i>	High pressure switch malfunction
<i>H4</i>	Low pressure switch malfunction
<i>H7</i>	Fan motor trouble (outdoor)
<i>H9</i>	Ambient temperature sensor malfunction (outdoor)
<i>J1</i>	Pressure sensor malfunction
<i>J2</i>	Current sensor malfunction
<i>J3</i>	Discharge temperature sensor malfunction (outdoor)
<i>J4</i>	Heat exchanger gas temperature sensor malfunction (outdoor)
<i>J5</i>	Suction temperature sensor malfunction (outdoor)
<i>Jb</i>	De-icing temperature sensor malfunction (outdoor)
<i>J7</i>	Liquid temperature sensor (after subcool HE) malfunction (outdoor)
<i>J8</i>	Liquid temperature sensor (coil) malfunction (outdoor)
<i>J9</i>	Gas temperature sensor (after subcool HE) malfunction (outdoor)
<i>JA</i>	High pressure sensor malfunction (S1NPH)
<i>JC</i>	Low pressure sensor malfunction (S1NPL)
<i>L1</i>	INV PCB abnormal
<i>L4</i>	Fin temperature abnormal

## 14 Troubleshooting

Main code	Contents
L5	Inverter PCB faulty
L8	Compressor over current detected
L9	Compressor lock (startup)
LC	Transmission outdoor unit - inverter: INV transmission trouble
P1	INV unbalanced power supply voltage
P2	Autocharge operation related
P4	Fin thermistor malfunction
P8	Autocharge operation related
P9	Autocharge operation related
PE	Autocharge operation related
PJ	Capacity setting malfunction (outdoor)
UD	Abnormal low pressure drop, faulty expansion valve
U1	Reversed power supply phase malfunction
U2	INV voltage power shortage
U3	System test run not yet executed
U4	Faulty wiring indoor/outdoor
U5	Abnormal user interface - indoor communication
U7	Faulty wiring to outdoor/outdoor
U8	Abnormal main-sub user interface communication
U9	System mismatch. Wrong type of indoor units combined. Indoor unit malfunction.
UR	Connection malfunction over indoor units or type mismatch
UC	Centralised address duplication
UE	Malfunction in communication centralised control device - indoor unit
UF	Auto address malfunction (inconsistency)
UH	Auto address malfunction (inconsistency)

### 14.2 Symptoms that are NOT system malfunctions

The following symptoms are NOT system malfunctions:

#### 14.2.1 Symptom: The system does not operate

- The air conditioner does not start immediately after the ON/OFF button on the user interface is pressed. If the operation lamp lights, the system is in normal condition. To prevent overloading of the compressor motor, the air conditioner starts 5 minutes after it is turned ON again in case it was turned OFF just before. The same starting delay occurs after the operation mode selector button was used.
- If "Under Centralized Control" is displayed on the user interface, pressing the operation button causes the display to blink for a few seconds. The blinking display indicates that the user interface cannot be used.
- The system does not start immediately after the power supply is turned on. Wait one minute until the micro computer is prepared for operation.

#### 14.2.2 Symptom: Cool/Heat cannot be changed over

- When the display shows  (change-over under centralized control), it shows that this is a slave user interface.

- When the cool/heat changeover remote control switch is installed and the display shows  (change-over under centralized control), this is because cool/heat changeover is controlled by the cool/ heat changeover remote control switch. Ask your dealer where the remote control switch is installed.

#### 14.2.3 Symptom: Fan operation is possible, but cooling and heating do not work

Immediately after the power is turned on. The micro computer is getting ready to operate and is performing a communication check with all indoor units. Please wait 12 minutes (max.) till this process is finished.

#### 14.2.4 Symptom: The fan strength does not correspond to the setting

The fan speed does not change even if the fan speed adjustment button is pressed. During heating operation, when the room temperature reaches the set temperature, the outdoor unit goes off and the indoor unit changes to whisper fan speed. This is to prevent cold air blowing directly on occupants of the room. The fan speed will not change even when another indoor unit is in heating operation, if the button is pressed.

#### 14.2.5 Symptom: The fan direction does not correspond to the setting

The fan direction does not correspond with the user interface display. The fan direction does not swing. This is because the unit is being controlled by the micro computer.

#### 14.2.6 Symptom: White mist comes out of a unit (Indoor unit)

- When humidity is high during cooling operation. If the interior of an indoor unit is extremely contaminated, the temperature distribution inside a room becomes uneven. It is necessary to clean the interior of the indoor unit. Ask your dealer for details on cleaning the unit. This operation requires a qualified service person.
- Immediately after the cooling operation stops and if the room temperature and humidity are low. This is because warm refrigerant gas flows back into the indoor unit and generates steam.

#### 14.2.7 Symptom: White mist comes out of a unit (Indoor unit, outdoor unit)

When the system is changed over to heating operation after defrost operation. Moisture generated by defrost becomes steam and is exhausted.

#### 14.2.8 Symptom: The user interface display reads "U4" or "U5" and stops, but then restarts after a few minutes

This is because the user interface is intercepting noise from electric appliances other than the air conditioner. The noise prevents communication between the units, causing them to stop. Operation automatically restarts when the noise ceases.

#### 14.2.9 Symptom: Noise of air conditioners (Indoor unit)

- A "zeen" sound is heard immediately after the power supply is turned on. The electronic expansion valve inside an indoor unit starts working and makes the noise. Its volume will reduce in about one minute.

- A continuous low "shah" sound is heard when the system is in cooling operation or at a stop. When the drain pump (optional accessories) is in operation, this noise is heard.
- A "pishi-pishi" squeaking sound is heard when the system stops after heating operation. Expansion and contraction of plastic parts caused by temperature change make this noise.
- A low "sah", "choro-choro" sound is heard while the indoor unit is stopped. When another indoor unit is in operation, this noise is heard. In order to prevent oil and refrigerant from remaining in the system, a small amount of refrigerant is kept flowing.

#### **14.2.10 Symptom: Noise of air conditioners (Indoor unit, outdoor unit)**

- A continuous low hissing sound is heard when the system is in cooling or defrost operation. This is the sound of refrigerant gas flowing through both indoor and outdoor units.
- A hissing sound which is heard at the start or immediately after stopping operation or defrost operation. This is the noise of refrigerant caused by flow stop or flow change.

#### **14.2.11 Symptom: Noise of air conditioners (Outdoor unit)**

When the tone of operating noise changes. This noise is caused by the change of frequency.

#### **14.2.12 Symptom: Dust comes out of the unit**

When the unit is used for the first time in a long time. This is because dust has gotten into the unit.

#### **14.2.13 Symptom: The units can give off odours**

The unit can absorb the smell of rooms, furniture, cigarettes, etc., and then emit it again.

#### **14.2.14 Symptom: The outdoor unit fan does not spin**

During operation. The speed of the fan is controlled in order to optimise product operation.

#### **14.2.15 Symptom: The display shows "88"**

This is the case immediately after the main power supply switch is turned on and means that the user interface is in normal condition. This continues for 1 minute.

#### **14.2.16 Symptom: The compressor in the outdoor unit does not stop after a short heating operation**

This is to prevent refrigerant from remaining in the compressor. The unit will stop after 5 to 10 minutes.

#### **14.2.17 Symptom: The inside of an outdoor unit is warm even when the unit has stopped**

This is because the crankcase heater is warming the compressor so that the compressor can start smoothly.

#### **14.2.18 Symptom: Hot air can be felt when the indoor unit is stopped**

Several different indoor units are being run on the same system. When another unit is running, some refrigerant will still flow through the unit.

## **15 Relocation**

Contact your dealer for removing and reinstalling the total unit. Moving units requires technical expertise.

## **16 Disposal**

This unit uses hydrofluorocarbon. Contact your dealer when discarding this unit. It is required by law to collect, transport and discard the refrigerant in accordance with the "hydrofluorocarbon collection and destruction" regulations.

ERC



4P370473-1 D 0000000/

Copyright 2014 Daikin