



# Air Conditioning Technical Data

VRV IV heat pump, with continuous heating



EEDEN14-200\_1

RYYQ-T



# TABLE OF CONTENTS

## RYYQ-T

1	Features .....	2
2	Specifications .....	3
	Technical Specifications .....	3
	Electrical Specifications .....	4
	Technical Specifications .....	5
	Technical Specifications .....	6
	Electrical Specifications .....	7
	Electrical Specifications .....	7
	Technical Specifications .....	8
	Electrical Specifications .....	8
3	Options .....	10
4	Combination table .....	11
5	Capacity tables .....	14
	Capacity Table Legend .....	14
6	Dimensional drawings .....	15
7	Centre of gravity .....	16
8	Piping diagrams .....	17
9	Wiring diagrams .....	21
	Wiring Diagrams - Three Phase .....	21
10	External connection diagrams .....	25
11	Sound data .....	27
	Sound Power Spectrum .....	27
	Sound Pressure Spectrum .....	29
12	Installation .....	31
	Installation Method .....	31
	Fixation and Foundation of Units .....	32
	Refrigerant Pipe Selection .....	33
13	Operation range .....	40

# 1 Features

- Customize your VRV for best seasonal efficiency & comfort with the weather dependant Variable Refrigerant Temperature function
- Up to 28% higher seasonal efficiency with Variable Refrigerant Temperature when compared to previous series
- Best comfort, no cold draft by supply of a high outblow air temperature thanks to Variable Refrigerant Temperature and all inverter technology
- Continuous comfort: Unique continuous heating technology makes VRV IV the best alternative to traditional heating systems
- VRV configurator software for the fastest and most accurate commissioning, configuration and customisation
- Accurate temperature control, fresh air provision, air handling units, Biddle air curtains and hot water production, all integrated in a single system requiring only one single point of contact
- Outdoor unit display for quick on-site settings and easy read out of errors together with the indication of service parameters for checking basic functions.
- Free combination of outdoor units to meet installation space or efficiency requirements
- Fits any building as also indoor installation is possible as a result of high external static pressure of up to 78.4 Pa. Indoor installation leads to less piping length, lower installation costs, increased efficiency and better visual aesthetics
- Simplified installation & guaranteed optimal efficiency with automatic charging & testing
- Easy compliance with F-gas regulation thanks to automated refrigerant containment check
- Wide piping flexibility: 30m indoor height difference, maximum piping length: 190m, total piping length: 1,000m
- The ability to control each conditioned zone individually keeps VRV system running costs to an absolute minimum
- Spread your installation cost by phased installation
- Wide range of indoor units: possibility to combine VRV with stylish indoor units (Daikin Emura, Nexura, ...)
- Keep your system in top condition via our ACNSS service: 24/7 monitoring for maximum efficiency, extended lifetime, immediate service support thanks to failure prediction and a clear understanding of operability and usage
- Available as heating only by irreversible field setting



Inverter

## 2 Specifications

2-1 Technical Specifications				RYYQ8T	RYYQ10T	RYYQ12T	RYYQ14T	RYYQ16T	RYYQ18T	RYYQ20T	
Capacity range			HP	8	10	12	14	16	18	20	
Cooling capacity	Nom.		kW	22.4	28.0	33.5	40.0	45.0	50.0	56.0	
Heating capacity	Nom.		kW	22.4	28.0	33.5	40.0	45.0	50.0	56.0	
	Max.		kW	25.0	31.5	37.5	45.0	50.0	56.0	63.0	
Power input - 50Hz	Cooling	Nom.	kW	5.21	7.29	8.98	11.0	13.0	14.7	18.5	
	Heating	Nom.	kW	4.75	6.29	7.77	9.52	11.1	12.4	14.5	
		Max.	kW	5.51	7.38	9.10	11.2	12.8	14.4	17.0	
Capacity control	Method			Inverter controlled							
EER				4.30	3.84	3.73	3.64	3.46	3.40	3.03	
ESEER				6.37 / 7.53	5.67 / 7.20	5.50 / 6.96	5.31 / 6.83	5.05 / 6.50	4.97 / 6.38	4.42 / 5.67	
COP				4.72 / 4.54	4.45 / 4.27	4.31 / 4.12	4.20 / 4.02	4.05 / 3.91	4.03 / 3.89	3.86 / 3.71	
Maximum number of connectable indoor units				64							
Indoor index connection	Min.			100	125	150	175	200	225	250	
	Nom.			200	250	300	350	400	450	500	
	Max.			260	325	390	455	520	585	650	
Casing	Colour			Daikin White							
	Material			Painted galvanized steel plate							
Dimensions	Unit	Height	mm	1,685							
		Width	mm	930			1,240				
		Depth	mm	765							
	Packed unit	Height	mm	1,820							
		Width	mm	1,000			1,310				
		Depth	mm	835							
Weight	Unit		kg	261	268	364	398				
	Packed unit		kg	279	287	384	418				
Packing	Material			Carton							
	Weight		kg	2.00			3.00				
Packing 2	Material			Wood							
	Weight		kg	17.00			18.50				
Packing 3	Material			Plastic							
	Weight		kg	0.50							
Heat exchanger	Type			Cross fin coil							
	Fin	Treatment		Anti-corrosion treatment							
Compressor	Quantity			1			2				
	Model			Inverter							
	Type			Hermetically sealed scroll compressor							
	Crankcase heater		W	33							
Fan	Type			Propeller fan							
	Quantity			1			2				
	Air flow rate	Cooling	Nom.	m <sup>3</sup> /min	162	175	185	223	260	251	261
	External static pressure	Max.		Pa	78						
	Discharge direction			Vertical							
Fan motor	Quantity			1			2				
	Model			Brushless DC motor							
	Output		W	750							
Sound power level	Cooling	Nom.	dB(A)	78	79	81	86	88			
Sound pressure level	Cooling	Nom.	dB(A)	58			61	64	65	66	
Operation range	Cooling	Min.~Max.		°CDB	-5~43						
	Heating	Min.~Max.		°CWB	-20~15.5						
Refrigerant	Type			R-410A							
	Charge		kg	5.9	6	6.3	10.3	10.4	11.7	11.8	
Refrigerant oil	Type			Synthetic (ether) oil							
	Charged volume		l	0.8	0.5	0.7	1.8	1.7	1.9		

## 2 Specifications

2

2-1 Technical Specifications				RYYQ8T	RYYQ10T	RYYQ12T	RYYQ14T	RYYQ16T	RYYQ18T	RYYQ20T	
Piping connections	Liquid	Type		Braze connection							
		OD	mm	9.52			12.7		15.9		
	Gas	Type		Braze connection							
		OD	mm	19.1	22.2	28.6					
	Heat insulation				Both liquid and gas pipes						
	Piping length	OU - IU	Max.	m	165						
		After branch	Max.	m	90						
Total piping length	System	Actual	m	1,000							
Level difference	OU - IU	Outdoor unit in highest position	m	90							
		Indoor unit in highest position	m	90							
	IU - IU	Max.	m	30							
Defrost method				Reversed cycle							
Safety devices	Item	01	High pressure switch								
		02	Fan driver overload protector								
		03	Inverter overload protector								
		04	PC board fuse								
PED	Category			Category II							

Standard Accessories : Installation and operation manual;

Standard Accessories : Connection pipes;

2-2 Electrical Specifications				RYYQ8T	RYYQ10T	RYYQ12T	RYYQ14T	RYYQ16T	RYYQ18T	RYYQ20T
Power supply	Name			Y1						
	Phase			3N~						
	Frequency	Hz		50						
	Voltage	V		380-415						
Voltage range	Min.	%		-10						
	Max.	%		10						
Current	Nominal running current (RLA) - 50Hz	Cooling	A	7.2	10.2	12.7	15.4	18.0	20.8	26.9
Current - 50Hz	Minimum Ssc value		kVa	1,216	564	615	917	924	873	970
	Minimum circuit amps (MCA)		A	16.1	22.0	24.0	27.0	31.0	35.0	39.0
	Maximum fuse amps (MFA)		A	20	25	32		40		50
	Total overcurrent amps (TOCA)		A	17.3	24.6		35.4		42.7	
	Full load amps (FLA)	Total	A	1.2	1.3	1.5	1.8	2.6		
Wiring connections - 50Hz	For power supply	Quantity		5G						
	For connection with indoor	Quantity		2						
		Remark		F1,F2						
Power supply intake				Both indoor and outdoor unit						

### Notes

- (1) Cooling: indoor temp. 27°CDB, 19°CWB; outdoor temp. 35°CDB; equivalent piping length: 5m; level difference: 0m
- (2) heating: indoor temp. 20°CDB; outdoor temp. 7°CDB, 6°CWB; equivalent refrigerant piping: 5m; level difference: 0m (nominal)
- (3) Actual number of connectable indoor units depends on the indoor unit type (VRV indoor, Hydrobox, RA indoor, etc.) and the connection ratio restriction for the system (50%  $\leq$  CR  $\leq$  130%)
- (4) For more details on operation range see TW drawing
- (5) Voltage range: units are suitable for use on electrical systems where voltage supplied to unit terminal is not below or above listed range limits.
- (6) Maximum allowable voltage range variation between phases is 2%.
- (7) Refer to refrigerant pipe selection or installation manual
- (8) For more details on standard accessories refer to Installation/operation manual
- (9) RLA is based on following conditions: indoor temp. 27°CDB, 19°CWB; outdoor temp. 35°CDB
- (10) MSC means the maximum current during start up of the compressor. VRV IV uses only inverter compressors. Starting current is always  $\leq$  max. running current.

## 2 Specifications

- (11) Select wire size based on the value of MCA. The MCA can be regarded as the maximum running current.
- (12) MFA is used to select the circuit breaker and the ground fault circuit interrupter (earth leakage circuit breaker).
- (13) TOCA means the total value of each OC set.
- (14) FLA means the nominal running current of the fan
- (15) In accordance with EN/IEC 61000-3-11, respectively EN/IEC 61000-3-12, it may be necessary to consult the distribution network operator to ensure that the equipment is connected only to a supply with  $Z_{sys} \leq Z_{max}$ , respectively  $S_{sc} \geq$  minimum  $S_{sc}$  value.
- (16) European/International Technical Standard setting the limits for voltage changes, voltage fluctuations and flicker in public low-voltage supply systems for equipment with rated current  $\leq 75A$ .
- (17) European/International Technical Standard setting the limits for harmonic currents produced by equipment connected to public low-voltage systems with input current  $\leq 16A$  and  $\leq 75A$  per phase
- (18) Short-circuit power
- (19) system impedance
- (20) Multi combination (22~54HP) data is corresponding with the standard multi combination as mentioned on 3D079534
- (21) Sound power level is an absolute value that a sound source generates.
- (22) Sound pressure level is a relative value, depending on the distance and acoustic environment. For more details, please refer to the sound level drawings.
- (23) Sound values are measured in a semi-anechoic room.
- (24) The STANDARD ESEER value corresponds with normal VRV4 Heat Pump operation, not taking into account advanced energy saving operation functionality
- (25) The AUTOMATIC SEER value corresponds with normal VRV4 Heat Pump operation, taking into account advanced energy saving operation functionality ( variable refrigerant temperature control operation)
- (26) heating: indoor temp. 20°CDB; outdoor temp. 7°CDB, 6°CWB; equivalent refrigerant piping: 5m; level difference: 0m (maximum)
- (27) Cooling: indoor temp. 27°CDB, 19.0°CWB; outdoor temp. 35°CDB; equivalent piping length: 5m; level difference: 0m
- (28) Sound values are theoretical values based on sound results of individual installed units. Possible deviations due to variety of installation patterns are not taken into account.
- (29) Soundpressure system [dBA] =  $10 \cdot \log[10^{A/10} + 10^{B/10} + 10^{C/10}]$ , with Unit A = A dBA, Unit B = B dBA, Unit C = C dBA
- (30) Cooling: indoor temp. 27°CDB, 19°CWB; outdoor temp. 35°CDB; equivalent piping length: 5m (horizontal); level difference: 0m
- (31) Heating: indoor temp. 20°CDB; outdoor temp. 7°CDB, 6°CWB; equivalent refrigerant piping: 5m; level difference: 0m

2-3 Technical Specifications			RYYQ22 T	RYYQ24 T	RYYQ26 T	RYYQ28 T	RYYQ30 T	RYYQ32 T	RYYQ34 T	RYYQ36 T	RYYQ38 T	RYYQ40 T	
System	Outdoor unit module 1		RYMQ1 0T	RYMQ8 T	RYMQ12T			RYMQ16T			RYMQ8 T	RYMQ1 0T	
	Outdoor unit module 2		RYMQ1 2T	RYMQ1 6T	RYMQ1 4T	RYMQ1 6T	RYMQ1 8T	RYMQ1 6T	RXYQ1 8T	RYMQ2 0T	RYMQ1 0T	RYMQ1 2T	
	Outdoor unit module 3		-								RYMQ2 0T	RYMQ1 8T	
Capacity range			HP	22	24	26	28	30	32	34	36	38	40
Cooling capacity	Nom.		kW	61.5	67.4	73.5	78.5	83.5	90.0	95.0	101.0	106.0	111.5
Heating capacity	Nom.		kW	61.5	67.4	73.5	78.5	83.5	90.0	95.0	101.0	106.4	111.5
	Max.		kW	69.0	75.0	82.5	87.5	93.5	100.0	106.0	113.0	119.5	125.0
Power input - 50Hz	Cooling	Nom.	kW	16.27	18.2	20.0	22.0	23.7	26.0	27.7	31.5	31.0	
		Heating	Nom.	kW	14.06	15.85	17.29	18.87	20.17	22.2	23.5	25.6	25.54
		Max.	kW	16.48	18.31	20.30	21.90	23.50	25.6	27.2	29.8	29.89	30.88
EER				3.77	3.70	3.68	3.57	3.52	3.46	3.43	3.21	3.42	3.61
ESEER				5.58 / 7.07	5.42 / 6.81	5.39 / 6.89	5.23 / 6.69	5.17 / 6.60	5.05 / 6.50	5.01 / 6.44	4.68 / 6.02	5.03 / 6.36	5.29 / 6.74
COP				4.37 / 4.19	4.25 / 4.10	4.25 / 4.06	4.16 / 4.00	4.14 / 3.98	4.05 / 3.91	4.04 / 3.90	3.95 / 3.79	4.17 / 4.00	4.21 / 4.05
Maximum number of connectable indoor units				64									
Indoor index connection	Min.			275	300	325	350	375	400	425	450	475	500
	Nom.			550	600	650	700	750	800	850	900	950	1,000
	Max.			715	780	845	910	975	1,040	1,105	1,170	1,235	1,300

## 2 Specifications

2

2-3 Technical Specifications				RYYQ22 T	RYYQ24 T	RYYQ26 T	RYYQ28 T	RYYQ30 T	RYYQ32 T	RYYQ34 T	RYYQ36 T	RYYQ38 T	RYYQ40 T	
Piping connections	Liquid	OD	mm	15.9		19.1								
	Gas	OD	mm	28.6	34.9						41.3			
	Piping length	OU - IU	Max.	m	165									
		After branch	Max.	m	90									
	Total piping length	System	Actual	m	1,000									
	Level difference	OU - IU	Outdoor unit in highest position	m	90									
Indoor unit in highest position			m	90										
IU - IU		Max.	m	30										
PED	Category			Category II										

Standard Accessories : Installation and operation manual;

Standard Accessories : Connection pipes;

2-4 Technical Specifications				RYYQ42T	RYYQ44T	RYYQ46T	RYYQ48T	RYYQ50T	RYYQ52T	RYYQ54T		
System	Outdoor unit module 1			RYMQ10T	RYMQ12T	RYMQ14T	RYMQ16T			RYMQ18T		
	Outdoor unit module 2			RYMQ16T				RYMQ18T				
	Outdoor unit module 3			RYMQ16T				RYMQ18T				
Capacity range	HP			42	44	46	48	50	52	54		
Cooling capacity	Nom.	kW			118.0	123.5	130.0	135.0	140.0	145.0	150.0	
Heating capacity	Nom.	kW			118.0	123.5	130.0	135.0	140.0	145.0	150.0	
	Max.	kW			131.5	137.5	145.0	150.0	156.0	162.0	168.0	
Power input - 50Hz	Cooling	Nom.	kW			33.3	35.0	37.0	39.0	40.7	42.4	44.1
		Heating	Nom.	kW			28.49	29.97	31.72	33.3	34.6	35.9
	Max.	kW			32.98	34.70	36.8	38.4	40.0	41.6	43.2	
EER				3.54		3.51	3.46	3.44	3.42	3.40		
ESEER				5.19 / 6.65	5.17 / 6.62	5.13 / 6.60	5.05 / 6.50	5.02 / 6.46	4.99 / 6.42	4.97 / 6.38		
COP				4.14 / 3.99	4.12 / 3.96	4.10 / 3.94	4.05 / 3.91	4.05 / 3.90	4.04 / 3.89	4.03 / 3.89		
Maximum number of connectable indoor units				64								
Indoor index connection	Min.			525	550	575	600	625	650	675		
	Nom.			1,050	1,100	1,150	1,200	1,250	1,300	1,350		
	Max.			1,365	1,430	1,495	1,560	1,625	1,690	1,755		
Piping connections	Liquid	OD	mm	19.1								
	Gas	OD	mm	41.3								
	Piping length	OU - IU	Max.	m	165							
		After branch	Max.	m	90							
	Total piping length	System	Actual	m	1,000							
	Level difference	OU - IU	Outdoor unit in highest position	m	90							
Indoor unit in highest position			m	90								
IU - IU		Max.	m	30								
PED	Category			Category II								

Standard Accessories : Installation and operation manual;

Standard Accessories : Connection pipes;



## 2 Specifications

2-5 Electrical Specifications				RYYQ22 T	RYYQ24 T	RYYQ26 T	RYYQ28 T	RYYQ30 T	RYYQ32 T	RYYQ34 T	RYYQ36 T	RYYQ38 T	RYYQ40 T
Current	Nominal running current (RLA) - 50Hz	Cooling	A	22.9	25.2	28.1	30.7	33.5	36.0	38.8	44.9	44.3	43.7
Current - 50Hz	Minimum Ssc value	kVa		1,179	2,140	1,532	1,539	1,488	1,848	1,797	1,894	2,750	2,052
	Minimum circuit amps (MCA)	A		46.0		51.0	55.0	59.0	62.0	66.0	70.0	76.0	81.0
	Maximum fuse amps (MFA)	A		63				80			100		
Wiring connections - 50Hz	For power supply	Quantity		5G									
	For connection with indoor	Quantity		2									
		Remark		F1,F2									
Power supply intake	Both indoor and outdoor unit												

2-6 Electrical Specifications				RYYQ42T	RYYQ44T	RYYQ46T	RYYQ48T	RYYQ50T	RYYQ52T	RYYQ54T
Current	Nominal running current (RLA) - 50Hz	Cooling	A	46.2	48.7	51.4	54.0	56.8	59.6	62.4
Current - 50Hz	Minimum Ssc value	kVa		2,412	2,463	2,765	2,772	2,721	2,670	2,619
	Minimum circuit amps (MCA)	A		84.0	86.0	89.0	93.0	97.0	101.0	105.0
	Maximum fuse amps (MFA)	A		100			125			
Wiring connections - 50Hz	For power supply	Quantity		5G						
	For connection with indoor	Quantity		2						
		Remark		F1,F2						
Power supply intake	Both indoor and outdoor unit									

### Notes

- (1) Cooling: indoor temp. 27°CDB, 19°CWB; outdoor temp. 35°CDB; equivalent piping length: 5m; level difference: 0m
- (2) heating: indoor temp. 20°CDB; outdoor temp. 7°CDB, 6°CWB; equivalent refrigerant piping: 5m; level difference: 0m (nominal)
- (3) Actual number of connectable indoor units depends on the indoor unit type (VRV indoor, Hydrobox, RA indoor, etc.) and the connection ratio restriction for the system (50% ≤ CR ≤ 130%)
- (4) For more details on operation range see TW drawing
- (5) Voltage range: units are suitable for use on electrical systems where voltage supplied to unit terminal is not below or above listed range limits.
- (6) Maximum allowable voltage range variation between phases is 2%.
- (7) Refer to refrigerant pipe selection or installation manual
- (8) For more details on standard accessories refer to Installation/operation manual
- (9) RLA is based on following conditions: indoor temp. 27°CDB, 19°CWB; outdoor temp. 35°CDB
- (10) MSC means the maximum current during start up of the compressor. VRV IV uses only inverter compressors. Starting current is always ≤ max. running current.
- (11) Select wire size based on the value of MCA. The MCA can be regarded as the maximum running current.
- (12) MFA is used to select the circuit breaker and the ground fault circuit interrupter (earth leakage circuit breaker).
- (13) TOCA means the total value of each OC set.
- (14) FLA means the nominal running current of the fan
- (15) In accordance with EN/IEC 61000-3-11, respectively EN/IEC 61000-3-12, it may be necessary to consult the distribution network operator to ensure that the equipment is connected only to a supply with  $Z_{sys} \leq Z_{max}$ , respectively  $S_{sc} \geq$  minimum Ssc value.
- (16) European/International Technical Standard setting the limits for voltage changes, voltage fluctuations and flicker in public low-voltage supply systems for equipment with rated current ≤ 75A.
- (17) European/International Technical Standard setting the limits for harmonic currents produced by equipment connected to public low-voltage systems with input current >16A and ≤ 75A per phase
- (18) Short-circuit power
- (19) system impedance
- (20) Multi combination (22~54HP) data is corresponding with the standard multi combination as mentioned on 3D079534
- (21) Sound power level is an absolute value that a sound source generates.
- (22) Sound pressure level is a relative value, depending on the distance and acoustic environment. For more details, please refer to the sound level drawings.
- (23) Sound values are measured in a semi-anechoic room.
- (24) The STANDARD ESEER value corresponds with normal VRV4 Heat Pump operation, not taking into account advanced energy saving operation functionality
- (25) The AUTOMATIC SEER value corresponds with normal VRV4 Heat Pump operation, taking into account advanced energy saving operation functionality ( variable refrigerant temperature control operation)
- (26) heating: indoor temp. 20°CDB; outdoor temp. 7°CDB, 6°CWB; equivalent refrigerant piping: 5m; level difference: 0m (maximum)
- (27) Cooling: indoor temp. 27°CDB, 19.0°CWB; outdoor temp. 35°CDB; equivalent piping length: 5m; level difference: 0m
- (28) Sound values are theoretical values based on sound results of individual installed units. Possible deviations due to variety of installation patterns are not taken into account.
- (29) Soundpressure system [dBA] =  $10 \cdot \log[10^{A/10} + 10^{B/10} + 10^{C/10}]$ , with Unit A = A dBA, Unit B = B dBA, Unit C = C dBA
- (30) Cooling: indoor temp. 27°CDB, 19°CWB; outdoor temp. 35°CDB; equivalent piping length: 5m (horizontal); level difference: 0m
- (31) Heating: indoor temp. 20°CDB; outdoor temp. 7°CDB, 6°CWB; equivalent refrigerant piping: 5m; level difference: 0m

## 2 Specifications

2

2-7 Technical Specifications				RYMQ8T	RYMQ10T	RYMQ12T	RYMQ14T	RYMQ16T	RYMQ18T	RYMQ20T	
Casing	Colour			Daikin White							
	Material			Painted galvanized steel plate							
Dimensions	Unit	Height	mm	1,685							
		Width	mm	930			1,240				
		Depth	mm	765							
	Packed unit	Height	mm	1,820							
		Width	mm	1,000			1,310				
		Depth	mm	835							
Weight	Unit		kg	188	195	309	319				
	Packed unit		kg	206	213	329	339				
Packing	Material			Carton							
	Weight			kg	2.00			3.00			
Packing 2	Material			Wood							
	Weight			kg	17.00			18.50			
Packing 3	Material			Plastic							
	Weight			kg	0.50	0	0.50				
Heat exchanger	Type			Cross fin coil							
	Fin	Treatment		Anti-corrosion treatment							
Compressor	Quantity			1			2				
	Model			Inverter							
	Type			Hermetically sealed scroll compressor							
	Crankcase heater		W	33							
Fan	Type			Propeller fan							
	Quantity			1			2				
	Air flow rate	Cooling	Nom.	m <sup>3</sup> /min	162	175	185	223	260	251	261
	External static pressure	Max.		Pa	78						
	Discharge direction			Vertical							
Fan motor	Quantity			1			2				
	Model			Brushless DC motor							
	Output		W	750							
Sound power level	Cooling	Nom.	dBA	78	79	81	86		88		
Sound pressure level	Cooling	Nom.	dBA	58			61	64	65	66	
Operation range	Cooling	Min.~Max.	°CDB	-5~43							
	Heating	Min.~Max.	°CWB	-20~15.5							
Refrigerant	Type			R-410A							
	Charge			kg	5.9	6	6.3	10.3	10.4	11.7	11.8
Refrigerant oil	Type			Synthetic (ether) oil							
	Charged volume			l	1.0	1.2	1.4	2.4	3.3		
Piping connections	Heat insulation			Liquid, gas and equalizing pipe							
Safety devices	Item	01	High pressure switch								
		02	Fan driver overload protector								
		03	Inverter overload protector								
		04	PC board fuse								

2-8 Electrical Specifications				RYMQ8T	RYMQ10T	RYMQ12T	RYMQ14T	RYMQ16T	RYMQ18T	RYMQ20T	
Power supply	Name			Y1							
	Phase			3N~							
	Frequency			Hz	50						
	Voltage			V	380-415						
Voltage range	Min.			%	-10						
	Max.			%	10						
Current	Nominal running current (RLA) - 50Hz	Cooling	A	7.2	10.2	12.7	15.4	18.0	20.8	26.9	

## 2 Specifications

2-8 Electrical Specifications			RYMQ8T	RYMQ10T	RYMQ12T	RYMQ14T	RYMQ16T	RYMQ18T	RYMQ20T
Current - 50Hz	Minimum circuit amps (MCA)	A	16.1	22.0	24.0	27.0	31.0	35.0	39.0
	Maximum fuse amps (MFA)	A	20	25	32		40		50
	Total overcurrent amps (TOCA)	A	17.3	24.6		35.4		42.7	
	Full load amps (FLA)	Total	A	1.2	1.3	1.5	1.8	2.6	
Notes			Sound values are measured in a semi-anechoic room.						

# 3 Options

## 3 - 1 Options

3

RYYQ-T  
RYMQ-T  
RXYQ-T

No.	Item.	RYYQ8T RXYQ8T		RYYQ10-12T RXYQ10-12T		RYYQ14-18T RXYQ14-18T		RYYQ20-54T RXYQ20-54T	
I.	Refnet heater	KHRQ22M29H							
		---							
		KHRQ22M64H							
II.	Refnet Joint	KHRQ22M20T							
		KHRQ22M29T9							
		---							
		KHRQ22M64T							
III.	Outdoor multi connection kit (see note 2)	---		---		---		KHRQ22M75T	
IV.	Outdoor multi connection kit (see note 2)	---		---		---		BHFQ22P1007	
<b>No.</b>	<b>Item.</b>	<b>8HP</b>	<b>10HP</b>	<b>12HP</b>	<b>14HP</b>	<b>16HP</b>	<b>18HP</b>	<b>20HP</b>	
1a	Cool/heat selector (switch)	KRC19-26A							
1b	Cool/heat selector (PCB)	BRP2A81							
1c	Cool/heat selector (sWB mounting plate)	---				KKS A26A560*			
1d	Cool/heat selector (fixing box)	KJB111A							
2	VRV configurator	EKPCAB*							
3	Heater tape kit (see note 6)	EKBP H012T*				EKBP H020T*			
4	Heater tape kit PCB	EKBP HPCBT*							
5	Demand PCB (see note 7)	DTA104A61/62*							
6	Demand PCB (mounting plate)	---				KKS B26B1*			

### NOTES

1. All options are kits
2. Only for multi units
3. Option **1a** and **1b** are both required to operate the COOL/HEAT SELECTOR function on a VRV4 Heat Pump system
4. Option **1d** is required to mount **1a**
5. **1c** is only required when combining **1b** with **3** on a VRV4 Heat Pump system
6. To install the HEATER TAPE KIT, a HEATER TAPE KIT PCB is required
7. To install the DEMAND PCB on the Large casing type, the DEMAND PCB (MOUNTING PLATE) is required

Medium casing type VRV4 Heat Pump: modules 8~12HP

Large casing type VRV4 Heat Pump: modules 14~20HP

3D079531E

# 4 Combination table

## 4 - 1 Combination Table

RYYQ-T RYMQ-T		→ See <b>Notes</b> concerning base model type						
		8HP	10HP	12HP	14HP	16HP	18HP	20HP
Heat PUMP	RYYQ8*	1						
	RYYQ10*		1					
	RYYQ12*			1				
	RYYQ14*				1			
	RYYQ16*					1		
	RYYQ18*						1	
	RYYQ20*							1
Multi combination with 2 outdoor units	RYYQ22*		1	1				
	RYYQ24*	1				1		
	RYYQ26*			1	1			
	RYYQ28*			1		1		
	RYYQ30*			1			1	
	RYYQ32*					2		
	RYYQ34*					1	1	
	RYYQ36*					1		1
Multi combination with 3 outdoor units	RYYQ38*	1	1					1
	RYYQ40*		1	1			1	
	RYYQ42*		1			2		
	RYYQ44*			1		2		
	RYYQ46*				1	2		
	RYYQ48*					3		
	RYYQ50*					2	1	
	RYYQ52*					1	2	
	RYYQ54*						3	

### NOTES

RYYQ8~20\* = single non-continuous heating model

RYYQ22~54\* = multi non-continuous heating model

- Single unit can be chosen: RYYQ\* model (continuous heating) and RXYQ\* model (non-continuous heating)
- Multi combinations "non-continuous heating" consist out of RXYQ8~20 modules. Eg RXYQ36\* = RXYQ16\* + RXYQ20\*
- Multi combinations "continuous heating" consist out of RYMQ8~20 modules. Eg RYYQ36\* = RYMQ16\* + RYMQ20\*  
→ multi models RYMQ\* cannot be used as stand alone units (RYMQ8~20HP)
- Multi combinations can never contain RYYQ8-20 models
- Multi "continuous heating" RYYQ\* combinations can never contain RXYQ\* models
- Multi "non-continuous heating" RXYQ\* combinations can never contain RYMQ\* models

3D079534A

### RYYQ-T RYMQ-T RXYQ-T

Indoor unit combination pattern	VRV* DX indoor	RA DX indoor	Hydrobox	AHU <sup>(3)</sup>
VRV* DX indoor	0	0	0	0
RA DX indoor	0	0	x	x
Hydrobox	0	x	0 <sub>1</sub>	x
AHU <sup>(3)</sup>	0	x	x	0 <sub>2</sub>

0: allowed  
x: forbidden

### NOTES

#### 1) VRV\* DX indoor

- VRV DX indoor can only be allowed with one of the other combinable indoor units.

eg

Allowed: (VRV DX indoor + Hydro) **OR** (VRV DX indoor + RA DX indoor) **OR** (VRV DX indoor + AHU)

Not allowed: [VRV DX indoor + (RA DX indoor & (Hydro or AHU))] **OR** [VRV DX indoor + (Hydro & (RA DX indoor or AHU))]

#### 2) 0<sub>1</sub>

- Connecting only Hydroboxes without a VRV DX indoor unit to a VRV IV Heat Pump unit is not allowed

→ See also connection ratio (CR) restrictions (3D079540)

→ Only Hydrobox connection: cf Daikin Altherma solutions

- Only compatible Hydrobox is HXY\* series Hydrobox

→ HXHD\* Hydrobox is not allowed

#### 3) 0<sub>2</sub>:

AHU connection only (combination with VRV DX indoor units is not allowed; max. 30HP = 3 x "250" class EKEXV kit)

→ X-control is possible (up to 3 x [EKEXV+EKEQF\*box] are allowed to one outdoor unit (system)); no Variable Refrigerant Temperature control possible

→ Y-control is possible (up to 3 x [EKEXV+EKEQF\*box] are allowed to one outdoor unit (system)); no Variable Refrigerant Temperature control possible

#### 4) Combination of AHU with Hydrobox or RA DX indoor units is not allowed

#### 5) (3) Following are considered as "AHU"

→ EKEXV + EKEQ(M/F) + AHU coil

→ Biddle aircurtains

→ FXMQ\_MF units

#### Information

- VKM is considered to be a regular VRV DX indoor unit

3D079543D(1/2)

# 4 Combination table

## 4 - 1 Combination Table

4

RYYQ-T  
RYYM-T  
RXYQ-T

Indoor/Outdoor combination	RYYQ* (single CH)	RYYQ* (multi CH)	RXYQ* (single n-CH)	RXYQ* (multi n-CH)
VRV* DX indoor	0	0	0	0
RA DX indoor	0	x	0	x
Hydrobox (HXY*)	0	0 <sub>1</sub>	0	0 <sub>1</sub>
AHU <sup>(2)</sup>	0	0	0	0

0: allowed  
x: forbidden

### NOTES

1) 0<sub>1</sub>

Upon request through SPN procedure

1) <sup>(2)</sup> Following are considered as "AHU"

- EKEXV + EKEQ(M/F) + AHU coil
- Biddle aircurtains
- FXMQ\_MF units

3D079543D(2/2)

RYYQ-T  
RYYM-T  
RXYQ-T

VRV4 Heat Pump RA DX indoor unit compatibility list

Configuration		Unit type
Wall mounted	<i>Emura</i>	FTXG25J FTXG35J FTXG50J
		FTXS20K FTXS25K FTXS35K FTXS42K FTXS50K FTXS60G FTXS71G CTXS15K CTXS35K
Floor/Ceiling	<i>Flex</i>	FLXS25B FLXS35B FLXS50B FLXS60B
Floor standing	<i>FVXS</i>	FVXS25F FVXS35F FVXS50F
	<i>Nexura</i>	FVXG25K FVXG35K FVXG50K

### NOTES

1. Limitations on use of RA DX indoor units with VRV4 Heat Pump is subject to rules mentioned in 3D079543 and 3D079540.
2. Use VRV DX indoor equivalent in case RA/SA DX Cassette, Ceiling mounted or Duct type is needed.

3D082373

## 4 Combination table

### 4 - 1 Combination Table

RYYQ8-20T

VRV4 Heat Pump RA DX indoor unit compatibility list

Configuration		Unit type
Wall mounted	<i>Emura</i>	FTXG25J FTXG35J FTXG50J
		FTXS20K FTXS25K FTXS35K FTXS42K FTXS50K FTXS60G FTXS71G
Floor/Ceiling	<i>Flex</i>	CTXS15K CTXS35K
		FLXS25B FLXS35B FLXS50B FLXS60B
Floor standing	<i>FVXS</i>	FVXS25F FVXS35F FVXS50F
	<i>Nexura</i>	FVXG25K FVXG35K FVXG50K

#### NOTES

1. Limitations on use of RA DX indoor units with VRV4 Heat Pump is subject to rules mentioned in 3D079543 and 3D079540.
2. Use VRV DX indoor equivalent in case RA/SA DX Cassette, Ceiling mounted or Duct type is needed.

3D082373

## 5 Capacity tables

### 5 - 1 Capacity Table Legend

In order to fulfill more your requirements on quick access of data in the format you require, we have developed a tool to consult capacity tables.

Below you can find the link to the capacity table database and an overview of all the tools we have to help you select the correct product:

- Capacity table database: lets you find back and export quickly the capacity information you are looking for based upon unit model, refrigerant temperature and connection ratio.

→ <http://extranet.daikineurope.com/captab>

- E-data app: gives a complete overview of the Daikin products available in your country, with all engineering data and commercial info in your own language. Download the app now!

→ <https://itunes.apple.com/us/app/daikin-e-data/id565955746?mt=8>



- Selection software: allows you to do load calculations, equipment selections and energy simulations for our VRV, Daikin Altherma, refrigeration and applied systems products.

→ <http://extranet.daikineurope.com/en/software/downloads/default.jsp>



# 6 Dimensional drawings

## 6 - 1 Dimensional Drawings

**RYYQ8-12T**  
**RYMQ8-12T**

MODEL	AA	AB	AC
RYYQ8T	248	-	-
RYYQ10-12T	195	-	-
RYMQ8T	248	208	240
RYMQ10-12T	195	208	240

2D079532

No.	Parts name	Remarks
1	Liquid pipe connection port	See note 3
2	Gas pipe connection port	See note 3
3	Equalizing pipe connection port	See note 3
4	Power cord routing hole (side)	ø 65
5	Power cord routing hole (front)	ø 80
6	Power cord routing hole (front)	ø 65
7	Power cord routing hole (front)	ø 27
8	Power cord hole (bottom)	ø 65
9	Pipe routing hole (front)	
10	Pipe routing hole (bottom)	
11	Grounding terminal	Inside of switch box (M8)

**NOTES**

- Detail A and detail B indicate the dimensions after fixing the attached piping.
- Items 4 to 10: knock out hole.
- Gas pipe:  
 Ø 19.1 brazing connection: RYYQ8T, RYMQ8T  
 Ø 22.2 brazing connection: RYYQ10T, RYMQ10T  
 Ø 28.6 brazing connection: RYYQ12T, RYMQ12T  
 Liquid pipe:  
 Ø 9.5 brazing connection: RYYQ8-10T, RYMQ8-10T  
 Ø 12.7 brazing connection: RYYQ12T, RYMQ12T  
 Equalizing pipe:  
 Ø 19.1 brazing connection: RYM8-10T  
 Ø 22.2 brazing connection: RYM12T

**RYYQ14-20T**  
**RYMQ14-20T**

MODEL	AA	AB
RYYQ14-16T, RYMQ14-16T	240	205
RYYQ18-20T, RYMQ18-20T	240	210

2D079533

No.	Parts name	Remarks
1	Liquid pipe connection port	See note 3
2	Gas pipe connection port	See note 3
3	Equalizing pipe connection port	See note 3
4	Power cord routing hole (side)	ø 65
5	Power cord routing hole (front)	ø 80
6	Power cord routing hole (front)	ø 65
7	Power cord routing hole (front)	ø 27
8	Power cord hole (bottom)	ø 65
9	Pipe routing hole (front)	
10	Pipe routing hole (bottom)	
11	Grounding terminal	Inside of switch box (M8)

**NOTES**

- Detail A and detail B indicate the dimensions after fixing the attached piping.
- Items 4 to 10: knock out hole.
- Gas pipe:  
 Ø 28.6 brazing connection: RYYQ14-20T, RYMQ14-20T  
 Liquid pipe:  
 Ø 12.7 brazing connection: RYYQ14-15T, RYMQ14-15T  
 Ø 15.9 brazing connection: RYYQ18-20T, RYMQ18-20T  
 Equalizing pipe:  
 Ø 22.2 brazing connection: RYM14-16T  
 Ø 28.6 brazing connection: RYM18-20T

# 7 Centre of gravity

## 7 - 1 Centre of Gravity

7

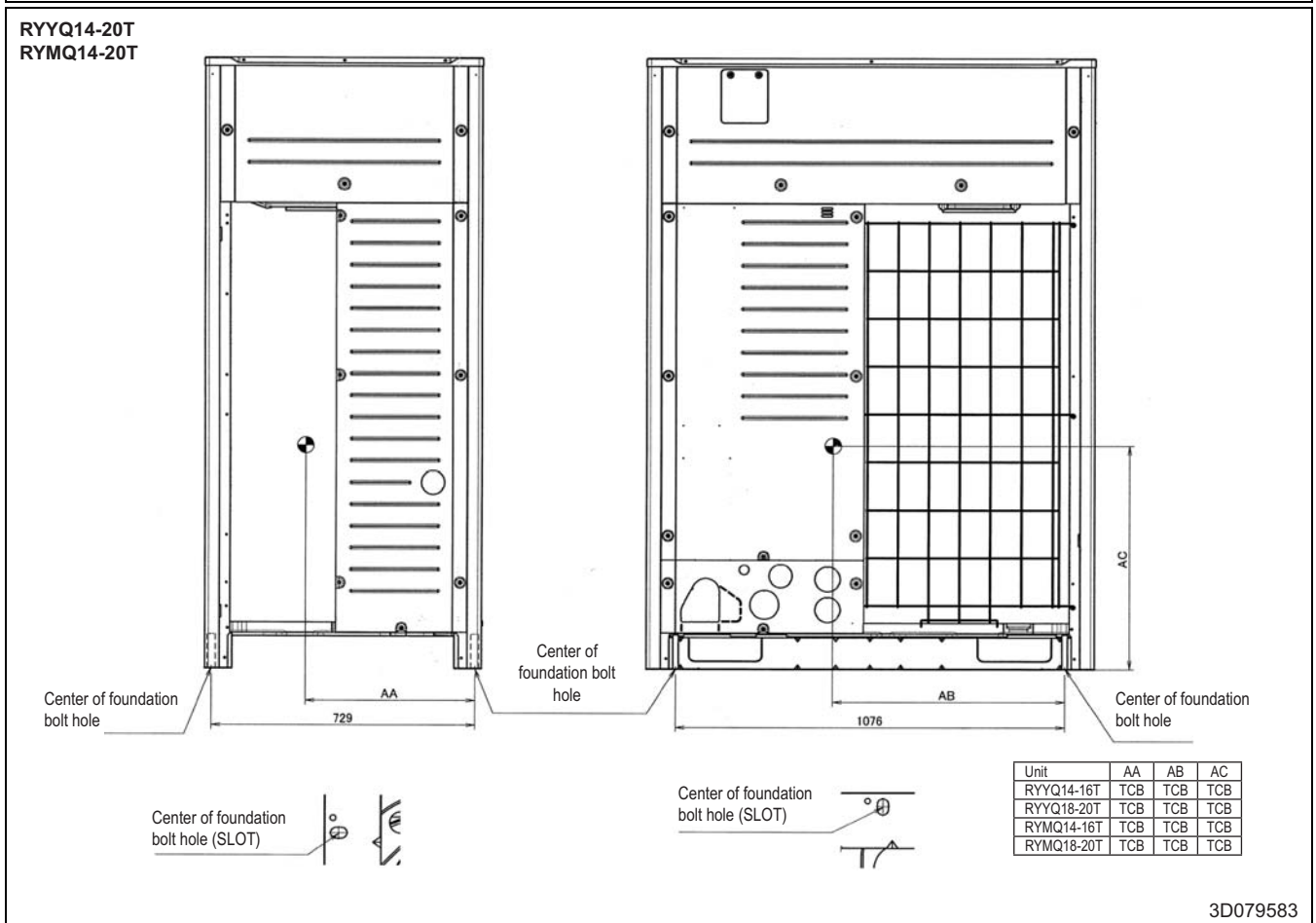
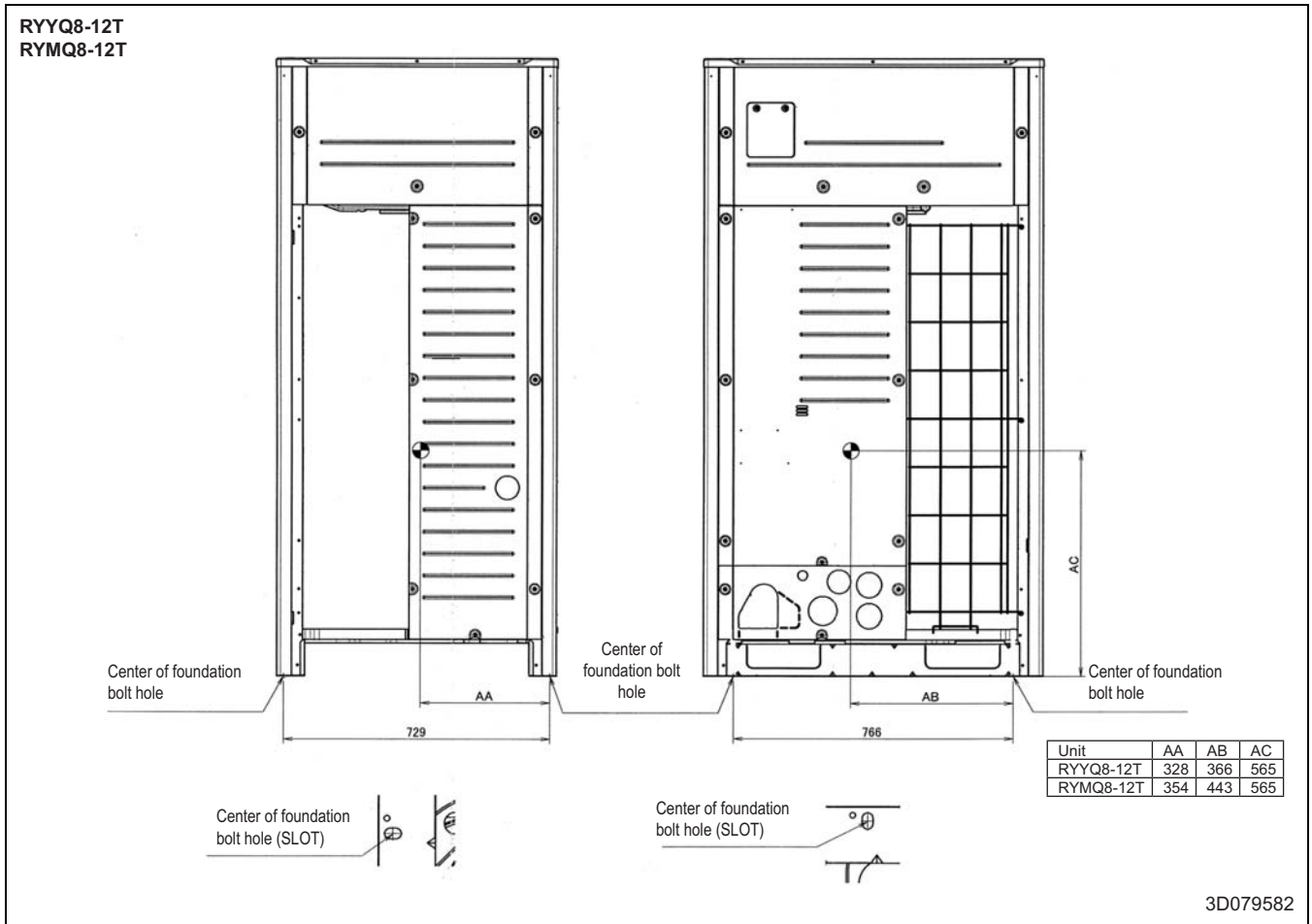

# 8 Piping diagrams

## 8 - 1 Piping Diagrams

RYMQ8-12T

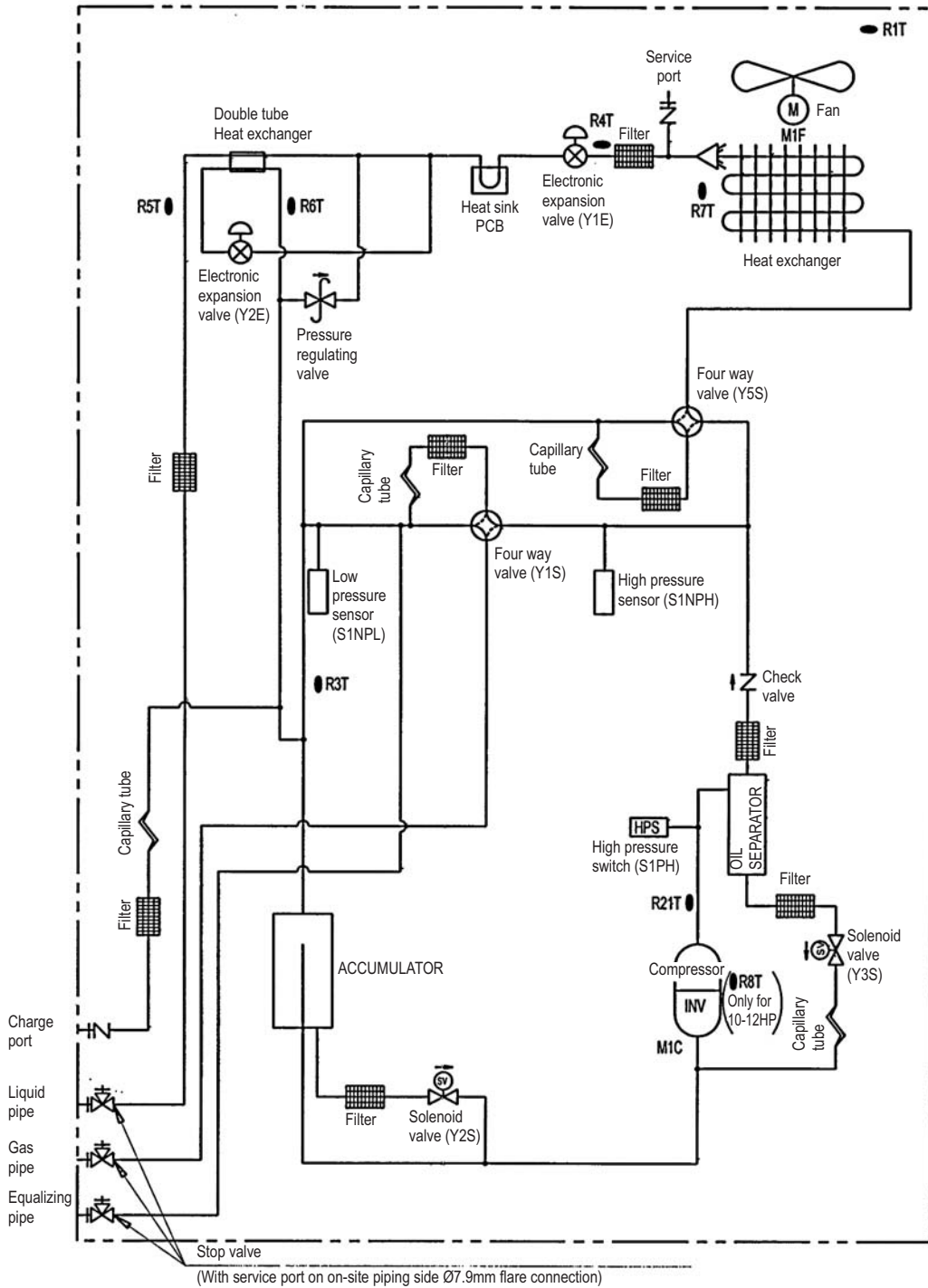

3D079554

# 8 Piping diagrams

## 8 - 1 Piping Diagrams

8

RYMQ14-20T

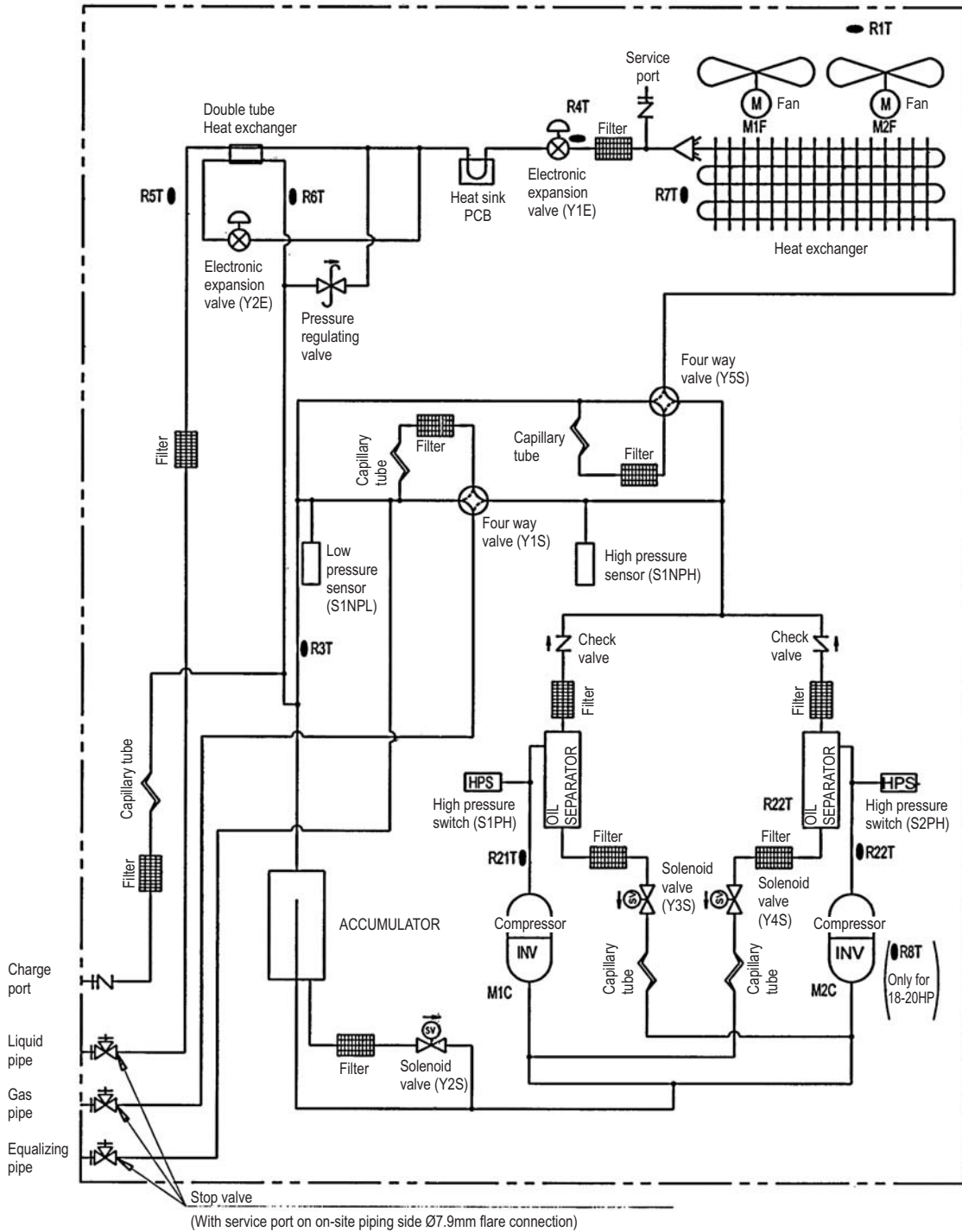

3D079555

# 8 Piping diagrams

## 8 - 1 Piping Diagrams

RYYQ8-12T

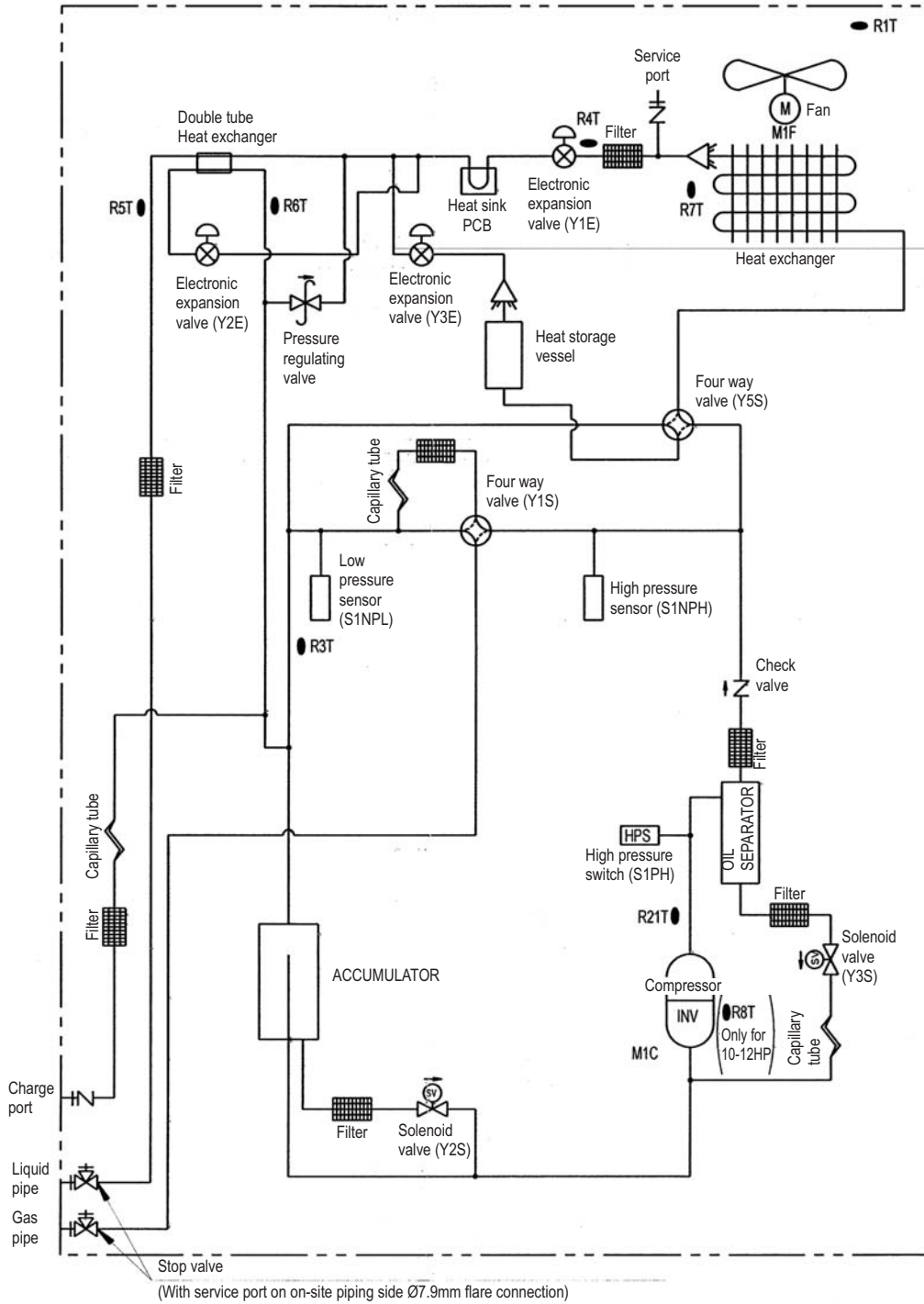

3D079552

# 8 Piping diagrams

## 8 - 1 Piping Diagrams

8

RYYQ14-20T

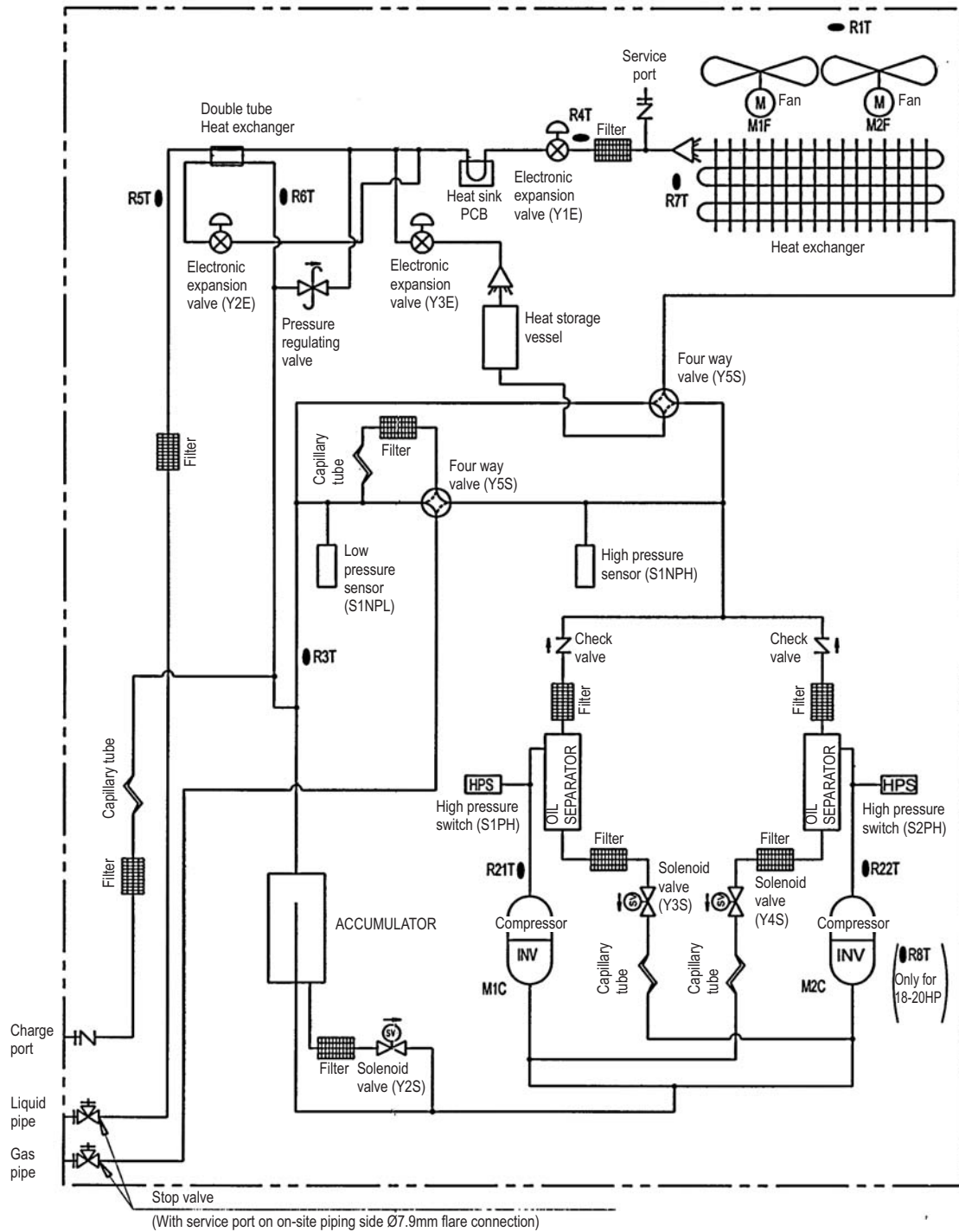

3D079553



# 9 Wiring diagrams

## 9 - 1 Wiring Diagrams - Three Phase

RYYQ8T  
RYMQ8T  
RXYQ8T

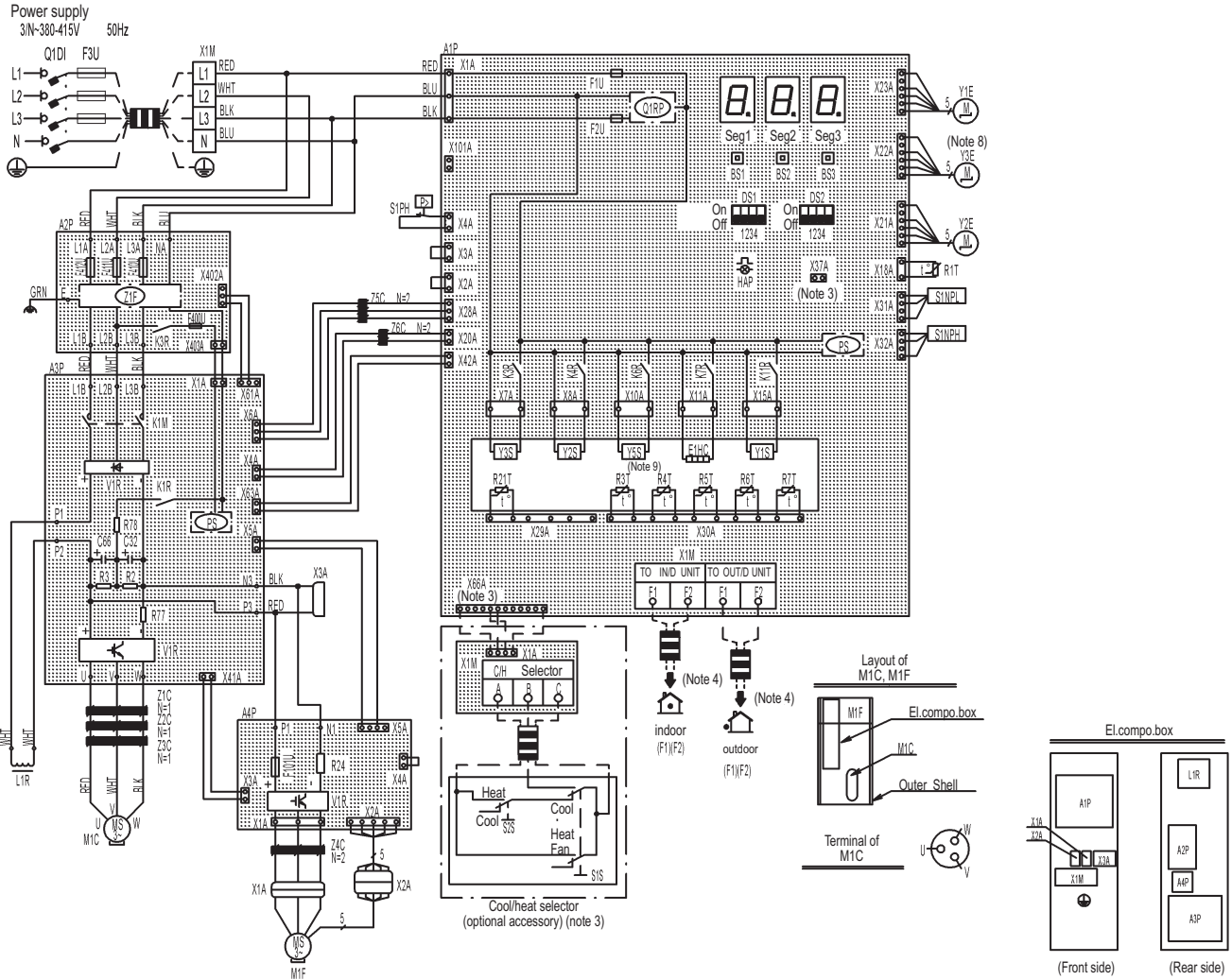

A1P	Printed circuit board (main)	K11R	Magnetic relay (Y1S) (A1P)	SEG1-SEG3	7-segment display (A1P)
A2P	Printed circuit board (noise filter)	L1R	Reactor	V1R	Power module (A3P) (A4P)
A3P	Printed circuit board (inv)	M1C	Motor (compressor)	X1A, X2A	Connector (M1F)
A4P	Printed circuit board (fan)	M1F	Motor (fan)	X3A	Connector (check the residual charge)
BS1~3	Push button, switch (A1P) (mode, set, return)	PS	Switching power supply (A1P, A3P)	X1M	Terminal block (power supply)
C32, C66	Capacitor (A3P)	Q1DI	Field earth leakage breaker	X1M	Terminal block (control) (A1P)
DS1, DS2	Dip switch (A1P)	QR1P	Phase reversal detect circuit (A1P)	Y1E	Electronic expansion valve (main)
E1HC	Crankcase heater	R1T	Thermistor (AIR) (A1P)	Y2E	Electronic expansion valve (injection)
F1U, F2U	Fuse (T, 3, 15A, 250V) (A1P)	R21T	Thermistor (M1C discharge)	Y3E	Electronic expansion valve (storage vessel) (note 8)
F3U	Field fuse	R3T	Thermistor (accumulator)	Y1S	Solenoid valve (main)
F101U	Fuse (A4P)	R4T	Thermistor (heat exc, liq, pipe)	Y2S	Solenoid valve (accumulator oil return)
F400U	Fuse (A2P)	R5T	Thermistor (subcool liq, pipe)	Y3S	Solenoid valve (OIL1)
F410U ~ F412U	Fuse (A2P)	R6T	Thermistor (heat exc, gas pipe)	Y5S	Solenoid valve (sub) (note 9)
HAP	Pilotlamp (service monitor-green) (A1P)	R7T	Thermistor (heat exc, deicer)	Z1C-Z6C	Noise filter (ferrite core)
K1M	Magnetic relay (A3P)	R2, R3	Resistor (A3P)	Z1F	Noise filter (A2P) (with surge absorber)
K1R	Magnetic relay (A3P)	R24	Resistor (current sensor) (A4P)		
K3R	Magnetic relay (A2P)	R77	Resistor (current sensor) (A3P)		
K3R	Magnetic relay (Y3S) (A1P)	R78	Resistor (current limiting) (A3P)		
K4R	Magnetic relay (Y2S) (A1P)	S1NPH	Pressure sensor (high)		Connector for optional accessories
K6R	Magnetic relay (Y5S) (A1P)	S1NPL	Pressure sensor (low)	X37A	Connector (power adapter)
K7R	Magnetic relay (E1HC) (A1P)	S1PH	Pressure switch (disch)	X66A	Connector (remote switching cool/heat selector)

### NOTES

- This wiring diagram applies only to the outdoor unit.
- : field wiring, □: terminal block, □□: connector, ○: terminal, ⊕: Protective earth (SREW)
- When using the optional adapter, refer to the installation manual of the optional adapter.
- For connection wiring to indoor-outdoor transmission F1-F2, outdoor-outdoor transmission F1-F2, refer to the installation manual.
- How to use BS1~3 switch. Refer to "service precaution" label on el, compo, box cover.
- When operating, don't shortcircuit the protection device (S1PH)
- Colors blk: black, red: red, blu: blue, wht: white, grn: green.
- Only for RYYQ model.
- Only for RYYQ/RYMQ model.

2D083677

# 9 Wiring diagrams

## 9 - 1 Wiring Diagrams - Three Phase

9

RYYQ10-12T  
RYMQ10-12T  
RXYQ10-12T

Power supply  
3N-380-415V 50Hz

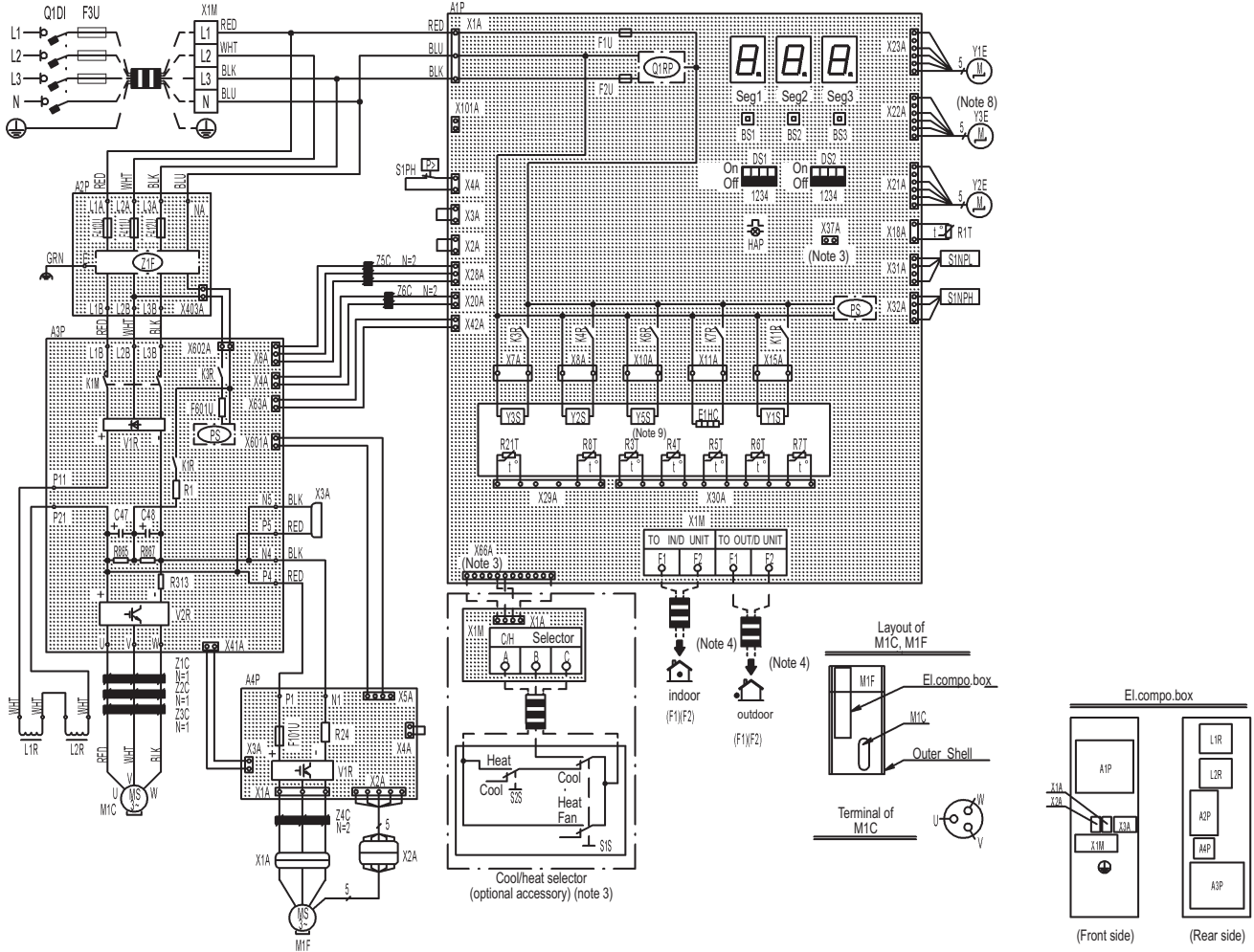

A1P	Printed circuit board (main)	K11R	Magnetic relay (Y1S) (A1P)	S1PH	Pressure switch (disch)
A2P	Printed circuit board (noise filter)	L1R, L2R	Reactor	SEG1~SEG3	7-segment display (A1P)
A3P	Printed circuit board (inv)	M1C	Motor (compressor)	V1R	Power module (A3P) (A4P)
A4P	Printed circuit board (fan)	M1F	Motor (fan)	V2R	Power module (A3P)
BS1~3	Push button, switch (A1P) (mode, set, return)	PS	Switching power supply (A1P, A3P)	X1A, X2A	Connector (M1F)
C47, C48	Capacitor (A3P)	Q1DI	Field earth leakage breaker	X3a	Connector (check the residual charge)
DS1, DS2	Dip switch (A1P)	QR1P	Phase reversal detect circuit (A1P)	X1M	Terminal block (power supply)
E1HC	Crankcase heater	R1T	Thermistor (AIR) (A1P)	X1M	Terminal block (control) (A1P)
F1U, F2U	Fuse (T, 3, 15A, 250V) (A1P)	R21T	Thermistor (subcool liq. pipe)	Y1E	Electronic expansion valve (main)
F101U	Fuse (A4P)	R3T	Thermistor (accumulator)	Y2E	Electronic expansion valve (injection)
F3U	Field fuse	R4T	Thermistor (heat exc, liq. pipe)	Y3E	Electronic expansion valve (storage vessel) (note 8)
F410U ~ F412U	Fuse (A2P)	R5T	Thermistor (M1C discharge)	Y1S	Solenoid valve (main)
F601U	Fuse (A3P)	R6T	Thermistor (heat exc, gas pipe)	Y2S	Solenoid valve (accumulator oil return)
HAP	Pilotlamp (service monitor-green) (A1P)	R7T	Thermistor (heat exc, deicer)	Y3S	Solenoid valve (OIL1)
K1M	Magnetic contactor (A3P)	R8T	Thermistor (M1C body)	Y5S	Solenoid valve (sub) (note 9)
K1R	Magnetic relay (A3P)	R1	Resistor (current limiting) (A3P)	Z1C~Z6C	Noise filter (ferrite core)
K3R	Magnetic relay (A3P)	R24	Resistor (current sensor) (A4P)	Z1F	Noise filter (A2P) (with surge absorber)
K3R	Magnetic relay (Y3S) (A1P)	R313	Resistor (current sensor) (A3P)		
K4R	Magnetic relay (Y2S) (A1P)	R865, R867	Resistor (A3P)		Connector for optional accessories
K6R	Magnetic relay (Y5S) (A1P)	S1NPH	Pressure sensor (high)	X37A	Connector (power adapter)
K7R	Magnetic relay (E1HC) (A1P)	S1NPL	Pressure sensor (low)	X66A	Connector (remote switching cool/heat selector)

### NOTES

- This wiring diagram applies only to the outdoor unit.
- : field wiring, □□□□: terminal block, □○□: connector, ○-○: terminal, ⊕: Protective earth (SREW)
- When using the optional adapter, refer to the installation manual of the optional adapter.
- For connection wiring to indoor-outdoor transmission F1-F2, outdoor-outdoor transmission F1-F2, refer to the installation manual.
- How to use BS1~3 switch. Refer to "service precaution" label on el. compo. box cover.
- When operating, don't shortcircuit the protection device (S1PH)
- Colors blk: black, red: red, blu: blue, wht: white, grn: green.
- Only for RYYQ model.
- Only for RYYQ/RYMQ model.

2D083678



# 9 Wiring diagrams

## 9 - 1 Wiring Diagrams - Three Phase

RYYQ14-16T  
RYMQ14-16T  
RXYQ14-16T

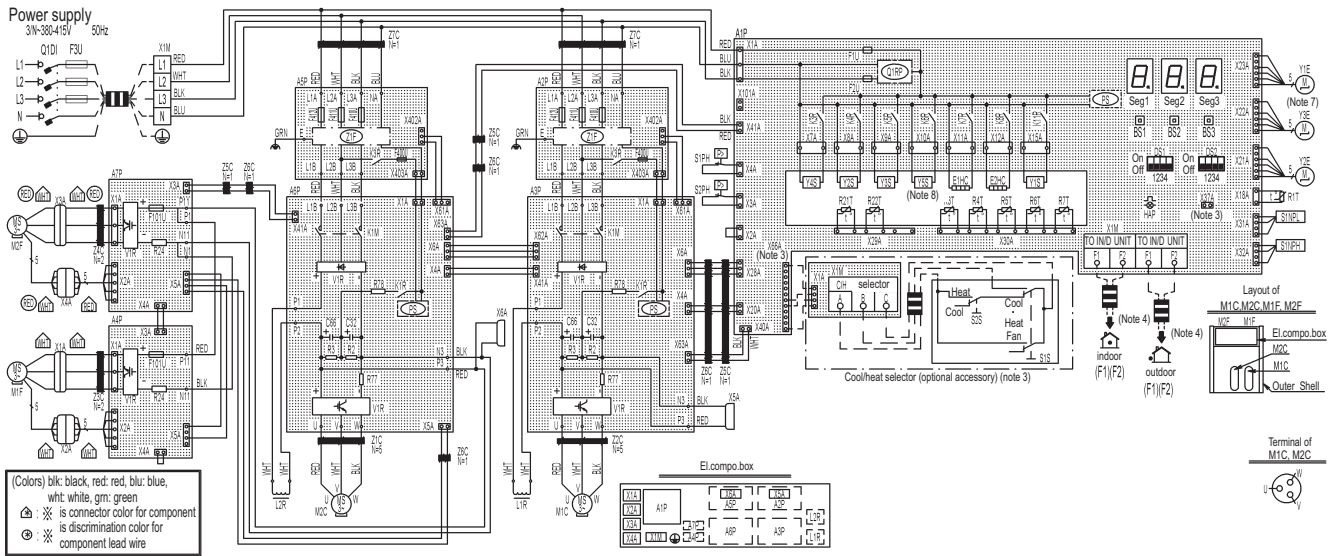

A1P	Printed circuit board (main)	K8R	Magnetic relay (E2HC) (A1P)	SEG1-SEG3	7-segment display (A1P)
A2P, A5P	Printed circuit board (noise filter)	K11R	Magnetic relay (Y1S) (A1P)	V1R	Power module (A3P, A6P)
A3P, A6P	Printed circuit board (inv)	L1R, L2R	Reactor	V1R	Power module (A4P, A7P)
A4P, A7P	Printed circuit board (fan)	M1C, M2C	Motor (compressor)	X1A~4A	Connector (M1F, M2F)
BS1-3	Push button, switch (A1P) (mode, set, return)	M1F, M2F	Motor (fan)	X5A~X6A	Connector (check the residual charge)
C32, C66	Capacitor (A3P), (A6P)	PS	Switching power supply (A1P, A3P, A6P)	X1M	Terminal block (power supply)
DS1, DS2	Dip switch (A1P)	Q1DI	Field earth leakage breaker	X1M	Terminal block (control) (A1P)
E1HC, E2HC	Crankcase heater	QR1P	Phase reversal detect circuit (A1P)	Y1E	Electronic expansion valve (main)
F1U, F2U	Fuse (T, 3, 15A, 250V) (A1P)	R2, R3	Resistor (A3P, A6P)	Y2E	Electronic expansion valve (injection)
F101U	Fuse (A4P, A7P)	R24	Resistor (current sensor) (A4P, A7P)	Y3E	Electronic expansion valve (storage vessel) (note 7)
F3U	Field fuse	R77	Resistor (current sensor) (A3P, A6P)	Y1S	Solenoid valve (main)
F400U	Fuse (A2P, A5P)	R78	Resistor (current limiting) (A3P, A6P)	Y2S	Solenoid valve (accumulator oil return)
F410U ~ F412U	Fuse (A2P, A5P)	R1T	Thermistor (AIR) (A1P)	Y3S	Solenoid valve (OIL1)
HAP	Pilotlamp (service monitor-green) (A1P)	R21T, R22T	Thermistor (M1C, MC2 discharge)	Y4S	Solenoid valve (OIL2)
K1M	Magnetic contactor (A3P, A6P)	R3T	Thermistor (accumulator)	Y5S	Solenoid valve (sub) (note 8)
K1R	Magnetic relay (A3P, A6P)	R4T	Thermistor (heat exc, liq, pipe)	Z1C-Z7C	Noise filter (ferrite core)
K3R	Magnetic relay (A2P, A6P)	R5T	Thermistor (subcool liq, pipe)	Z1F	Noise filter (A2P, A5P) (with surge absorber)
K3R	Magnetic relay (Y4S) (A1P)	R6T	Thermistor (heat exc, gas pipe)		
K4R	Magnetic relay (Y2S) (A1P)	R7T	Thermistor (heat exc, deicer)		
K5R	Magnetic relay (Y3S) (A1P)	S1NPH	Pressure sensor (high)		Connector for optional accessories
K6R	Magnetic relay (Y5S) (A1P)	S1NPL	Pressure sensor (low)	X37A	Connector (power adapter)
K7R	Magnetic relay (E1HC) (A1P)	S1PH, S2PH	Pressure switch (disch)	X66A	Connector (remote switching cool/heat selector)

### NOTES

- This wiring diagram applies only to the outdoor unit.
- :field wiring, □□□□ : terminal block, □□□ : connector, ○-○ : terminal, ⊕ : Protective earth (SREW)
- When using the optional adapter, refer to the installation manual of the optional adapter.
- For connection wiring to indoor-outdoor transmission F1-F2, outdoor-outdoor transmission F1-F2, refer to the installation manual.
- How to use BS1-3 switch. Refer to "service precaution" label on el, compo, box cover.
- When operating, don't shortcircuit the protection device (S1PH, S2PH)
- Only for RYYQ model.
- Only for RYYQ/RYMQ model.

# 9 Wiring diagrams

## 9 - 1 Wiring Diagrams - Three Phase

9

RYYQ18-20T  
RYYQ18-20T  
RYYQ18-20T

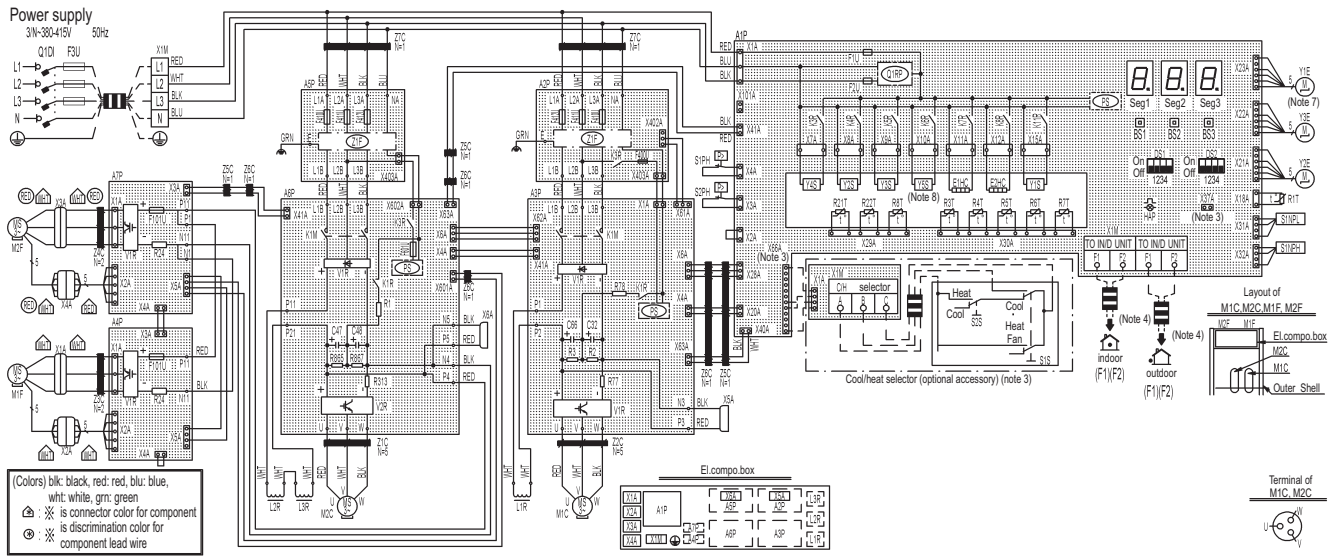

A1P	Printed circuit board (main)	K11R	Magnetic relay (Y1S) (A1P)	SEG1~SEG3	7-segment display (A1P)
A2P, A5P	Printed circuit board (noise filter)	L1R ~ L3R	Reactor	V1R	Power module (A3P, A6P)
A3P, A6P	Printed circuit board (inv)	M1C, M2C	Motor (compressor)	V1R	Power module (A4P, A7P)
A4P, A7P	Printed circuit board (fan)	M1F, M2F	Motor (fan)	V2R	Power module (A6P)
BS1~3	Push button, switch (A1P) (mode, set, return)	PS	Switching power supply (A1P, A3P, A6P)	X1A~4A	Connector (M1F, M2F)
C32, C46	Capacitor (A3P)	Q1DI	Field earth leakage breaker	X5A~X6A	Connector (check the residual charge)
C47, C48	Capacitor (A6P)	QR1P	Phase reversal detect circuit (A1P)	X1M	Terminal block (power supply)
DS1, DS2	Dip switch (A1P)	R1	Resistor (current limiting) (A6P)	X1M	Terminal block (control) (A1P)
E1HC, E2HC	Crankcase heater	R2, R3	Resistor (A3P)	Y1E	Electronic expansion valve (main)
F1U, F2U	Fuse (T, 3, 15A, 250V) (A1P)	R24	Resistor (current sensor) (A4P, A7P)	Y2E	Electronic expansion valve (injection)
F3U	Field fuse	R77	Resistor (current sensor) (A3P)	Y3E	Electronic expansion valve (storage vessel) (note 7)
F101U	Fuse (A4P, A7P)	R78	Resistor (current limiting) (A3P)	Y1S	Solenoid valve (main)
F400U	Fuse (A2P)	R313	Resistor (current sensor) (A6P)	Y2S	Solenoid valve (accumulator oil return)
F410U ~ F412U	Fuse (A2P, A5P)	R865, R867	Resistor (A6P)	Y3S	Solenoid valve (OIL1)
F601U	Fuse (A6P)	R1T	Thermistor (AIR) (A1P)	Y4S	Solenoid valve (OIL2)
HAP	Pilotlamp (service monitor-green) (A1P)	R21T, R22T	Thermistor (M1C, MC2 discharge)	Y5S	Solenoid valve (sub) (note 8)
K1M	Magnetic contactor (A3P, A6P)	R3T	Thermistor (accumulator)	Z1C~Z7C	Noise filter (ferrite core)
K1R	Magnetic relay (A3P, A6P)	R4T	Thermistor (heat exc. liq. pipe)	Z1F	Noise filter (A2P, A5P) (with surge absorber)
K3R	Magnetic relay (A2P, A6P)	R5T	Thermistor (subcool liq. pipe)		
K3R	Magnetic relay (Y4S) (A1P)	R6T	Thermistor (heat exc. gas pipe)		
K4R	Magnetic relay (Y2S) (A1P)	R7T	Thermistor (heat exc. deicer)		
K5R	Magnetic relay (Y3S) (A1P)	R8T	Thermistor (M2C, body)		
K6R	Magnetic relay (Y5S) (A1P)	S1NPH	Pressure sensor (high)		Connector for optional accessories
K7R	Magnetic relay (E1HC) (A1P)	S1NPL	Pressure sensor (low)	X37A	Connector (power adapter)
K8R	Magnetic relay (E2HC) (A1P)	S1PH, S2PH	Pressure switch (disch)	X66A	Connector (remote switching cool/heat selector)

### NOTES

1. This wiring diagram applies only to the outdoor unit.
2. - - - : field wiring, □ □ □ □ : terminal block, □ □ □ □ : connector, ○ - ○ : terminal, ⊕ : Protective earth (SREW)
3. When using the optional adapter, refer to the installation manual of the optional adapter.
4. For connection wiring to indoor-outdoor transmission F1-F2, outdoor-outdoor transmission F1-F2, refer to the installation manual.
5. How to use BS1~3 switch. Refer to "service precaution" label on el, compo, box cover.
6. When operating, don't shortcircuit the protection device (S1PH, S2PH)
7. Only for RYYQ model.
8. Only for RYYQ/RYYMQ model.

# 10 External connection diagrams

## 10 - 1 External Connection Diagrams

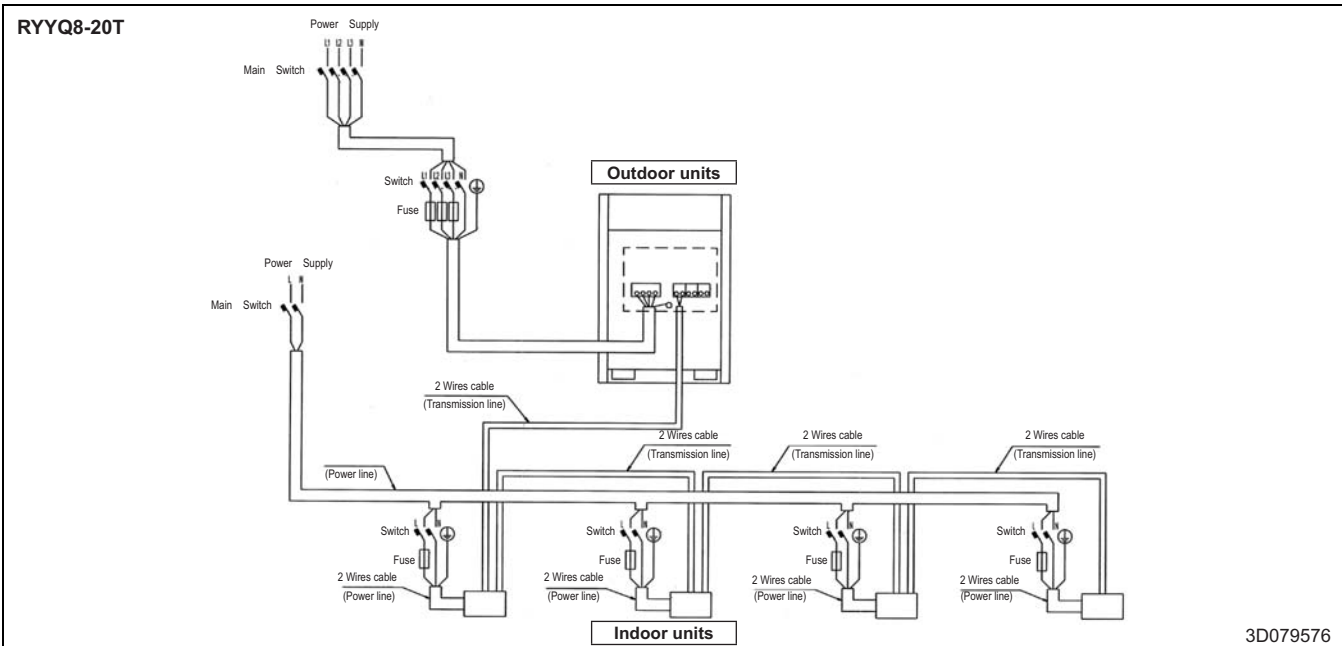

3D079576

**NOTES**

1. All wiring, components and materials to be procured on the site must comply with the applicable local and national codes.
2. Use copper conductors only.
3. As for details, see wiring diagram.
4. Install circuit breaker for safety.
5. All field wiring and components must be provided by licensed electrician.
6. Unit shall be grounded in compliance with the applicable local and national codes.
7. Wiring shown are general points-of-connection guides only and are not intended for or to include all details for a specific installation.
8. Be sure to install the switch and the fuse to the power line of each equipment.
9. Install the main switch that can interrupt all the power sources in an integrated manner because this system consists of the equipment utilizing the multiple power sources.
10. If there exists the possibility of reversed phase, lose phase, momentary blackout or the power goes on and off while the product is operating, attach a reversed phase protection circuit locally. Running the product in reversed phase may break the compressor and other parts.
11. Must install earth leakage circuit breaker.

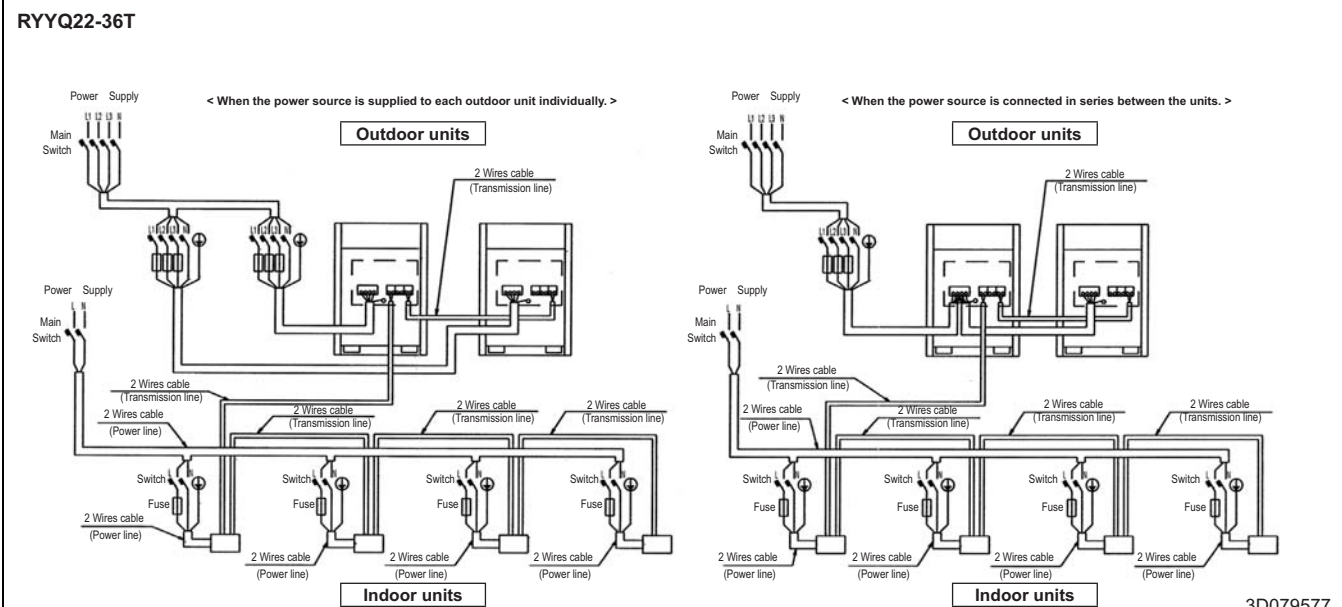

3D079577

**NOTES**

1. All wiring, components and materials to be procured on the site must comply with the applicable local and national codes.
2. Use copper conductors only.
3. As for details, see wiring diagram.
4. Install circuit breaker for safety.
5. All field wiring and components must be provided by licensed electrician.
6. Unit shall be grounded in compliance with the applicable local and national codes.
7. Wiring shown are general points-of-connection guides only and are not intended for or to include all details for a specific installation.
8. Be sure to install the switch and the fuse to the power line of each equipment.
9. Install the main switch that can interrupt all the power sources in an integrated manner because this system consists of the equipment utilizing the multiple power sources.
10. the capacity of UNIT1 must be larger than UNIT2 when the power source is connected in series between the units.
11. If there exists the possibility of reversed phase, lose phase, momentary blackout or the power goes on and off while the product is operating, attach a reversed phase protection circuit locally. Running the product in reversed phase may break the compressor and other parts.
12. Must install earth leakage circuit breaker.

# 10 External connection diagrams

## 10 - 1 External Connection Diagrams

10

**RYYQ38-54T** <When the power source is supplied to each outdoor unit individually>

**RYYQ38-54T** <When the power source is connected in series between the units>

3D079578

**NOTES**

1. All wiring, components and materials to be produced on the site must comply with the applicable local and national codes.
2. Use copper conductors only.
3. As for details, see wiring diagram.
4. Install circuit breaker for safety.
5. All field wiring and components must be provided by licensed electrician.
6. Unit shall be grounded in compliance with the applicable local and national codes.
7. Wiring shown are general points-of-connection guides only and are not intended for or to include all details for a specific installation.
8. Be sure to install the switch and the fuse to the power line of each equipment.
9. Install the main switch that can interrupt all the power sources in an integrated manner because this system consists of the equipment utilizing the multiple power sources.
10. The capacity of UNIT1 must be larger than UNIT2 when the power source is connected in series between the units.
11. If there exists the possibility of reversed phase, lose phase, momentary blackout or the power goes on and off while the product is operating, attach a reversed phase protection circuit locally.  
Running the product in reversed phase may break the compressor and other parts.
12. Must install earth leakage circuit breaker.

# 11 Sound data

## 11 - 1 Sound Power Spectrum

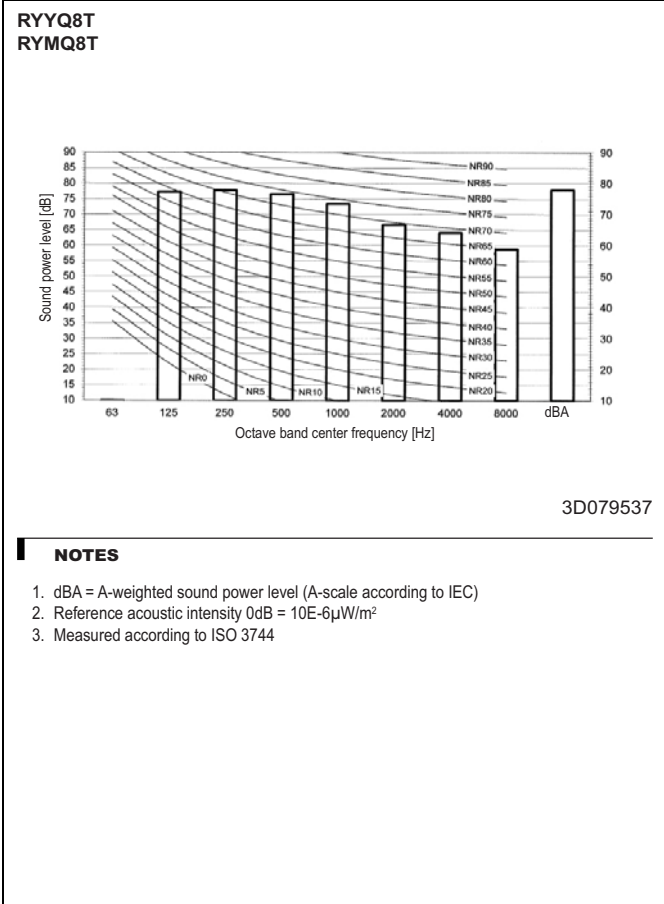

- NOTES**
1. dBA = A-weighted sound power level (A-scale according to IEC)
  2. Reference acoustic intensity  $0dB = 10E-6\mu W/m^2$
  3. Measured according to ISO 3744

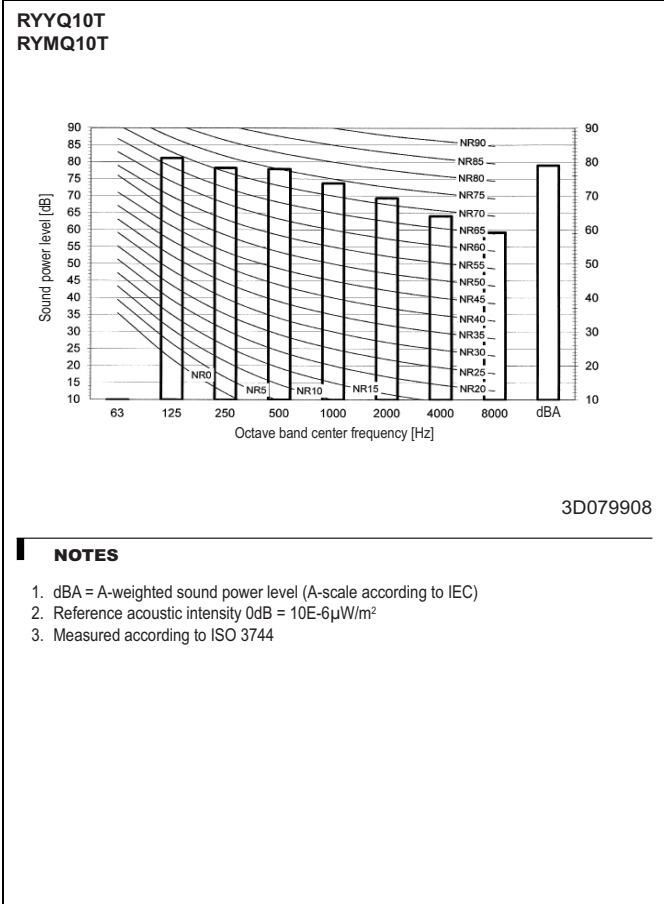

- NOTES**
1. dBA = A-weighted sound power level (A-scale according to IEC)
  2. Reference acoustic intensity  $0dB = 10E-6\mu W/m^2$
  3. Measured according to ISO 3744

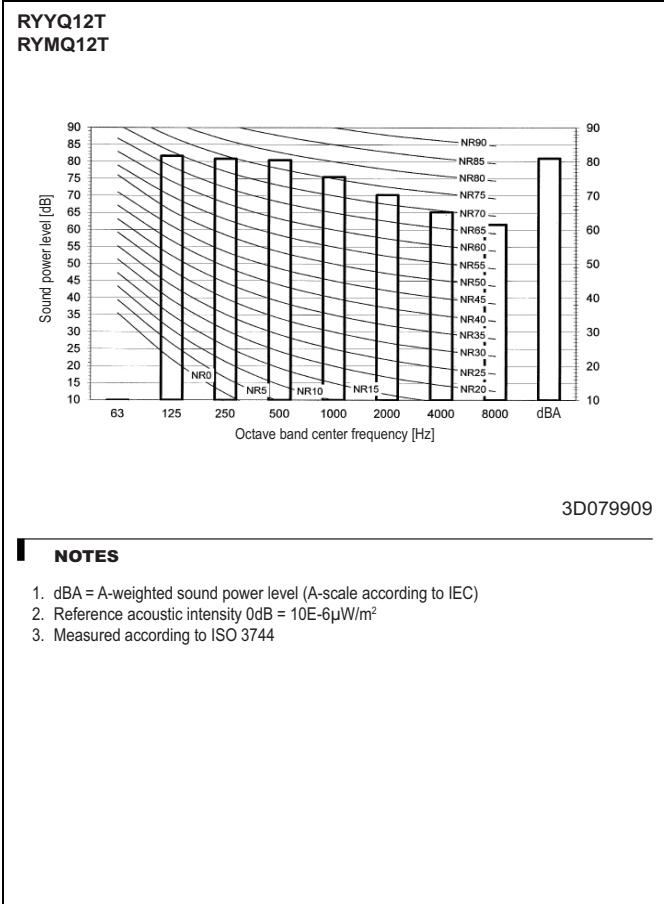

- NOTES**
1. dBA = A-weighted sound power level (A-scale according to IEC)
  2. Reference acoustic intensity  $0dB = 10E-6\mu W/m^2$
  3. Measured according to ISO 3744

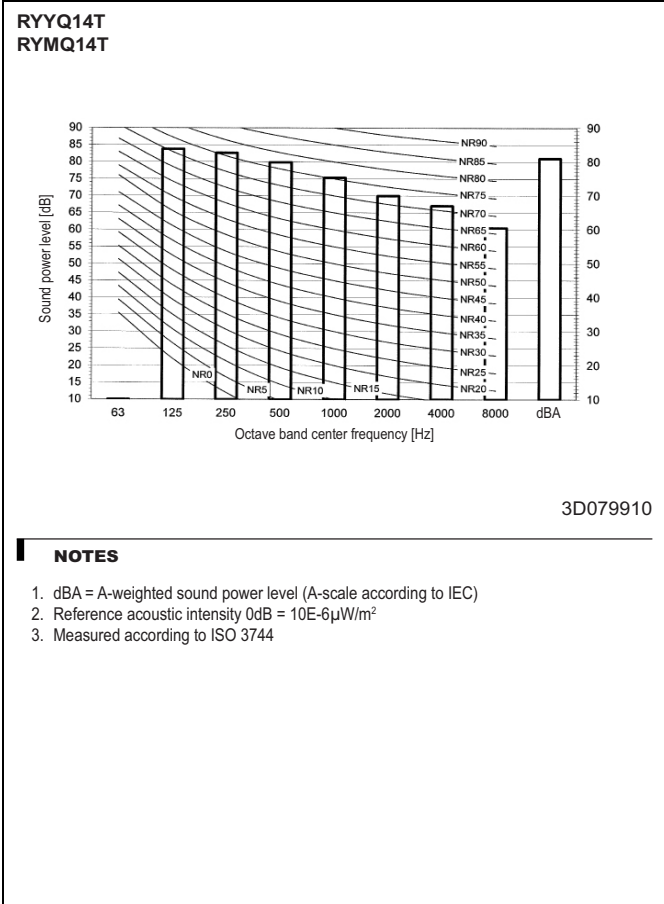

- NOTES**
1. dBA = A-weighted sound power level (A-scale according to IEC)
  2. Reference acoustic intensity  $0dB = 10E-6\mu W/m^2$
  3. Measured according to ISO 3744



# 11 Sound data

## 11 - 1 Sound Power Spectrum

11

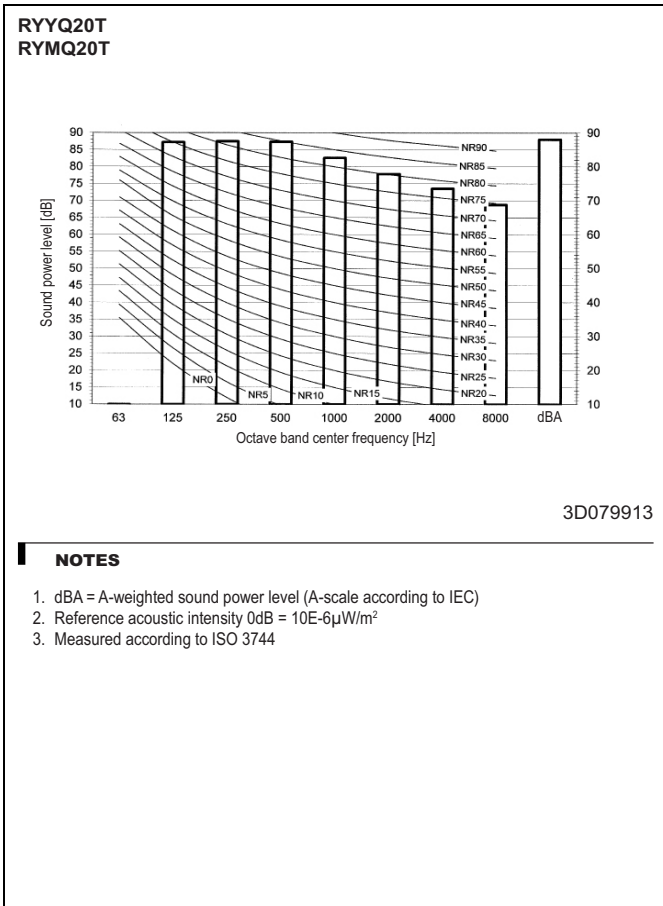
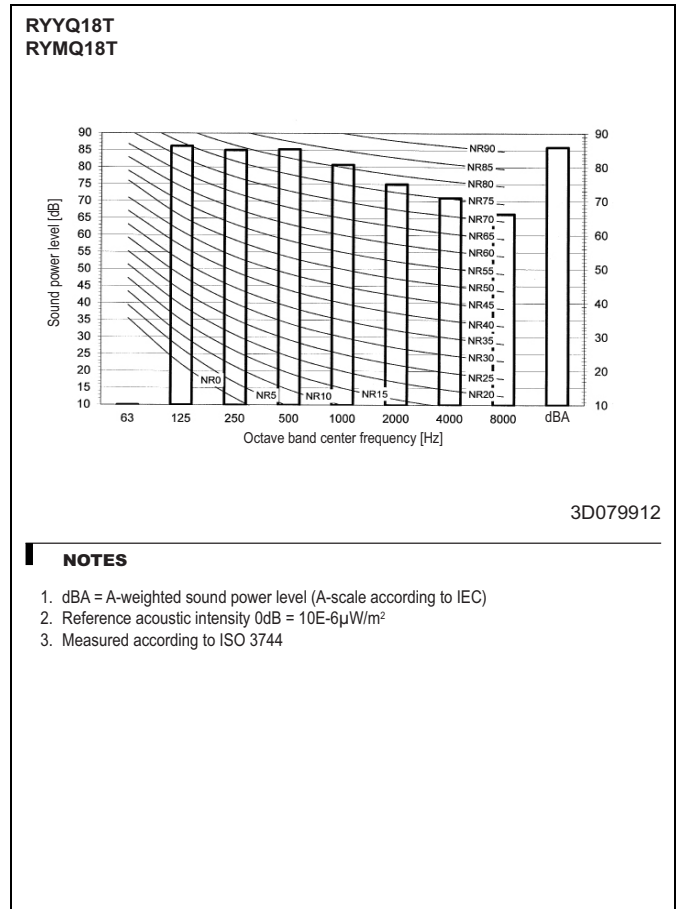
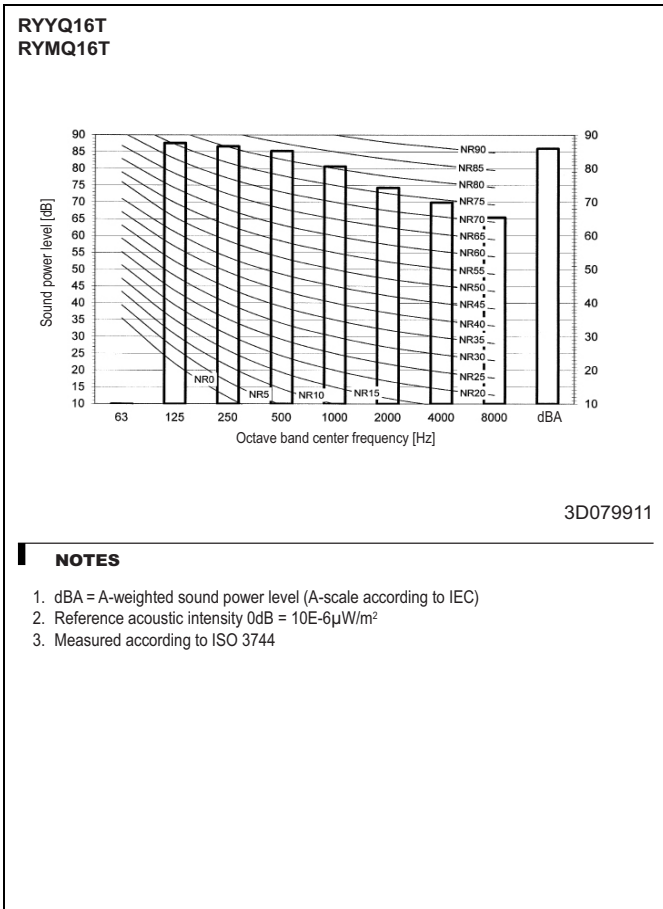

# 11 Sound data

## 11 - 2 Sound Pressure Spectrum

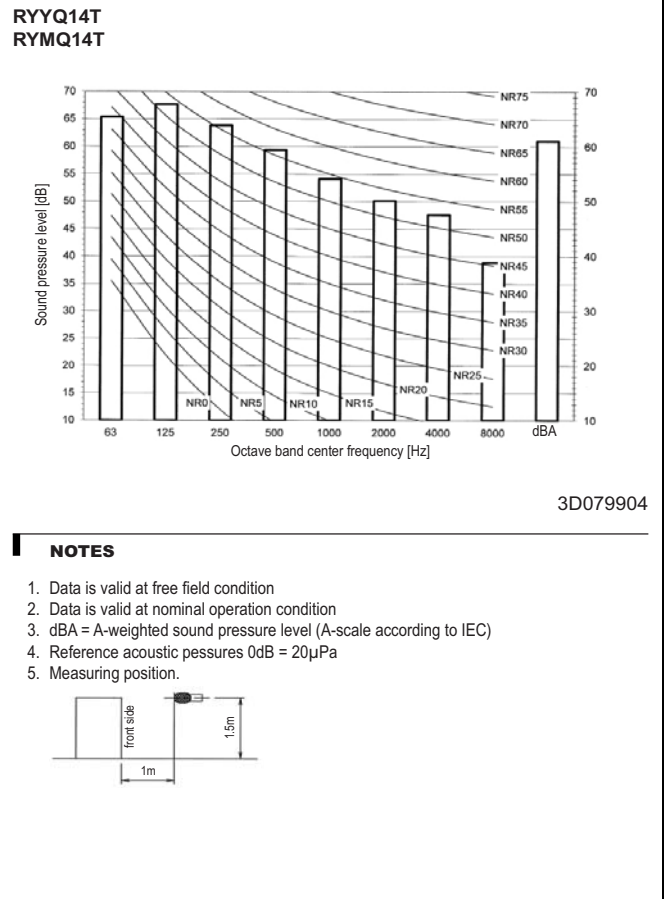
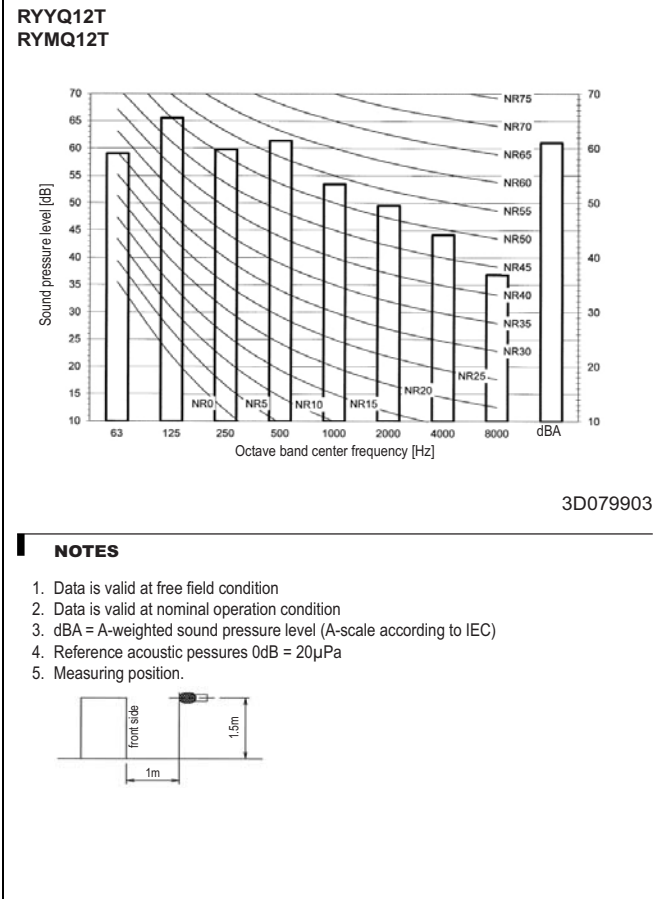
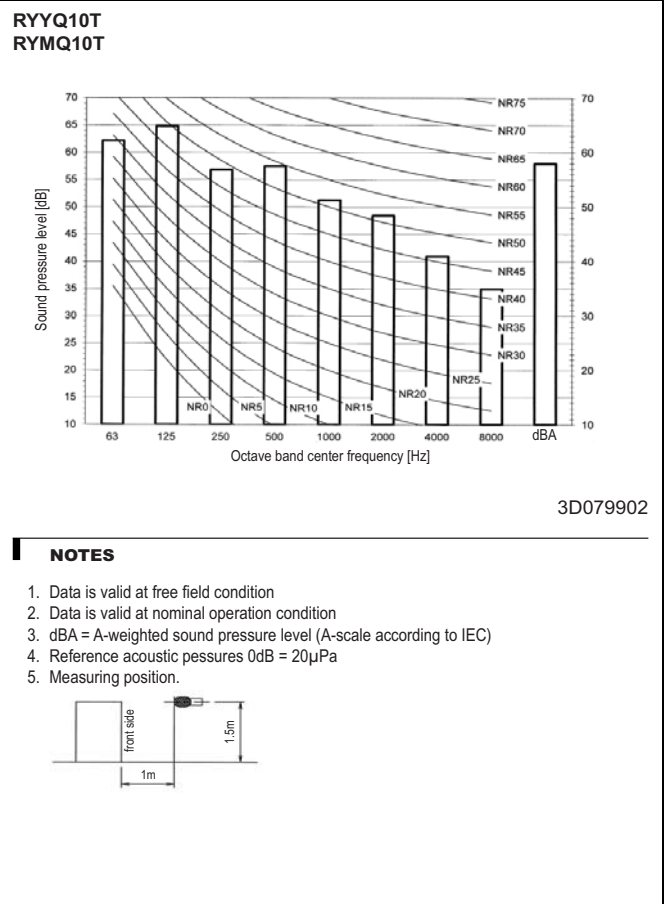
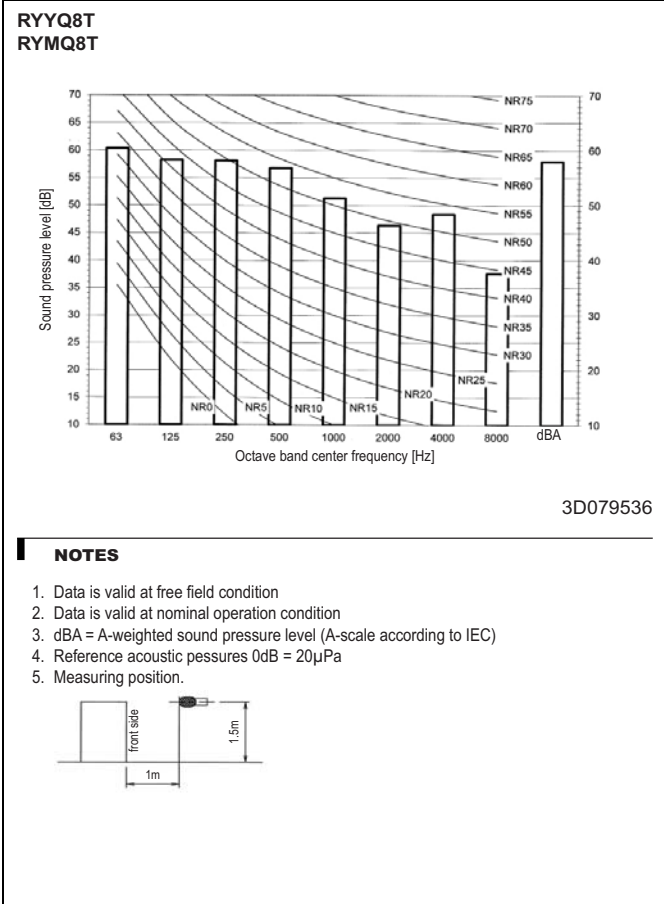

- NOTES**
1. Data is valid at free field condition
  2. Data is valid at nominal operation condition
  3. dBA = A-weighted sound pressure level (A-scale according to IEC)
  4. Reference acoustic pressures 0dB = 20μPa
  5. Measuring position.

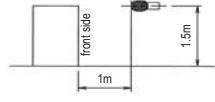

- NOTES**
1. Data is valid at free field condition
  2. Data is valid at nominal operation condition
  3. dBA = A-weighted sound pressure level (A-scale according to IEC)
  4. Reference acoustic pressures 0dB = 20μPa
  5. Measuring position.

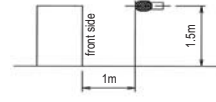

- NOTES**
1. Data is valid at free field condition
  2. Data is valid at nominal operation condition
  3. dBA = A-weighted sound pressure level (A-scale according to IEC)
  4. Reference acoustic pressures 0dB = 20μPa
  5. Measuring position.

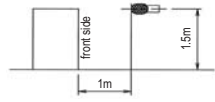

- NOTES**
1. Data is valid at free field condition
  2. Data is valid at nominal operation condition
  3. dBA = A-weighted sound pressure level (A-scale according to IEC)
  4. Reference acoustic pressures 0dB = 20μPa
  5. Measuring position.

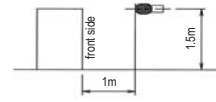

# 11 Sound data

## 11 - 2 Sound Pressure Spectrum

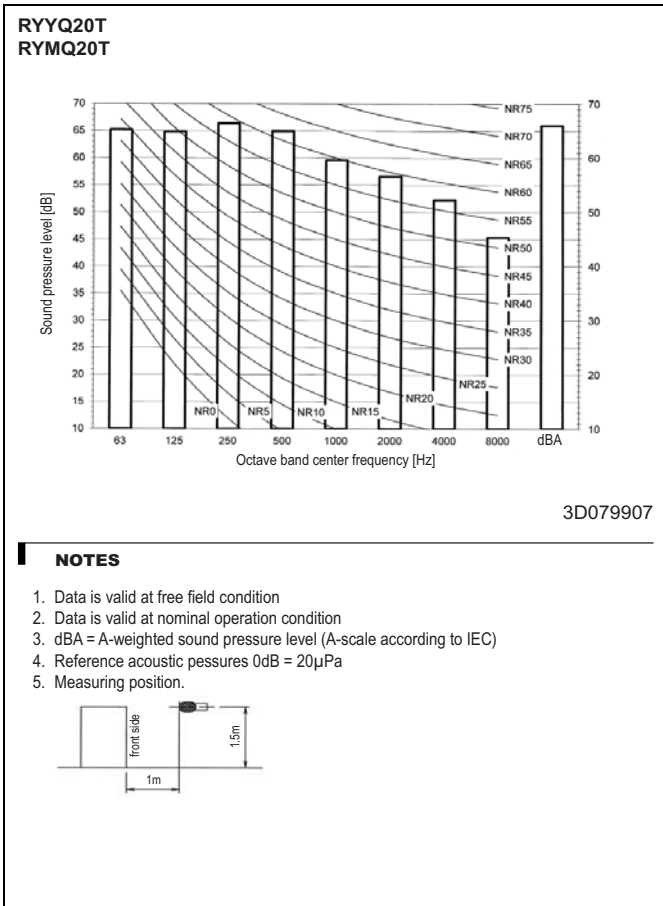
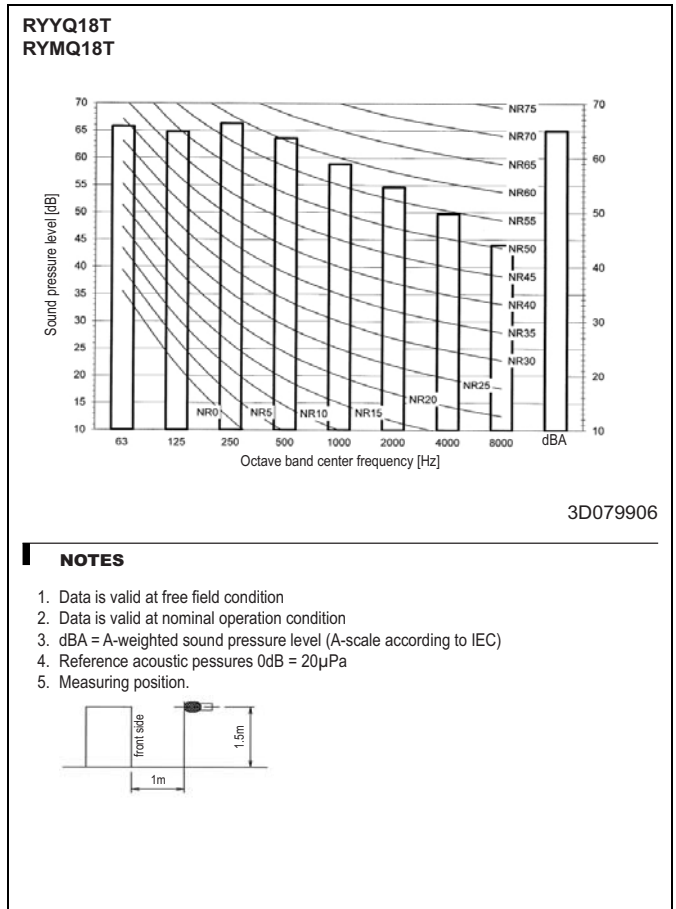
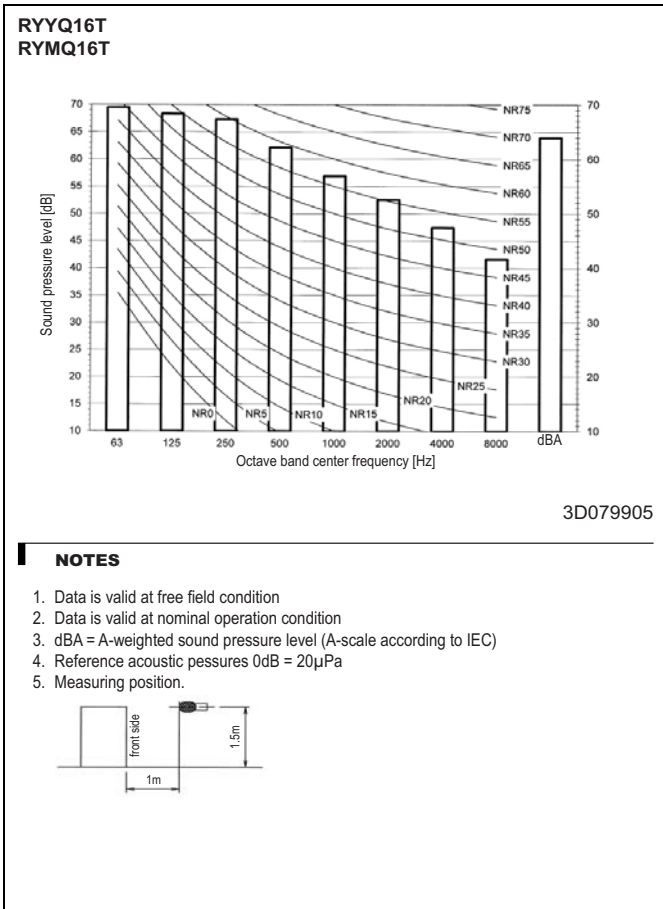



# 12 Installation

## 12 - 1 Installation Method

RYYQ-T  
RYMQ-T

For single unit installation

For installation in rows

For centralized group layout

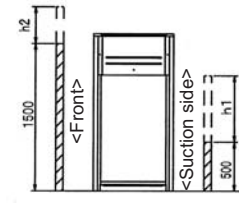
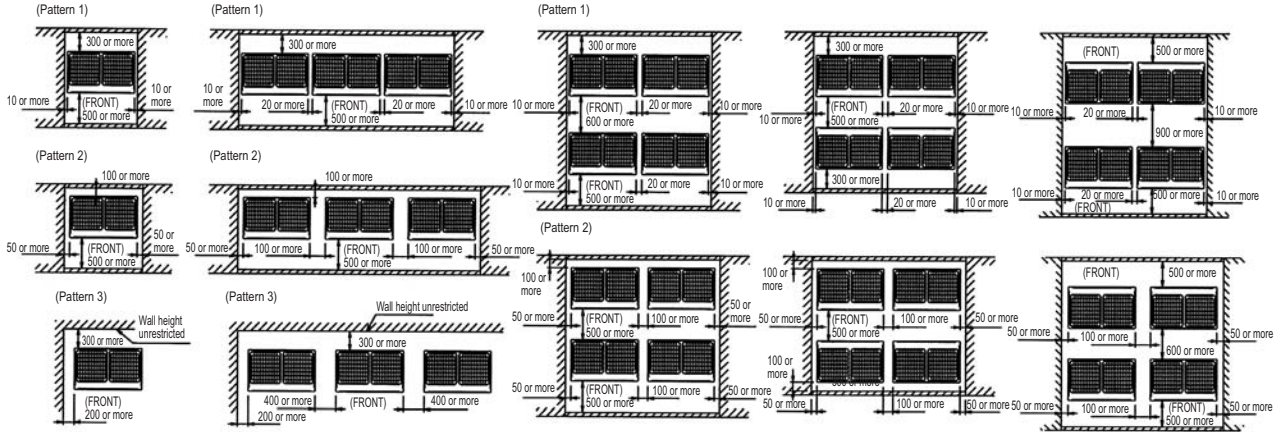

### NOTES

- Heights of walls in case of patterns 1 and 2:  
Front: 1500mm  
Suction side: 500mm  
Side: Height unrestricted  
Installation space as shown on this drawing is based on the cooling operation at 35 degrees outdoor air temperature.  
When the design outdoor air temperature exceeds 35 degrees or the load exceeds maximum ability of much generation load of heat in all outdoor unit, take the suction side space more broadly than the space as shown on this drawing.
- If the above wall heights are exceeded then  $h2/2$  and  $h1/2$  should be added to the front and suction side service spaces respectively as shown in the figure on the right.
- When installing the units most appropriate pattern should be selected from those shown above in order to obtain the best fit in the space available. Always keep in mind the need to leave enough space for a person to pass between units and wall and also for the air to circulate freely.  
(If more units are to be installed than are catered for in the above patterns your layout should take account of the possibility of short circuits).
- The units should be installed to leave sufficient space at the front for the on site refrigerant piping work to be carried out comfortably.

# 12 Installation

## 12 - 2 Fixation and Foundation of Units

12

RYYQ-T  
RYMQ-T  
RXYQ-T

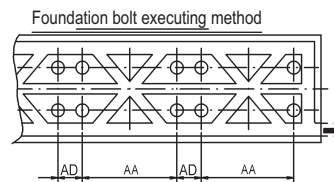
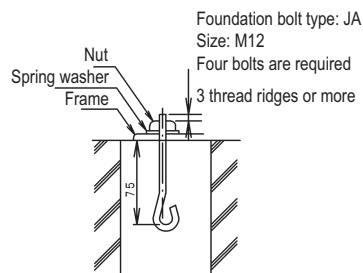
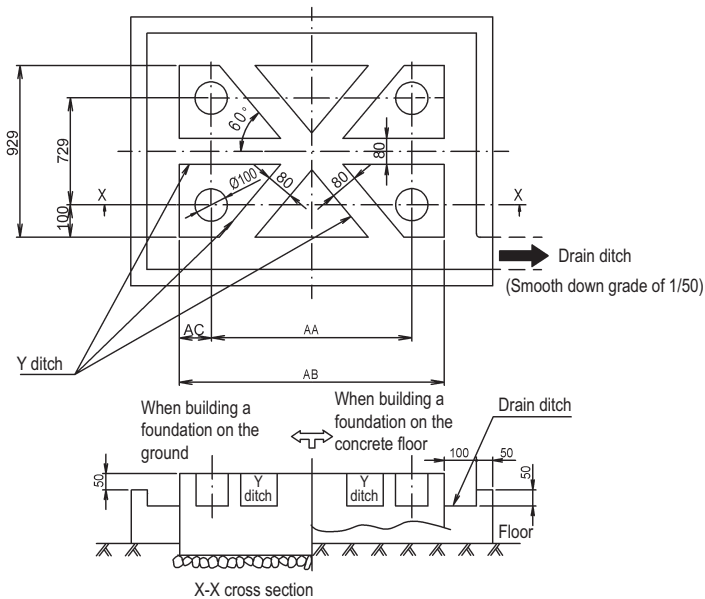

When installing multiple units in connection

Model	AA	AB	AC	AD
RYYQ8-12T	766	992	113	185
RYMQ8-12T				
RXYQ8-12T				
RYYQ14-20T	1076	1302	100	160
RYMQ14-20T				
RXYQ14-20T				
RXYCQ8	497	697	100	160
RXYCQ10-14	792	992		
RXYCQ16-20	1102	1302		

### NOTES

1. The proportions of cement: sand: gravel for the concrete shall be 1:2:4 and the reinforcement bars with a diameter of 10mm (approx, 300mm intervals) shall be placed.
2. The surface shall be finished with mortar. The corner edges shall be chamfered.
3. When the foundation is built on a concrete floor, rubble is not necessary, however, the surface of the section on which the foundation is built shall have a rough finish.
4. A drain ditch shall be made around the foundation to thoroughly drain water from the equipment installation area.
5. When installing the equipment on a roof, the floor strength shall be checked, and water-proofing measures shall be taken.

3D079547B

# 12 Installation

## 12 - 3 Refrigerant Pipe Selection

RYYQ-T  
RXYQ-T  
RYMQ-T

### 1. Refrigerant pipe size and allowable pipe length

#### 1.1. General information



**NOTICE**

The refrigerant R410A requires strict cautions for keeping the system clean, dry and tight.

- Clean and dry: foreign materials (including mineral oils or moisture) should be prevented from getting mixed into the system.
- Tight: R410A does not contain any chlorine, does not destroy the ozone layer, and does not reduce earth's protection against harmful ultraviolet radiation. R410A can contribute slightly to the greenhouse effect if it is released. Therefore we should take special attention to check the tightness of the installation.

#### 1.2. Selection of piping material



**NOTICE**

Piping and other pressure containing parts shall comply with the applicable legislation and shall be suitable for refrigerant. Use phosphoric acid deoxidised seamless copper for refrigerant.



**NOTICE**

Installation shall be done by a licensed installer, the choice of materials and installation shall conform completely with the applicable national and international codes.

In Europe, EN 378 is the applicable standard that shall be used.

- Foreign materials inside pipes (including oils for fabrication) must be ≤30 mg/10 m.
- Temper grade: use piping with temper grade in function of the pipe diameter as listed in table below.

Pipe Ø (mm)	Temper grade of piping material
≤15.9	O (annealed)
≥19.1	1/2H (half hard)

#### 1.3. Selection of piping size

Determine the proper size referring to following tables and reference figure (only for indication).

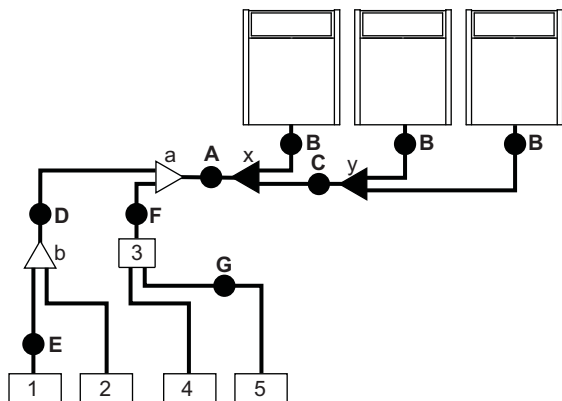

- 1,2 VRV DX indoor unit
- 3 BP box
- 4,5 RA DX indoor unit
- a,b Indoor branch kit
- x,y Outdoor multi connection kit

#### 1.3.1. Piping between outdoor unit and (first) refrigerant branch kit: A, B, C

Choose from the following table in accordance with the outdoor unit total capacity type, connected downstream.

Outdoor unit capacity type (HP)	Piping outer diameter size (mm)	
	Gas pipe	Liquid pipe
8	19.1	9.5
10	22.2	
12~16	28.6	12.7
18~22		15.9
24	34.9	19.1
26~34		
36~54	41.3	

#### 1.3.2. Piping between refrigerant branch kits: D

Choose from the following table in accordance with the indoor unit total capacity type, connected downstream. Do not let the connection piping exceed the refrigerant piping size chosen by the general system model name.

Indoor unit capacity index	Piping outer diameter size (mm)	
	Gas pipe	Liquid pipe
<150	15.9	9.5
150≤x<200	19.1	
200≤x<290	22.2	
290≤x<420	28.6	12.7
420≤x<640		15.9
640≤x<920	34.9	19.1
>920	41.3	19.1

Example:

Downstream capacity for E=capacity index of unit 1

Downstream capacity for D=capacity index of unit 1+capacity index of unit 2

#### 1.3.3. Piping between refrigerant branch kit and BP unit: F

Pipe size for direct connection on BP unit must be based on the total capacity of the connected indoor units (only in case RA DX indoor units are connected).

Total capacity index of connected indoor units	Gas pipe (mm)	Liquid pipe (mm)
20-62	12.7	6.4
63-149	15.9	9.5
150-208	19.1	

Example:

Downstream capacity for F=capacity index of unit 4+capacity index of unit 5

#### 1.3.4. Piping between BP unit and RA DX indoor unit: G

Only in case RA DX indoor units are connected.

Indoor unit capacity index	Gas pipe (mm)	Liquid pipe (mm)
20, 25, 30	9.5	6.4
50		
60	12.7	9.5
71	15.9	

4P329765-1C (1/5)

# 12 Installation

## 12 - 3 Refrigerant Pipe Selection

12

RYYQ-T  
RXYQ-T  
RYMQ-T

### 1.3.5. Piping between refrigerant branch kit and indoor unit: E

Pipe size for direct connection to indoor unit must be the same as the connection size of the indoor unit (in case indoor unit is VRV DX indoor or Hydrobox).

Indoor unit capacity index	Piping outer diameter size (mm)	
	Gas pipe	Liquid pipe
15, 20, 25, 32, 40, 50	12.7	6.4
63, 80, 100, 125	15.9	9.5
200	19.1	
250	22.2	

- When the equivalent pipe length between outdoor and indoor units is 90 m or more, the size of the main pipes (both gas side and liquid side) may be increased. Depending on the length of the piping, the capacity may drop, but even in such a case it is possible to increase the size of the main pipes.

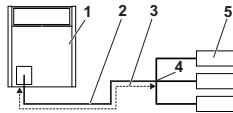

- Outdoor unit
- Main pipes
- Increase
- First refrigerant branch kit
- Indoor unit

Size up		
HP Class	Gas side (mm)	Liquid size (mm)
8	19.1 → 22.2	9.5 → 12.7
10	22.2 → 25.4 <sup>(a)</sup>	
12+14	28.6 <sup>(b)</sup>	12.7 → 15.9
16	28.6 → 31.8 <sup>(a)</sup>	
18~22	28.6 → 31.8 <sup>(a)</sup>	15.9 → 19.1
24	34.9 <sup>(b)</sup>	
26~34	34.9 → 38.1 <sup>(a)</sup>	19.1 → 22.2
36~54	41.3 <sup>(b)</sup>	

- (a) If size is NOT available, increase is NOT allowed.
- (b) Increase is NOT allowed.

- The pipe thickness of the refrigerant piping shall comply with the applicable legislation. The minimal pipe thickness for R410A piping must be in accordance with the table below.

Pipe Ø (mm)	Minimal thickness t (mm)
6.4	0.80
9.5	
12.7	
15.9	0.99
19.1	0.80
22.2	
28.6	0.99
34.9	1.21
41.3	1.43

- In case the required pipe sizes (inch sizes) are not available, it is also allowed to use other diameters (mm sizes), taken the following into account:
  - Select the pipe size nearest to the required size.
  - Use the suitable adapters for the change-over from inch to mm pipes (field supply).
 In this case, the additional refrigerant calculation has to be adjusted as mentioned in "14. Charging refrigerant".

### 1.4. Selection of refrigerant branch kits

#### Refrigerant refnets

For piping example, refer to "9.3. Selection of piping size".

- When using refnet joints at the first branch counted from the outdoor unit side, choose from the following table in accordance with the capacity of the outdoor unit (example: refnet joint a).

Outdoor unit capacity type (HP)	2 pipes
8-10	KHRQ22M29T9
12-22	KHRQ22M64T
24-54	KHRQ22M75T

- For refnets joints other than the first branch (example refnet joint b), select the proper branch kit model based on the total capacity index of all indoor units connected after the refrigerant branch.

Indoor unit capacity index	2 pipes
<200	KHRQ22M20T
200 ≤ x < 290	KHRQ22M29T9
290 ≤ x < 640	KHRQ22M64T
≥ 640	KHRQ22M75T

- Concerning refnet headers, choose from the following table in accordance with the total capacity of all the indoor units connected below the refnet header.

Indoor unit capacity index	2 pipes
<200	KHRQ22M29H
200 ≤ x < 290	KHRQ22M29H
290 ≤ x < 640	KHRQ22M64H <sup>(a)</sup>
≥ 640	KHRQ22M75H

- (a) If the pipe size above the refnet header is Ø34.9 or more, KHRQ22M75H is required.



#### INFORMATION

Maximum 8 branches can be connected to a header.

- How to choose an outdoor multi connection piping kit (needed if the outdoor unit capacity type is 22 HP or more). Choose from the following table in accordance with the number of outdoor units.

Number of outdoor units	Branch kit name
2	BHFQ22P1007
3	BHFQ22P1517

The RYYQ22~54 models, consisting of two or three RYMQ modules, require a 3-pipe system. There is an additional equalizing pipe for such modules (in addition to the conventional gas and liquid piping). This equalizing pipe does not exist for RYYQ8~20 or RYXQ8~54 units.

The equalizing pipe connections for the different RYMQ modules are mentioned in below table.

RYMQ	Equalizing pipe Ø (mm)
8	19.1
10	
12	
14	22.2
16	
18	
20	
	28.6

# 12 Installation

## 12 - 3 Refrigerant Pipe Selection

RYYQ-T  
RXYQ-T  
RYMQ-T

Deciding the equalizing pipe diameter:

- In case of 3 multi units: the connection diameter of outdoor to T-joint has to be kept.
- In case of 2 multi units: the connection pipe has to have the largest diameter.

There is never a connection of the equalizing pipe with the indoor units.

Example (free multi combination): RYMQ8+RYMQ12+RYMQ18. Largest connection is Ø28.6 (RYMQ18); Ø22.2 (RYMQ12) and Ø19.1 (RYMQ8). In figure below only equalizing pipe is shown.

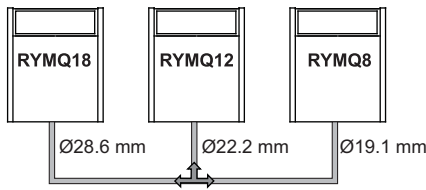

**INFORMATION**

Reducers or T-joints are field supplied.



**NOTICE**

Refrigerant branch kits can only be used with R410A.



**INFORMATION**

Equalizing pipe for RYMQ has to be connected between the outdoor modules of multi continuous heating models: RYYQ22~54 consisting of 2 or 3 RYMQ8~20 modules. The equalizing pipe should never have a connection to any indoor unit.

### 1.5. System piping (length) limitations

#### 1.5.1. Piping length restrictions

Make sure to perform the piping installation within the range of the maximum allowable pipe length, allowable level difference and allowable length after branching as indicated below. Three patterns will be discussed, including VRV DX indoor units combined with Hydrobox units or RA DX indoor units.

**Definitions**

Actual piping length: pipe length between outdoor<sup>(1)</sup> and indoor units.

Equivalent piping length<sup>(2)</sup>: pipe length between outdoor<sup>(1)</sup> and indoor units.

Total piping length: total piping length from the outdoor<sup>(1)</sup> to all indoor units.

Difference in height between outdoor and indoor units: H1.

Difference in height between indoor and indoor units: H2.

Difference in height between outdoor and outdoor units: H3.

Difference in height between outdoor and BP unit: H4.

Difference in height between BP unit and BP unit: H5.

Difference in height between BP unit and RA DX indoor unit: H6.

- (1) If the system capacity is >20HP, re-read "the first outdoor branch as seen from the indoor unit".
- (2) Assume equivalent piping length of refnet joint=0.5 m and refnet header=1 m (for calculation purposes of equivalent piping length, not for refrigerant charge calculations).

#### 1.5.2. System only containing VRV DX indoor units

**System setup**

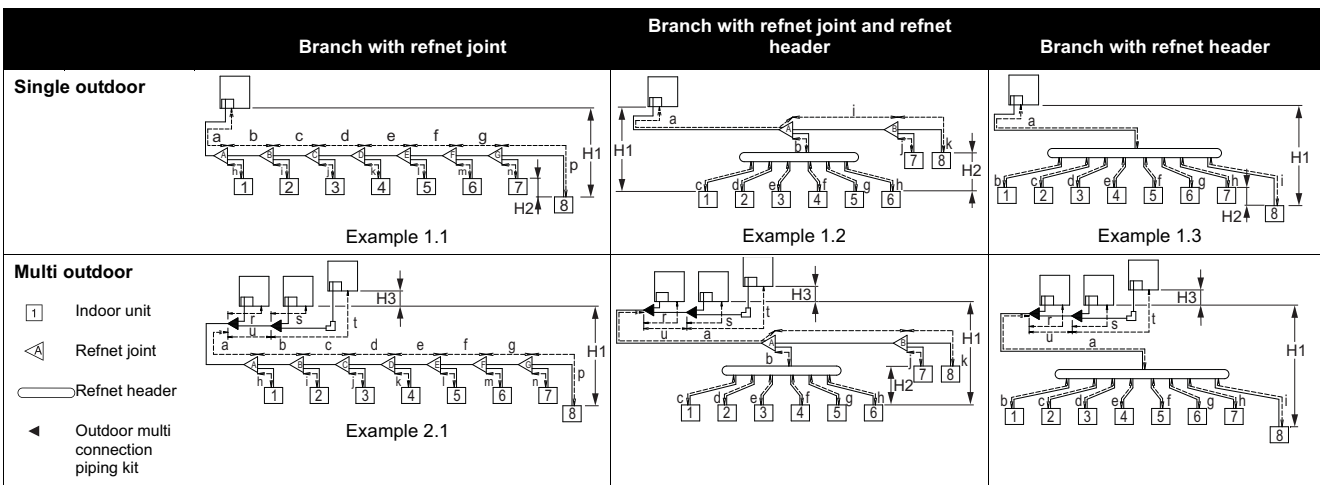

# 12 Installation

## 12 - 3 Refrigerant Pipe Selection

12

RYYQ-T  
RXYQ-T  
RYMQ-T

### Example 3: with standard multi layout

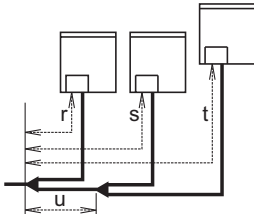

#### Maximum allowable length

Between outdoor and indoor units (standard multi/free multi combinations)

Actual piping length	165 m/135 m	<u>Example 1.1</u> unit 8: $a+b+c+d+e+f+g+p \leq 165$ m <u>Example 2.1</u> unit 8: $a+b+c+d+e+f+g+p \leq 135$ m	<u>Example 1.2</u> unit 6: $a+b+h \leq 165$ m unit 8: $a+i+k \leq 165$ m	<u>Example 1.3</u> unit 8: $a+i \leq 165$ m
Equivalent length <sup>(2)</sup>	190 m/160 m	—	—	—
Total piping length	1000 m/500 m	<u>Example 1.1</u> $a+b+c+d+e+f+g+h+i+j+k+l+m+n+p \leq 1000$ m <u>Example 2.1</u> $a+b+c+d+e+f+g+h+i+j+k+l+m+n+p \leq 500$ m	—	—

Between outdoor branch and outdoor unit (only in case >20 HP)

Actual piping length	10 m	<u>Example 3</u> $r, s, t \leq 10$ m; $u \leq 5$ m
Equivalent length	13 m	—

#### Maximum allowable height difference

H1	$\leq 50$ m (40 m) <sup>(a)</sup> (if outdoor is located below indoor units)
H2	$\leq 30$ m
H3	$\leq 5$ m

- (a) Conditional extension up till 90 m is possible without additional option kit:  
In case the outdoor location is higher than indoor: extension is possible up till 90 m and following 2 conditions must be fulfilled:  
Liquid piping size up (see table "Size up").  
Dedicated setting on outdoor unit is required (see "[2-49]").  
In case the outdoor location is lower than indoor: extension is possible up till 90 m and following 6 conditions must be fulfilled:  
40~60 m: minimum connection ratio connected: 80%.  
60~65 m: minimum connection ratio connected: 90%.  
65~80 m: minimum connection ratio connected: 100%.  
80~90 m: minimum connection ratio connected: 110%.  
Liquid piping size up (see table "Size up").  
Dedicated setting on outdoor unit is required (see "[2-35]").

#### Maximum allowable length after branch

The pipe length from the first refrigerant branch kit to the indoor unit  $\leq 40$  m.

Example 1.1: unit 8:  $b+c+d+e+f+g+p \leq 40$  m

Example 1.2: unit 6:  $b+h \leq 40$  m, unit 8:  $i+k \leq 40$  m

Example 1.3: unit 8:  $i \leq 40$  m

However, extension is possible if all below conditions are met. In this case limitation can be extended up to 90 m.

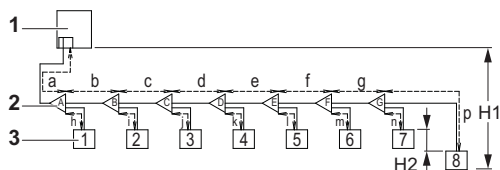

- 1 Outdoor units
- 2 Refnet joints (A~G)
- 3 Indoor unit (1~8)

a. The piping length between all indoor to the nearest branch kit is  $\leq 40$  m.

Example:  $h, l, j \dots p \leq 40$  m

b. It is necessary to increase the pipe size of the gas and liquid piping if the pipe length between the first and the final branch kit is over 40 m.

If the increased pipe size is larger than the pipe size of the main pipe, then the pipe size of the main pipe has to be increased as well.

Increase the pipe size as follows:

$9.5 \rightarrow 12.7$ ;  $12.7 \rightarrow 15.9$ ;  $15.9 \rightarrow 19.1$ ;  $19.1 \rightarrow 22.2$ ;  $22.2 \rightarrow 25.4$ <sup>(1)</sup>;  $28.6 \rightarrow 31.8$ <sup>(3)</sup>;  $34.9 \rightarrow 38.1$ <sup>(3)</sup>

Example: unit 8:  $b+c+d+e+f+g+p \leq 90$  m and  $b+c+d+e+f+g > 40$  m; increase the pipe size of b, c, d, e, f, g.

(1) If available on the site. Otherwise it cannot be increased.

# 12 Installation

## 12 - 3 Refrigerant Pipe Selection

RYYQ-T  
RXYQ-T  
RYMQ-T

- c. When the piping size is increased (step b), the piping length has to be counted as double (except for the main pipe and the pipes that are not increased in pipe size). The total piping length has to be within limitations (see table above).  
**Example:**  
 $a+b*2+c*2+d*2+e*2+f*2+g*2+h+i+j+k+l+m+n+p \leq 1000$  m (500 m).
- d. The piping length difference between the nearest indoor from first branch to the outdoor unit and farthest indoor to the outdoor unit is  $\leq 40$  m.  
**Example:** The farthest indoor unit 8. The nearest indoor unit 1  
 $\rightarrow (a+b+c+d+e+f+g+p)-(a+h) \leq 40$  m.

### 1.5.3. System containing VRV DX indoor units and Hydrobox

#### System setup

**Example 1:** Branch with refnet joint.

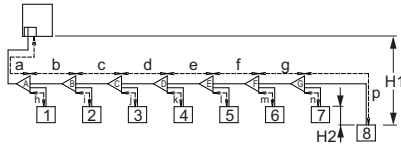

**Example 2:** Branch with refnet joint and refnet header.

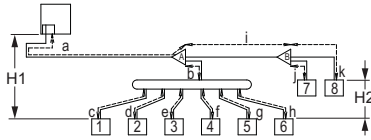

**Example 3:** Branch with refnet header

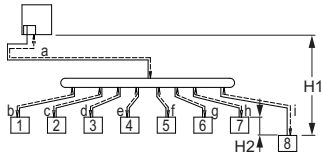

1-7 VRV DX indoor units  
8 Hydrobox unit (HXY\*)

#### Maximum allowable length

Between outdoor and indoor units.

Actual piping length	135 m	<b>Example 1:</b> $a+b+c+d+e+f+g+p \leq 135$ m $a+b+c+d+k \leq 135$ m
		<b>Example 2:</b> $a+i+k \leq 135$ m $a+b+e \leq 135$ m
		<b>Example 3:</b> $a+i \leq 135$ m $a+d \leq 135$ m
Equivalent length <sup>(a)</sup>	160 m	—
Total piping length	300 m	<b>Example 3:</b> $a+b+c+d+e+f+g+h+i \leq 300$ m

(a) Assume equivalent piping length of refnet joint=0.5 m and refnet header=1 m (for calculation purposes).

#### Maximum allowable height difference (on Hydrobox indoor unit)

H1	$\leq 50$ m (40 m) (if outdoor is located below indoor units)
H2	$\leq 15$ m

#### Maximum allowable length after branch

The pipe length from the first refrigerant branch kit to the indoor unit  $\leq 40$  m.

**Example 1:** unit 8:  $b+c+d+e+f+g+p \leq 40$  m

**Example 2:** unit 6:  $b+h \leq 40$  m, unit 8:  $i+k \leq 40$  m

**Example 3:** unit 8:  $i \leq 40$  m, unit 2:  $c \leq 40$  m

### 1.5.4. System containing VRV DX indoor units and RA DX indoor units

#### System setup

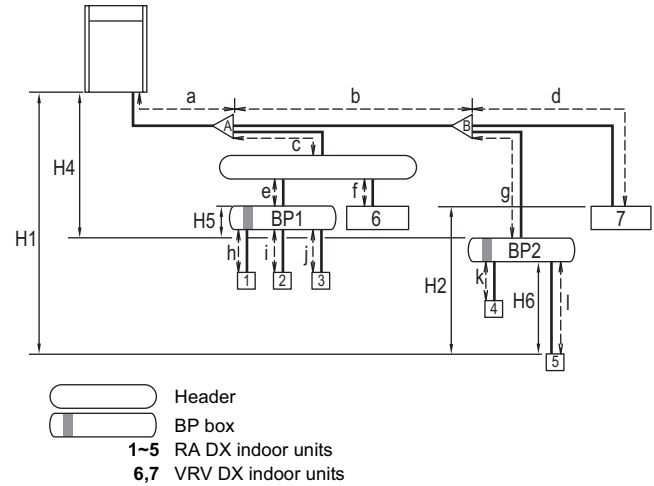

#### Maximum allowable length

- Between outdoor unit and indoor unit.

Actual piping length	100 m	<b>Example:</b> $a+b+g+l \leq 100$ m
Equivalent length <sup>(a)</sup>	120 m	—
Total piping length	250 m	<b>Example:</b> $a+b+d+g+l+k+c+e+f+h+i+j \leq 250$ m

(a) Assume equivalent piping length of refnet joint=0.5 m and refnet header=1 m (for calculation purposes).

- Between BP unit and indoor unit.

Indoor unit capacity index	Pipe length
<60	2~15 m
60	2~12 m
71	2~8 m

Remark:

**Minimum allowable length** between outdoor unit and first refrigerant branch kit  $> 5$  m (the refrigerant noise from the outdoor unit can be transmitted).

**Example:**  $a > 5$  m

#### Maximum allowable height difference

H1	$\leq 50$ m (40 m) (if outdoor is located below indoor units)
H2	$\leq 15$ m
H4	$\leq 40$ m
H5	$\leq 15$ m
H6	$\leq 5$ m

#### Maximum allowable length after branch

The pipe length from the first refrigerant branch kit to the indoor unit  $\leq 50$  m.

**Example:**  $b+g+l \leq 50$  m

If the piping length between the first branch and BP unit or VRV DX indoor unit is over 20 m, it is necessary to increase the gas and liquid piping size between the first branch and BP unit or VRV DX indoor unit. If the piping diameter of the sized up piping exceeds the diameter of the piping before the first branch kit, than the latter also requires a liquid piping and gas piping size up.



# 12 Installation

## 12 - 3 Refrigerant Pipe Selection

12

RYYQ-T  
RYMQ-T  
RXYQ-T

Reference drawing see page 2/3	Maximum piping length			Maximum height difference			Total Piping Length
	Longest pipe (A+[B,G,E,J]) Actual / (Equivalent)	After first branch (B,G,E,J) Actual	After first branch for outdoor multi (D) Actual / (Equivalent)	Indoor to outdoor <sup>(5)</sup> (H1)	Indoor to indoor <sup>(5)</sup> (H2)	Outdoor to outdoor <sup>(5)</sup> (H3)	
<b>Standard</b> Only VRV DX indoor connected Standard multi combination	165/(190)m	40m <sup>(1)</sup>	10/(13)m	50/40m <sup>(3)</sup>	30m	5m	1000m
<b>Free multi combination</b> (=all, except standard multi combination)	135/(160)m	40m <sup>(1)</sup>	10/(13)m	50/40m <sup>(3)</sup>	30m	5m	500m
<b>Hydrobox connection</b>	135/(160)m	40m	10/(13)m	50/40m	15m	5m	300-500m <sup>(5)</sup>
<b>RA connection</b>	100/(120)m	50m <sup>(2)</sup>	-	50/40m	15m	-	250m
<b>AHU connection</b>	Pair	50/(55)m <sup>(4)</sup>	-	40/40m	-	-	-
	Multi <sup>(6)</sup>	165/(190)m	40m	10/13m	40/40m	15m	1000m
	Mix <sup>(7)</sup>	165/(190)m	40m	10/13m	40/40m	15m	1000m

### NOTES

For standard multi combinations; see 3D079534

- (1) Extension is possible if all below conditions are met (limitation can be extended up to 90m)
  - a. The piping length between all indoor to the nearest branch kit is ≤ 40m.
  - b. It is necessary to increase the pipe size of the gas and liquid piping if the pipe length between the first and the final branch kit is over 40m.  
If the increased pipe size is larger than the pipe size of the main pipe, then the pipe size of the main pipe has to be increased as well.
  - c. When the piping size is increased (b), the piping length has to be counted as double. The total piping length has to be within limitations (see table above).
  - d. The piping length difference between the nearest indoor from first branch to the outdoor unit and farthest indoor to the outdoor unit is ≤ 40m.
- (2) If the piping length between the first branch and BP box or VRV indoor is over 20m, it's necessary to increase the gas and liquid piping size between first branch and BP box or VRV indoor.
- (3) Extension up till 90m is possible without additional option kit.
  - In case the outdoor location is higher than indoor: extension is possible up till 90m under following conditions:
    - Liquid piping size up (details in installation manual).
    - Dedicated setting on outdoor unit is required (details in installation manual).
  - In case the outdoor location is lower than indoor: extension is possible up till 90m under following conditions:
    - 40~60m: minimum connection ratio connected: 80%.
    - 60~65m: minimum connection ratio connected: 90%.
    - 65~80m: minimum connection ratio connected: 100%.
    - 80~90m: minimum connection ratio connected: 110%.
    - +
    - Liquid piping size up (details in installation manual).
    - Dedicated setting on outdoor unit is required (details in installation manual).
- (4) The allowable minimum length is 5 m.
- (5) In case of multi connection.
- (6) Using several AHU (EKEXV + EKEQ-kits)
- (7) Mix of AHU and VRV DX indoor

3D079540C(1/3)



# 12 Installation

## 12 - 3 Refrigerant Pipe Selection

RYYQ-T  
RYMQ-T  
RXYQ-T

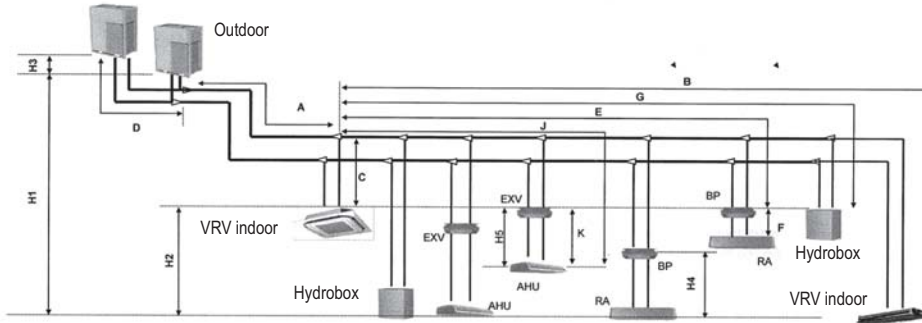

**NOTES**

1. Schematic indication: illustrations may vary from real unit outlook.
2. Displayed system is only to illustrate piping length limitations! Combination of displayed indoor unit types is not allowed. See 3D079543 for allowed combinations.

	Allowable piping length		Max. height difference	
	BP to RA (F)	EXV to AHU (K)	BP to RA (H4)	EXV to AHU (H5)
<b>RA connection</b>	2~15m	-	5m	-
<b>AHU connection</b>	Pair	≤5m	-	5m
	Multi <sup>(1)</sup>	≤5m	-	5m
	Mix <sup>(2)</sup>	≤5m	-	5m

**NOTES**

1. Using several AHU (EKEXV + EKEQ- kits)
2. Mix of AHU and VRV DX indoor

3D079540C(2/3)

RYYQ-T  
RYMQ-T  
RXYQ-T

System pattern Allowed connection ratio (CR)	Total		Allowable capacity			
	capacity	Indoor unit quantity (VRV, RA, AHU, Hydrobox) (excl. BP box and EXV kits)	VRV DX indoor	RA DX indoor	Hydrobox	AHU
* Other combinations are N.A.						
Only VRV DX indoor	50~130%	Max. 64	50~130%	-	-	-
VRV DX indoor + RA DX indoor	80~130%	Max. 32 <sup>(1)</sup>	0~130%	0~130%	-	-
Only RA DX indoor	80~130%	Max. 32 <sup>(1)</sup>	-	80~130%	-	-
VRV DX indoor + LT hydrobox	50~130%	Max. 32	50~130%	-	0~80%	-
VRV DX indoor + AHU (mix)	50~110% <sup>(3)</sup>	Max. 64 <sup>(2)</sup>	50~110%	-	-	0~110%
Only AHU (pair AHU + multi AHU) <sup>(4)</sup>	90~110% <sup>(3)</sup>	Max. 64 <sup>(2)</sup>	-	-	-	90~110%

**NOTES**

1. There is no restriction for the number of connectable BP boxes
2. When using AHU connection: see EKEXV kit as an indoor unit for counting the total number of indoor units
3. Restrictions by air handling unit capacity
4. Pair AHU = system with 1 AHU connected to one outdoor unit // Multi AHU = system with several AHU connected to 1 outdoor unit system

**SPECIAL INFORMATION REGARDING VENTILATION APPLICATIONS**

- FXMQ\_MF** model is considered as an AHU, following AHU limitations and respecting additional limitations:
  - Maximum FXMQ\_MF connection ratio (CR) when combined with VRV DX indoor units: CR ≤ 30%
  - Maximum FXMQ\_MF connection ratio (CR) when only AHU is used: CR ≤ 100%
  - (operation range information: see specifications of FXMQ\_MF unit)
- Biddle aircurtain** is considered as an AHU, following AHU limitations  
(operation range information: see specifications of Biddle unit)
- [EKEXV + EKEQ] combined with AHU** is considered as an AHU, following AHU limitations  
(operation range information: see specifications of EKEXV-EKEQ unit)
- VKM** is considered to be a regular VRV DX indoor unit  
(operation range information: see specifications of VKM unit)
- VAM** does not have limitations on connection as there is no refrigerant connection with the outdoor unit (only communication F1/F2; so counting in # indoor units)

3D079540C(3/3)

# 13 Operation range

## 13 - 1 Operation Range

13

RYYQ-T  
RYMQ-T

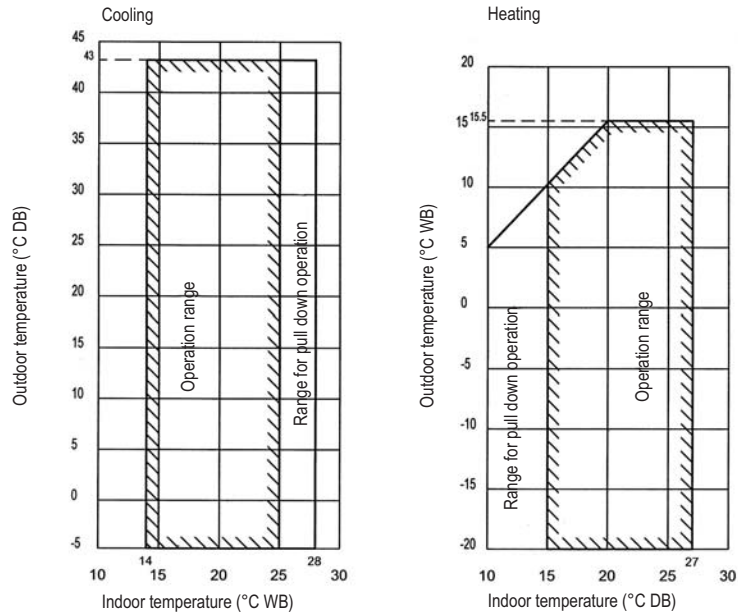

### NOTES

1. These figures assume the following operation conditions:  
Indoor and outdoor units:  
Equivalent pipe length: 5m  
Level difference: 0m
2. Depending on operation and installation conditions, the indoor unit can change over to freeze-up operation (indoor de-icing).
3. To reduce the freeze-up operation (indoor de-icing) frequency it is recommended to install the outdoor unit in a location not exposed to wind.
4. Operation range is valid in case direct expansion indoor units are used. In case special indoor units are used, (eg. Hydrobox), refer to technical specs of dedicated unit.

3D079544



These products are not within the scope of the Eurovent certification program

The present leaflet is drawn up by way of information only and does not constitute an offer binding upon Daikin Europe N.V.. Daikin Europe N.V. has compiled the content of this leaflet to the best of its knowledge. No express or implied warranty is given for the completeness, accuracy, reliability or fitness for particular purpose of its content and the products and services presented therein. Specifications are subject to change without prior notice. Daikin Europe N.V. explicitly rejects any liability for any direct or indirect damage, in the broadest sense, arising from or related to the use and/or interpretation of this leaflet. All content is copyrighted by Daikin Europe N.V.

BARCODE

Daikin products are distributed by: