

# **FXL-L / FXN-L**

## **Floor Standing Type / Concealed Floor Standing Type**

1. Features .....	294
2. Specifications .....	295
2.1 FXL .....	295
2.2 FXN .....	297
3. Dimensions .....	299
3.1 FXL .....	299
3.2 FXN .....	302
4. Piping Diagrams .....	305
5. Wiring Diagrams .....	306
6. Capacity Tables .....	307
6.1 Cooling Capacity .....	307
6.2 Heating Capacity .....	309
7. Electric Characteristics .....	311
8. Sound Levels .....	312
9. Installation .....	314
10. Accessories .....	316

# 1. Features

Efficient for perimeter zone airconditioning.

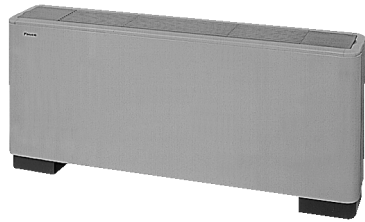

FXL-L

Can be built into pericounter

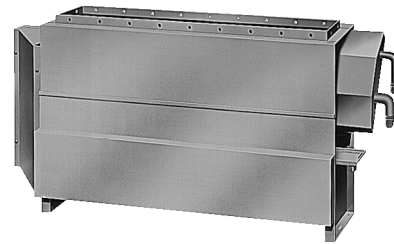

FXN-L

## (1) New round-shape adds the gentle feeling to office environment.

- Mild color is applied to the discharge grille and the bottom frame.
- The slimming top plate ensures elegance in dynamics.

## (2) Improvement on the installation

- The piping connection work is facilitated drastically.

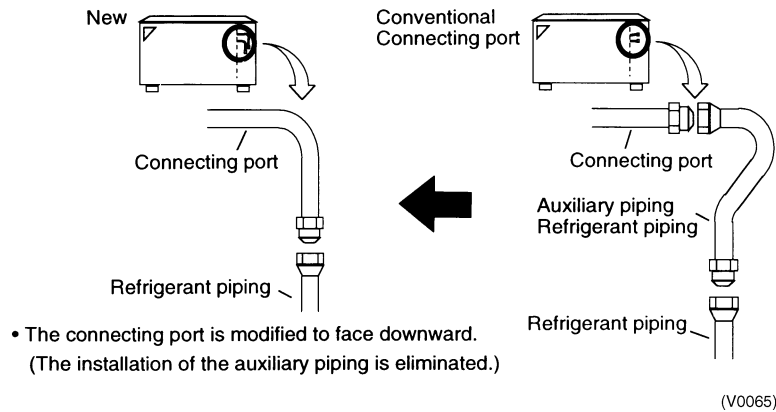

## (3) Easy maintenance

When the unit is hung on the wall, it is easy to clean the floor. (Exposed type)

- The maintenance of the discharge grille is improved.
- The interval of filter cleaning is prolonged.

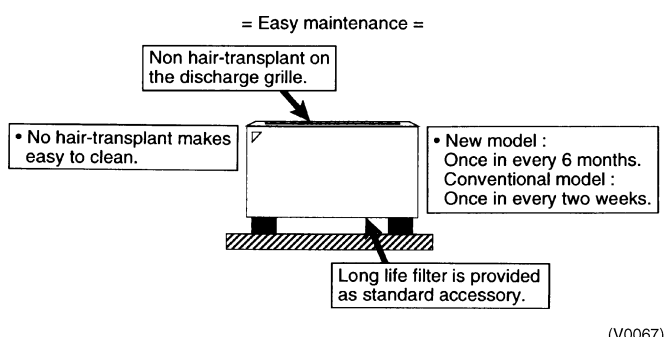
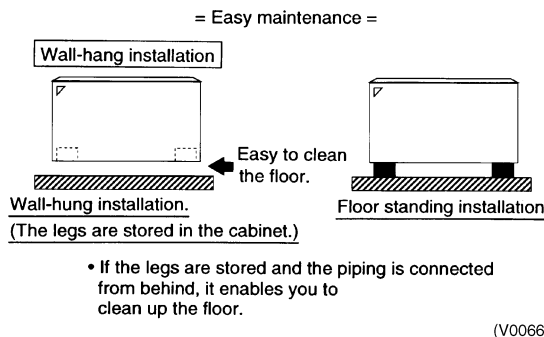

## (4) Environment friendly packing

- No Styrofoam is used.
- Material saving packing.

## 2. Specifications

### 2.1 FXL

#### Floor Standing Type

Model			FXL20LVE	FXL25LVE	FXL32LVE
★1 Cooling Capacity (19.5°CWB)	kcal/h		2,000	2,500	3,150
	Btu/h		7,900	9,900	12,500
	kW		2.3	2.9	3.7
★2 Cooling Capacity (19.0°CWB)	kW		2.2	2.8	3.6
★3 Heating Capacity	kcal/h		2,200	2,800	3,400
	Btu/h		8,500	10,900	13,600
	kW		2.5	3.2	4.0
Casing Color			Ivory White (5Y7.5/1)	Ivory White (5Y7.5/1)	Ivory White (5Y7.5/1)
Dimensions: (HxWxD)		mm	600x1,000x222	600x1,000x222	600x1,140x222
Coil (Cross Fin Coil)	RowsxStagesxFin Pitch	mm	3x14x1.5	3x14x1.5	3x14x1.5
	Face Area	m <sup>2</sup>	0.159	0.159	0.200
Fan	Model		D14B20	D14B20	D14B13
	Type		Sirocco Fan	Sirocco Fan	Sirocco Fan
	Motor Output x Number of Units	W	15x1	15x1	25x1
	Air Flow Rate (H/L)	m <sup>3</sup> /min	7/6	7/6	8/6
		cfm	247/212	247/212	282/212
Drive		Direct Drive	Direct Drive	Direct Drive	
Temperature Control			Microprocessor Thermostat for Cooling and Heating	Microprocessor Thermostat for Cooling and Heating	Microprocessor Thermostat for Cooling and Heating
Sound Absorbing Thermal Insulation Material			Glass Fiber/ Urethane Foam	Glass Fiber/ Urethane Foam	Glass Fiber/ Urethane Foam
Air Filter			Resin Net (with Mold Resistant)	Resin Net (with Mold Resistant)	Resin Net (with Mold Resistant)
Piping Connections	Liquid Pipes	mm	φ6.4 (Flare Connection)	φ6.4 (Flare Connection)	φ6.4 (Flare Connection)
	Gas Pipes	mm	φ12.7 (Flare Connection)	φ12.7 (Flare Connection)	φ12.7 (Flare Connection)
	Drain Pipe	mm	φ21 O.D (Vinyl Chloride)	φ21 O.D (Vinyl Chloride)	φ21 O.D (Vinyl Chloride)
Machine Weight		kg	25	25	30
★5 Sound Level (H/L)		dBA	35/32	35/32	35/32
Safety Devices			Fuse, Thermal Protector for Fan Motor	Fuse, Thermal Protector for Fan Motor	Fuse, Thermal Protector for Fan Motor
Refrigerant Control			Electronic Expansion Valve	Electronic Expansion Valve	Electronic Expansion Valve
Connectable Outdoor Unit			R22 : K Series R407C : K or L Series	R22 : K Series R407C : K or L Series	R22 : K Series R407C : K or L Series
Standard Accessories			Operation Manual, Installation Manual, Insulation for Fitting, Drain Hose, Clamps, Screws, Washers, Level Adjustment Screw.	Operation Manual, Installation Manual, Insulation for Fitting, Drain Hose, Clamps, Screws, Washers, Level Adjustment Screw.	Operation Manual, Installation Manual, Insulation for Fitting, Drain Hose, Clamps, Screws, Washers, Level Adjustment Screw.
Drawing No.			3D034576A		

#### Notes:

- ★1 Indoor temp. : 27°CDB, 19.5°CWB / outdoor temp.: 35°CDB / Equivalent piping length: 7.5m, level difference: 0m.
- ★2 Indoor temp. : 27°CDB, 19.0°CWB / outdoor temp.: 35°CDB / Equivalent piping length: 7.5m, level difference: 0m.
- ★3 Indoor temp. : 20°CDB / outdoor temp.: 7°CDB, 6°CWB / Equivalent piping length; 7.5m, level difference; 0m. (Heat pump only)
  - 4 Capacities are net, including a deduction for cooling (an addition for heating) for indoor fan motor heat.
- ★5 Anechoic chamber conversion value, measured at a point 1.5 m in front of the unit at a height of 1.5 m. During actual operation, these values are normally somewhat higher as a result of ambient conditions.
- 6 Refer to page 311 for Fan Motor Input.

Conversion Formulae
kcal/h=kWx860
Btu/h=kWx3414
cfm=m <sup>3</sup> /minx35.3

Floor Standing Type

Model			FXL40LVE	FXL50LVE	FXL63LVE
★1 Cooling Capacity (19.5°CWB)		kcal/h	4,000	5,000	6,300
		Btu/h	15,900	19,900	25,000
		kW	4.7	5.8	7.3
★2 Cooling Capacity (19.0°CWB)		kW	4.5	5.6	7.1
★3 Heating Capacity		kcal/h	4,300	5,400	6,900
		Btu/h	17,000	21,500	27,300
		kW	5.0	6.3	8.0
Casing Color			Ivory White (5Y7.5/1)	Ivory White (5Y7.5/1)	Ivory White (5Y7.5/1)
Dimensions: (H×W×D)		mm	600×1,140×222	600×1,420×222	600×1,420×222
Coil (Cross Fin Coil)	Rows×Stages×Fin Pitch	mm	3×14×1.5	3×14×1.5	3×14×1.5
	Face Area	m <sup>2</sup>	0.200	0.282	0.282
Fan	Model		2D14B13	2D14B20	2D14B20
	Type		Sirocco Fan	Sirocco Fan	Sirocco Fan
	Motor Output × Number of Units	W	25×1	35×1	35×1
	Air Flow Rate (H/L)	m <sup>3</sup> /min	11/8.5	14/11	16/12
		cfm	388/300	494/388	565/424
Drive			Direct Drive	Direct Drive	Direct Drive
Temperature Control			Microprocessor Thermostat for Cooling and Heating	Microprocessor Thermostat for Cooling and Heating	Microprocessor Thermostat for Cooling and Heating
Sound Absorbing Thermal Insulation Material			Glass Fiber/ Urethane Foam	Glass Fiber/ Urethane Foam	Glass Fiber/ Urethane Foam
Air Filter			Resin Net (with Mold Resistant)	Resin Net (with Mold Resistant)	Resin Net (with Mold Resistant)
Piping Connections	Liquid Pipes	mm	φ6.4 (Flare Connection)	φ9.5 (Flare Connection)	φ9.5 (Flare Connection)
	Gas Pipes	mm	φ12.7 (Flare Connection)	φ15.9 (Flare Connection)	φ15.9 (Flare Connection)
	Drain Pipe	mm	φ21 O.D (Vinyl Chloride)	φ21 O.D (Vinyl Chloride)	φ21 O.D (Vinyl Chloride)
Machine Weight		kg	30	36	36
★5 Sound Level (H/L)		dBA	38/33	39/34	40/35
Safety Devices			Fuse, Thermal Protector for Fan Motor	Fuse, Thermal Protector for Fan Motor	Fuse, Thermal Protector for Fan Motor
Refrigerant Control			Electronic Expansion Valve	Electronic Expansion Valve	Electronic Expansion Valve
Connectable Outdoor Unit			R22 : K Series R407C : K or L Series	R22 : K Series R407C : K or L Series	R22 : K Series R407C : K or L Series
Standard Accessories			Operation Manual, Installation Manual, Insulation for Fitting, Drain Hose, Clamps, Screws, Washers, Level Adjustment Screw.	Operation Manual, Installation Manual, Insulation for Fitting, Drain Hose, Clamps, Screws, Washers, Level Adjustment Screw.	Operation Manual, Installation Manual, Insulation for Fitting, Drain Hose, Clamps, Screws, Washers, Level Adjustment Screw.
Drawing No.			3D034576A		

Notes:

- ★1 Indoor temp. : 27°CDB, 19.5°CWB / outdoor temp.: 35°CDB / Equivalent piping length: 7.5m, level difference: 0m.
- ★2 Indoor temp. : 27°CDB, 19.0°CWB / outdoor temp.: 35°CDB / Equivalent piping length: 7.5m, level difference: 0m.
- ★3 Indoor temp. : 20°CDB / outdoor temp.: 7°CDB, 6°CWB / Equivalent piping length; 7.5m, level difference; 0m. (Heat pump only)
  - 4 Capacities are net, including a deduction for cooling (an addition for heating) for indoor fan motor heat.
- ★5 Anechoic chamber conversion value, measured at a point 1.5 m in front of the unit at a height of 1.5 m. During actual operation, these values are normally somewhat higher as a result of ambient conditions.
- 6 Refer to page 311 for Fan Motor Input.

Conversion Formulae
kcal/h=kW×860
Btu/h=kW×3414
cfm=m <sup>3</sup> /min×35.3

## 2.2 FXN

### Concealed Floor Standing Type

Model		FXN20LVE	FXN25LVE	FXN32LVE	
★1 Cooling Capacity (19.5°CWB)	kcal/h	2,000	2,500	3,150	
	Btu/h	7,900	9,900	12,500	
	kW	2.3	2.9	3.7	
★2 Cooling Capacity (19.0°CWB)	kW	2.2	2.8	3.6	
★3 Heating Capacity	kcal/h	2,200	2,800	3,400	
	Btu/h	8,500	10,900	13,600	
	kW	2.5	3.2	4.0	
Casing Color		Galvanized Steel Plate	Galvanized Steel Plate	Galvanized Steel Plate	
Dimensions: (HxWxD)		mm 610x930x220	610x930x220	610x1,070x220	
Coil (Cross Fin Coil)	RowsxStagesxFin Pitch	mm 3x14x1.5	3x14x1.5	3x14x1.5	
	Face Area	m <sup>2</sup> 0.159	0.159	0.200	
Fan	Model	D14B20	D14B20	2D14B13	
	Type	Sirocco Fan	Sirocco Fan	Sirocco Fan	
	Motor Output x Number of Units	W 15x1	15x1	25x1	
	Air Flow Rate (H/L)	m <sup>3</sup> /min	7/6	7/6	8/6
		cfm	247/212	247/212	282/212
Drive	Direct Drive	Direct Drive	Direct Drive		
Temperature Control		Microprocessor Thermostat for Cooling and Heating	Microprocessor Thermostat for Cooling and Heating	Microprocessor Thermostat for Cooling and Heating	
Sound Absorbing Thermal Insulation Material		Glass Fiber/ Urethane Foam	Glass Fiber/ Urethane Foam	Glass Fiber/ Urethane Foam	
Air Filter		Resin Net (with Mold Resistant)	Resin Net (with Mold Resistant)	Resin Net (with Mold Resistant)	
Piping Connections	Liquid Pipes	mm φ6.4 (Flare Connection)	φ6.4 (Flare Connection)	φ6.4 (Flare Connection)	
	Gas Pipes	mm φ12.7 (Flare Connection)	φ12.7 (Flare Connection)	φ12.7 (Flare Connection)	
	Drain Pipe	mm φ21 O.D (Vinyl Chloride)	φ21 O.D (Vinyl Chloride)	φ21 O.D (Vinyl Chloride)	
Machine Weight	kg	19	19	23	
★5 Sound Level (H/L)	dBA	35/32	35/32	35/32	
Safety Devices		Fuse, Thermal Protector for Fan Motor	Fuse, Thermal Protector for Fan Motor	Fuse, Thermal Protector for Fan Motor	
Refrigerant Control		Electronic Expansion Valve	Electronic Expansion Valve	Electronic Expansion Valve	
Connectable Outdoor Unit		R22 : K Series R407C : K or L Series	R22 : K Series R407C : K or L Series	R22 : K Series R407C : K or L Series	
Standard Accessories		Operation Manual, Installation Manual, Insulation for Fitting, Drain Hose, Clamps, Screws, Washers, Level Adjustment Screw.	Operation Manual, Installation Manual, Insulation for Fitting, Drain Hose, Clamps, Screws, Washers, Level Adjustment Screw.	Operation Manual, Installation Manual, Insulation for Fitting, Drain Hose, Clamps, Screws, Washers, Level Adjustment Screw.	
Drawing No.		3D034577A			

**Notes:**

- ★1 Indoor temp. : 27°CDB, 19.5°CWB / outdoor temp.: 35°CDB / Equivalent piping length: 7.5m, level difference: 0m.
- ★2 Indoor temp. : 27°CDB, 19.0°CWB / outdoor temp.: 35°CDB / Equivalent piping length: 7.5m, level difference: 0m.
- ★3 Indoor temp. : 20°CDB / outdoor temp.: 7°CDB, 6°CWB / Equivalent piping length; 7.5m, level difference; 0m. (Heat pump only)
  - 4 Capacities are net, including a deduction for cooling (an addition for heating) for indoor fan motor heat.
- ★5 Anechoic chamber conversion value, measured at a point 1.5 m in front of the unit at a height of 1.5 m. During actual operation, these values are normally somewhat higher as a result of ambient conditions.
- 6 Refer to page 311 for Fan Motor Input.

Conversion Formulae
kcal/h=kWx860
Btu/h=kWx3414
cfm=m <sup>3</sup> /minx35.3



**Concealed Floor Standing Type**

Model			FXN40LVE	FXN50LVE	FXN63LVE
★1 Cooling Capacity (19.5°CWB)		kcal/h	4,000	5,000	6,300
		Btu/h	15,900	19,900	25,000
		kW	4.7	5.8	7.3
★2 Cooling Capacity (19.0°CWB)		kW	4.5	5.6	7.1
★3 Heating Capacity		kcal/h	4,300	5,400	6,900
		Btu/h	17,000	21,500	27,300
		kW	5.0	6.3	8.0
Casing Color			Galvanized Steel Plate	Galvanized Steel Plate	Galvanized Steel Plate
Dimensions: (HxWxD)		mm	610x1,070x220	610x1,350x220	610x1,350x220
Coil (Cross Fin Coil)	RowsxStagesxFin Pitch	mm	3x14x1.5	3x14x1.5	3x14x1.5
	Face Area	m <sup>2</sup>	0.200	0.282	0.282
Fan	Model		2D14B13	2D14B20	2D14B20
	Type		Sirocco Fan	Sirocco Fan	Sirocco Fan
	Motor Output x Number of Units	W	25x1	35x1	35x1
	Air Flow Rate (H/L)	m <sup>3</sup> /min	11/8.5	14/11	16/12
		cfm	388/300	494/388	565/424
Drive			Direct Drive	Direct Drive	Direct Drive
Temperature Control			Microprocessor Thermostat for Cooling and Heating	Microprocessor Thermostat for Cooling and Heating	Microprocessor Thermostat for Cooling and Heating
Sound Absorbing Thermal Insulation Material			Glass Fiber / Urethane Foam	Glass Fiber / Urethane Foam	Glass Fiber / Urethane Foam
Air Filter			Resin Net (with Mold Resistant)	Resin Net (with Mold Resistant)	Resin Net (with Mold Resistant)
Piping Connections	Liquid Pipes	mm	φ6.4 (Flare Connection)	φ9.5 (Flare Connection)	φ9.5 (Flare Connection)
	Gas Pipes	mm	φ12.7 (Flare Connection)	φ15.9 (Flare Connection)	φ15.9 (Flare Connection)
	Drain Pipe	mm	φ21 O.D (Vinyl Chloride)	φ21 O.D (Vinyl Chloride)	φ21 O.D (Vinyl Chloride)
Machine Weight		kg	23	27	27
★5 Sound Level (H/L)		dBA	38/33	39/34	40/35
Safety Devices			Fuse, Thermal Protector for Fan Motor	Fuse, Thermal Protector for Fan Motor	Fuse, Thermal Protector for Fan Motor
Refrigerant Control			Electronic Expansion Valve	Electronic Expansion Valve	Electronic Expansion Valve
Connectable Outdoor Unit			R22 : K Series R407C : K or L Series	R22 : K Series R407C : K or L Series	R22 : K Series R407C : K or L Series
Standard Accessories			Operation Manual, Installation Manual, Insulation for Fitting, Drain Hose, Clamps, Screws, Washers, Level Adjustment Screw.	Operation Manual, Installation Manual, Insulation for Fitting, Drain Hose, Clamps, Screws, Washers, Level Adjustment Screw.	Operation Manual, Installation Manual, Insulation for Fitting, Drain Hose, Clamps, Screws, Washers, Level Adjustment Screw.
Drawing No.			3D034577A		

**Notes:**

- ★1 Indoor temp. : 27°CDB, 19.5°CWB / outdoor temp.: 35°CDB / Equivalent piping length: 7.5m, level difference: 0m.
- ★2 Indoor temp. : 27°CDB, 19.0°CWB / outdoor temp.: 35°CDB / Equivalent piping length: 7.5m, level difference: 0m.
- ★3 Indoor temp. : 20°CDB / outdoor temp.: 7°CDB, 6°CWB / Equivalent piping length; 7.5m, level difference; 0m. (Heat pump only)
  - 4 Capacities are net, including a deduction for cooling (an addition for heating) for indoor fan motor heat.
- ★5 Anechoic chamber conversion value, measured at a point 1.5 m in front of the unit at a height of 1.5 m. During actual operation, these values are normally somewhat higher as a result of ambient conditions.
- 6 Refer to page 311 for Fan Motor Input.

Conversion Formulae
kcal/h=kWx860
Btu/h=kWx3414
cfm=m <sup>3</sup> /minx35.3

### 3. Dimensions

#### 3.1 FXL

FXL20L

FXL25L

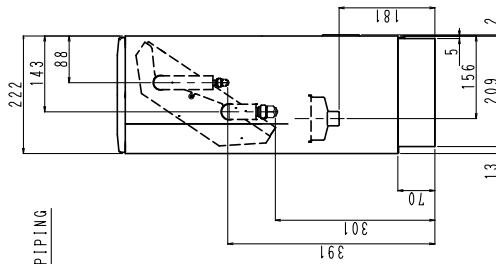
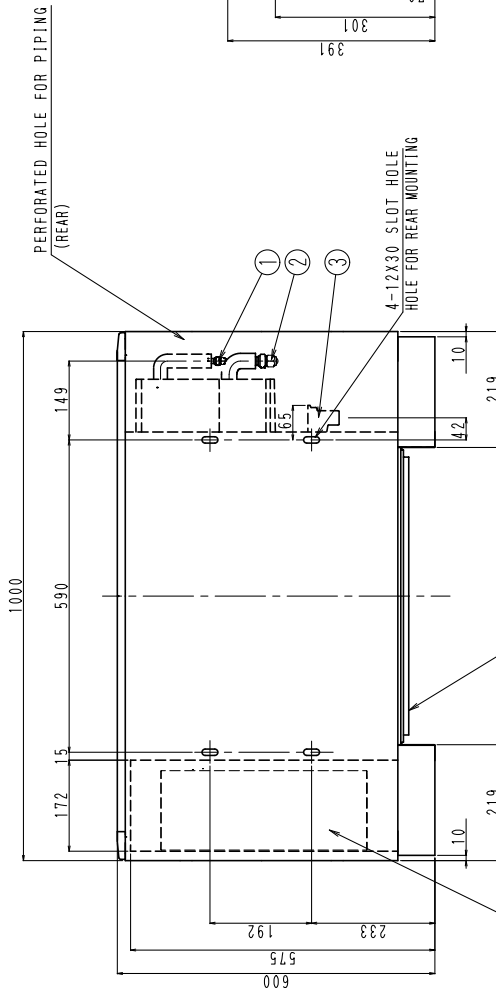
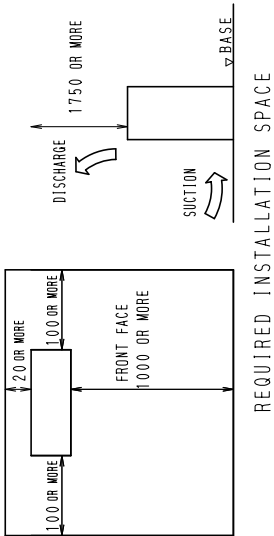

NOTE)  
1. LOCATION OF UNIT'S NAME PLATE:  
OUTSIDE SURFACE OF RIGHT SIDE PLATE.

NUMBER	NAME	DESCRIPTION
1	LIQUID PIPE CONNECTION PORT	φ 6.4 FLARE CONNECTION
2	GAS PIPE CONNECTION PORT	φ 12.7 FLARE CONNECTION
3	DRAIN PIPE CONNECTION PORT	O. D. 21
4	SWITCH BOX	
5	AIR FILTER	

Unit (mm)

3D007899D

FXL32L  
FXL40L

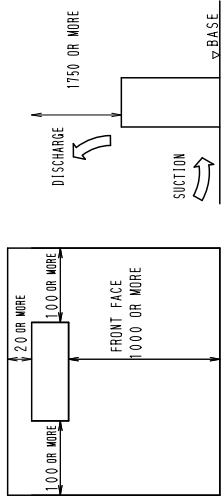

REQUIRED INSTALLATION SPACE

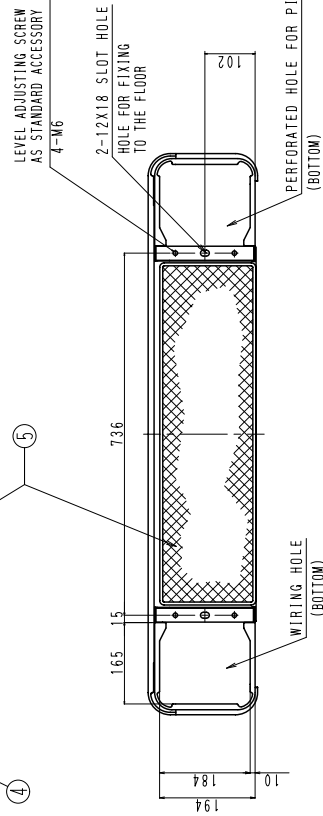
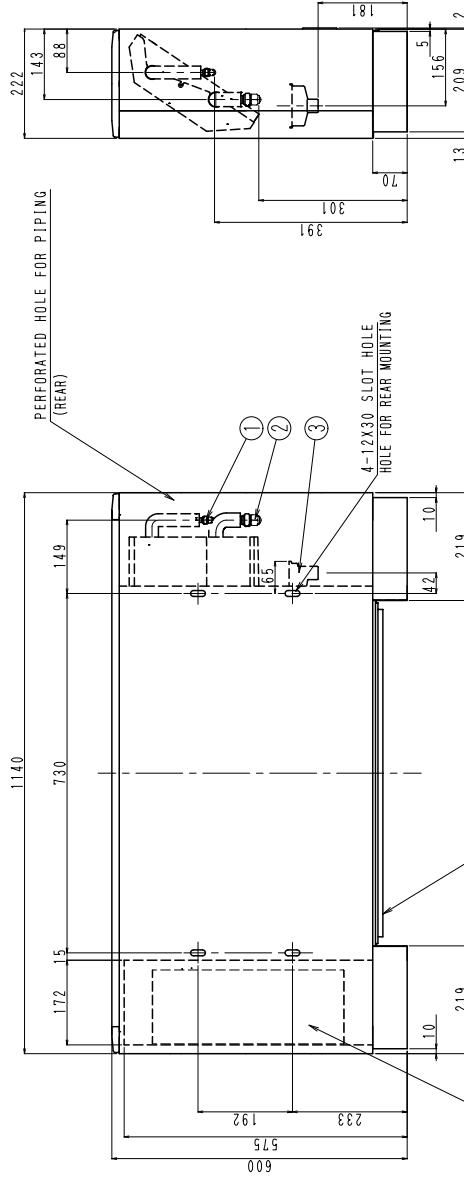
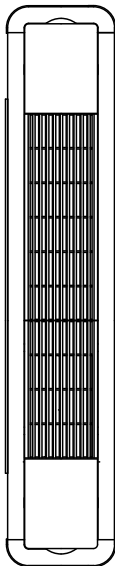

NOTE)  
1. LOCATION OF UNIT'S NAME PLATE:  
OUTSIDE SURFACE OF RIGHT SIDE PLATE.

NUMBER	NAME	DESCRIPTION
1	LIQUID PIPE CONNECTION PORT	φ6.4 FLARE CONNECTION
2	GAS PIPE CONNECTION PORT	φ12.7 FLARE CONNECTION
3	DRAIN PIPE CONNECTION PORT	0, D, 21
4	SWITCH BOX	
	AIR FILTER	

Unit (mm)

3D007926D



FXL50L  
FXL63L

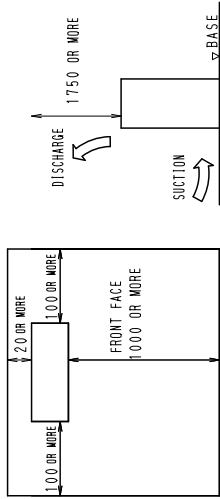

REQUIRED INSTALLATION SPACE

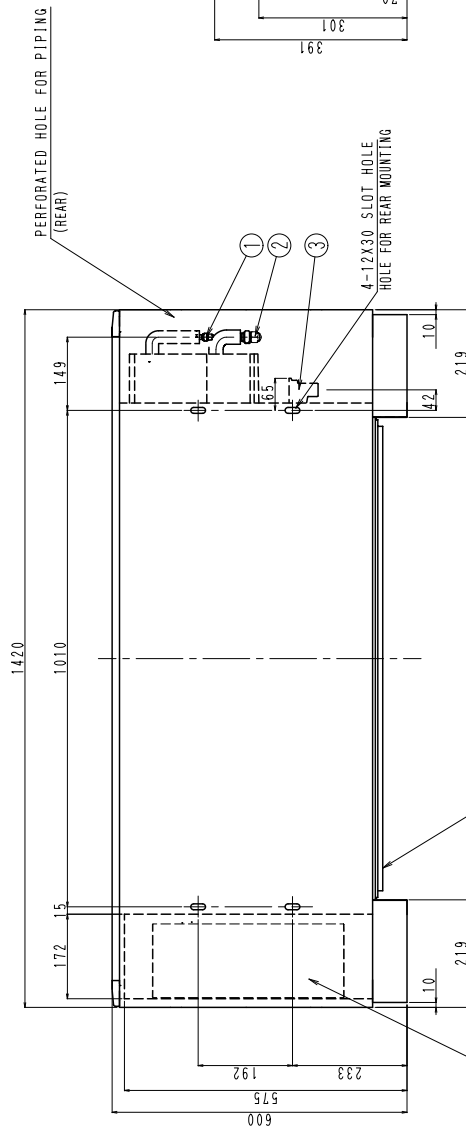
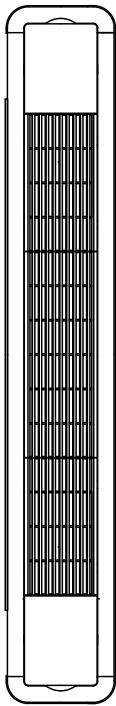

NOTE)  
1, LOCATION OF UNIT'S NAME PLATE:  
OUTSIDE SURFACE OF RIGHT SIDE PLATE.

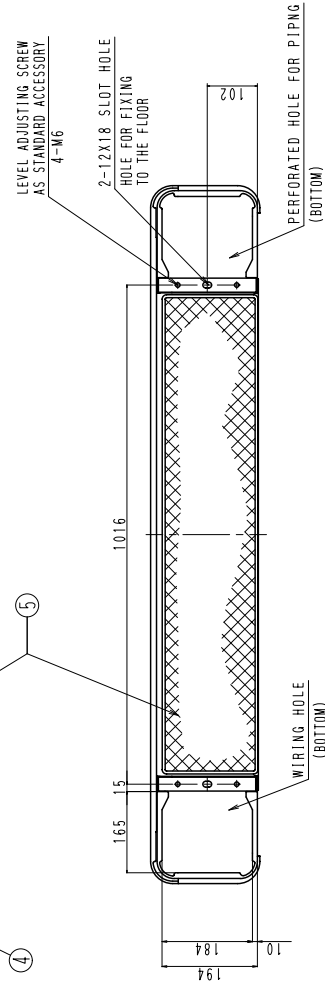

Unit (mm)

NUMBER	NAME	DESCRIPTION
1	LIQUID PIPE CONNECTION PORT	φ9.5 FLARE CONNECTION
2	GAS PIPE CONNECTION PORT	φ15.9 FLARE CONNECTION
3	DRAIN PIPE CONNECTION PORT	O. D. 21
4	SWITCH BOX	
5	AIR FILTER	

3D007927D

### 3.2 FXN

FXN20L  
FXN25L

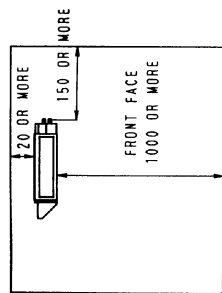

REQUIRED INSTALLATION SPACE

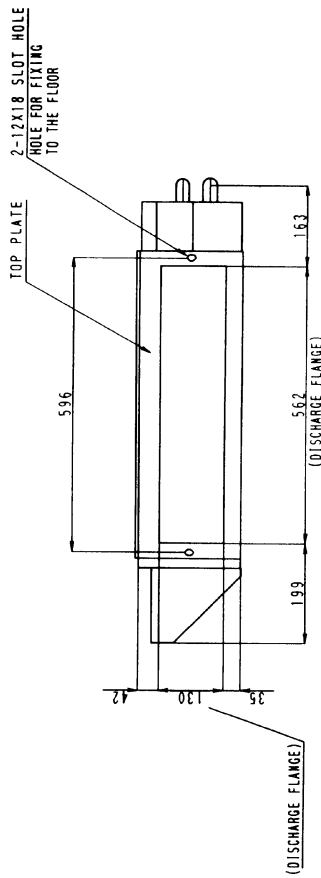

(DISCHARGE FLANGE)

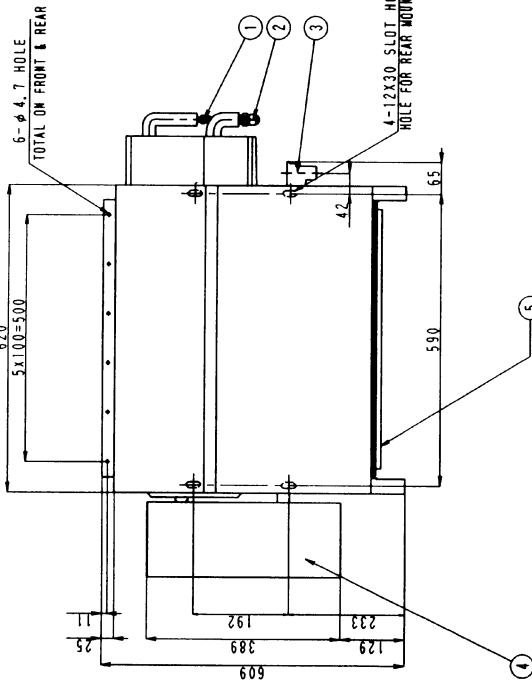
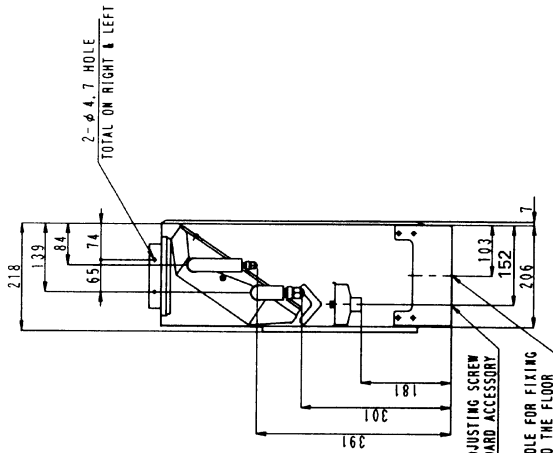

NOTE)

1. LOCATION OF UNIT'S NAME PLATE :  
THE RIGHT LOWER CORNER OF FRONT PLATE

NUMBER	NAME	DESCRIPTION
1	LIQUID PIPE CONNECTION PORT	φ6.4 FLARE CONNECTION
2	GAS PIPE CONNECTION PORT	φ12.7 FLARE CONNECTION
3	DRAIN PIPE CONNECTION PORT	0. D. 21
4	SWITCH BOX	
5	AIR FILTER	

Unit (mm)

3D007928D

FXN32L  
FXN40L

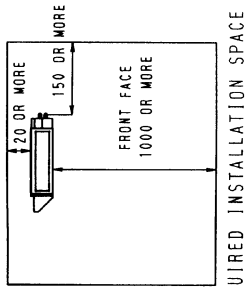

REQUIRED INSTALLATION SPACE

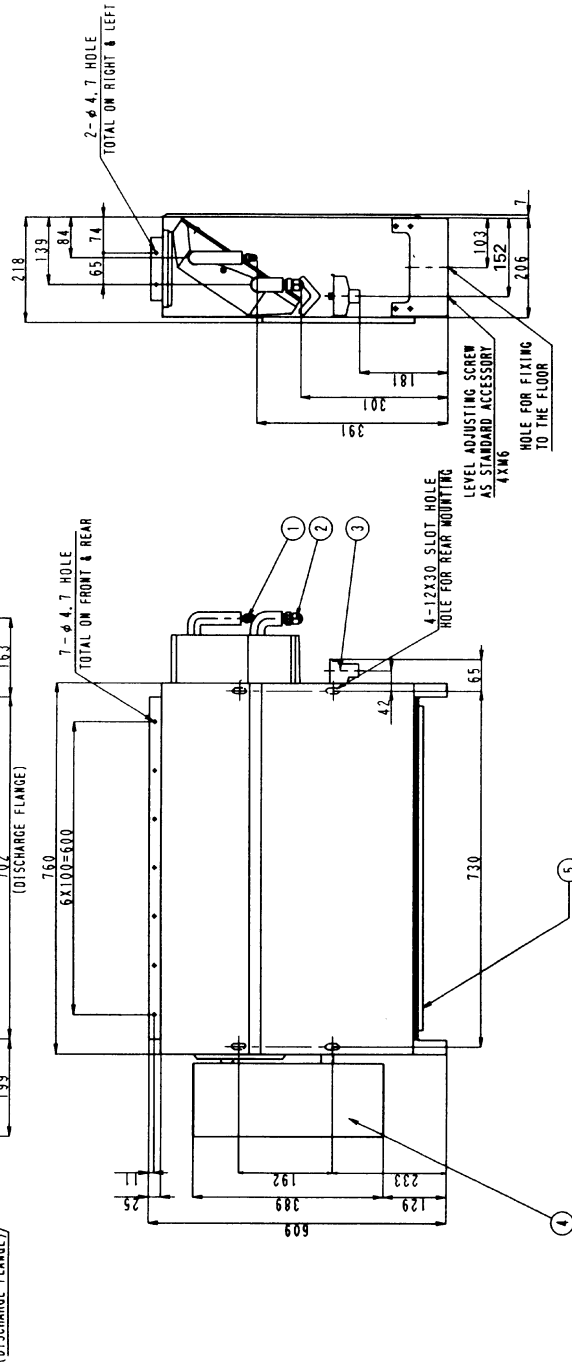
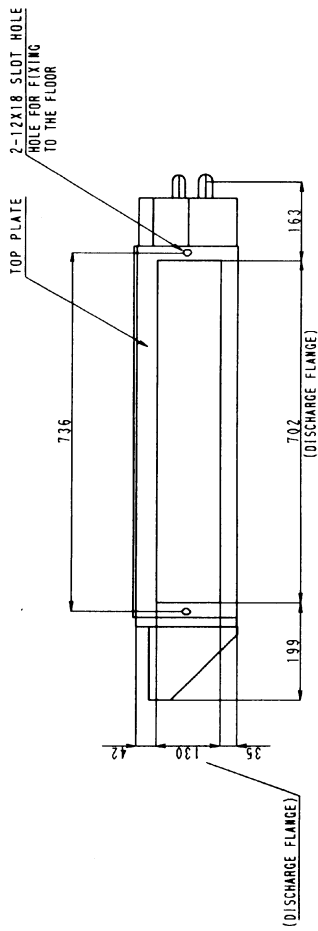

NOTE)  
1. LOCATION OF UNIT'S NAME PLATE :  
THE RIGHT LOWER CORNER OF FRONT PLATE

NUMBER	NAME	DESCRIPTION
1	LIQUID PIPE CONNECTION PORT	φ6.4 FLARE CONNECTION
2	GAS PIPE CONNECTION PORT	φ12.7 FLARE CONNECTION
3	DRAIN PIPE CONNECTION PORT	O. D. 21
4	SWITCH BOX	
5	AIR FILTER	

Unit (mm)

3D007929D

FXN50L  
FXN63L

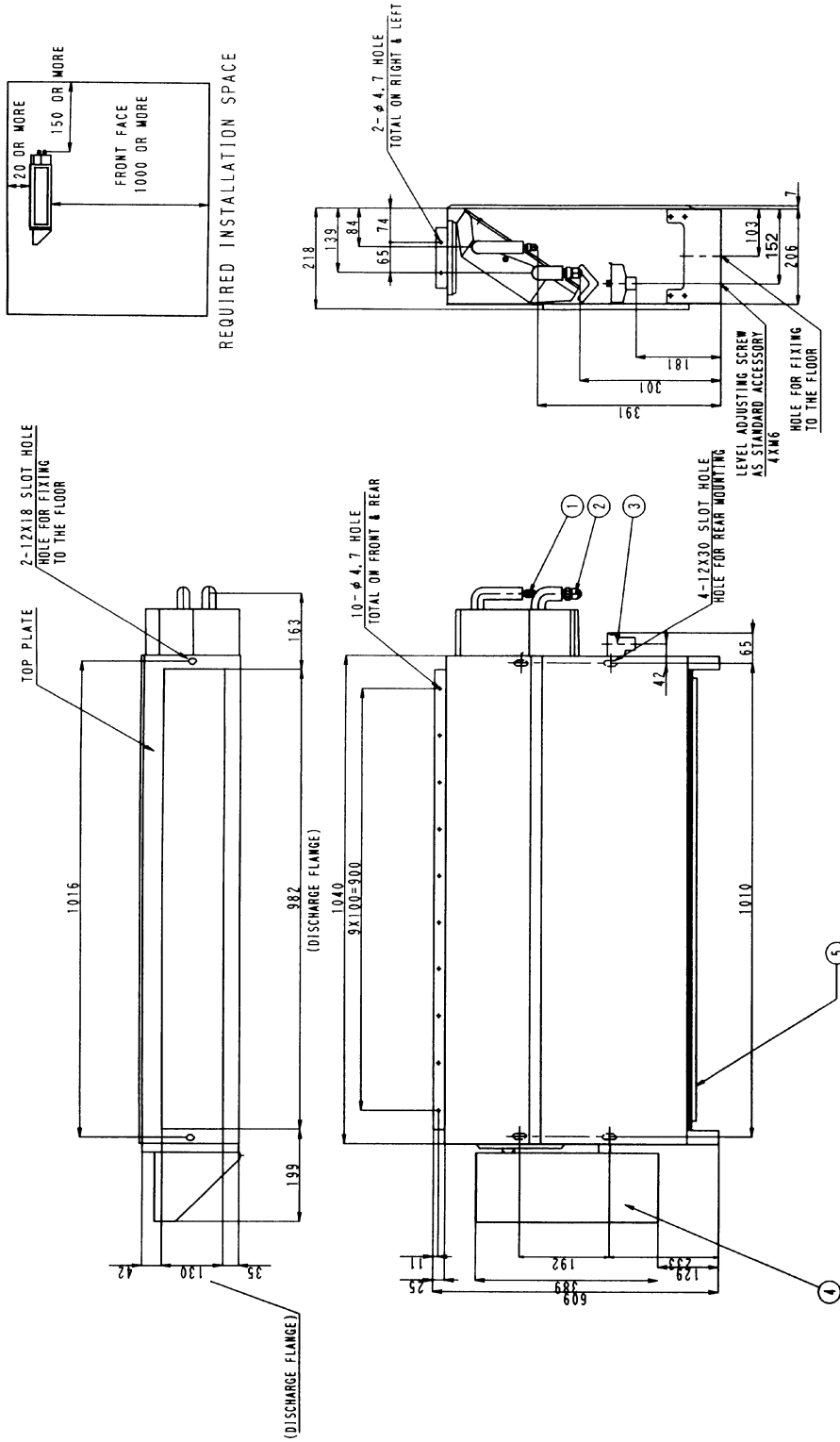

NOTE)  
1. LOCATION OF UNIT'S NAME PLATE :  
THE RIGHT LOWER CORNER OF FRONT PLATE

NUMBER	NAME	DESCRIPTION
1	LIQUID PIPE CONNECTION PORT	φ9.5 FLARE CONNECTION
2	GAS PIPE CONNECTION PORT	φ15.9 FLARE CONNECTION
3	DRAIN PIPE CONNECTION PORT	O. D. 21
4	SWITCH BOX	
5	AIR FILTER	

Unit (mm)

3D007980D

# 4. Piping Diagrams

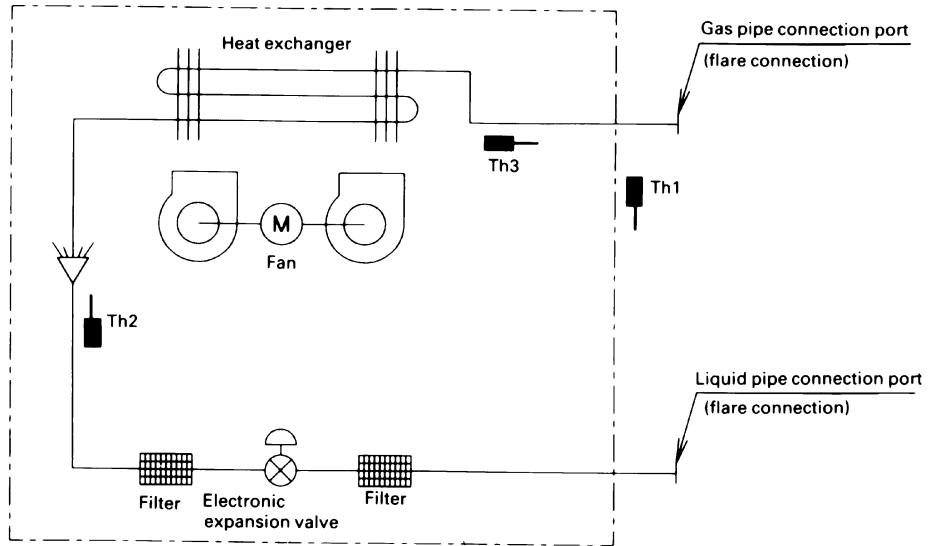

Th1: Thermister for suction air temp.  
 Th2: Thermister for liquid line temp.  
 Th3: Thermister for gas line temp.

4D034245

### ■ Refrigerant pipe connection port diameters

(mm)

Model	Gas	Liquid
FXL20L / 25L / 32L / 40L FXN20L / 25L / 32L / 40L	φ12.7	φ6.4
FXL50L / 63L FXN50L / 63L	φ15.9	φ9.5

# 5. Wiring Diagrams

FXL 20L / 25L / 32L / 40L / 50L / 63LVE  
 FXN 20L / 25L / 32L / 40L / 50L / 63LVE

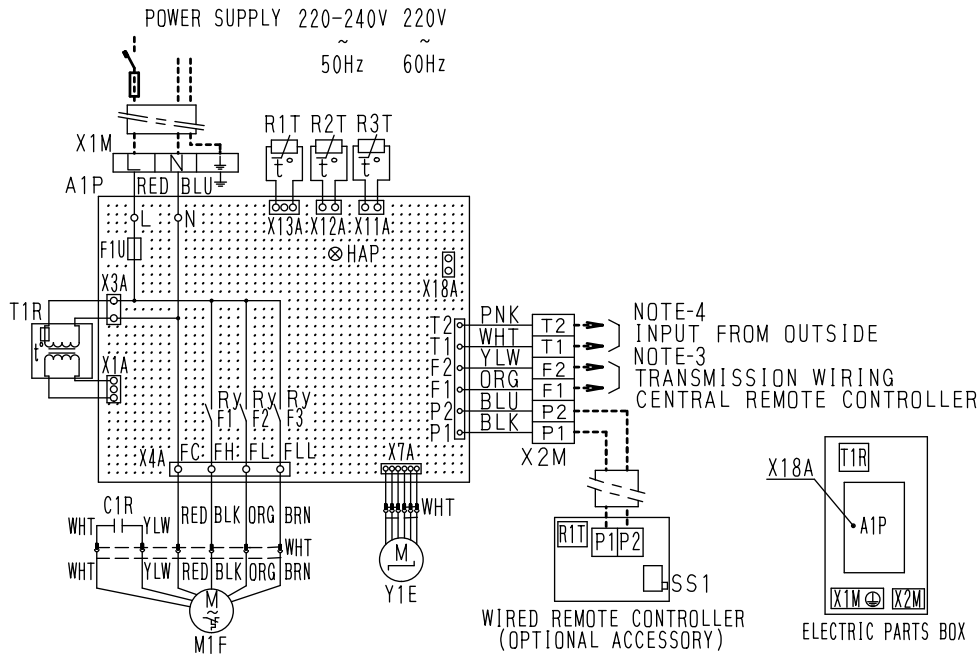

NOTES)

1. □□□□:TERMINAL, □○□, □□□:CONNECTOR, ○-○:WIRE CLAMP
2. ----:FIELD WIRING
3. IN CASE USING CENTRAL REMOTE CONTROLLER, CONNECT IT TO THE UNIT IN ACCORDANCE WITH THE ATTACHED INSTRUCTION MANUAL,
4. WHEN CONNECTING THE INPUT WIRES FROM OUTSIDE, FORCED OFF OR ON/OFF CONTROL OPERATION CAN BE SELECTED BY REMOTE CONTROLLER, IN DETAILS, REFER TO THE INSTALLATION MANUAL ATTACHED THE UNIT.
5. SYMBOLS SHOW AS FOLLOWS, (PNK:PINK WHT:WHITE YLW:YELLOW ORG:ORANGE BLU:BLUE BLK:BLACK RED:RED BRN:BROWN)
6. USE COPPER CONDUCTORS ONLY,

A1P	PRINTED CIRCUIT BOARD	X2M	TERMINAL STRIP(CONTROL)
C1R	CAPACITOR (M1F)	Y1E	ELECTRONIC EXPANSION VALVE
F1U	FUSE(250V,10A,Ⓟ) OR F10T 250V	Wired Remote Controller	Wired Remote Controller
HAP	LIGHT EMITTING DIODE (SERVICE MONITOR-GREEN)	R1T	THERMISTOR(AIR)
M1F	MOTOR (INDOOR FAN)	SS1	SELECTOR SWITCH(MAIN/SUB)
Q1F	THERMO SWITCH (M1F EMBEDDED)	X18A	CONNECTOR FOR OPTIONAL PARTS CONNECTOR WIRING ADAPTOR FOR ELECTRICAL APPENDICES)
R1T	THERMISTOR(AIR)		
R2T-3T	THERMISTOR(COIL)		
RyF1-3	MAGNETIC RELAY(M1F)		
T1R	TRANSFORMER(220-240V/22V)		
X1M	TERMINAL STRIP(POWER)		
	L-RED		N-BLUE

# 6. Capacity Tables

## 6.1 Cooling Capacity

FXL – L / FXN – L

Unit Size	Outdoor air temp. °CDB	Cooling capacity													
		Indoor air temp.													
		14.0°CWB		16.0°CWB		18.0°CWB		19.0°CWB		20.0°CWB		22.0°CWB		24.0°CWB	
		20°CDB		23°CDB		26°CDB		27°CDB		28°CDB		30°CDB		32°CDB	
		TC	SHC	TC	SHC	TC	SHC	TC	SHC	TC	SHC	TC	SHC	TC	SHC
20	10.0	1.5	1.3	1.8	1.5	2.1	1.7	2.2	1.7	2.3	1.8	2.6	1.8	2.9	1.8
	12.0	1.5	1.3	1.8	1.5	2.1	1.7	2.2	1.7	2.3	1.8	2.6	1.8	2.9	1.8
	14.0	1.5	1.3	1.8	1.5	2.1	1.7	2.2	1.7	2.3	1.8	2.6	1.8	2.9	1.8
	16.0	1.5	1.3	1.8	1.5	2.1	1.7	2.2	1.7	2.3	1.8	2.6	1.8	2.9	1.8
	18.0	1.5	1.3	1.8	1.5	2.1	1.7	2.2	1.7	2.3	1.8	2.6	1.8	2.9	1.8
	20.0	1.5	1.3	1.8	1.5	2.1	1.7	2.2	1.7	2.3	1.8	2.6	1.8	2.9	1.8
	21.0	1.5	1.3	1.8	1.5	2.1	1.7	2.2	1.7	2.3	1.8	2.6	1.8	2.9	1.8
	23.0	1.5	1.3	1.8	1.5	2.1	1.7	2.2	1.7	2.3	1.8	2.6	1.8	2.9	1.8
	25.0	1.5	1.3	1.8	1.5	2.1	1.7	2.2	1.7	2.3	1.8	2.6	1.8	2.8	1.8
	27.0	1.5	1.3	1.8	1.5	2.1	1.7	2.2	1.7	2.3	1.8	2.6	1.8	2.8	1.7
	29.0	1.5	1.3	1.8	1.5	2.1	1.7	2.2	1.7	2.3	1.8	2.6	1.8	2.7	1.7
	31.0	1.5	1.3	1.8	1.5	2.1	1.7	2.2	1.7	2.3	1.8	2.5	1.8	2.7	1.7
	33.0	1.5	1.3	1.8	1.5	2.1	1.7	2.2	1.7	2.3	1.8	2.5	1.7	2.6	1.7
	35.0	1.5	1.3	1.8	1.5	2.1	1.7	2.2	1.7	2.3	1.7	2.5	1.7	2.6	1.7
37.0	1.5	1.3	1.8	1.5	2.1	1.7	2.2	1.7	2.3	1.7	2.4	1.7	2.5	1.7	
39.0	1.5	1.3	1.8	1.5	2.1	1.7	2.2	1.7	2.2	1.7	2.4	1.7	2.5	1.6	
25	10.0	1.9	1.6	2.3	1.8	2.6	2.0	2.8	2.1	3.0	2.0	3.3	2.1	3.7	2.1
	12.0	1.9	1.6	2.3	1.8	2.6	2.0	2.8	2.1	3.0	2.0	3.3	2.1	3.7	2.1
	14.0	1.9	1.6	2.3	1.8	2.6	2.0	2.8	2.1	3.0	2.0	3.3	2.1	3.7	2.1
	16.0	1.9	1.6	2.3	1.8	2.6	2.0	2.8	2.1	3.0	2.0	3.3	2.1	3.7	2.1
	18.0	1.9	1.6	2.3	1.8	2.6	2.0	2.8	2.1	3.0	2.0	3.3	2.1	3.7	2.1
	20.0	1.9	1.6	2.3	1.8	2.6	2.0	2.8	2.1	3.0	2.0	3.3	2.1	3.7	2.1
	21.0	1.9	1.6	2.3	1.8	2.6	2.0	2.8	2.1	3.0	2.0	3.3	2.1	3.7	2.1
	23.0	1.9	1.6	2.3	1.8	2.6	2.0	2.8	2.1	3.0	2.0	3.3	2.1	3.7	2.1
	25.0	1.9	1.6	2.3	1.8	2.6	2.0	2.8	2.1	3.0	2.0	3.3	2.1	3.6	2.1
	27.0	1.9	1.6	2.3	1.8	2.6	2.0	2.8	2.1	3.0	2.0	3.3	2.1	3.5	2.1
	29.0	1.9	1.6	2.3	1.8	2.6	2.0	2.8	2.1	3.0	2.0	3.3	2.1	3.5	2.1
	31.0	1.9	1.6	2.3	1.8	2.6	2.0	2.8	2.1	3.0	2.0	3.2	2.1	3.4	2.1
	33.0	1.9	1.6	2.3	1.8	2.6	2.0	2.8	2.1	3.0	2.0	3.2	2.1	3.4	2.0
	35.0	1.9	1.6	2.3	1.8	2.6	2.0	2.8	2.1	2.9	2.1	3.1	2.1	3.3	2.0
37.0	1.9	1.6	2.3	1.8	2.6	2.0	2.8	2.1	2.9	2.0	3.1	2.0	3.2	2.0	
39.0	1.9	1.6	2.3	1.8	2.6	2.0	2.7	2.1	2.8	2.0	3.0	2.0	3.2	2.0	
32	10.0	2.5	2.1	2.9	2.3	3.4	2.5	3.6	2.5	3.8	2.6	4.3	2.6	4.7	2.6
	12.0	2.5	2.1	2.9	2.3	3.4	2.5	3.6	2.5	3.8	2.6	4.3	2.6	4.7	2.6
	14.0	2.5	2.1	2.9	2.3	3.4	2.5	3.6	2.5	3.8	2.6	4.3	2.6	4.7	2.6
	16.0	2.5	2.1	2.9	2.3	3.4	2.5	3.6	2.5	3.8	2.6	4.3	2.6	4.7	2.6
	18.0	2.5	2.1	2.9	2.3	3.4	2.5	3.6	2.5	3.8	2.6	4.3	2.6	4.7	2.6
	20.0	2.5	2.1	2.9	2.3	3.4	2.5	3.6	2.5	3.8	2.6	4.3	2.6	4.7	2.6
	21.0	2.5	2.1	2.9	2.3	3.4	2.5	3.6	2.5	3.8	2.6	4.3	2.6	4.7	2.6
	23.0	2.5	2.1	2.9	2.3	3.4	2.5	3.6	2.5	3.8	2.6	4.3	2.6	4.7	2.6
	25.0	2.5	2.1	2.9	2.3	3.4	2.5	3.6	2.5	3.8	2.6	4.3	2.6	4.6	2.6
	27.0	2.5	2.1	2.9	2.3	3.4	2.5	3.6	2.5	3.8	2.6	4.3	2.6	4.6	2.6
	29.0	2.5	2.1	2.9	2.3	3.4	2.5	3.6	2.5	3.8	2.6	4.2	2.6	4.5	2.6
	31.0	2.5	2.1	2.9	2.3	3.4	2.5	3.6	2.5	3.8	2.6	4.2	2.6	4.4	2.6
	33.0	2.5	2.1	2.9	2.3	3.4	2.5	3.6	2.5	3.8	2.6	4.1	2.5	4.3	2.5
	35.0	2.5	2.1	2.9	2.3	3.4	2.5	3.6	2.5	3.8	2.5	4.0	2.5	4.2	2.5
37.0	2.5	2.1	2.9	2.3	3.4	2.5	3.6	2.5	3.7	2.5	3.9	2.5	4.2	2.5	
39.0	2.5	2.1	2.9	2.3	3.4	2.5	3.5	2.5	3.6	2.5	3.9	2.5	4.1	2.4	
40	10.0	3.1	2.5	3.7	2.8	4.2	3.1	4.5	3.1	4.8	3.2	5.3	3.3	5.9	3.3
	12.0	3.1	2.5	3.7	2.8	4.2	3.1	4.5	3.1	4.8	3.2	5.3	3.3	5.9	3.3
	14.0	3.1	2.5	3.7	2.8	4.2	3.1	4.5	3.1	4.8	3.2	5.3	3.3	5.9	3.3
	16.0	3.1	2.5	3.7	2.8	4.2	3.1	4.5	3.1	4.8	3.2	5.3	3.3	5.9	3.3
	18.0	3.1	2.5	3.7	2.8	4.2	3.1	4.5	3.1	4.8	3.2	5.3	3.3	5.9	3.3
	20.0	3.1	2.5	3.7	2.8	4.2	3.1	4.5	3.1	4.8	3.2	5.3	3.3	5.9	3.3
	21.0	3.1	2.5	3.7	2.8	4.2	3.1	4.5	3.1	4.8	3.2	5.3	3.3	5.9	3.3
	23.0	3.1	2.5	3.7	2.8	4.2	3.1	4.5	3.1	4.8	3.2	5.3	3.3	5.9	3.3
	25.0	3.1	2.5	3.7	2.8	4.2	3.1	4.5	3.1	4.8	3.2	5.3	3.3	5.8	3.2
	27.0	3.1	2.5	3.7	2.8	4.2	3.1	4.5	3.1	4.8	3.2	5.3	3.3	5.7	3.2
	29.0	3.1	2.5	3.7	2.8	4.2	3.1	4.5	3.1	4.8	3.2	5.3	3.2	5.6	3.2
	31.0	3.1	2.5	3.7	2.8	4.2	3.1	4.5	3.1	4.8	3.2	5.2	3.2	5.5	3.1
	33.0	3.1	2.5	3.7	2.8	4.2	3.1	4.5	3.1	4.8	3.2	5.1	3.2	5.4	3.1
	35.0	3.1	2.5	3.7	2.8	4.2	3.1	4.5	3.1	4.7	3.2	5.0	3.2	5.3	3.1
37.0	3.1	2.5	3.7	2.8	4.2	3.1	4.5	3.1	4.6	3.1	4.9	3.1	5.2	3.0	
39.0	3.1	2.5	3.7	2.8	4.2	3.1	4.4	3.1	4.5	3.1	4.8	3.1	5.1	3.0	

		Cooling capacity													
Unit Size	Outdoor air temp. °CDB	Indoor air temp.													
		14.0°CWB		16.0°CWB		18.0°CWB		19.0°CWB		20.0°CWB		22.0°CWB		24.0°CWB	
		20°CDB		23°CDB		26°CDB		27°CDB		28°CDB		30°CDB		32°CDB	
		TC	SHC	TC	SHC	TC	SHC	TC	SHC	TC	SHC	TC	SHC	TC	SHC
50	10.0	3.9	3.0	4.6	3.5	5.3	3.8	5.6	3.9	5.9	4.0	6.6	4.1	7.3	4.1
	12.0	3.9	3.0	4.6	3.5	5.3	3.8	5.6	3.9	5.9	4.0	6.6	4.1	7.3	4.1
	14.0	3.9	3.0	4.6	3.5	5.3	3.8	5.6	3.9	5.9	4.0	6.6	4.1	7.3	4.1
	16.0	3.9	3.0	4.6	3.5	5.3	3.8	5.6	3.9	5.9	4.0	6.6	4.1	7.3	4.1
	18.0	3.9	3.0	4.6	3.5	5.3	3.8	5.6	3.9	5.9	4.0	6.6	4.1	7.3	4.1
	20.0	3.9	3.0	4.6	3.5	5.3	3.8	5.6	3.9	5.9	4.0	6.6	4.1	7.3	4.1
	21.0	3.9	3.0	4.6	3.5	5.3	3.8	5.6	3.9	5.9	4.0	6.6	4.1	7.3	4.1
	23.0	3.9	3.0	4.6	3.5	5.3	3.8	5.6	3.9	5.9	4.0	6.6	4.1	7.3	4.1
	25.0	3.9	3.0	4.6	3.5	5.3	3.8	5.6	3.9	5.9	4.0	6.6	4.1	7.2	4.0
	27.0	3.9	3.0	4.6	3.5	5.3	3.8	5.6	3.9	5.9	4.0	6.6	4.1	7.1	4.0
	29.0	3.9	3.0	4.6	3.5	5.3	3.8	5.6	3.9	5.9	4.0	6.6	4.0	7.0	4.0
	31.0	3.9	3.0	4.6	3.5	5.3	3.8	5.6	3.9	5.9	4.0	6.6	3.9	6.8	4.0
	33.0	3.9	3.0	4.6	3.5	5.3	3.8	5.6	3.9	5.9	4.0	6.3	3.9	6.7	3.9
	35.0	3.9	3.0	4.6	3.5	5.3	3.8	5.6	3.9	5.9	3.9	6.2	3.9	6.6	3.8
37.0	3.9	3.0	4.6	3.5	5.3	3.8	5.6	3.9	5.8	3.9	6.1	3.9	6.5	3.8	
39.0	3.9	3.0	4.6	3.5	5.3	3.8	5.5	3.8	5.7	3.8	6.0	3.9	6.4	3.8	
63	10.0	4.9	3.8	5.8	4.3	6.7	4.8	7.1	4.9	7.5	5.0	8.4	5.1	9.3	5.0
	12.0	4.9	3.8	5.8	4.3	6.7	4.8	7.1	4.9	7.5	5.0	8.4	5.1	9.3	5.0
	14.0	4.9	3.8	5.8	4.3	6.7	4.8	7.1	4.9	7.5	5.0	8.4	5.1	9.3	5.0
	16.0	4.9	3.8	5.8	4.3	6.7	4.8	7.1	4.9	7.5	5.0	8.4	5.1	9.3	5.0
	18.0	4.9	3.8	5.8	4.3	6.7	4.8	7.1	4.9	7.5	5.0	8.4	5.1	9.3	5.0
	20.0	4.9	3.8	5.8	4.3	6.7	4.8	7.1	4.9	7.5	5.0	8.4	5.1	9.3	5.0
	21.0	4.9	3.8	5.8	4.3	6.7	4.8	7.1	4.9	7.5	5.0	8.4	5.1	9.3	5.0
	23.0	4.9	3.8	5.8	4.3	6.7	4.8	7.1	4.9	7.5	5.0	8.4	5.1	9.3	5.0
	25.0	4.9	3.8	5.8	4.3	6.7	4.8	7.1	4.9	7.5	5.0	8.4	5.1	9.1	4.9
	27.0	4.9	3.8	5.8	4.3	6.7	4.8	7.1	4.9	7.5	5.0	8.4	5.1	9.0	4.8
	29.0	4.9	3.8	5.8	4.3	6.7	4.8	7.1	4.9	7.5	5.0	8.3	5.0	8.8	4.9
	31.0	4.9	3.8	5.8	4.3	6.7	4.8	7.1	4.9	7.5	5.0	8.2	4.9	8.7	4.8
	33.0	4.9	3.8	5.8	4.3	6.7	4.8	7.1	4.9	7.5	5.0	8.0	4.9	8.5	4.7
	35.0	4.9	3.8	5.8	4.3	6.7	4.8	7.1	4.9	7.4	4.9	7.9	4.8	8.4	4.6
37.0	4.9	3.8	5.8	4.3	6.7	4.8	7.1	4.9	7.3	4.8	7.8	4.7	8.2	4.5	
39.0	4.9	3.8	5.8	4.3	6.7	4.8	6.9	4.8	7.2	4.8	7.6	4.7	8.1	4.4	

TC : Total capacity ; kW  
 SHC : Sensible heat capacity ; kW



Refer to Outdoor Unit Capacity Tables (in case of Inverter (5, 8, 10HP) : on page 380~, in case of PLUS (16~30HP) : on page 480~) for the actual performance data of each indoor and outdoor unit combination.



## 6.2 Heating Capacity

FXL – L / FXN – L

Heating Capacity

Unit Size	Outdoor air temp.		Indoor air temp. °CDB					
			16.0	18.0	20.0	21.0	22.0	24.0
	°CDB	°CWB	kW	kW	kW	kW	kW	kW
20	-13.7	-15.0	1.7	1.7	1.7	1.7	1.7	1.6
	-11.8	-13.0	1.8	1.8	1.8	1.8	1.8	1.7
	-9.8	-11.0	1.9	1.9	1.9	1.8	1.8	1.8
	-9.5	-10.0	2.0	1.9	1.9	1.9	1.9	1.9
	-8.5	-9.1	2.0	2.0	2.0	1.9	1.9	1.9
	-7.0	-7.6	2.1	2.0	2.0	2.0	2.0	2.0
	-5.0	-5.6	2.2	2.1	2.1	2.1	2.1	2.0
	-3.0	-3.7	2.2	2.2	2.2	2.2	2.2	2.1
	0.0	-0.7	2.4	2.3	2.3	2.3	2.3	2.1
	3.0	2.2	2.5	2.5	2.4	2.4	2.3	2.1
	5.0	4.1	2.6	2.6	2.5	2.4	2.3	2.1
	7.0	6.0	2.7	2.7	2.5	2.4	2.3	2.1
	9.0	7.9	2.8	2.7	2.5	2.4	2.3	2.1
	11.0	9.8	2.9	2.7	2.5	2.4	2.3	2.1
13.0	11.8	2.9	2.7	2.5	2.4	2.3	2.1	
15.0	13.7	2.9	2.7	2.5	2.4	2.3	2.1	
25	-13.7	-15.0	2.2	2.2	2.2	2.1	2.1	2.1
	-11.8	-13.0	2.3	2.3	2.3	2.3	2.2	2.2
	-9.8	-11.0	2.4	2.4	2.4	2.4	2.4	2.3
	-9.5	-10.0	2.5	2.5	2.4	2.4	2.4	2.4
	-8.5	-9.1	2.6	2.5	2.5	2.5	2.5	2.4
	-7.0	-7.6	2.7	2.6	2.6	2.6	2.5	2.5
	-5.0	-5.6	2.8	2.7	2.7	2.7	2.7	2.6
	-3.0	-3.7	2.9	2.8	2.8	2.8	2.8	2.7
	0.0	-0.7	3.0	3.0	3.0	2.9	2.9	2.7
	3.0	2.2	3.2	3.2	3.1	3.1	2.9	2.7
	5.0	4.1	3.3	3.3	3.2	3.1	2.9	2.7
	7.0	6.0	3.4	3.4	3.2	3.1	2.9	2.7
	9.0	7.9	3.5	3.5	3.2	3.1	2.9	2.7
	11.0	9.8	3.7	3.5	3.2	3.1	2.9	2.7
13.0	11.8	3.7	3.5	3.2	3.1	2.9	2.7	
15.0	13.7	3.7	3.5	3.2	3.1	2.9	2.7	
32	-13.7	-15.0	2.8	2.7	2.7	2.7	2.7	2.6
	-11.8	-13.0	2.9	2.9	2.8	2.8	2.8	2.8
	-9.8	-11.0	3.1	3.0	3.0	3.0	2.9	2.9
	-9.5	-10.0	3.1	3.1	3.1	3.0	3.0	3.0
	-8.5	-9.1	3.2	3.2	3.1	3.1	3.1	3.0
	-7.0	-7.6	3.3	3.3	3.2	3.2	3.2	3.1
	-5.0	-5.6	3.5	3.4	3.4	3.3	3.3	3.3
	-3.0	-3.7	3.6	3.5	3.5	3.5	3.5	3.4
	0.0	-0.7	3.8	3.8	3.7	3.7	3.7	3.4
	3.0	2.2	4.0	4.0	3.9	3.8	3.7	3.4
	5.0	4.1	4.2	4.1	4.0	3.8	3.7	3.4
	7.0	6.0	4.3	4.2	4.0	3.8	3.7	3.4
	9.0	7.9	4.4	4.3	4.0	3.8	3.7	3.4
	11.0	9.8	4.6	4.3	4.0	3.8	3.7	3.4
13.0	11.8	4.6	4.3	4.0	3.8	3.7	3.4	
15.0	13.7	4.6	4.3	4.0	3.8	3.7	3.4	
40	-13.7	-15.0	3.5	3.4	3.4	3.3	3.3	3.3
	-11.8	-13.0	3.7	3.6	3.6	3.5	3.5	3.5
	-9.8	-11.0	3.8	3.8	3.7	3.7	3.7	3.6
	-9.5	-10.0	3.9	3.9	3.8	3.8	3.8	3.7
	-8.5	-9.1	4.0	4.0	3.9	3.9	3.8	3.8
	-7.0	-7.6	4.1	4.1	4.0	4.0	4.0	3.9
	-5.0	-5.6	4.3	4.3	4.2	4.2	4.1	4.1
	-3.0	-3.7	4.5	4.4	4.4	4.3	4.3	4.2
	0.0	-0.7	4.8	4.7	4.6	4.6	4.6	4.2
	3.0	2.2	5.0	5.0	4.9	4.8	4.6	4.2
	5.0	4.1	5.2	5.1	5.0	4.8	4.6	4.2
	7.0	6.0	5.4	5.3	5.0	4.8	4.6	4.2
	9.0	7.9	5.5	5.4	5.0	4.8	4.6	4.2
	11.0	9.8	5.7	5.4	5.0	4.8	4.6	4.2
13.0	11.8	5.8	5.4	5.0	4.8	4.6	4.2	
15.0	13.7	5.8	5.4	5.0	4.8	4.6	4.2	

## Heating Capacity

Unit Size	Outdoor air temp.		Indoor air temp. °CDB					
			16.0	18.0	20.0	21.0	22.0	24.0
	°CDB	°CWB	kW	kW	kW	kW	kW	kW
50	-13.7	-15.0	4.4	4.3	4.3	4.2	4.2	4.1
	-11.8	-13.0	4.6	4.5	4.5	4.4	4.4	4.4
	-9.8	-11.0	4.8	4.8	4.7	4.7	4.6	4.6
	-9.5	-10.0	4.9	4.9	4.8	4.8	4.7	4.7
	-8.5	-9.1	5.0	5.0	4.9	4.9	4.8	4.8
	-7.0	-7.6	5.2	5.1	5.1	5.0	5.0	4.9
	-5.0	-5.6	5.4	5.4	5.3	5.3	5.2	5.2
	-3.0	-3.7	5.7	5.6	5.5	5.5	5.4	5.3
	0.0	-0.7	6.0	5.9	5.8	5.8	5.8	5.3
	3.0	2.2	6.3	6.2	6.2	6.1	5.8	5.3
	5.0	4.1	6.5	6.5	6.3	6.1	5.8	5.3
	7.0	6.0	6.8	6.7	6.3	6.1	5.8	5.3
	9.0	7.9	7.0	6.8	6.3	6.1	5.8	5.3
	11.0	9.8	7.2	6.8	6.3	6.1	5.8	5.3
13.0	11.8	7.3	6.8	6.3	6.1	5.8	5.3	
15.0	13.7	7.3	6.8	6.3	6.1	5.8	5.3	
63	-13.7	-15.0	5.6	5.5	5.4	5.4	5.3	5.3
	-11.8	-13.0	5.8	5.8	5.7	5.6	5.6	5.5
	-9.8	-11.0	6.1	6.0	6.0	5.9	5.9	5.8
	-9.5	-10.0	6.3	6.2	6.1	6.1	6.0	5.9
	-8.5	-9.1	6.4	6.3	6.2	6.2	6.1	6.1
	-7.0	-7.6	6.6	6.5	6.5	6.4	6.4	6.3
	-5.0	-5.6	6.9	6.8	6.7	6.7	6.6	6.6
	-3.0	-3.7	7.2	7.1	7.0	7.0	6.9	6.8
	0.0	-0.7	7.6	7.5	7.4	7.4	7.3	6.8
	3.0	2.2	8.1	7.9	7.8	7.7	7.4	6.8
	5.0	4.1	8.3	8.2	8.0	7.7	7.4	6.8
	7.0	6.0	8.6	8.5	8.0	7.7	7.4	6.8
	9.0	7.9	8.9	8.6	8.0	7.7	7.4	6.8
	11.0	9.8	9.1	8.6	8.0	7.7	7.4	6.8
13.0	11.8	9.2	8.6	8.0	7.7	7.4	6.8	
15.0	13.7	9.2	8.6	8.0	7.7	7.4	6.8	

TC : Total capacity ; kW

SHC : Sensible heat capacity ; kW



Refer to Outdoor Unit Capacity Tables (in case of Inverter (5, 8, 10HP) : on page 380~, in case of PLUS (16~30HP) : on page 480~) for the actual performance data of each indoor and outdoor unit combination.

## 7. Electric Characteristics

Model	Units			Power supply		IFM		Input(W)	
	Hz	Volts	Voltage range	MCA	MFA	KW	FLA	Cooling	Heating
FXL • FXN20LVE	50	220-240	MAX. 264 Min. 198	0.3	15	0.015	0.2	49	49
FXL • FXN25LVE				0.3	15	0.015	0.2	49	49
FXL • FXN32LVE				0.6	15	0.025	0.5	90	90
FXL • FXN40LVE				0.6	15	0.025	0.5	90	90
FXL • FXN50LVE				0.6	15	0.035	0.5	110	110
FXL • FXN63LVE				0.6	15	0.035	0.5	110	110
FXL • FXN20LVE	60	220	MAX. 242 Min. 198	0.3	15	0.015	0.2	47	47
FXL • FXN25LVE				0.3	15	0.015	0.2	47	47
FXL • FXN32LVE				0.5	15	0.025	0.4	79	79
FXL • FXN40LVE				0.5	15	0.025	0.4	84	84
FXL • FXN50LVE				0.6	15	0.035	0.5	105	105
FXL • FXN63LVE				0.6	15	0.035	0.5	108	108

### Symbols :

MCA : Min. Circuit Amps (A)  
 MFA : Max. Fuse Amps (See note 5)  
 KW : Fan Motor Rated Output(KW)  
 FLA : Full Load Amps(A)  
 IFM : Indoor Fan Motor

### Note :

- Voltage range  
Units are suitable for use on electrical systems where voltage supplied to unit terminals is not below or above listed range limits.
- Maximum allowable voltage unbalance between phases is 2%.
- MCA/MFA  
 $MCA = 1.25 \times FLA$   
 $MFA \leq 4 \times FLA$   
 (Next lower standard fuse rating, Min. 15A)
- Select wire size based on the MCA.
- Instead of fuse, use Circuit Breaker.

4D034579

# 8. Sound Levels

## Overall

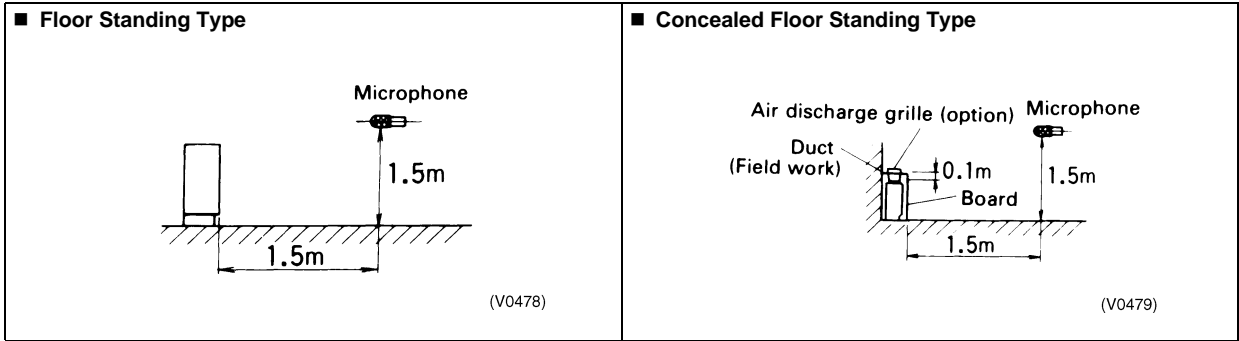

dBA

dBA

Model	220V 50 / 60Hz		240V 50Hz		Model	220V 50 / 60Hz		240V 50Hz	
	H	L	H	L		H	L	H	L
FXL20L FXL25L FXL32L	35	32	37	34	FXN20L FXN25L FXN32L	35	32	37	34
FXL40L	38	33	40	35	FXN40L	38	33	40	35
FXL50L	39	34	41	36	FXN50L	39	34	41	36
FXL63L	40	35	42	37	FXN63L	40	35	42	37

**Notes:**

1. The operating conditions are assumed to be standard (JIS conditions)
2. These operating values were obtained in a dead room (conversion values).  
Sound level will vary depending on a range of factors such as the construction (acoustic absorption coefficient) of the particular room in which the equipments installed.

Octave Band Level

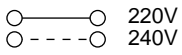

FXL20L-25LVE

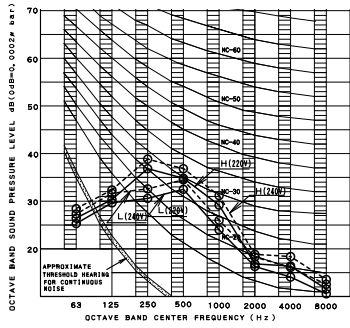

4D034528

FXL32LVE

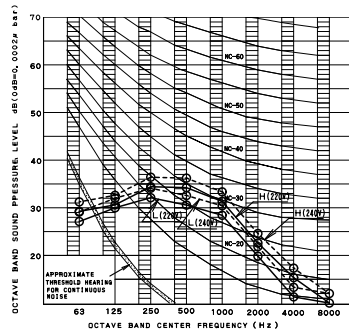

4D034564

FXL40LVE

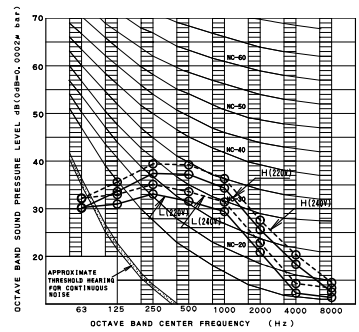

4D034565

FXL50LVE

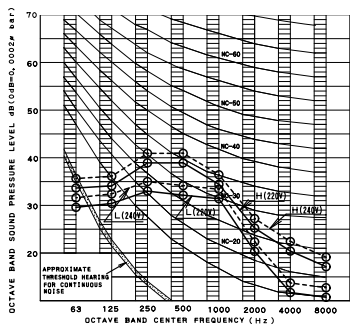

4D034566

FXL63LVE

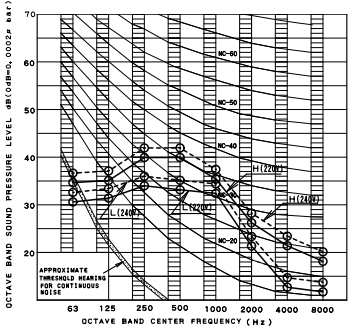

4D034567

FXN20L-25LVE

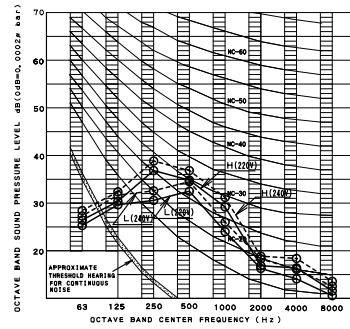

4D034534

FXN32LVE

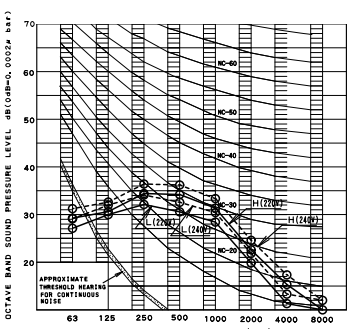

4D034535

FXN40LVE

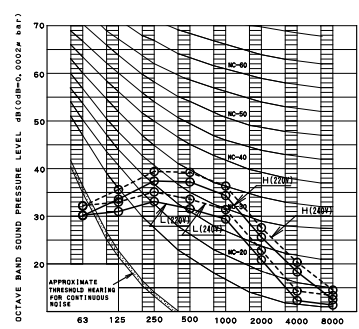

4D034536

FXN50LVE

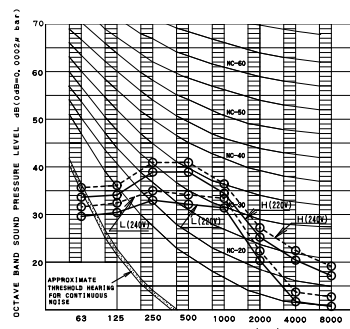

4D034537

FXN63LVE

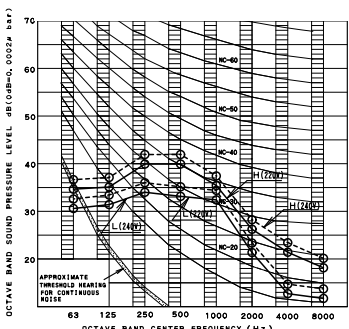

4D034538

# 9. Installation

## Installation Example

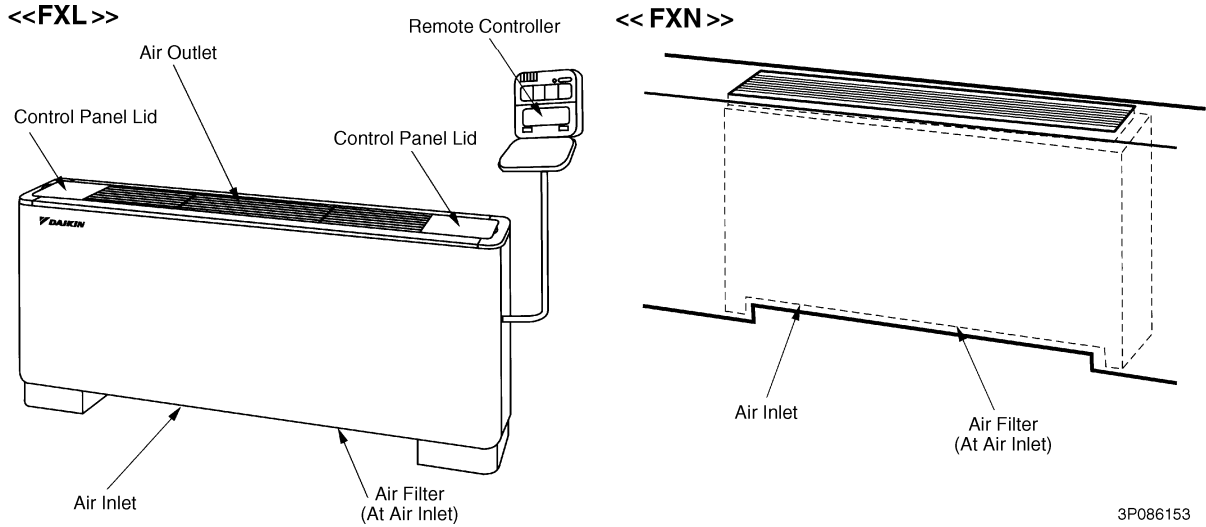

3P086153

## Service Space

- ① Select an installation site where the following conditions are satisfied and that meets with your customer's approval.
  - Where the floor is strong enough to bear the indoor unit weight.
  - Where the floor is not significantly inclined.
  - Where nothing blocks the air passage.
  - Where condensate can be properly drained.
  - Where sufficient clearance for installation and maintenance can be ensured.
  - Where there is no possibility of flammable gas leakage.
  - Where optimum air distribution can be ensured.
  - Where piping between indoor and outdoor units is possible within the allowable limit (Refer to the installation manual of the outdoor unit.)
  - Keep the indoor and outdoor units, power cable and transmission wiring, at least 1 m from TVs and radios, to prevent distorted pictures and static. (Depending on the type and source of the electrical waves, static may be heard even when more than 1 m away.)

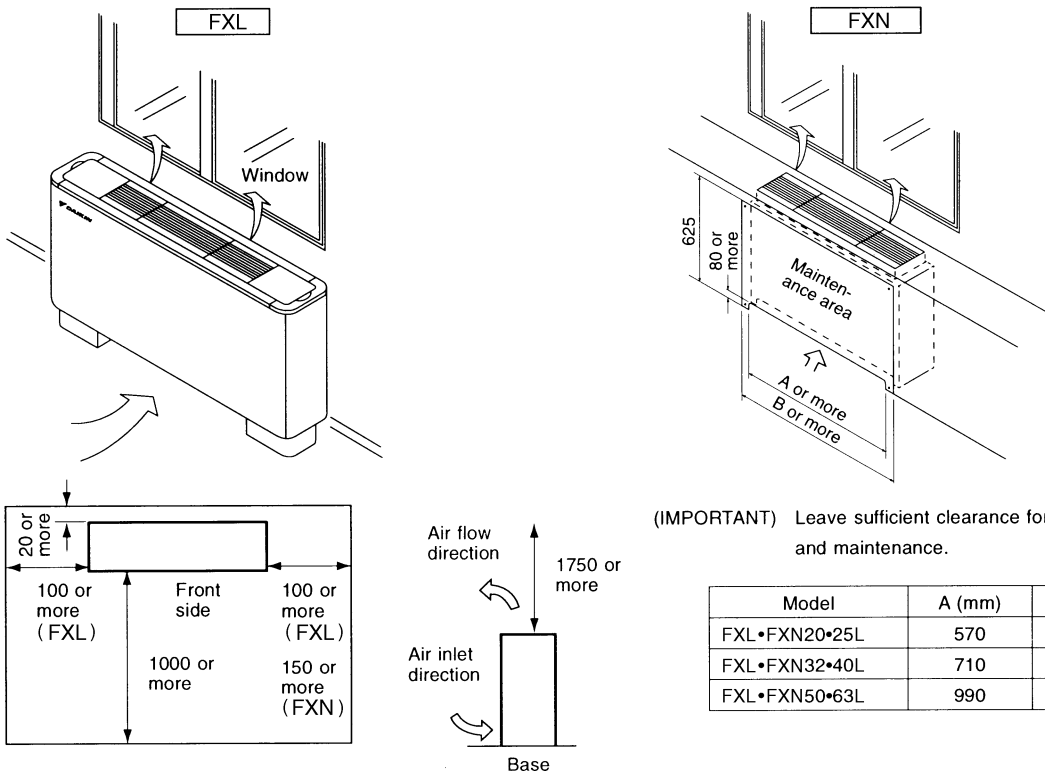

3PN86154-1-4

Center of Gravity

FXL

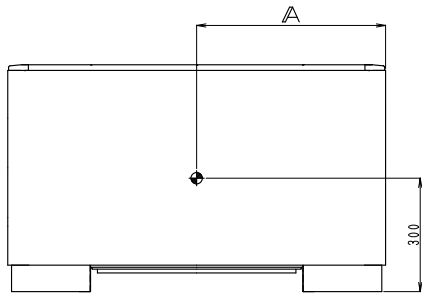

	A
FXL20•25LVE	500
FXL32•40LVE	570
FXL50•63LVE	710

4D034527

FXN

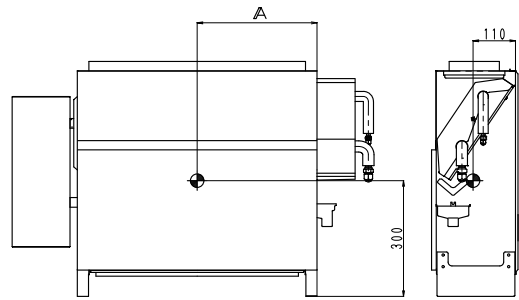

	A
FXN20•25LVE	395
FXN32•40LVE	465
FXN50•63LVE	505

4D034533

Bolt Pitch

① Positioning of holes for fastening to the wall

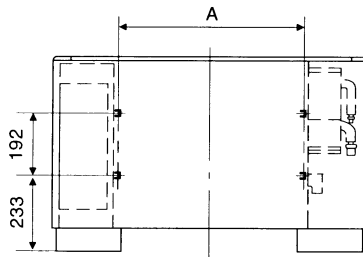

Model	A
FXL•FXN20•25L	590
FXL•FXN40•50L	730
FXL•FXN50•63L	1010

② How to open/close the front panel

- I) Open the lid of control panel (both left and right)
  - II) Remove screws (both left and right) that lock the knobs in position.
  - III) Push the knobs (both left and right) to the rear.
  - IV) Lift the front of the top plate.
  - V) Lower the front panel towards the front of the unit.
- To close, perform the procedure in opposite order. Pull towards the front until the knob snaps in place.

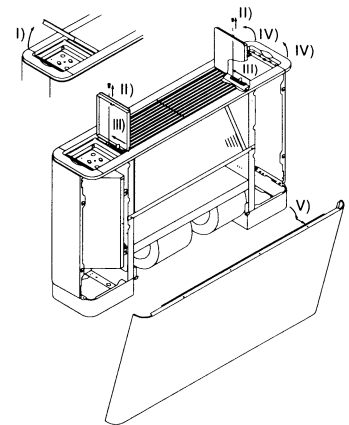

3PN86154-1-5

9

Drain Piping Work

« Rig the drain pipe as shown below and take measures against condensation. Improperly rigged piping could lead to leaks and eventually wet furniture and belongings. »

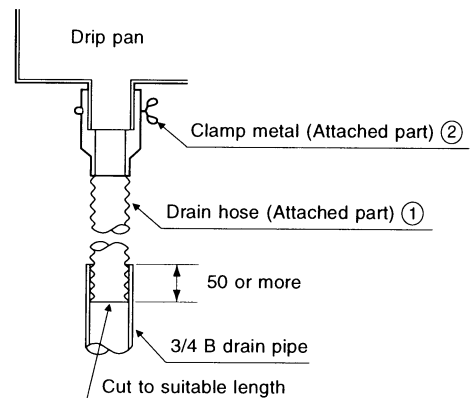

- ① Connect the drain hose ① using the attached hose and parts, as shown in the right drawing.
- ② After piping work is finished, check drainage flows smoothly.
- ③ Be sure to insulate all indoor pipes.



3PN86154-1-7

# 10. Accessories

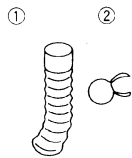
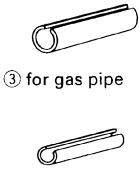
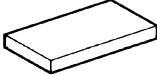
## Standard Accessories

Name	Drain hose	Insulation for fitting	Sealing pad	Clamp	Level adjustment screw	(Other)
Quantity	1 set	1 set	1 set	8	4	<ul style="list-style-type: none"> <li>• Operation manual</li> <li>• Installation manual</li> </ul>
Shape	 <p>Hose × 1 Clamp metal × 1</p>	 <p>③ for gas pipe ④ for liquid pipe</p>				

3PO86154-1-3

## Optional Accessories (For Unit)

No.	Item	Type	FXL20L FXN20L	FXL25L FXN25L	FXL32L FXN32L	FXL40L FXN40L	FXL50L FXN50L	FXL63L FXN63L
1	Long life replacement filter		KAFJ361K28		KAFJ361K45		KAFJ361K71	

## Optional Accessories (For Controls) Refer to P.640

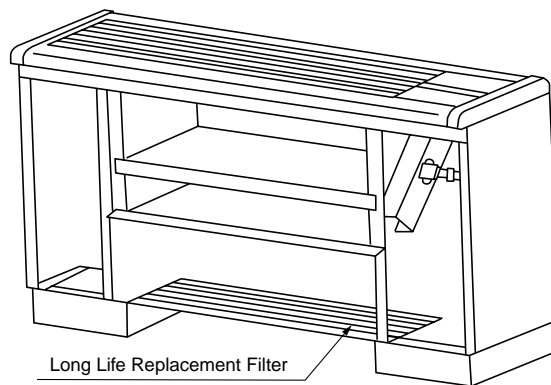

(V0683)