

---

 **SYSTEM Inverter Air Conditioners**

---

**MODELS****Ceiling-mounted duct type low static pressure unit****FXDQ20PVE****FXDQ25PVE****FXDQ32PVE**

English

Deutsch

Français

Español

Italiano

Ελληνικά

Nederlands

Portugues

Русский

Türkçe

中文  
(繁體)中文  
(简体)

Thank you for purchasing this Daikin air conditioner.

Carefully read this operation manual before using the air conditioner.

This operation manual is prepared for only the indoor unit. To understand the whole set fully, read this manual together with the operation manual for the outdoor unit.

The next items are described in the operation manual for the outdoor unit.

- Part names and functions of remote controller
- Operation procedure
- Troubleshooting

For the warranty card, receive it from your dealer and store it with this operation manual.

Vielen Dank für den Kauf einer Klimaanlage von Daikin.

Lesen Sie dieses Betriebshandbuch vor Inbetriebnahme der Klimaanlage sorgfältig durch.

In diesem Handbuch wird nur die Installation der Raumeinheit beschrieben. Um die Gesamtanlage zu verstehen, lesen sie dieses Handbuch zusammen mit dem Handbuch der Außeneinheit.

In der Bedienungsanleitung der Außeneinheit finden Sie Details zu den folgenden Punkten.

- Teilebezeichnungen und Funktionen der Fernbedienung
- Bedienung
- Fehlersuche

Verwahren Sie die Garantiekarte, die Sie von Ihrem Händler erhalten, zusammen mit dieser Bedienungsanleitung auf.

Nous vous remercions pour votre acquisition de ce système de climatisation Daikin.

Lisez attentivement ce manuel avant d'utiliser le climatiseur.

Ce mode d'emploi ne concerne que l'unité intérieure. Pour bien comprendre tout le système, lisez ce mode d'emploi et celui de l'unité extérieure.

Les points suivants sont décrits dans le mode d'emploi de l'unité extérieure.

- Nom des pièces et fonctions de la télécommande
- Procédure d'utilisation
- Dépannage

Faites-vous remettre le bon de garantie par votre revendeur et rangez-le avec le mode d'emploi.

Le agradecemos la compra de este acondicionador de aire Daikin.

Lea cuidadosamente el manual de funcionamiento antes de utilizar el acondicionador de aire.

Este manual de uso hace referencia únicamente a la unidad interior. Para obtener información de todo el conjunto, lea este manual junto con el manual de uso para la unidad exterior.

Los siguientes elementos se describen en el manual de uso de la unidad exterior.

- Nombres de componentes y funciones del control remoto
- Procedimiento de funcionamiento
- Solución de problemas

Solicite la tarjeta de garantía a su concesionario y guárdela con este manual de uso.

La ringraziamo di aver acquistato questo condizionatore d'aria Daikin.

Leggere attentamente questo manuale prima di utilizzare il condizionatore.

Questo manuale di istruzioni riguarda solo l'unità interna. Per imparare a usare l'intero sistema, leggere questo manuale insieme al manuale di istruzioni dell'unità esterna.

Le voci seguenti vengono trattate nel manuale di istruzioni dell'unità esterna.

- Nome delle parti e funzioni del telecomando
- Procedure operative
- Risoluzione dei problemi

Per quanto riguarda il certificato di garanzia, esso viene consegnato al cliente dal rivenditore e il cliente è invitato a conservarlo insieme al manuale di istruzioni.

Σας ευχαριστούμε που αγοράσατε αυτή την κλιματιστική συσκευή της Daikin.

Διαβάστε προσεκτικά αυτό το εγχειρίδιο χρήσης πριν χρησιμοποιήσετε την κλιματιστική συσκευή.

Το παρόν εγχειρίδιο λειτουργίας έχει ετοιμαστεί μόνο για την εσωτερική μονάδα. Για την πλήρη κατανόηση όλου του συνόλου, διαβάστε το παρόν εγχειρίδιο μαζί με το εγχειρίδιο λειτουργίας της εξωτερικής μονάδας.

Τα επόμενα αντικείμενα περιγράφονται στο εγχειρίδιο λειτουργίας της εξωτερικής μονάδας.

- Όνομα ανταλλακτικών και λειτουργία του τηλεχειριστηρίου
- Διαδικασία λειτουργίας
- Αντιμετώπιση προβλημάτων

Για την κάρτα εγγύησης, παραλάβετε την από τον αντιπρόσωπο σας και κρατήστε την μαζί με το εγχειρίδιο λειτουργίας.

Wij danken u voor de aankoop van deze Daikin-airconditioner.

Lees deze bedrijfshandleiding aandachtig door voordat u de airconditioner gebruikt.

Deze bedieningshandleiding is alleen bedoeld voor de binnenunit. Lees deze handleiding en de bedieningshandleiding voor de buitenunit aandachtig door om de werking van het hele systeem te begrijpen.

In de bedieningshandleiding voor de buitenunit zijn de volgende items zijn beschreven.

- Onderdelenamen en functies van de afstandsbediening
- Bedieningsprocedure
- Storingen verhelpen

Bewaar de garantiekaart die u van uw leverancier ontvangt bij deze bedieningshandleiding.

Obrigado pela sua compra deste aparelho de ar condicionado Daikin.

Leia com atenção este manual de operação antes de proceder à utilização do aparelho de ar condicionado.

Este manual de utilização destina-se exclusivamente à unidade interior. Para entender exhaustivamente a totalidade do aparelho, leia este manual em conjunto com o manual de utilização da unidade exterior.

Os itens seguintes são descritos no manual de utilização da unidade exterior.

- Nomes de peças e funções do controlador remoto
- Procedimento de funcionamento
- Resolução de Problemas

Relativamente ao cartão de garantia, obtenha-o junto do representante e guarde-o com este manual de funcionamento.

Благодарим за покупку кондиционера Daikin.

До начала работы с кондиционером внимательно изучите данное руководство по эксплуатации.

Данное руководство по эксплуатации относится только к комнатному блоку. Для того чтобы полностью ознакомиться с комплектом, прочтите данное руководство вместе с руководством по эксплуатации наружного блока.

В руководстве по эксплуатации наружного блока приводится описание следующих пунктов.

- Наименования частей и функции удаленного контроллера
- Процедура эксплуатации
- Поиск и устранение неисправностей

Получите у Вашего дилера гарантийный талон и храните его вместе с данным руководством по эксплуатации.

Daikin klima satın aldığınız için teşekkür ederiz.

Klimanızı kullanmadan önce bu kullanma kılavuzunu dikkatlice okuyunuz.

Bu işletme elkitabı sadece iç ünite için hazırlanmıştır. Tüm seti tam anlamak için, bu elkitabını dış ünitenin işletme elkitabıyla birlikte okuyun.

Aşağıdaki öğeler, dış ünitenin işletme elkitabında açıklanmıştır.

- Parça adları ve uzaktan kumandanın işlevleri
- Çalışma prosedürü
- Arıza giderme

Garanti kartını satıcınızdan alın ve bu işletme elkitabıyla birlikte saklayın.

感謝您購買大金空調機。

為確保正確使用本空調機，請務必仔細閱讀本使用說明書。

本書為室內機專用的使用說明書，請參照室外機使用說明書一起閱讀。

以下項目在室外機使用說明書中記載。

- 遙控器各部分名稱及其功能
- 操作步驟
- 故障診斷

請將購買本機後銷售商給您的保修證與本使用說明書一起妥善保管好。

感谢您购买大金空调机。

为确保正确使用本空调机，请务必仔细阅读本使用说明书。

本书为室内机专用的使用说明书，请参照室外机使用说明书一起阅读。

以下项目在室外机使用说明书中记载。

- 遥控器各部分名称及其功能
- 操作步骤
- 故障诊断

请将购买本机后销售商给您的保修证与本使用说明书一起妥善保管好。

# Part name and functions

## In case of suction from bottom side

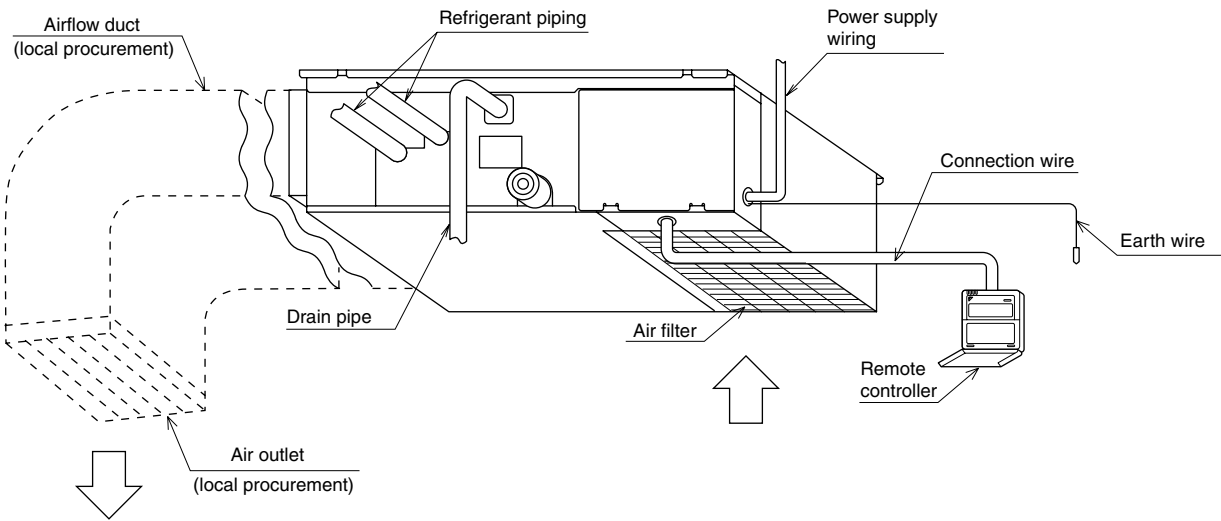

## In case of suction from back side

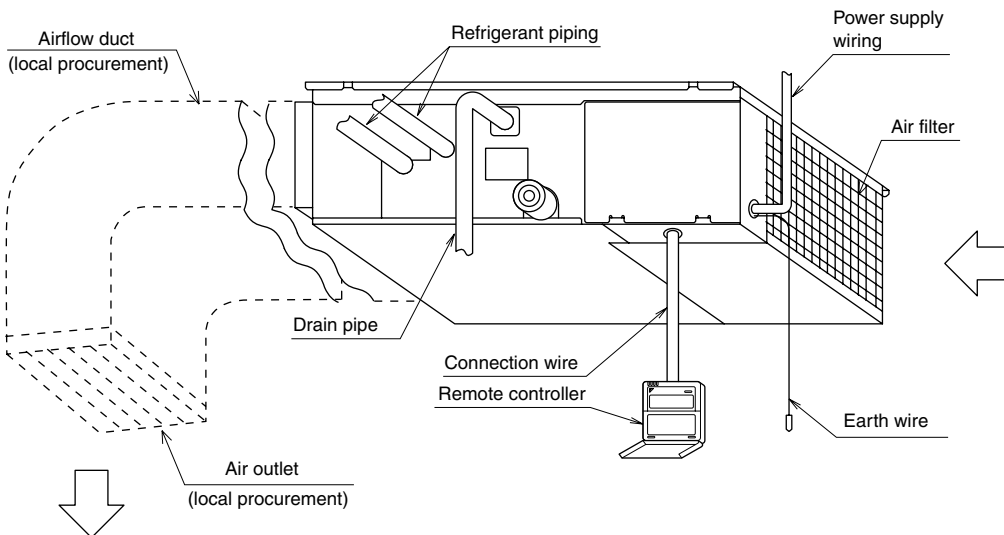

## Important information regarding the refrigerant used

This product contains fluorinated greenhouse gases covered by the Kyoto Protocol.

Refrigerant type: R410A

GWP<sup>(1)</sup> value: 1975

<sup>(1)</sup> GWP = global warming potential

Periodical inspections for refrigerant leaks may be required depending on European or local legislation. Please contact your local dealer for more information.

## Safety considerations

**Be sure to follow them.**

**<Before operation, read this operation manual carefully to operate it properly.>**

- This air conditioner comes under the term “appliances not accessible to the general public”.
- **Cautions indicated here are classified into the following two types.**  
**Each type of caution describes important contents relate to safety. Make sure to observe each caution.**

**⚠ WARNING** ..... These are the matters with possibilities leading to serious consequences such as death or serious injury due to erroneous handling.

**⚠ CAUTION** ..... These are the matters with possibilities leading to injury or material damage due to erroneous handling including probabilities leading to serious consequences in some cases.

**⚠ CAUTION**

- **Do not place objects in direct proximity of the outdoor unit and do not let leaves and other debris accumulate around the unit.**

Leaves are a hotbed for small animals which can enter the unit. Once in the unit, such animals can cause malfunctions, smoke or fire when making contact with electrical parts.

## Maintenance

**⚠ WARNING**

- **Only a qualified person is allowed to perform maintenance without daily maintenance.**
- **Before touching any of connection wirings, be sure to turn off all power supply switches.**
- **For installation of optional parts, only a qualified person is allowed to do so.**  
Be sure to use optional parts specified by our company. Installation in your own manner may result in water leakage, electric shock or fire.

**⚠ CAUTION**

- **Be sure to stop operation and turn the power switch off before cleaning the air conditioner.**  
Otherwise, an electric shock or injury may result.
- **Do not wash the air conditioner with water.**  
Doing so may result in an electric shock.
- **Consult with installation contractor for cleaning the inside of the air conditioner.**  
Wrong cleaning may make the plastics parts broken or cause failure of water leakage or electric shock.
- **Watch your steps at the time of air filter cleaning or inspection.**  
High-place work is required, to which utmost attention must be paid.  
If the scaffold is unstable, you may fall or topple down, thus causing injury.

(Maintenance and inspection)

- Clean the drain pan periodically. The drain pipes clogged with dust will cause water leakage.
- For cleaning, consult with your Daikin dealer. (Before each season when cooling or heating is required, clean the air conditioner.)
- If the area around the indoor unit is very dusty, use a dust-proof cover (local procurement).



(Cleaning the inside of the indoor unit)

- It is necessary to clean the inside of the indoor unit periodically.  
Since the cleaning requires special technologies, request a Daikin dealer to clean them.

**Daily maintenance:**

(Cleaning the air filter)

**Explanation**

- Removing the air filter except when cleaning the air conditioner may result in accidents.
- When the  mark is displayed on the remote controller, please clean the filter.
- When the operating time exceeds the designated time, this mark will be displayed.
- If using the air conditioner under very dusty environment, increase the frequency of air filter cleaning.
- When you want to change the setting time until the  mark is displayed, consult with your dealer. (The default factory setting is 2500 hours.)
- There are the following time, display pattern.  
1250, 2500, 5000, 10000

### 1. Remove the air filter.

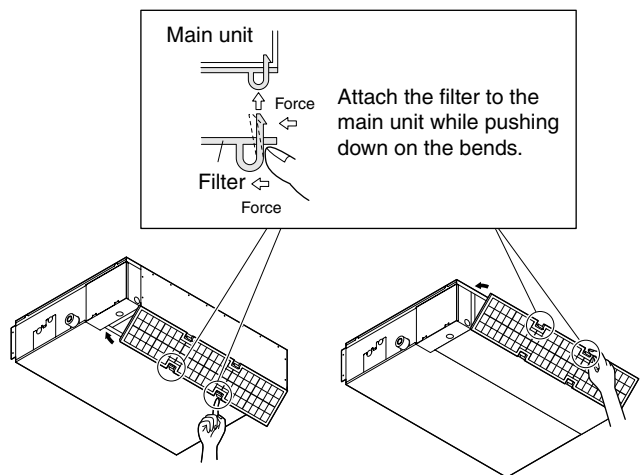

In case of bottom side

In case of back side

### 2. Clean it.

**⚠ CAUTION**

- Do not wash the air conditioner with hot water of more than 50°C. Doing so may result in discoloration or deformation.
- Never dry the filter by direct firing. Doing so may result in burning.
- For cleaning local procurements, consult with your dealer.

- (1) Use a vacuum cleaner (A) or wash the air filter (B) to remove dust and trash.

- (A) Remove dust and trash using a vacuum cleaner.



- (B) Wash it with water. When the air filter is very dirty, use a soft brush and neutral detergent.



Dewater and dry in the shade.



### 3. Attach the air filter.

### 4. Push the “filter sign reset” button on the remote controller.

The display “” vanishes.

(Cleaning the air outlet and exterior)

### ⚠ CAUTION

- Do not use gasoline, benzene, thinner, polishing powder or liquid insecticide.
- Do not use hot water of 50°C or higher, as doing so may result in discoloration or deformation.

- (1) Clean with dry soft cloth. (When it is difficult to remove stains, use water or neutral detergent.)

**If the following phenomenon occurs, contact your dealer.**

### ⚠ WARNING

- **When any abnormality is found (burnt odor), turn off the power switch.**  
Continued operation under such circumstances may result in a failure, electric shock or fire.
- **Contact your dealer.**

#### Phenomenon

- If a safety device such as a fuse, a breaker or an earth leakage breaker frequently actuates;  
**Take the following actions before contact.**  
Do not turn on the main power switch.
- If the ON/OFF switch does not properly work;  
**Take the following actions before contact.**  
Turn off the main power switch.

#### Phenomenon

- Water leaks out from the air conditioner.  
**Take the following actions before contact.**  
Stop the operation.

#### Phenomenon

- The “OPERATION lamp”, “INSPECTION display” or “UNIT No.” is winking and lit, and “MALFUNCTION CODE” is displayed.

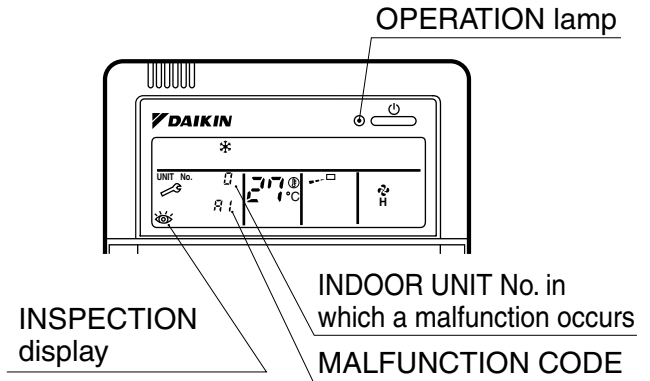

#### Take the following actions before contact.

Inform the dealer of the details being displayed on the remote controller.

## Product type and running noise

Model		Model No.		
		FXDQ20PVE	FXDQ25PVE	FXDQ32PVE
Type	Function	Heat pump type		
	Combination system	Separate type		
	Condenser cooling method	Air cooling type		
	Air blowing method	Direct air-blowing type		
	Rated cooling capacity (W)	2200	2800	3600
	Rated heating capacity (W)	2500	3200	4000
Operating sound dB (A) (conversion values under noise-less room)		33	33	33

#### Explanation

- The actual value during operation is higher than the indicated value under the influence of environmental noise and echo.
- The above data is subject to change by means of technological innovation.
- The operating sound is based on the rear side suction inlet, and the external static pressure 10Pa.  
Operating sound for under suction inlet:  
[operating sound for rear side suction inlet] + 5dB.  
However, when installation to which the external static pressure becomes low is carried out 5dB or more may go up.

## After-sales service and maintenance

### After-sales service:

#### — **WARNING** —

- **Ask your dealer for repair.**  
Incomplete repair may result in water leakage, electric shock and fire.
- **Ask your dealer to move and reinstall the air conditioner.**  
Incomplete installation may result in water leakage, electric shock and fire.
- **The refrigerant used in the air conditioner is safe.**  
**Although the refrigerant does not usually leak, if the refrigerant leaks out into a room and comes in contact with the combustible air in the equipment such as fan heater, stove, oil (gas) cooker, etc., it will cause toxic gas to be generated.**  
When a refrigerant leakage failure has been repaired, confirm a service person that the leakage point has been corrected surely before restarting operation.

- 
- **When asking your dealer to repair, inform related staff of the details as follows:**
    - Product No. of air conditioner:  
Refer to the warranty card.
    - Shipping date and installation date:  
Refer to the warranty card.
    - Malfunction:  
Inform the staff of the defective details.  
(Malfunction code being displayed on the remote controller.)
    - Name, address, telephone number
  - **Repair where the warranty term is expired**  
Contact your dealer. If necessary to repair, pay service is available.
  - **Minimum storage period of important parts**  
Even after a certain type of air conditioner is discontinued, we at Daikin have the related important parts in stock for 9 years at least. The important parts indicate parts essential to operate the air conditioner.
  - **Maintenance and inspection**  
Since dust collects after using the unit for several years, the performance will be deteriorated to some extent.

It is recommended to request the technical staff to perform maintenance (pay service). For further details, consult with your dealer.

- **Where to call**  
For after-sales service, etc., consult with your dealer.
- **When disposing the air conditioner, removing/installing and maintaining it, collect the refrigerant.**

### Warranty period:

- This product includes a warranty card.  
The warranty card is given to a customer after dealer staff fills out necessary items in the card. The customer should check the entered items and store it carefully.  
  
Warranty period: Within one year after installation.  
For further details, refer to the warranty card.
- If it is necessary to repair the air conditioner within the warranty period, contact your dealer and show your warranty card. If the warranty card is not shown, pay-service repair may be performed even though the warranty period is not expired.

**DAIKIN INDUSTRIES, LTD.**

Head office:  
Umeda Center Bldg., 2-4-12, Nakazaki-Nishi,  
Kita-ku, Osaka, 530-8323 Japan

Tokyo office:  
JR Shinagawa East Bldg., 2-18-1, Konan,  
Minato-ku, Tokyo, 108-0075 Japan

**大金工業株式会社**

總公司  
日本大阪府大阪市北區中崎西二丁目4番12號  
梅田中心大廈 郵政編碼 530-8323

東京分公司  
日本東京都港區港南二丁目18番1號  
JR品川東大廈 郵政編碼108-0075

**DAIKIN EUROPE NV**

Zandvoordestraat 300, B-8400 Oostende, Belgium

**大金工業株式会社**

总公司  
日本大阪府大阪市北區中崎西二丁目4番12号  
梅田中心大廈 邮政编码 530-8323

东京分公司  
日本东京都港区港南二丁目18番1号  
JR品川东大厦 邮政编码108-0075