



REMOVAL PROCEDURE



S E R V I C E M A N U A L

2.5/3.5/5.0 kW Class

-  Indoor Unit
-  Inverter
-  Wall Mounted Type



Service Manual Removal Procedure

Indoor Unit

●Heat Pump

FTXZ25NV1B

FTXZ35NV1B

FTXZ50NV1B

Table of Contents

1. Front Panel.....	2
2. Streamer Unit / Dust Box	3
3. Filters	4
4. Front Grilles / Horizontal Blades	6
5. Electrical Box / PCBs	10
6. Filter Cleaning Unit.....	19
7. Humidifying Duct.....	23
8. Swing Motors	24
9. Indoor Heat Exchanger	28
10. Fan Rotor / Fan Motor.....	31



Note: ♦ The illustrations may be slightly different depending on the model.

1. Front Panel



Warning

◆ Be sure to wait for 10 minutes or more after turning off all power supplies before disassembling work.

Step	Procedure	Points
1. Appearance features	<p style="text-align: right;">(R19803)</p>	
2. Remove the front panel.	<p>1 Open the front panel.</p> <p style="text-align: right;">(R19804)</p> <p>2 Slide the left rotary shaft to the outside and release it.</p> <p style="text-align: right;">(R19805)</p> <p>3 Release the right rotary shaft in the same way.</p> <p style="text-align: right;">(R19806)</p> <p>4 Remove the front panel.</p> <p style="text-align: right;">(R19807)</p>	

2. Streamer Unit / Dust Box



Warning

◆ Be sure to wait for 10 minutes or more after turning off all power supplies before disassembling work.

Step	Procedure	Points
1. Remove the streamer unit.	<p style="text-align: right;">(R19808)</p>	<p>■ The streamer unit can be removed without removing the front panel.</p>
2. Remove the dust box.	<p style="text-align: right;">(R19809)</p> <p style="text-align: right;">(R19810)</p> <p style="text-align: right;">(R19811)</p>	

3. Filters



Warning

◆ Be sure to wait for 10 minutes or more after turning off all power supplies before disassembling work.

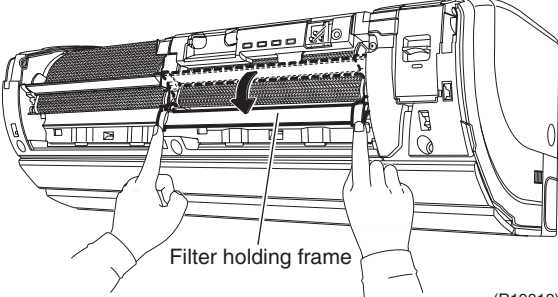
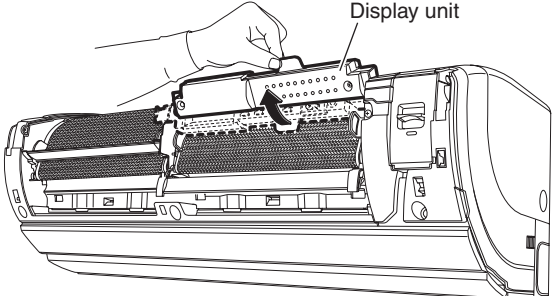
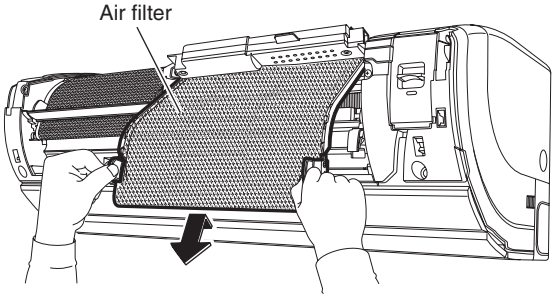
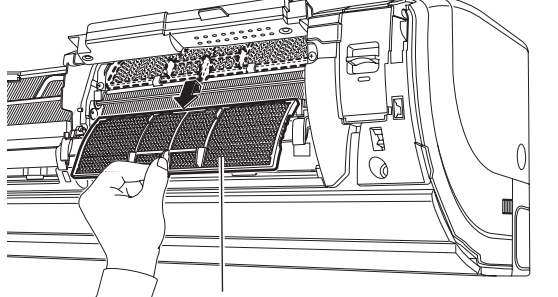
Step	Procedure	Points
<p>1. Remove the air filter.</p> <p>1 Pull down the filter holding frame.</p> <p>2 Turn up the display unit.</p> <p>3 Pull the air filter downward and remove it.</p> <p>4 Remove the other air filter in the same way.</p>	 <p>(R19813)</p>  <p>(R19814)</p>  <p>(R19815)</p>	
<p>2. Remove the photocatalytic air-purifying and deodorizing filter.</p> <p>1 Remove the photocatalytic air-purifying and deodorizing filter.</p>	 <p>(R19817)</p>	

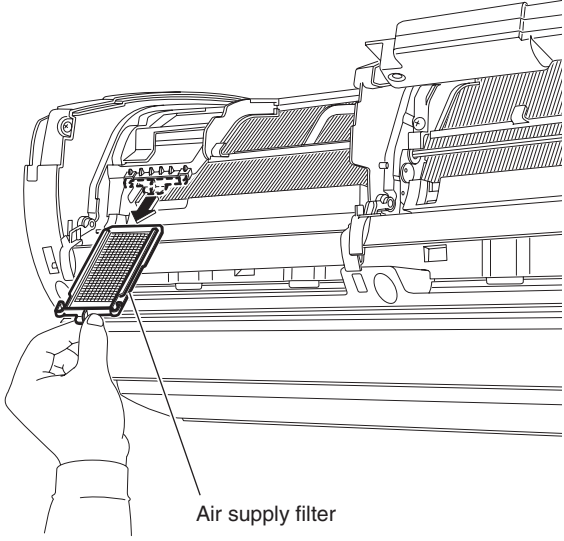
Step	Procedure	Points
3. Remove the air supply filter.	<p data-bbox="199 280 464 347">1 Remove the air supply filter.</p>  <p data-bbox="1002 846 1069 873">(R19818)</p>	

4. Front Grilles / Horizontal Blades



Warning

◆ Be sure to wait for 10 minutes or more after turning off all power supplies before disassembling work.

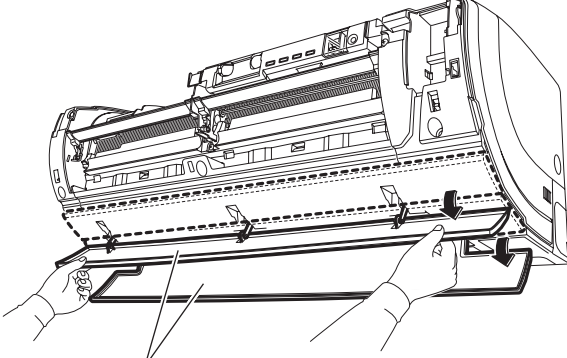
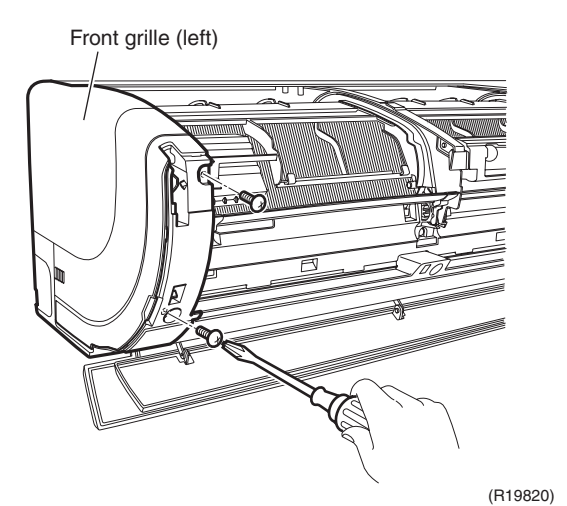
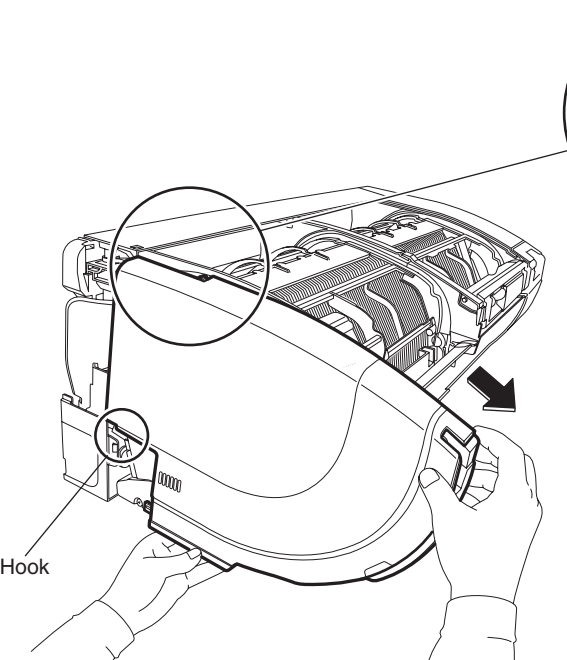
Step	Procedure	Points
1. Remove the front grille (left).	 <p data-bbox="576 781 735 808">Horizontal blade</p> <p data-bbox="995 835 1066 853">(R19819)</p>	
1 Open the 2 horizontal blades.	 <p data-bbox="563 907 715 934">Front grille (left)</p> <p data-bbox="983 1364 1053 1382">(R19820)</p>	
2 Remove the 2 screws of the front grille (left).	 <p data-bbox="496 1957 547 1984">Hook</p> <p data-bbox="1190 1453 1241 1480">Hook</p> <p data-bbox="1217 2107 1287 2125">(R19821)</p>	
3 Unfasten the 2 hooks and remove the front grille (left).		

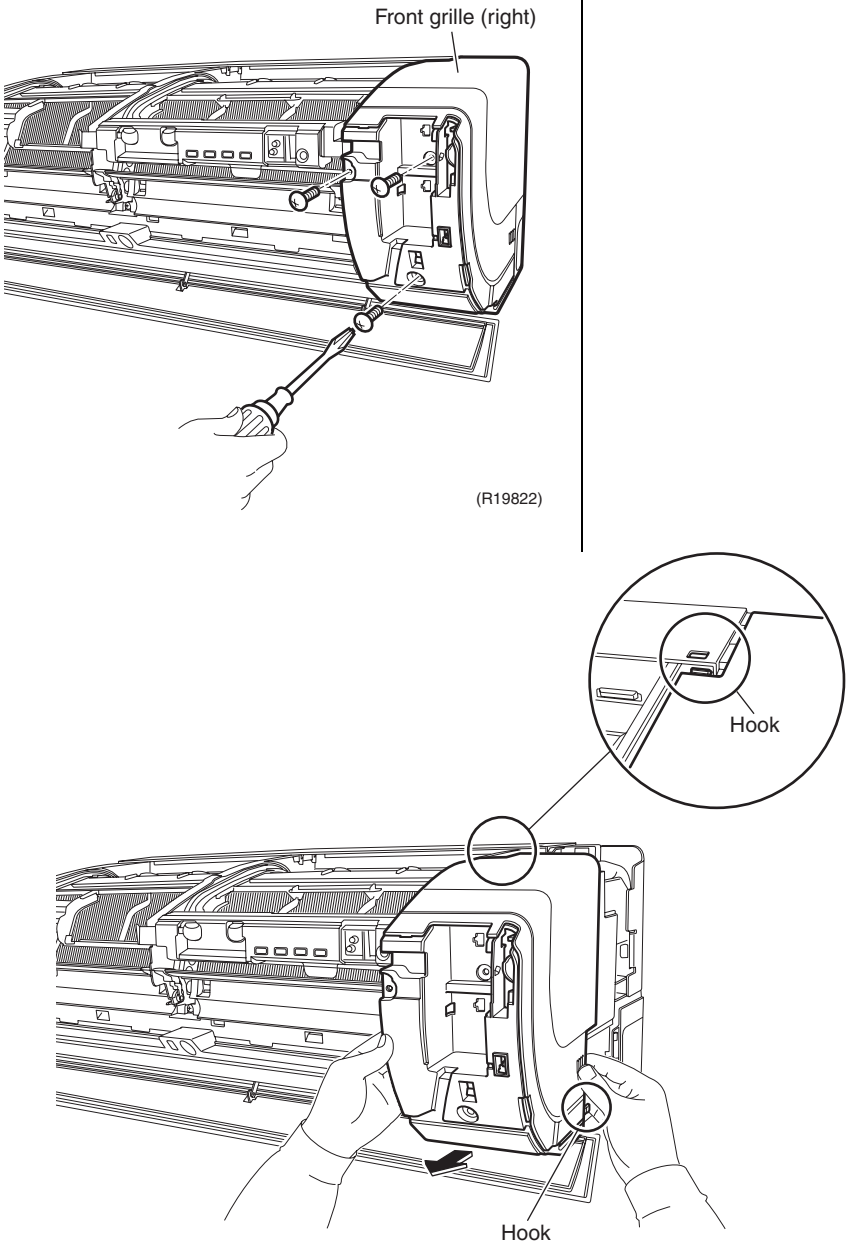
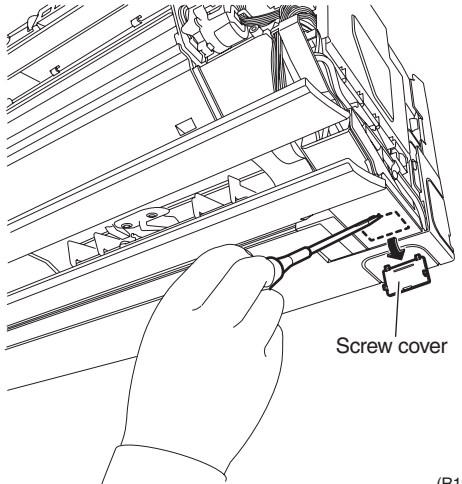
Step	Procedure	Points
<p>2. Remove the front grille (right).</p> <p>1 Remove the 3 screws of the front grille (right).</p> <p>2 Unfasten the 2 hooks and remove the front grille (right).</p>	 <p>Front grille (right)</p> <p>(R19822)</p> <p>Hook</p> <p>Hook</p> <p>(R19823)</p>	
<p>3. Remove the front grille (bottom).</p> <p>1 Remove the screw cover with a flat head screwdriver.</p>	 <p>Screw cover</p> <p>(R19824)</p>	

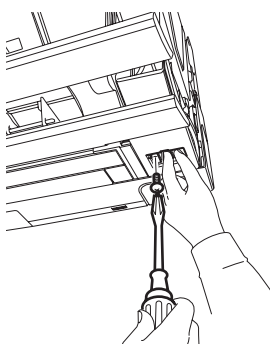
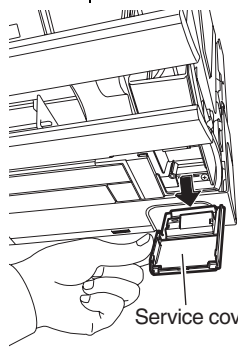
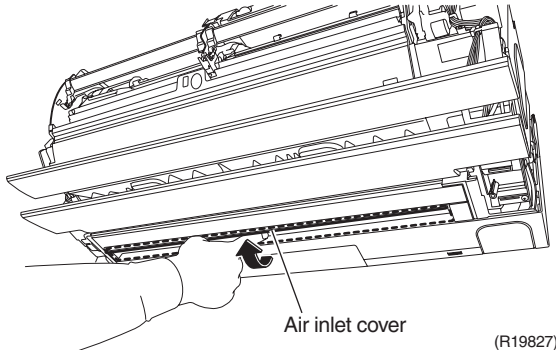
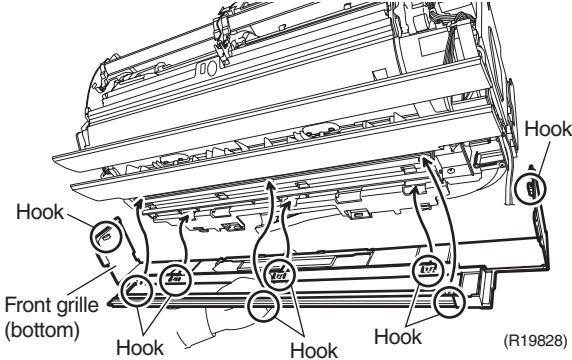
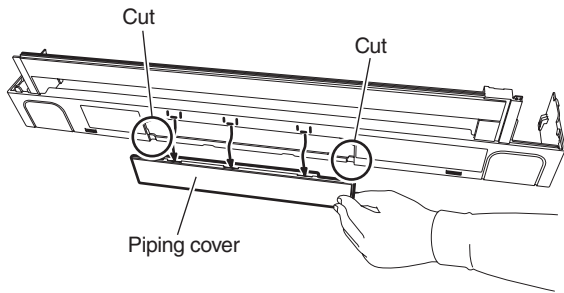
Step	Procedure	Points
2	Remove the screw and remove the service cover ASSY.  	Service cover ASSY (R19826)
3	Open the air inlet cover. 	
4	Unfasten the 8 hooks and remove the front grille (bottom).  	<ul style="list-style-type: none"> ■ If piping work is difficult, remove the piping cover and cut the front grille (bottom) to expand the opening.

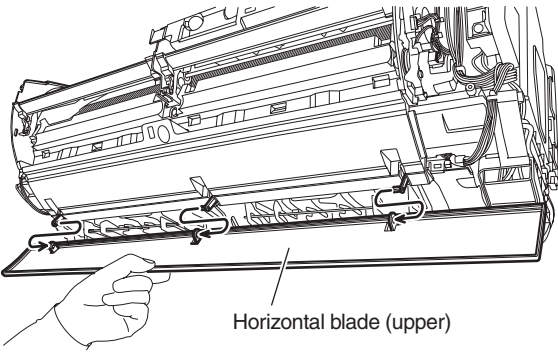
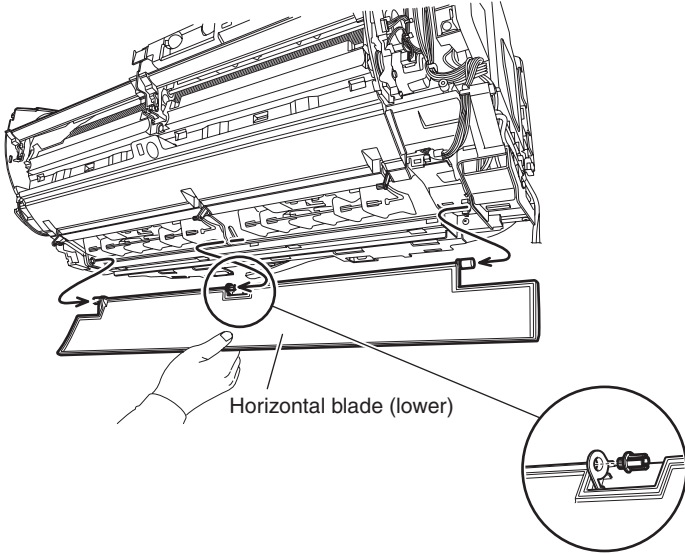
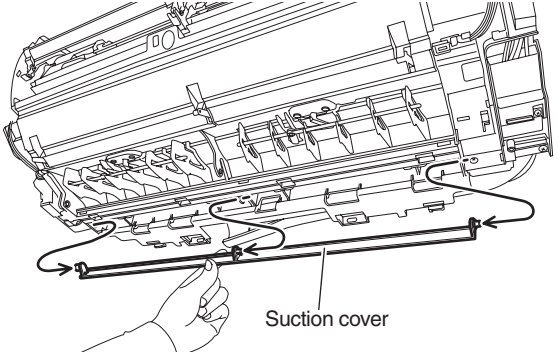
Step	Procedure	Points
<p>4. Remove the horizontal blades.</p> <p>1 Release the center shaft of the horizontal blade (upper).</p> <p>2 Release the left and right shafts and remove the horizontal blade (upper).</p> <p>3 Release the shaft of the horizontal blade (lower) in the same way.</p> <p>4 Remove the horizontal blade (lower).</p>	 <p>Horizontal blade (upper)</p> <p>(R19830)</p>  <p>Horizontal blade (lower)</p> <p>(R19831)</p>	
<p>5. Remove the suction cover.</p> <p>1 Release the shafts of the suction cover in the order of right, center, and left and remove the suction cover.</p>	 <p>Suction cover</p> <p>(R19832)</p>	

5. Electrical Box / PCBs



Warning

◆ Be sure to wait for 10 minutes or more after turning off all power supplies before disassembling work.

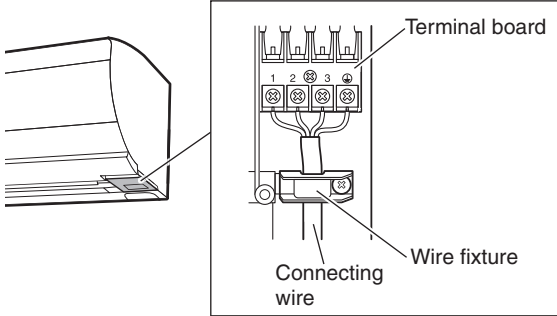
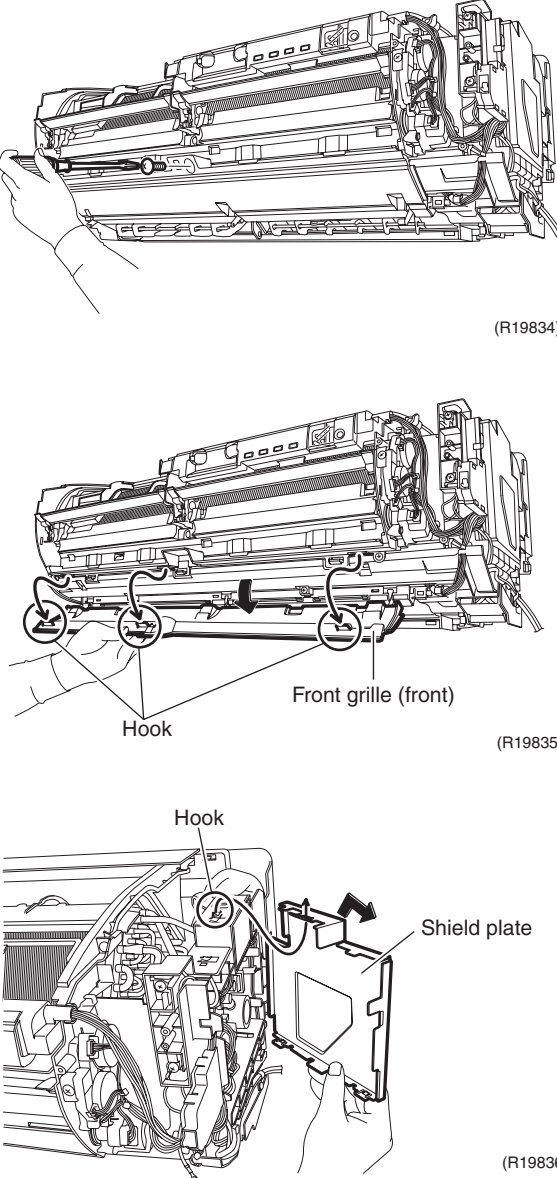
Step	Procedure	Points
<p>1. Disconnect the connecting wires.</p> <p>1 Remove the screw and remove the wire fixture.</p> <p>2 Remove the 4 screws on the terminal board and disconnect the connecting wire.</p>	 <p style="text-align: right;">(R19833)</p>	
<p>2. Remove the electrical box.</p> <p>1 Remove the screw.</p> <p>2 Unfasten the 3 hooks.</p> <p>3 Remove the front grille (front).</p> <p>4 Unfasten the hook and remove the shield plate.</p>	 <p style="text-align: right;">(R19834)</p> <p style="text-align: right;">(R19835)</p> <p style="text-align: right;">(R19836)</p>	

Step	Procedure	Points
5	Remove the screw and slightly draw out the electrical box.	
6	Release the harnesses from the 3 hooks.	
7	Disconnect the connectors [S41] [S44] [S46] and release the harnesses from the hook.	<p>[S41]: swing motors, humidity sensor PCB for humidifying</p> <p>[S44]: brush motor, filter motors, limit switch for brush</p> <p>[S46]: signal receiver / display PCB</p>
8	Remove the 2 screws.	

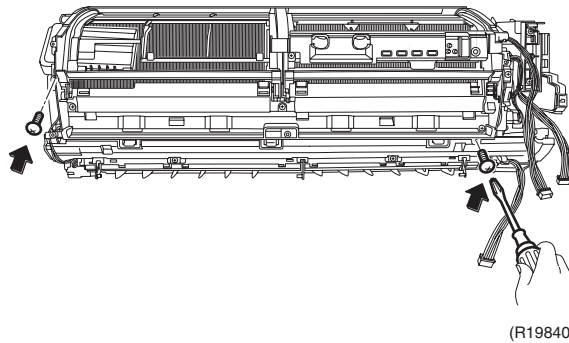
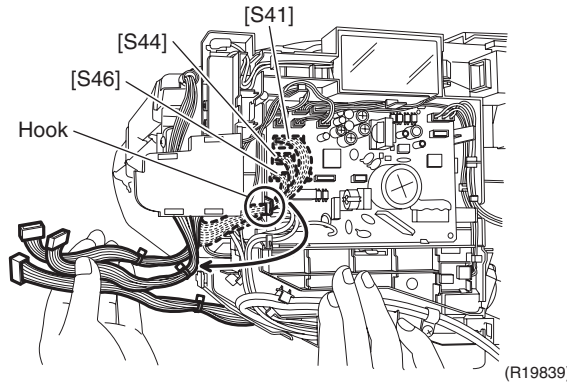
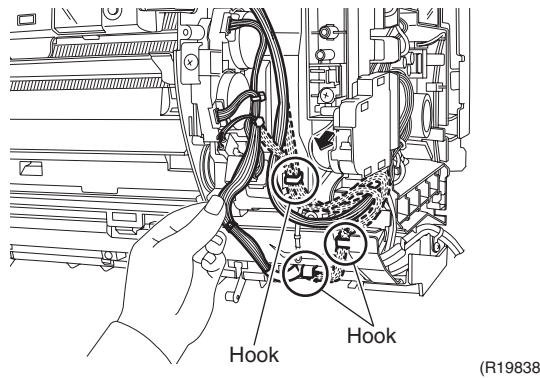
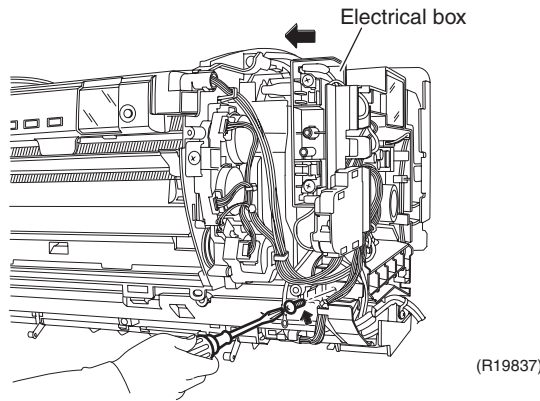

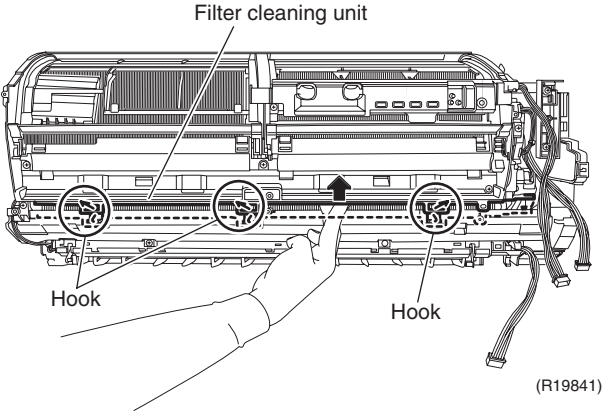
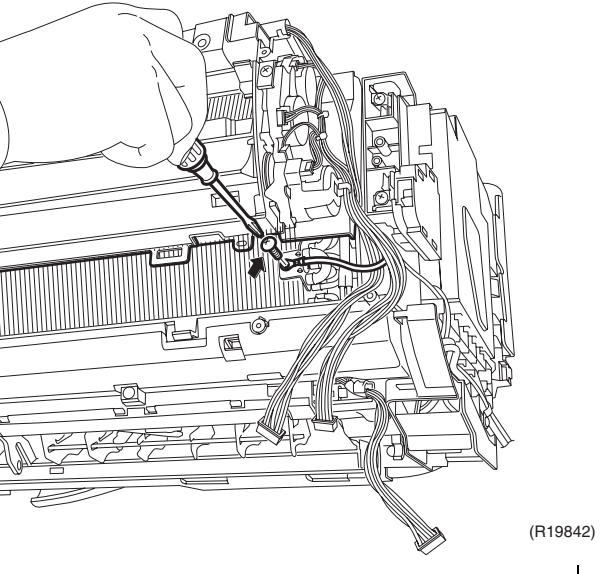
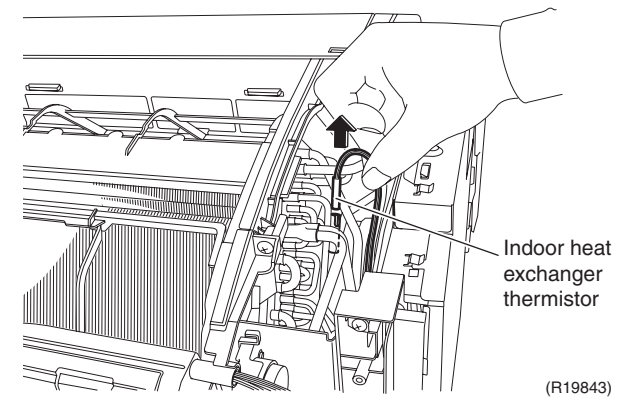
Step	Procedure	Points
9	<p>Unfasten the 3 hooks and lift the filter cleaning unit.</p> 	
10	<p>Remove the earth / ground screw.</p> 	
11	<p>Detach the indoor heat exchanger thermistor.</p> 	

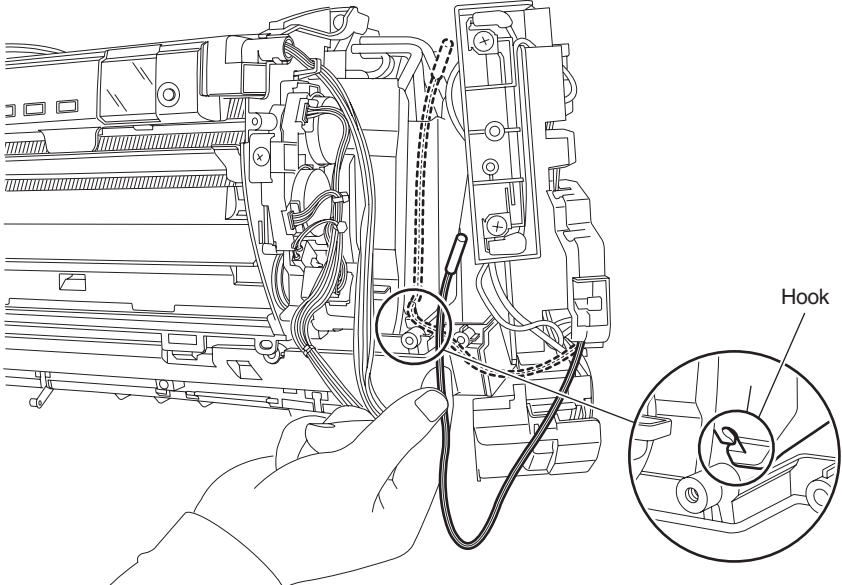
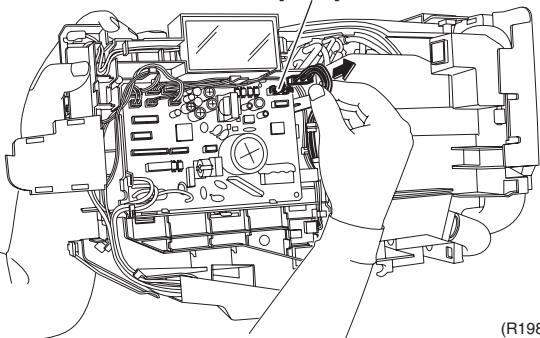
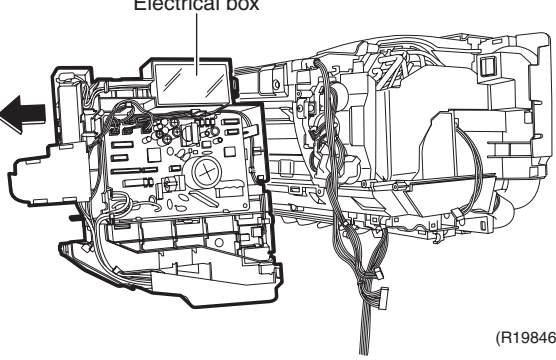
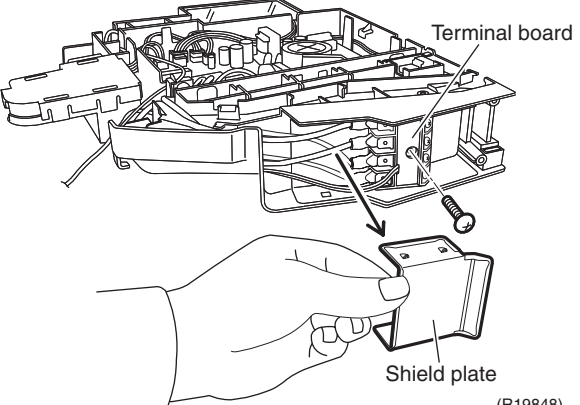
Step	Procedure	Points
12	<p>Release the harness of the indoor heat exchanger thermistor from the hook and draw the electrical box a little.</p>  <p style="text-align: right;">(R19844)</p>	
13	<p>Disconnect the connector [S200].</p>  <p style="text-align: right;">(R19845)</p>	<p>[S200]: fan motor</p>
14	<p>Remove the electrical box.</p>  <p style="text-align: right;">(R19846)</p>	
3. Remove the control PCB.		
1	<p>Remove the shield plate.</p>	
2	<p>Remove the screw and remove the terminal board.</p>  <p style="text-align: right;">(R19848)</p>	

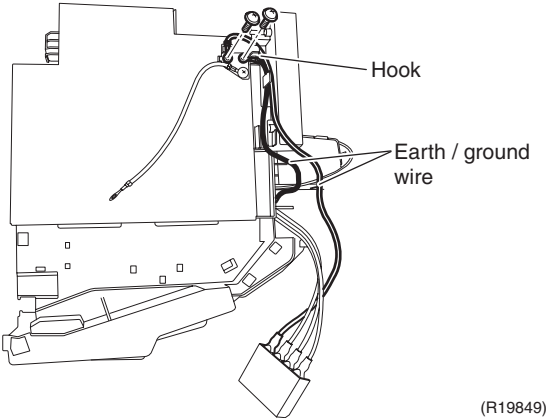
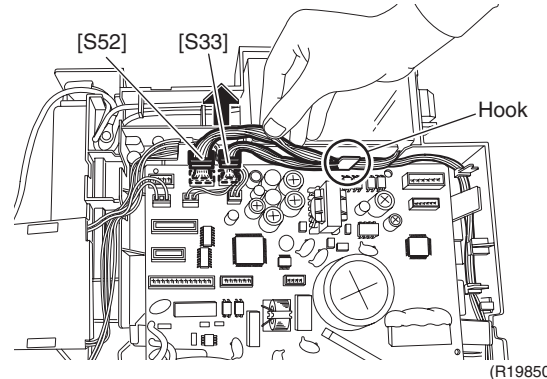
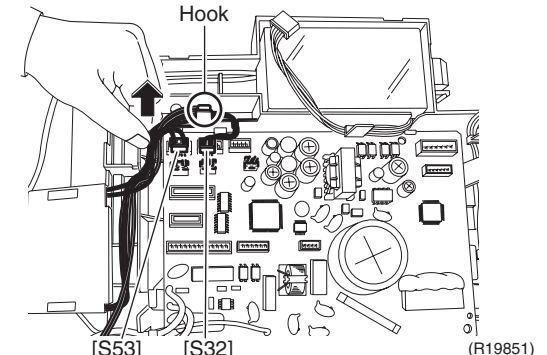
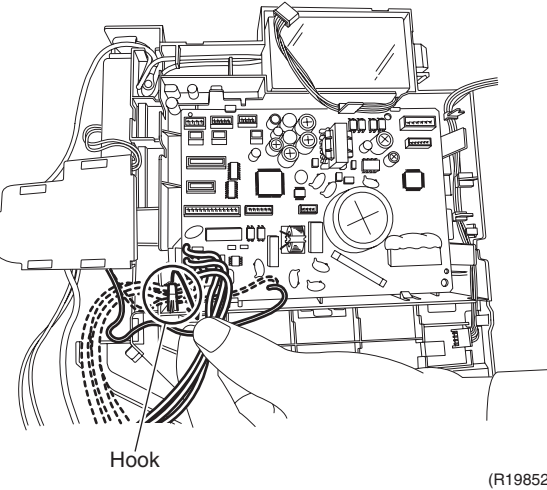
Step	Procedure	Points
3	Remove the 2 screws and remove the earth / ground wires from the hook.	
	 <p>(R19849)</p>	
4	Disconnect the connectors [S33] [S52].	[S33]: humidity sensor PCB for room
5	Release the harnesses from the hook.	[S52]: high voltage unit PCB
	 <p>(R19850)</p>	
6	Disconnect the connectors [S32] [S53].	[S32]: indoor heat exchanger thermistor
7	Release the harnesses from the hook.	[S53]: limit switch for streamer
	 <p>(R19851)</p>	
8	Release the harnesses for the terminal board from the hook.	
	 <p>(R19852)</p>	

Step	Procedure	Points
9	<p>Unfasten the 2 hooks and remove the control PCB.</p>	<p>Hook</p> <p>(R19853)</p> <p>[S53] [S52] [S41] [S44] [S46] [S52] [S33] [S200]</p> <p>(R19854)</p>
4.	<p>Remove the humidity sensor PCB for room.</p>	
1	<p>Unfasten the hook and remove the humidity sensor PCB for room.</p>	
2	<p>Disconnect the connector.</p>	<p>Connector for control PCB</p> <p>Humidity sensor PCB for room</p> <p>Hook</p> <p>(R19855)</p>

Step	Procedure	Points
5.	Remove the high voltage unit PCB.	
1	Remove the insulation sheet.	
2	Unfasten the hook and remove the high voltage unit PCB.	
3	Disconnect the connectors [S401] [B401] [CN403] and remove the high voltage unit PCB.	[S401]: for control PCB [B401][CN403]: streamer
4	Release the harnesses from the hooks.	
5	Remove the 2 screws and remove the contact switches.	

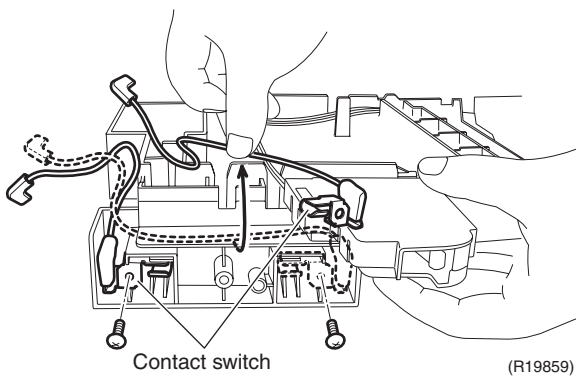
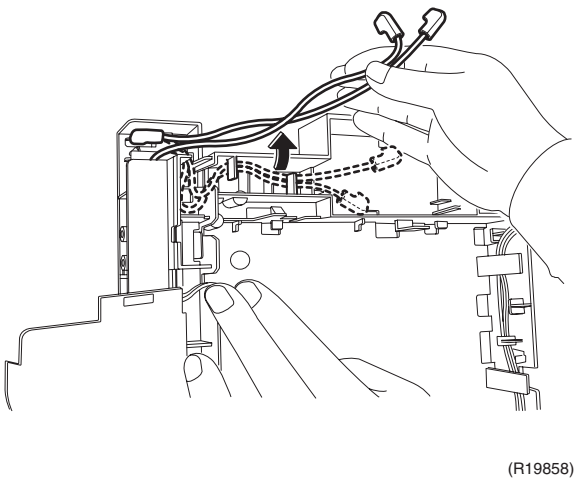
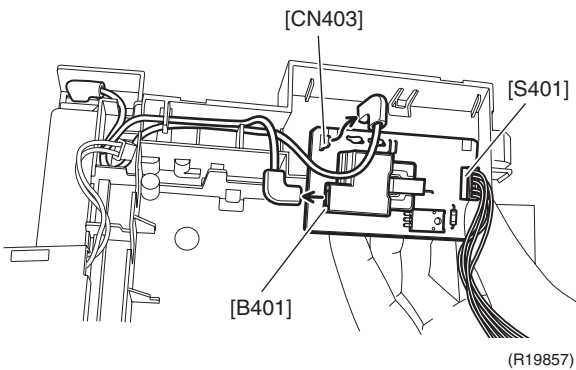
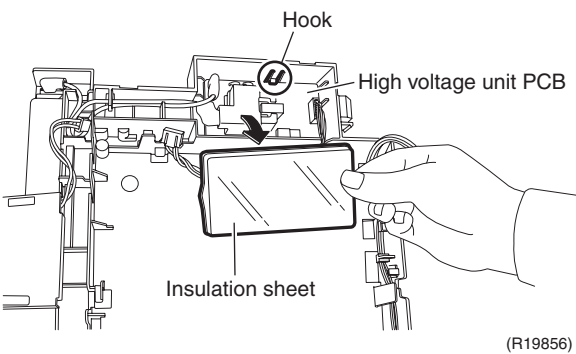

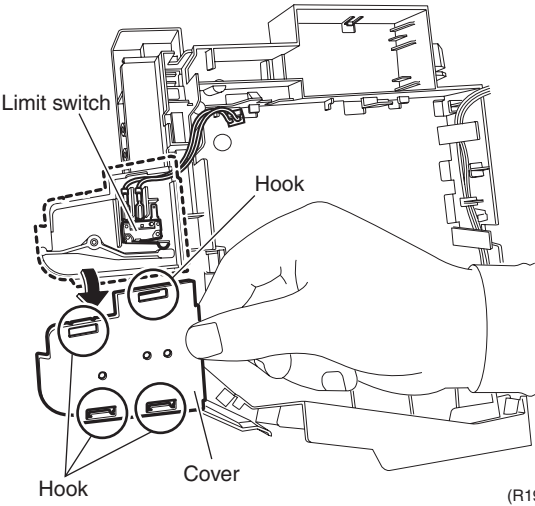
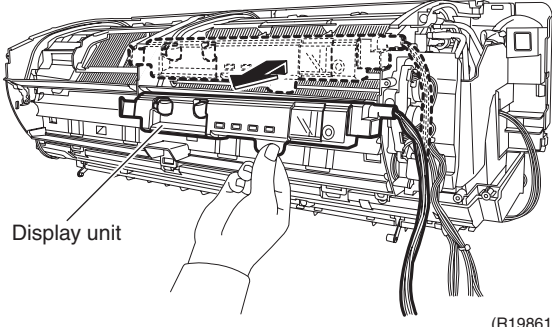
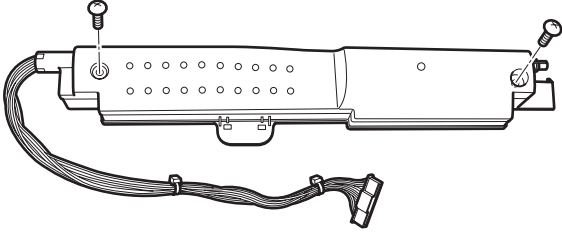
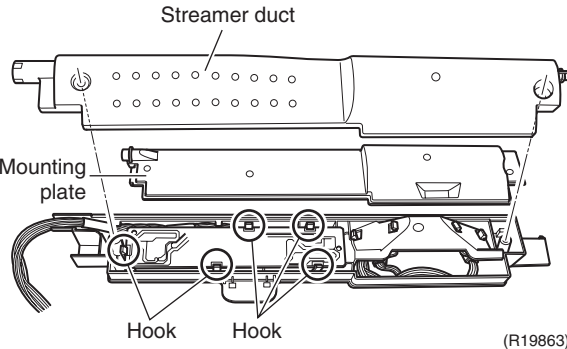
Step	Procedure	Points
6. Remove the limit switch.	<p data-bbox="153 248 456 315">1 Unfasten the 4 hooks and remove the cover.</p> <p data-bbox="153 349 392 416">2 Remove the limit switch.</p> 	
7. Remove the signal receiver / display PCB.	<p data-bbox="153 864 427 954">1 Remove the display unit from the filter cleaning unit.</p>  <p data-bbox="153 1211 448 1312">2 Remove the 2 screws on the back of the display unit.</p>  <p data-bbox="153 1637 456 1738">3 Remove the streamer duct and the mounting plate.</p> <p data-bbox="153 1771 464 1872">4 Unfasten the 5 hooks of the signal receiver / display PCB.</p> 	

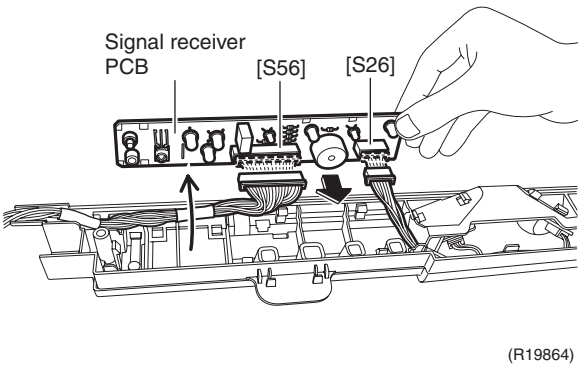
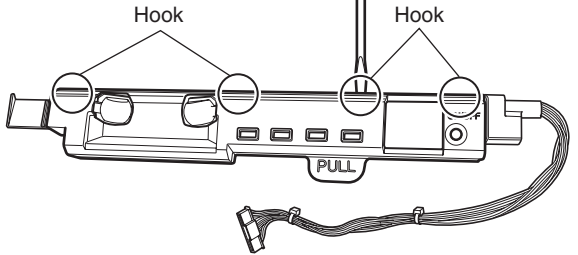
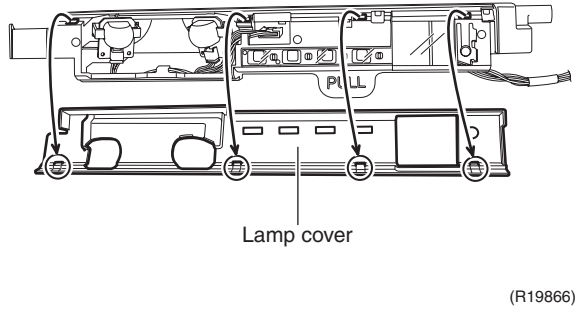
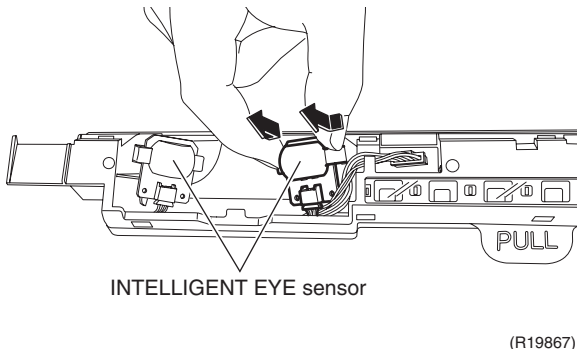
Step	Procedure	Points
<p>5 Remove the signal receiver / display PCB.</p> <p>6 Disconnect the connectors [S26] [S56].</p>		<p>[S26]: INTELLIGENT EYE sensor PCBs</p> <p>[S56]: control PCB</p>
<p>8. Remove the INTELLIGENT EYE sensors.</p>		
<p>1 Unfasten the 4 hooks and remove the lamp cover.</p>	 	
<p>2 Pinch and remove the INTELLIGENT EYE sensors.</p>		

6. Filter Cleaning Unit



Warning

- ◆ Be sure to wait for 10 minutes or more after turning off all power supplies before disassembling work.

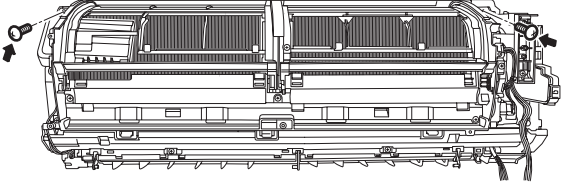
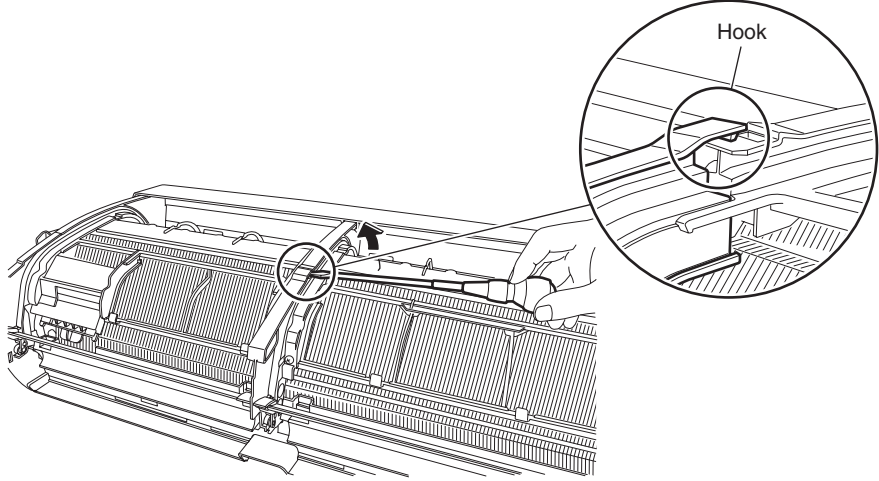
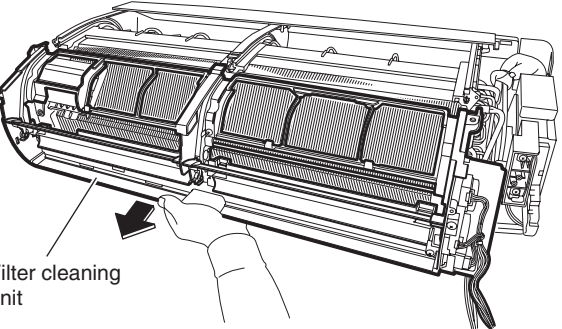
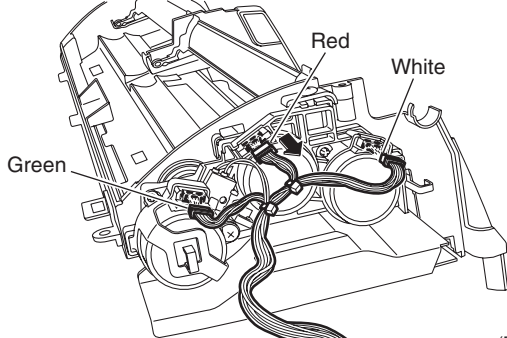
Step	Procedure	Points
1. Remove the cleaning unit.	<p data-bbox="153 412 448 472">1 Remove the 2 screws on the both side.</p>  <p data-bbox="1002 674 1070 696">(R19869)</p> <p data-bbox="153 730 424 790">2 Unfasten the center hook.</p>  <p data-bbox="1385 1263 1453 1285">(R19870)</p> <p data-bbox="153 1305 395 1366">3 Remove the filter cleaning unit.</p>  <p data-bbox="488 1599 624 1644">Filter cleaning unit</p> <p data-bbox="995 1675 1064 1697">(R19871)</p>	
2. Remove the brush motor.	<p data-bbox="153 1756 392 1816">1 Disconnect the 3 connectors.</p>  <p data-bbox="995 2085 1064 2107">(R19872)</p>	

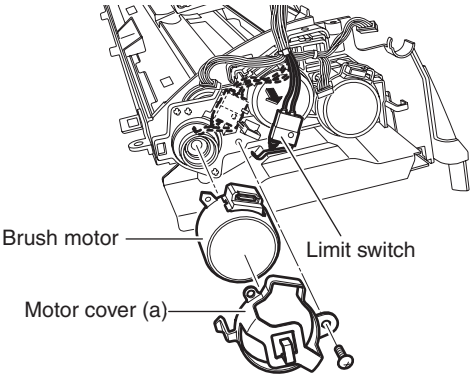
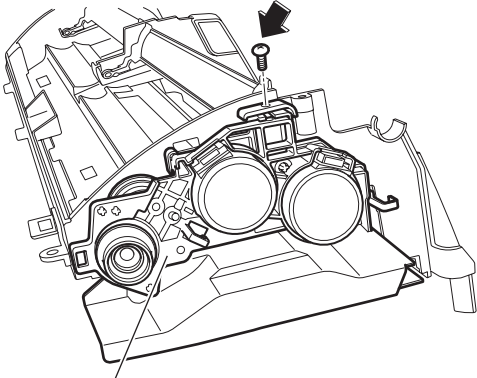
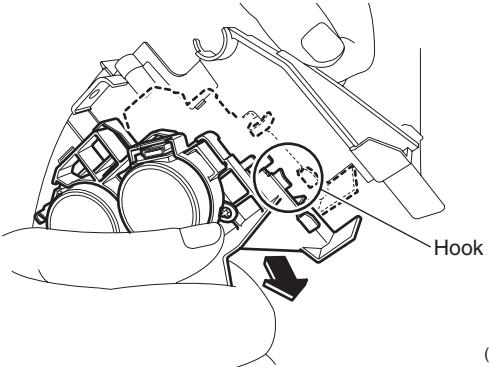
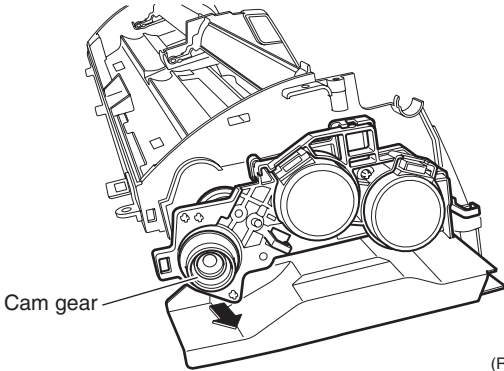
Step	Procedure	Points
<p>2 Remove the screw and remove the motor cover (a).</p> <p>3 Remove the brush motor.</p> <p>4 Remove the limit switch.</p>	 <p>Brush motor</p> <p>Limit switch</p> <p>Motor cover (a)</p> <p>(R19873)</p>	
<p>3. Remove the filter motors.</p> <p>1 Remove the screw.</p> <p>2 Unfasten the hook and remove the air filter guide motor ASSY.</p> <p>3 Remove the cam gear.</p>	 <p>Air filter guide motor ASSY</p> <p>(R19874)</p>  <p>Hook</p> <p>(R19875)</p>  <p>Cam gear</p> <p>(R19876)</p>	

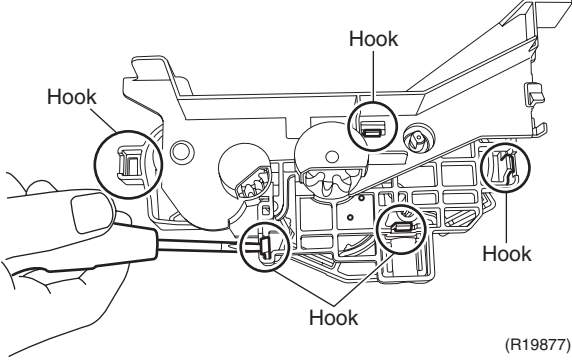
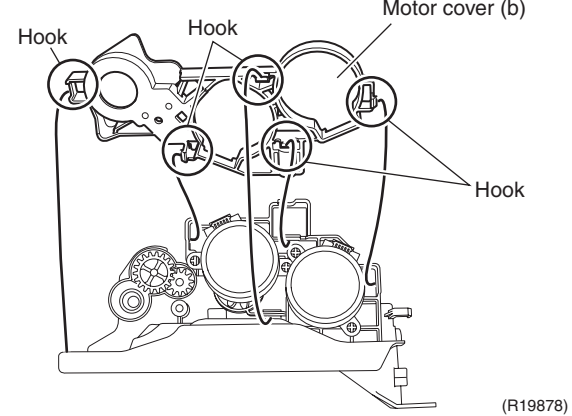
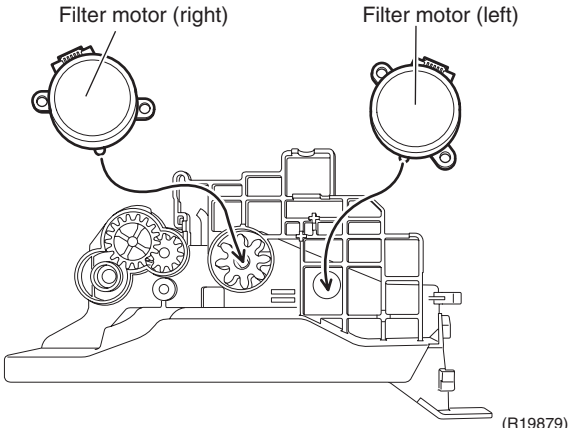
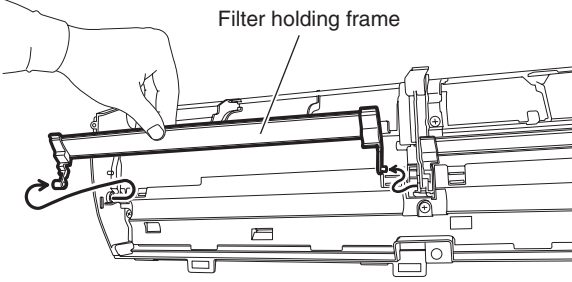
Step	Procedure	Points
4	<p data-bbox="199 217 446 275">Unfasten the 5 hooks on the back.</p>  <p data-bbox="997 593 1069 616">(R19877)</p>	
5	<p data-bbox="199 645 414 703">Remove the motor cover (b).</p>  <p data-bbox="997 1086 1069 1108">(R19878)</p>	
6	<p data-bbox="199 1149 399 1207">Remove the filter motors.</p>  <p data-bbox="997 1579 1069 1601">(R19879)</p>	
4.	<p data-bbox="199 1635 430 1693">Remove the peripheral parts.</p>	
1	<p data-bbox="199 1702 446 1827">Release the shafts on the right and left side and remove the filter holding frame.</p>  <p data-bbox="997 1993 1069 2016">(R19880)</p>	

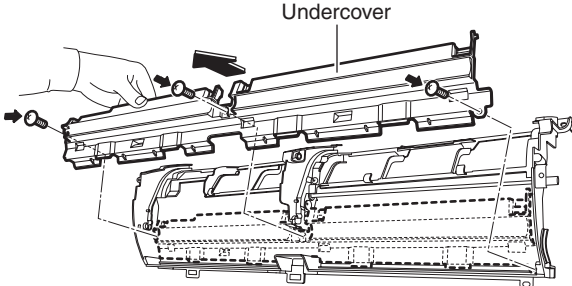
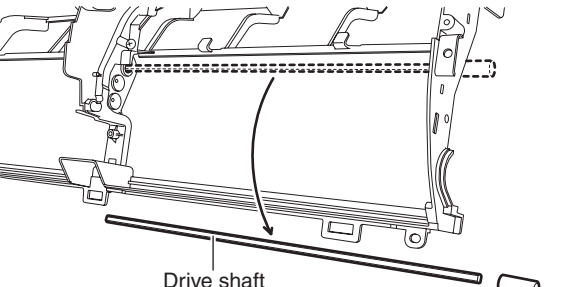
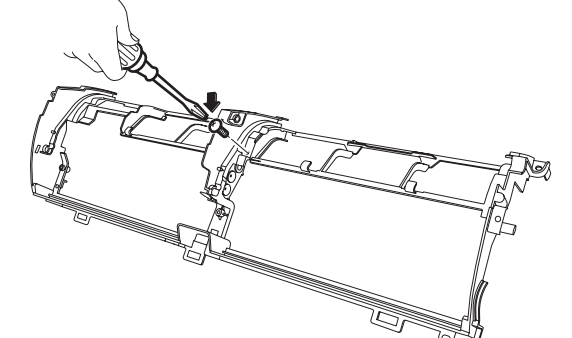
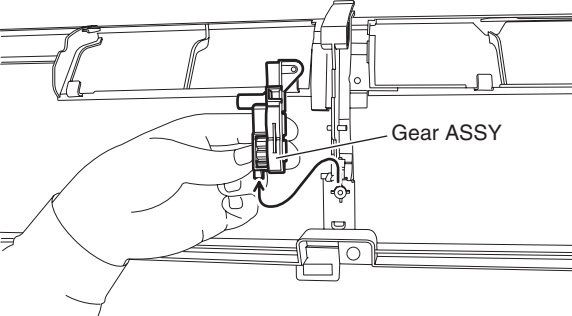



Step	Procedure	Points
2	Remove the 3 screws and remove the undercover.	
	 <p style="text-align: center;">Undercover</p> <p style="text-align: right;">(R19881)</p>	
3	Pull out the drive shaft.	
	 <p style="text-align: center;">Drive shaft</p> <p style="text-align: right;">(R19882)</p>	
4	Remove the screw.	
	 <p style="text-align: right;">(R19883)</p>	
5	Unfasten the hook and remove the gear ASSY.	
	 <p style="text-align: center;">Gear ASSY</p> <p style="text-align: right;">(R19884)</p>	

7. Humidifying Duct

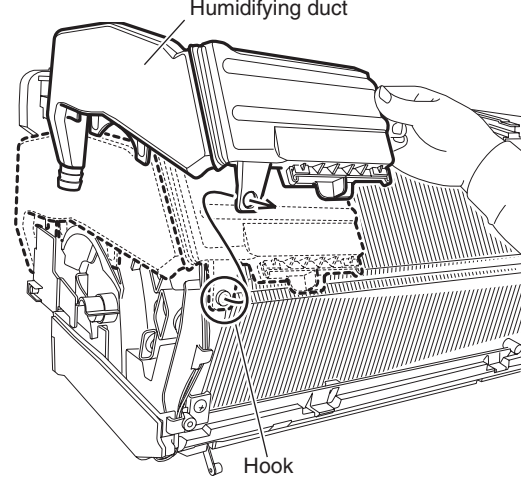
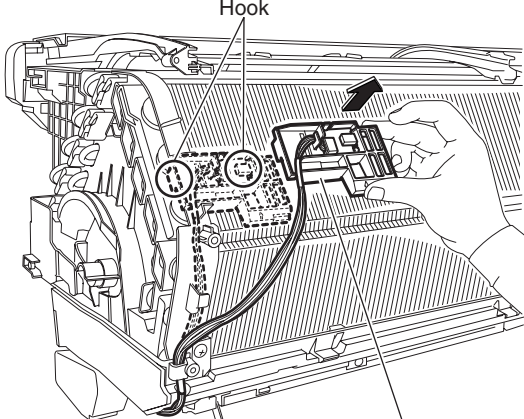
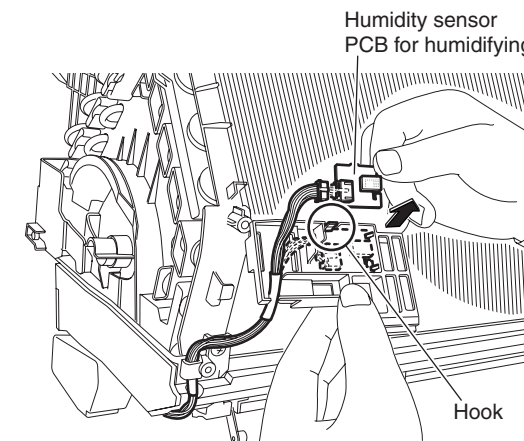

Warning

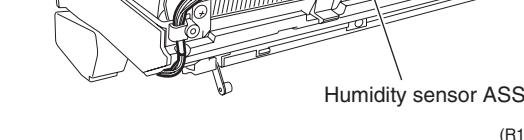
- ◆ Be sure to wait for 10 minutes or more after turning off all power supplies before disassembling work.

Step	Procedure	Points
1. Remove the humidifying duct.	 <p style="text-align: right;">(R19885)</p>	
1 Unfasten the hook and remove the humidifying duct.	 <p style="text-align: right;">(R19886)</p>	
2. Remove the humidity sensor PCB for humidifying.	 <p style="text-align: right;">(R19887)</p>	
1 Unfasten the 2 hooks on the back and remove the humidity sensor ASSY.	 <p style="text-align: right;">(R19887)</p>	
2 Unfasten the hook and remove the humidity sensor PCB for humidifying.	 <p style="text-align: right;">(R19887)</p>	
3 Disconnect the connector.	 <p style="text-align: right;">(R19887)</p>	

8. Swing Motors



Warning

◆ Be sure to wait for 10 minutes or more after turning off all power supplies before disassembling work.

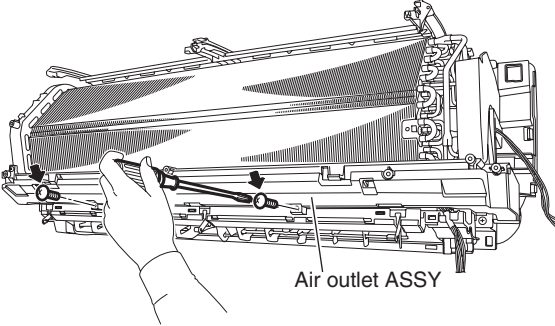
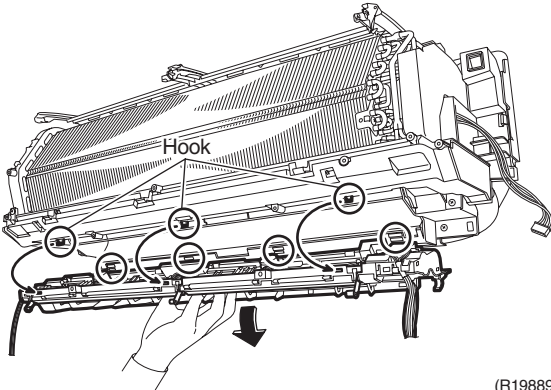
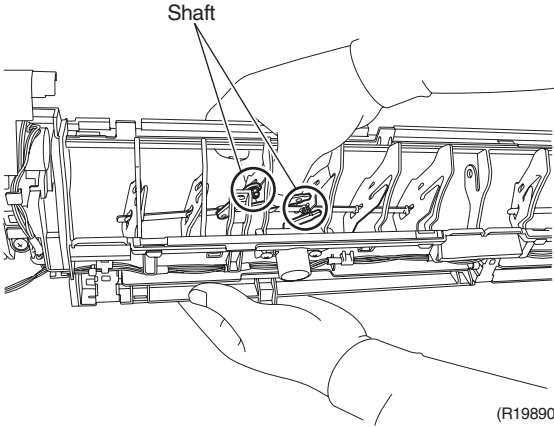
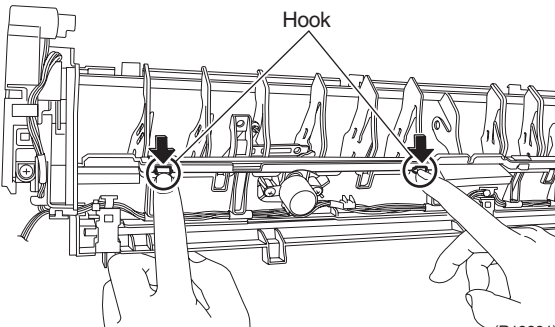
Step	Procedure	Points
1. Remove the air outlet ASSY.	 <p style="text-align: center;">Air outlet ASSY</p> <p style="text-align: right;">(R19888)</p>  <p style="text-align: center;">Hook</p> <p style="text-align: right;">(R19889)</p>	
2. Remove the vertical blade ASSY.	 <p style="text-align: center;">Shaft</p> <p style="text-align: right;">(R19890)</p>  <p style="text-align: center;">Hook</p> <p style="text-align: right;">(R19891)</p>	

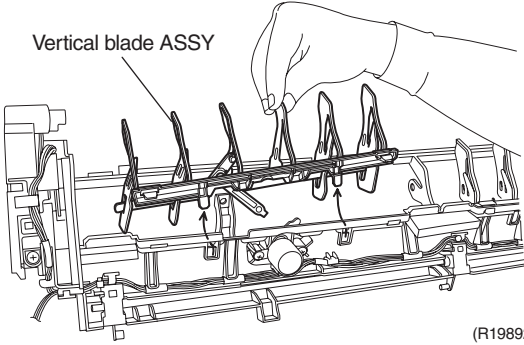
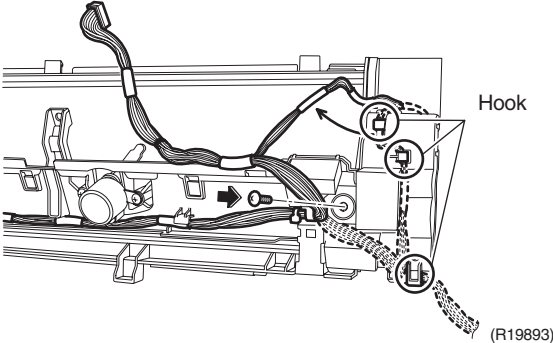
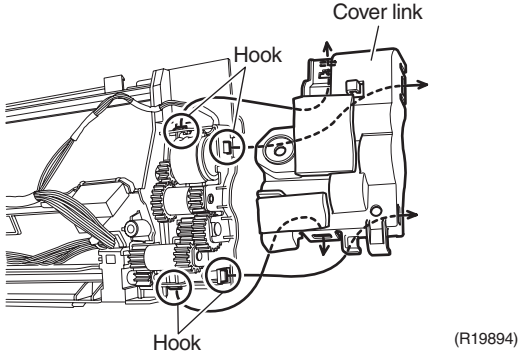
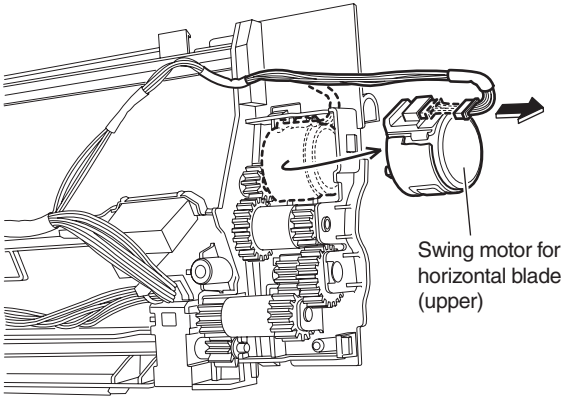
Step	Procedure	Points
3	<p>Remove the vertical blade ASSY.</p> 	
3.	<p>Remove the swing motor for horizontal blade (upper).</p>	
1	<p>Remove the screw.</p>	
2	<p>Release the harness from the 3 hooks.</p> 	
3	<p>Unfasten the 4 hooks and remove the cover link.</p> 	
4	<p>Remove the swing motor for horizontal blade (upper).</p>	
5	<p>Disconnect the connector.</p> 	<p>■ Connector color: red</p>

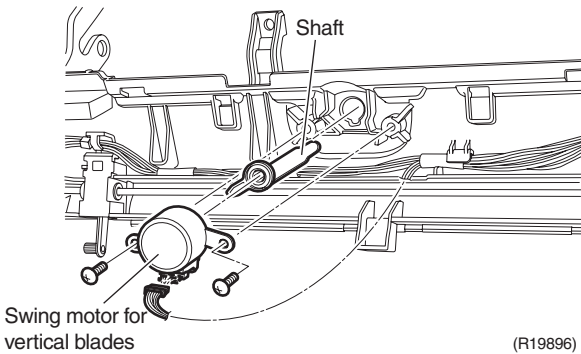
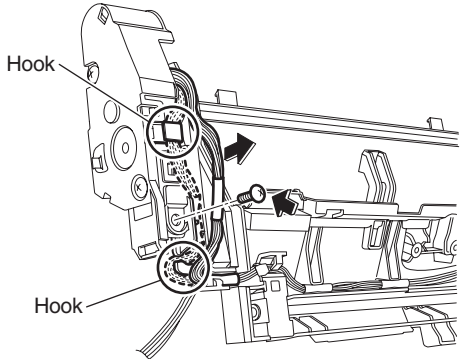
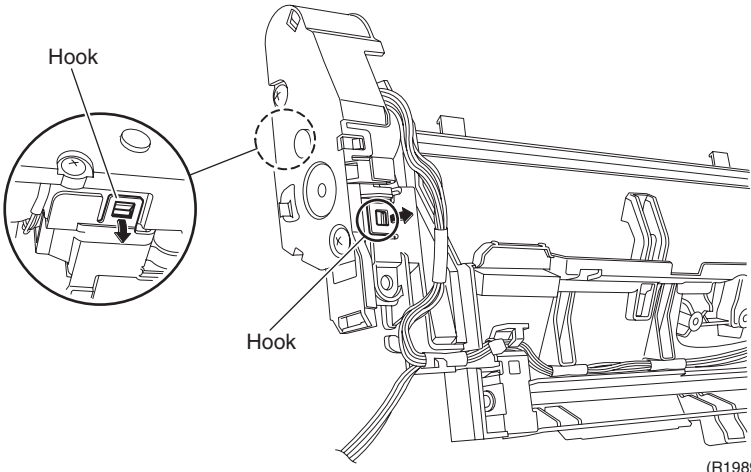
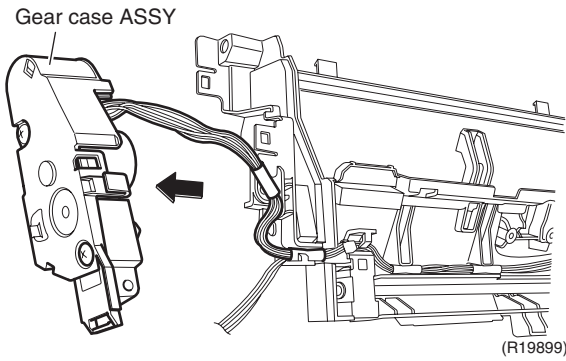
Step	Procedure	Points
<p>4. Remove the swing motors for vertical blades.</p> <p>1 Remove the 2 screws and remove the swing motor for vertical blades.</p> <p>2 Disconnect the connector.</p> <p>3 Remove the shaft.</p> <p>4 Remove the other swing motor for vertical blades in the same way.</p>	 <p>Shaft</p> <p>Swing motor for vertical blades</p> <p>(R19896)</p>	<p>■ Connector color: Right → green Left → white</p>
<p>5. Remove the swing motor for horizontal blade (lower) and the motor for suction cover.</p> <p>1 Remove the screw.</p> <p>2 Release the harness from the 2 hooks.</p> <p>3 Unfasten the 2 hooks and remove the gear case ASSY.</p>	 <p>Hook</p> <p>Hook</p> <p>(R19897)</p>  <p>Hook</p> <p>Hook</p> <p>(R19898)</p>  <p>Gear case ASSY</p> <p>(R19899)</p>	

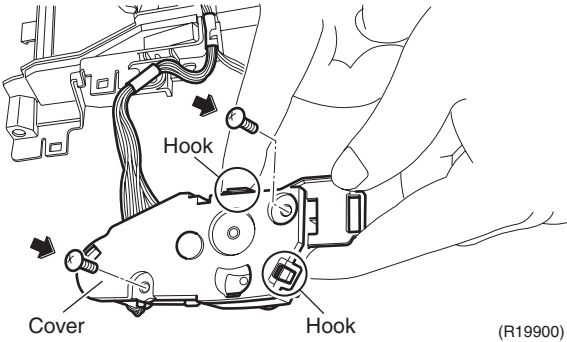
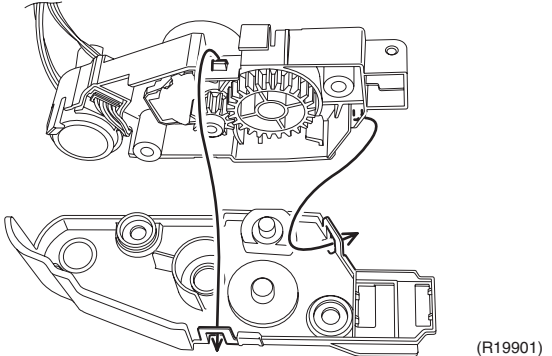
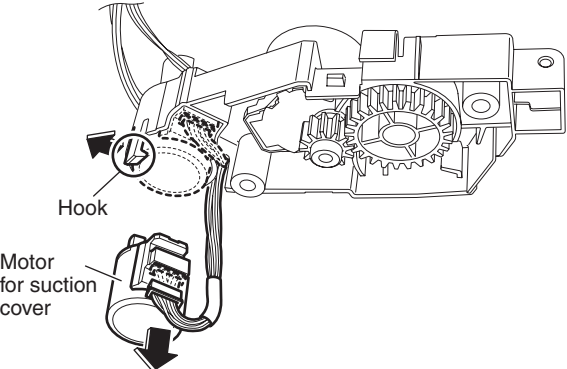
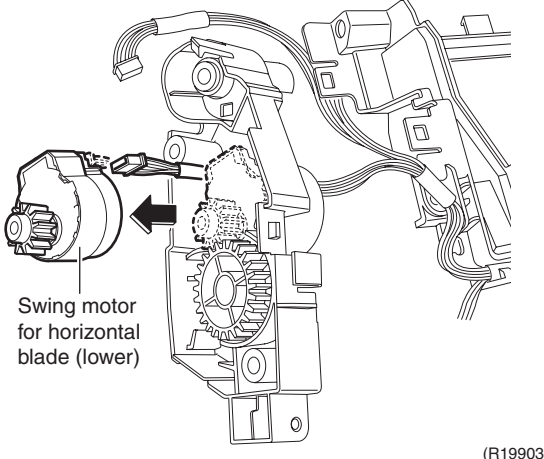
Step	Procedure	Points
4	Remove the 2 screws.	
5	Unfasten the 2 hooks and remove the cover.	
	 <p>Diagram (R19900) illustrates the initial disassembly. A hand is shown using a screwdriver to remove two screws from the cover. Two hooks are also shown being unfastened from the cover. Labels include 'Hook', 'Cover', and 'Hook'.</p>	
	 <p>Diagram (R19901) shows the cover being lifted away from the motor assembly, revealing the internal gears and components.</p>	
6	Unfasten the hook and remove the motor for suction cover.	
7	Disconnect the connector.	■ Connector color: red
	 <p>Diagram (R19902) shows the motor for the suction cover being disconnected from the main assembly. A hook is used to unfasten the motor. Labels include 'Hook' and 'Motor for suction cover'.</p>	
8	Remove the swing motor for horizontal blade (lower).	
9	Disconnect the connector.	■ Connector color: green
	 <p>Diagram (R19903) shows the swing motor for the horizontal blade being disconnected from the main assembly. Labels include 'Swing motor for horizontal blade (lower)'.</p>	

9. Indoor Heat Exchanger



Warning

- ◆ Be sure to wait for 10 minutes or more after turning off all power supplies before disassembling work.
- ◆ In pump-down work, be sure to stop the compressor before disconnecting the refrigerant pipe. If the refrigerant pipe is disconnected with the compressor operating and the stop valve open, air may be sucked in and may generate an over-pressure in refrigeration cycle, thus resulting in pipe rupture or accidental injury.
- ◆ When removing or reinstalling the indoor heat exchanger, be sure to wear gloves or wrap the indoor heat exchanger with cloths. (You may be injured by the fins.)



Caution

- ◆ Be sure to conduct pump down operation before disassembling the refrigerant pipe.
- ◆ If the refrigerant leaks, repair the spot of leaking, then collect all refrigerant from the unit. After conducting vacuum drying, recharge proper amount of refrigerant.
- ◆ From the viewpoint of global environmental protection, make sure to use a vacuum pump for air purging.

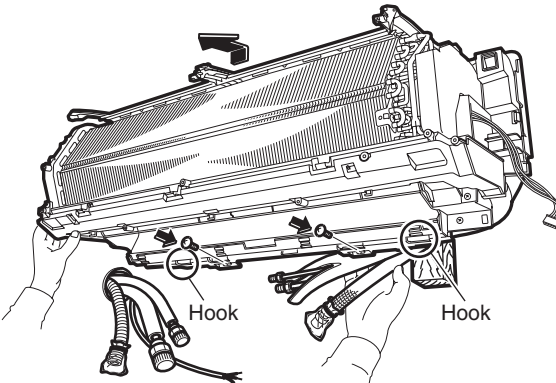
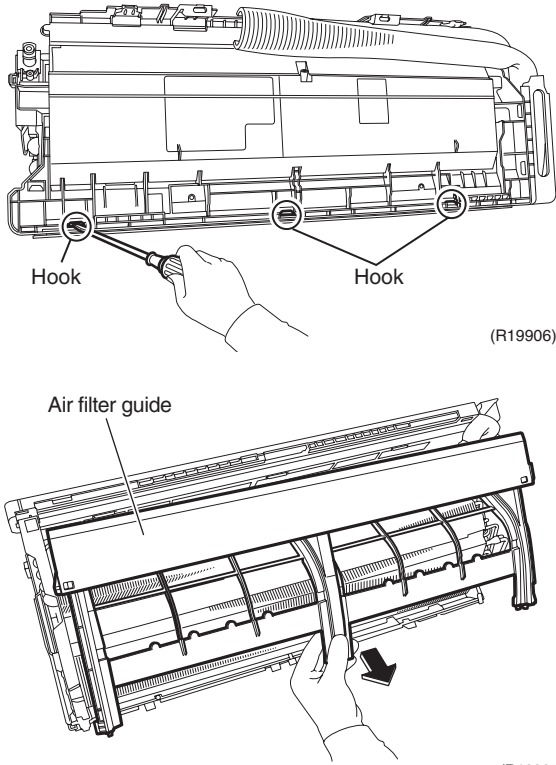
Step	Procedure	Points
<p>1. Detach the indoor unit.</p> <p>1 Remove the 2 screws which fix the indoor unit to the installation plate.</p> <p>2 Unfasten the 2 hooks and detach the indoor unit from the installation plate.</p>	 <p style="text-align: right;">(R19905)</p>	
<p>2. Remove the air filter guide.</p> <p>1 Unfasten the 3 hooks and remove the air filter guide.</p>	 <p style="text-align: right;">(R19906)</p> <p style="text-align: right;">(R19907)</p>	

Step	Procedure	Points
3.	Remove the indoor heat exchanger.	
1	Unfasten the 3 hooks and remove the piping fixture.	
2	Slightly widen the auxiliary piping.	
3	Remove the screw and remove the drain hose.	
4	Remove the screw.	
5	Unfasten the hook while pushing from behind.	

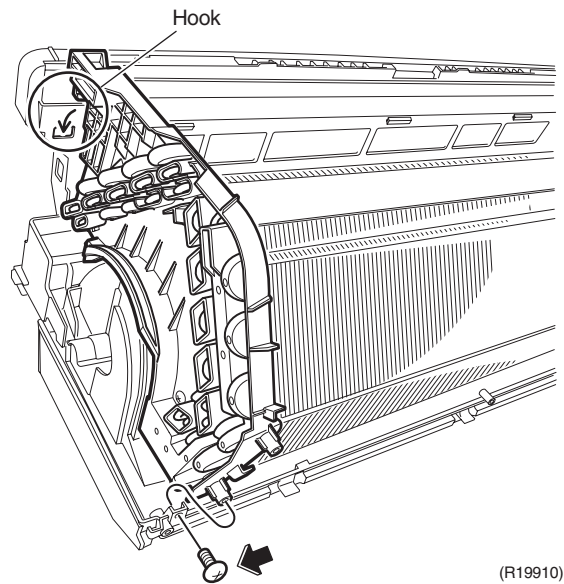
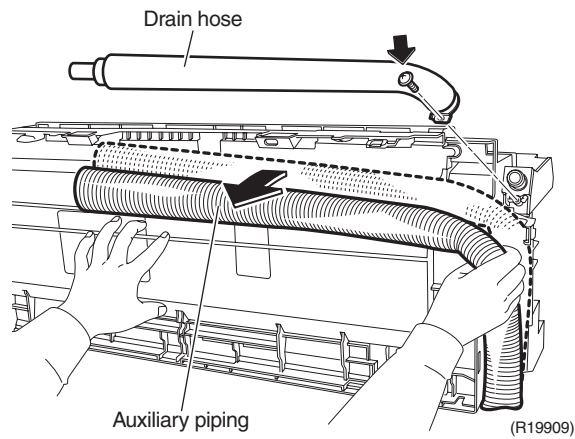
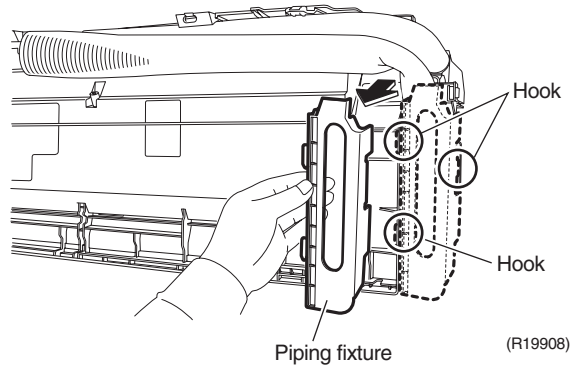

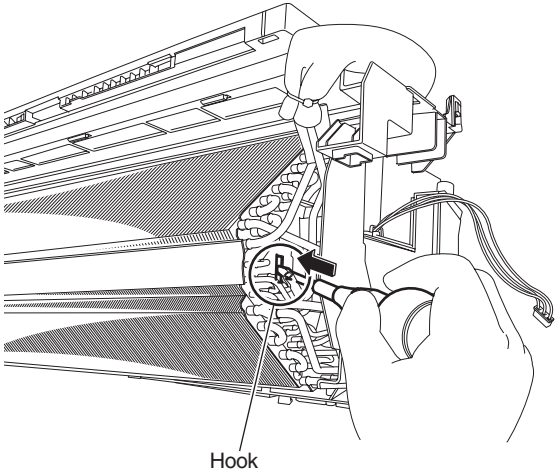
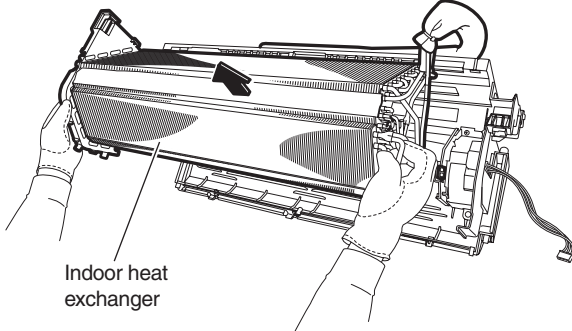
Step	Procedure	Points
6	<p data-bbox="201 215 464 309">Unfasten the hook and remove the indoor heat exchanger.</p>  <p data-bbox="699 703 751 728">Hook</p> <p data-bbox="979 813 1050 837">(R19911)</p>  <p data-bbox="555 1151 660 1200">Indoor heat exchanger</p> <p data-bbox="995 1344 1066 1368">(R19912)</p>	

10. Fan Rotor / Fan Motor



Warning

- ◆ Be sure to wait for 10 minutes or more after turning off all power supplies before disassembling work.

Step	Procedure	Points
1	Remove the 2 screws and remove the right side panel.	
2	Remove the 4 screws of the drain pan ASSY.	
3	Unfasten the hook and remove the drain pan ASSY.	
4	Release the harness from the hook.	
5	Lift up and remove the fan rotor.	

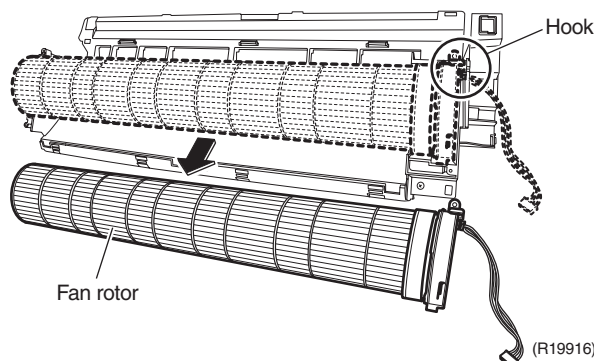
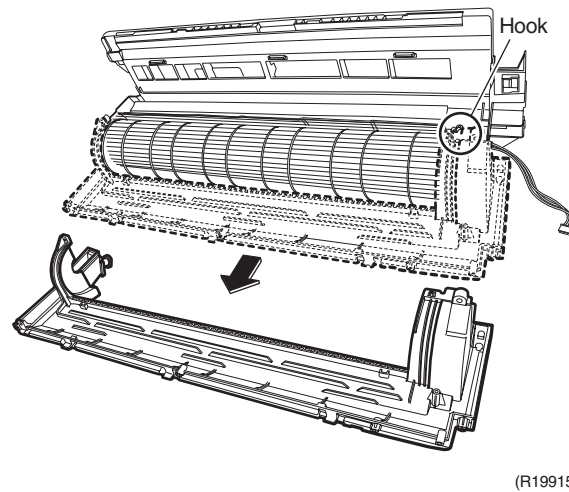
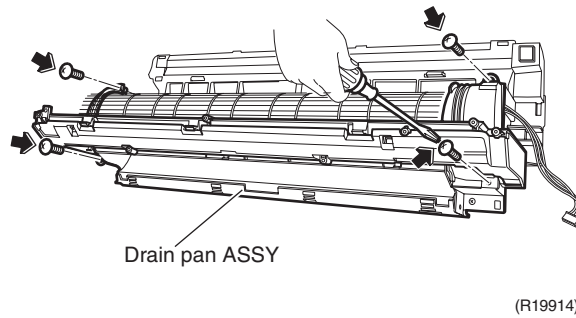
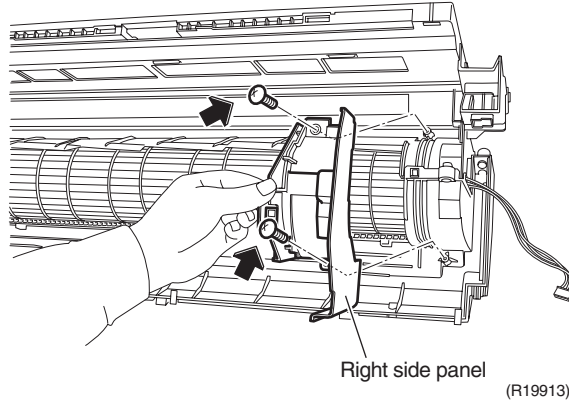

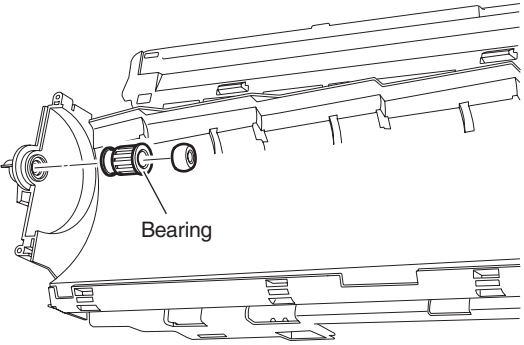
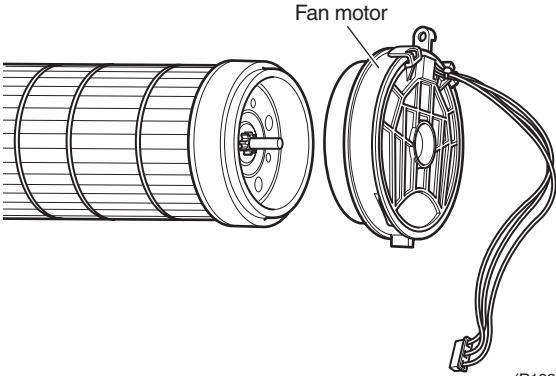
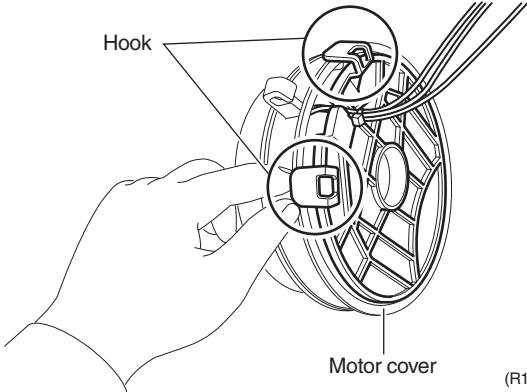
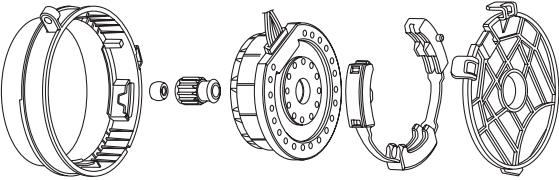
Step	Procedure	Points
6	Remove the bearing.	
	 <p style="text-align: right;">(R19917)</p>	
7	Pull out the fan motor.	<ul style="list-style-type: none"> ■ The magnet of the motor is united with the fan rotor. Be careful not to attract metal waste to the magnet. Keep away from the materials that can be affected by magnetic force also.
	 <p style="text-align: right;">(R19918)</p>	
8	Unfasten the 2 hooks and remove the motor cover.	
	 <p style="text-align: right;">(R19919)</p>  <p style="text-align: right;">(R20348)</p>	

Revision History

Month / Year	Version	Revised contents
03 / 2014	Si041361E	First edition

Warning



- Daikin products are manufactured for export to numerous countries throughout the world. Prior to purchase, please confirm with your local authorised importer, distributor and/or retailer whether this product conforms to the applicable standards, and is suitable for use, in the region where the product will be used. This statement does not purport to exclude, restrict or modify the application of any local legislation.
- Ask a qualified installer or contractor to install this product. Do not try to install the product yourself. Improper installation can result in water or refrigerant leakage, electrical shock, fire or explosion.
- Use only those parts and accessories supplied or specified by Daikin. Ask a qualified installer or contractor to install those parts and accessories. Use of unauthorised parts and accessories or improper installation of parts and accessories can result in water or refrigerant leakage, electrical shock, fire or explosion.
- Read the User's Manual carefully before using this product. The User's Manual provides important safety instructions and warnings. Be sure to follow these instructions and warnings.

If you have any enquiries, please contact your local importer, distributor and/or retailer.

Cautions on product corrosion

1. Air conditioners should not be installed in areas where corrosive gases, such as acid gas or alkaline gas, are produced.
2. If the outdoor unit is to be installed close to the sea shore, direct exposure to the sea breeze should be avoided. If you need to install the outdoor unit close to the sea shore, contact your local distributor.

Dealer

DAIKIN INDUSTRIES, LTD.

Head Office:
Umeda Center Bldg., 2-4-12, Nakazaki-Nishi,
Kita-ku, Osaka, 530-8323 Japan

Tokyo Office:
JR Shinagawa East Bldg., 2-18-1, Konan,
Minato-ku, Tokyo, 108-0075 Japan

<http://www.daikin.com>

©All rights reserved