



Air Conditioning Technical Data



EEDEN13-100

RXS-F

TABLE OF CONTENTS

RXS-F

1	Features	2
2	Specifications	3
	Nominal Capacity And Nominal Input	3
	Technical Specifications	6
	Electrical Specifications	8
3	Electrical data	9
	Electrical Data	9
4	Capacity tables	12
	Cooling/Heating Capacity Tables	12
5	Dimensional drawings	19
	Dimensional Drawings	19
6	Centre of gravity	20
	Centre of Gravity	20
7	Piping diagrams	21
	Piping Diagrams	21
8	Wiring diagrams	22
	Wiring Diagrams - Single Phase	22
9	Sound data	23
	Sound Pressure Spectrum - Cooling	23
	Sound Pressure Spectrum - Heating	24
10	Operation range	25
	Operation Range	25

1 Features

- Outdoor units for pair application
- Energy saving during standby mode: reduces current consumption by about 80% when operating in standby. If no people are detected for more than 20 minutes, the system will automatically switch to the current-saving mode.
- Daikin outdoor units are neat, sturdy and can easily be mounted on a roof or terrace or simply placed against an outside wall
- Outdoor unit silent operation: "silent" button on the remote control lowers the operation sound of the outdoor unit by 3dBA to ensure a quiet environment for the neighbourhood.
- Outdoor units are fitted with a swing compressor, renowned for its low noise and high energy efficiency



Inverter



Energy saving during standby mode



Auto cooling-heating changeover



Outdoor unit silent operation

2 Specifications

2-1 Nominal Capacity And Nominal Input				FTXS60G/RXS60F		FTXS71G/RXS71F	
Cooling capacity	Min.	kW		1.7	2.3		
		Btu/h		5,800	7,800		
	Nom.	kW		6.0 (2)	7.1 (2)		
		Btu/h		20,500 (2)	24,200 (2)		
	Max.	kW		6.7	8.5		
		Btu/h		22,900	29,000		
Heating capacity	Min.	kW		1.7	2.3		
		Btu/h		5,800	7,800		
	Nom.	kW		7.0 (3)	8.2 (3)		
		Btu/h		23,900 (3)	28,000 (3)		
	Max.	kW		8.0	10.2		
		Btu/h		27,300	34,800		
Seasonal efficiency (according to EN14825)	Cooling	Energy label		A			
		Pdesign	kW	6.00	7.10		
		SEER		5.35	5.23		
		Annual energy consumption	kWh	393	475		
	Heating (Average climate)	Energy label		A			
		Pdesign	kW	4.80	6.50		
		SCOP		3.75	3.50		
		Annual energy consumption	kWh	1,790	2,593		
Nominal efficiency (cooling at 35°/27° nominal load, heating at 7°/20° nominal load)	EER		3.02				
	COP		3.43	3.22			
	Annual energy consumption		kWh	995	1,175		
	Energy label	Cooling		B			
		Heating		B	C		
Piping connections	Liquid	OD	mm	6.35			
	Gas	OD	mm	12.7	15.9		
	Drain	OD	mm	18.0			
	Heat insulation		Both liquid and gas pipes				

Notes

- (1) EER/COP according to Eurovent 2012
- (2) Cooling: indoor temp. 27°CDB, 19.0°CWB; outdoor temp. 35°CDB, 24°CWB; equivalent piping length: 5m
- (3) Heating: indoor temp. 20°CDB; outdoor temp. 7°CDB, 6°CWB; equivalent refrigerant piping: 5m

2-2 Nominal Capacity And Nominal Input				FDXS60F/RXS60F	
Cooling capacity	Min.	kW		1.7	
		Btu/h		5,800	
		kcal/h		1,460	
	Nom.	kW		6.0 (2)	
		Btu/h		20,500 (2)	
		kcal/h		5,160 (2)	
	Max.	kW		6.5	
		Btu/h		22,200	
		kcal/h		5,590	
Heating capacity	Min.	kW		1.7	
		Btu/h		5,800	
		kcal/h		1,460	
	Nom.	kW		7.0 (3)	
		Btu/h		23,900 (3)	
		kcal/h		6,020 (3)	
	Max.	kW		8.0	
		Btu/h		27,300	
		kcal/h		6,880	

2 Specifications

2

2-2 Nominal Capacity And Nominal Input				FDXS60F/RXS60F
Seasonal efficiency (according to EN14825)	Cooling	Energy label		A
		Pdesign	kW	6.00
		SEER		5.50
		Annual energy consumption	kWh	382
	Heating (Average climate)	Energy label		A
		Pdesign	kW	4.00
		SCOP		3.51
		Annual energy consumption	kWh	1,596
Nominal efficiency (cooling at 35°/27° nominal load, heating at 7°/20° nominal load)	EER			2.91 (1)
	COP			3.21 (1)
	Annual energy consumption		kWh	1,030
	Energy label	Cooling		C
		Heating		C
Piping connections	Liquid	OD	mm	6.35
	Gas	OD	mm	12.7
	Heat insulation			Both liquid and gas pipes
Current	Nominal running current (RLA) - 50Hz	Cooling	A	9.2
		Heating	A	10.0

Notes

- (1) EER/COP according to Eurovent 2012
 (2) Cooling: indoor temp. 27°CDB, 19.0°CWB; outdoor temp. 35°CDB, 24°CWB; equivalent piping length: 5m
 (3) Heating: indoor temp. 20°CDB; outdoor temp. 7°CDB, 6°CWB; equivalent refrigerant piping: 5m

2-3 Nominal Capacity And Nominal Input				FCQG60F/RXS60F
Cooling capacity	Nom.		kW	5.70
Heating capacity	Nom.		kW	7.00
Seasonal efficiency (according to EN14825)	Cooling	Energy label		A+
		Pdesign	kW	5.70
		SEER		5.74
		Annual energy consumption	kWh	347
	Heating (Average climate)	Energy label		A
		Pdesign	kW	4.71
		SCOP		3.87
		Annual energy consumption	kWh	1,704
Nominal efficiency (cooling at 35°/27° nominal load, heating at 7°/20° nominal load)	EER			3.48
	COP			3.52
	Annual energy consumption		kWh	820
	Energy label	Cooling		A
		Heating		B
Piping connections	Liquid	OD	mm	6.35
	Gas	OD	mm	12.7
	Heat insulation			Both liquid and gas pipes
Current	Nominal running current (RLA) - 50Hz	Cooling	A	9.6

Notes

- (1) EER/COP according to Eurovent 2012

4

2 Specifications

2-4 Nominal Capacity And Nominal Input			FBQ60C8/RXS60F	
Cooling capacity	Nom.	kW	5.70	
Heating capacity	Nom.	kW	7.00	
Seasonal efficiency (according to EN14825)	Cooling	Energy label		A
		Pdesign	kW	6.00
		SEER		5.17
		Annual energy consumption	kWh	406
	Heating (Average climate)	Energy label		A
		Pdesign	kW	4.80
		SCOP		3.43
		Annual energy consumption	kWh	1,960
Nominal efficiency (cooling at 35°/27° nominal load, heating at 7°/20° nominal load)	EER		3.26	
	COP		3.41	
	Annual energy consumption		kWh	875
	Energy label	Cooling		A
		Heating		B

Notes

(1) EER/COP according to Eurovent 2012

2-5 Nominal Capacity And Nominal Input			FHQ60C/RXS60F	
Cooling capacity	Nom.	kW	5.7	
Heating capacity	Nom.	kW	7.2	
Seasonal efficiency (according to EN14825)	Cooling	Energy label		A
		Pdesign	kW	7.20
		SEER		5.54
		Annual energy consumption	kWh	360
	Heating (Average climate)	Energy label		A
		Pdesign	kW	5.07
		SCOP		3.50
		Annual energy consumption	kWh	2,026
Nominal efficiency (cooling at 35°/27° nominal load, heating at 7°/20° nominal load)	EER		3.26	
	COP		3.32	
	Annual energy consumption		kWh	875
	Energy label	Cooling		A
		Heating		C

Notes

(1) EER/COP according to Eurovent 2012

2 Specifications

2

2-6 Nominal Capacity And Nominal Input			FFQ60C/RXS60F	
Cooling capacity	Nom.	kW	5.70	
Heating capacity	Nom.	kW	7.00	
Seasonal efficiency (according to EN14825)	Cooling	Energy label	A+	
		Pdesign	kW	5.70
		SEER		5.60
		Annual energy consumption	kWh	356
	Heating (Average climate)	Energy label		A+
		Pdesign	kW	3.96
		SCOP		4.17
		Annual energy consumption	kWh	1,329
Nominal efficiency (cooling at 35°/27° nominal load, heating at 7°/20° nominal load)	EER		3.02	
	COP		3.41	
	Annual energy consumption		kWh	945
	Energy label	Cooling		B
		Heating		B

Notes

(1) EER/COP according to Eurovent 2012

2-7 Technical Specifications			RXS60F	RXS71F	
Capacity control	Method		Inverter controlled		
Casing	Colour		Ivory white		
Dimensions	Unit	Height	mm	735	770
		Width	mm	825	900
		Depth	mm	300	320
	Packed unit	Height	mm	797	900
		Width	mm	960	925
		Depth	mm	390	
Weight	Unit		kg	48	71
	Packed unit		kg	53	80
Heat exchanger	Length		mm	845	857
	Rows	Quantity		2	
	Fin pitch		mm	1.8	1.40
	Stages	Quantity		32	34
	Tube type			ø8 Hi-XA	ø8 Hi-XSS
	Fin	Type		Waffle louvered fin	
Compressor	Model		2YC36BXD#C	2YC36BXD#A	
	Type		Hermetically sealed swing compressor		

2 Specifications

2-7 Technical Specifications					RXS60F		RXS71F	
Fan	Type				Propeller fan			
	Air flow rate	Cooling	High	m ³ /min	50.9	54.5		
				cfm	1,797	1,924		
			Nom.	m ³ /min	50.9	54.5		
				cfm	1,797	1,924		
			Low	m ³ /min	42.4	57.1		
				cfm	1,496	1,624		
		Super low	m ³ /min	-	-			
			cfm	-	-			
		Heating	High	m ³ /min	46.3	52.5		
				cfm	1,635	1,854		
			Low	m ³ /min	42.4	46.0		
				cfm	1,496	1,624		
	Super low	m ³ /min	-	-				
		cfm	-	-				
	Running current	Cooling	Low	A	8.23	9.71		
				A	8.62	10.20		
				A	9.01	10.59		
		Heating	Low	A	8.41	10.44		
				A	8.80	10.93		
A				9.19	11.42			
Power consumption	Cooling	Low	W	1,950	2,305			
			W	1,950	2,305			
			W	1,950	2,305			
	Heating	Low	W	1,995	2,490			
			W	1,995	2,490			
			W	1,995	2,490			
Fan motor	Model				KFD-380-50-8C		KFD-280-66-8A	
	Output			W	53.00	66.00		
	Speed	Cooling	High	rpm	810	860		
				rpm	680	730		
			Super low	rpm	-	-		
		Heating	High	rpm	740	830		
rpm				680	730			
Super low			rpm	-	-			
Sound power level	Cooling	Nom.		dBA	63	65		
		Sound pressure level	High	dBA		49	52	
Low	dBA			46	49			
	Heating		High	dBA		49	52	
Low				dBA		46	49	
	Operation range	Cooling	Ambient	Min.	°CDB	-10		
Max.				°CDB	46			
Heating		Ambient	Min.	°CWB	-15			
			Max.	°CWB	20			
Refrigerant	Type				R-410A			
	Charge			kg	1.5	2.3		
	GWP				1,975			
Refrigerant oil	Type				FVC50K			
	Charged volume			l	0.65	0.75		
Piping connections	Drain	ID		mm	-			
	Piping length	OU - IU	Max.	m	30			
			Chargele ss	m	10			
Level difference	IU - OU	Max.	m	20				

2 Specifications

2-8 Electrical Specifications			RXS60F	RXS71F	
Power supply	Phase		1~		
	Frequency	Hz	50		
	Voltage		V		220-240
Current	Starting current	Cooling	A	9.4	11.7
		Heating	A	9.4	11.7
Current - 50Hz	Maximum fuse amps (MFA)		A	20	
Current - 60Hz	Maximum fuse amps (MFA)		A	-	
Wiring connections	For power supply	Quantity		3	
	For connection with indoor	Quantity		4	
		Remark		Earth wire included	

Notes

- (1) 220V
- (2) 230V
- (3) 240V
- (4) SL: The silent fan level of the air flow rate setting

3 Electrical data

3 - 1 Electrical Data

Representative unit combination		Power supply				Comp.		OFM		IFM	
Indoor unit	Outdoor unit	Hz-volts	Voltage range	MCA	MFA	RHz	RLA	W	FLA	W	FLA
FTXS71G	RXS71F	50 - 220 50 - 230 50 - 240	Max. 50Hz 264V Min. 50Hz 198V	19.75	20.0	57	10.3	66	0.40	43	0.19
							9.9				
							9.4				
FTXS60G	RXS60F	50 - 220 50 - 230 50 - 240	Max. 50Hz 264V Min. 50Hz 198V	19.75	20.0	84	8.7	53	0.32	43	0.16
							8.3				
							7.9				

3D056032D

SYMBOLS

- MCA : Min. Circuit Amps (A)
- MFA : Max. Fuse Amps (A)
- RLA : Rated Load Amps (A)
- OFM : Outdoor fan motor
- IFM : Indoor Fan Motor
- FLA : Full Load Amps (A)
- W : Fan Motor Rated Output (W)
- RHz : Rated operating frequency (Hz)

NOTES

1. RLA is based on the following conditions:
Indoor temp.: 27°CDB/19.0°CWB
Outdoor temp.: 35°CDB
2. Maximum allowable voltage variation between phases is 2%.
3. Select wire size based on the larger value of MCA.
4. Instead of fuse, use circuit breaker.

Minimum Ssc value: kVA
Equipment complying with EN61000-3-12

RXS60F

Unit combination		Power supply				Comp.	OFM		IFM	
Indoor unit	Outdoor unit	Hz-volts	Voltage range	MCA	MFA	RLA	kW	FLA	kW	FLA
FCQG60F	RXS60F	50 - 220 50 - 230 50 - 240	Max. 50Hz 253V Min. 50Hz 207V	19.75	20	7.4	0.053	0.19	0.048	0.30
						7.1				
						6.8				

3D077408B

SYMBOLS

- MCA : Min. Circuit Amps
- MFA : Max. Fuse Amps (See note 6)
- RLA : Rated Load Amps
- OFM : Outdoor fan motor
- IFM : Indoor Fan Motor
- FLA : Full Load Amps
- kW : Fan Motor Rated Output

NOTES

1. RLA is based on the following conditions:
Indoor temp.: 27°CDB/19.0°CWB
Outdoor temp.: 35°CDB
2. Voltage range
Units are suitable for use on electrical systems where the voltage supplied to the unit terminals is not below or above the listed range limits.
3. Maximum allowable voltage variation between phases is 2%.
4. MCA/MFA
MCA = 1.25 x RLA + all FLA, MFA = < 2.25 x RLA + all FLA (next lower standard fuse rating Min. 16A)
5. Select wire size based on the larger value of MCA.
6. Instead of fuse, use circuit breaker.

3 Electrical data

3 - 1 Electrical Data

3

RXS60F

Representative unit combination		Power supply				Comp.	OFM		IFM	
Indoor unit	Outdoor unit	Hz-volts	Voltage range	MCA	MFA	RLA	W	FLA	W	FLA
FHQ60C	RXS60F	50 - 220 50 - 230 50 - 240	Max. 50Hz 264V Min. 50Hz 198V	18	20	8.84	53	0.24	91	0.60

3D080360

SYMBOLS

MCA : Min. Circuit Amps (A)
MFA : Max. Fuse Amps (A)
RLA : Rated Load Amps (A)
OFM : Outdoor fan motor
IFM : Indoor Fan Motor
FLA : Full Load Amps (A)
W : Fan Motor Rated Output (W)

NOTES

1. RLA is based on the following conditions:
Indoor temp.: 27°CDB/19.0°CWB
Outdoor temp.: 35°CDB
2. Maximum allowable voltage variation between phases is 2%.
3. Select wire size based on the larger value of MCA.
4. Instead of fuse, use circuit breaker.

RXS60F

Representative unit combination		Power supply				COMP		OFM		IFM	
Indoor unit	Outdoor unit	Hz-volts	Voltage range	MCA	MFA	RHz	RLA	W	FLA	W	FLA
FDXS60F	RXS60F	50 - 220 50 - 230 50 - 240	Max. 50Hz 264V Min. 50Hz 198V	19,75	20	87	8,9	53	0,32	60	0,5

3D081371

SYMBOLS

MCA : Min. Circuit Amps. (A)
MFA : Max. Fuse Amps (A)
RHz : Rated operating frequency (Hz)
RLA : Rated Load Amps. (A)
OFM : Outdoor Fan Motor.
IFM : Indoor Fan Motor.
FLA : Full Load Amps. (A)
W : Fan Motor Rated Output (W)

NOTES

1. RLA is based on the following conditions:
Indoor temp.: 27°CDB/19°CWB
Outdoor temp.: 35°CDB
2. Maximum allowable voltage variation between phases is 2%.
3. Select wire size based on the larger value of MCA.
4. Instead of fuse, use circuit breaker.
5. Be sure to install an earth leak detector. (One that can handle higher harmonics.) (This unit uses an inverter, which means that it must be used an earth leak detector capable handling high harmonics in order to prevent malfunctioning of the earth leak detector.)

3 Electrical data

3 - 1 Electrical Data

RXS60F

Representative unit combination		Power supply				COMP	OFM		IFM	
Indoor unit	Outdoor unit	Hz-volts	Voltage range	MCA	MFA	RLA	W	FLA	W	FLA
FBQ60C8	RXS60F	50 - 220	Max. 50Hz 264V Min. 50Hz 198V	19.75	20	7.4	53	0.19	56	0.40
		50 - 230				7.1				
		50 - 240				6.8				

Minimum Ssc value kVA Equipment complying with EN61000-3-12

3D067823A

SYMBOLS

- MCA : Min. Circuit Amps (A)
- MFA : Max. Fuse Amps (A)
- RLA : Rated Load Amps (A)
- OFM : Outdoor fan motor
- IFM : Indoor Fan Motor
- FLA : Full Load Amps (A)
- W : Fan Motor Rated Output (W)

NOTES

- 1 RLA is based on the following conditions:
Indoor temp.: 27°CDB/19.0°CWB
Outdoor temp.: 35°CDB
- 2 Maximum allowable voltage variation between phases is 2%.
- 3 Select wire size based on the larger value of MCA.
- 4 Instead of fuse, use circuit breaker.

RXS60F

Unit combination		Power supply				Compressor	OFM		IFM	
Indoor unit	Outdoor unit	Hz-volts	Voltage range	MCA	MFA	RLA	kW	FLA	kW	FLA
FFQ60C	RXS60F	50 - 220	Max. 50Hz 264V Min. 50Hz 198V	19.75	20	8.0	0.053	0.32	0.050	0.6
		50 - 230				7.7				
		50 - 240				7.4				

3D082554

SYMBOLS

- MCA : Min. Circuit Amps
- MFA : Max. Fuse Amps (See note 6)
- RLA : Rated Load Amps
- OFM : Outdoor fan motor
- IFM : Indoor Fan Motor
- FLA : Full Load Amps
- kW : Fan Motor Rated Output

NOTES

1. RLA is based on the following conditions:
Indoor temp.: 27°CDB/19°CWB
Outdoor temp.: 35°CDB
2. Voltage range
Units are suitable for use on electrical systems where the voltage supplied to the unit terminals is not below or above the listed range limits.
3. Maximum allowable voltage variation between phases is 2%.
4. MCA/MFA
 $MCA = 1.25 \times RLA + \text{all FLA}$, $MFA = < 2.25 \times RLA + \text{all FLA}$ (next lower standard fuse rating Min. 16A)
5. Select wire size based on the larger value of MCA.
6. Instead of fuse, use circuit breaker.

4 Capacity tables

4 - 1 Cooling/Heating Capacity Tables

4

FDXS60F + RXS60F

Cooling 50Hz 220-240V

AFR	16.0
BF	0.12

Indoor		Outdoor temp. (°CDB)																	
EWB (°C)	EDB (°C)	20			25			30			32			35			40		
		TC	SHC	PI	TC	SHC	PI	TC	SHC	PI	TC	SHC	PI	TC	SHC	PI	TC	SHC	PI
14.0	20	6.12	4.31	1.63	5.87	4.18	1.79	5.59	4.03	1.95	5.48	3.97	2.01	5.31	3.89	2.11	5.03	3.74	2.26
16.0	22	6.42	4.25	1.64	6.14	4.11	1.80	5.86	3.97	1.96	5.75	3.92	2.02	5.59	3.84	2.12	5.31	3.70	2.27
18.0	25	6.70	4.41	1.65	6.42	4.28	1.81	6.14	4.15	1.97	6.03	4.10	2.03	5.86	4.02	2.13	5.58	3.90	2.28
19.0	27	6.84	4.61	1.66	6.56	4.49	1.82	6.28	4.36	1.97	6.17	4.31	2.04	6.00	4.24	2.13	5.72	4.12	2.29
22.0	30	7.25	4.43	1.67	6.97	4.32	1.83	6.69	4.21	1.99	6.58	4.17	2.05	6.41	4.10	2.14	6.14	4.00	2.30
24.0	32	7.53	4.30	1.68	7.25	4.20	1.84	6.97	4.10	2.00	6.86	4.06	2.06	6.69	4.00	2.15	6.41	3.91	2.31

Heating 50Hz 220-240V

AFR	16.0
-----	------

Indoor EDB (°C)	Outdoor temp. (°CWB)									
	-10		-5		0		6		10	
	TC	PI	TC	PI	TC	PI	TC	PI	TC	PI
15.0	4.71	1.96	5.50	2.06	6.29	2.15	7.24	2.27	7.87	2.34
20.0	4.47	2.01	5.26	2.11	6.05	2.21	7.00	2.32	7.63	2.40
22.0	4.37	2.04	5.16	2.13	5.95	2.23	6.90	2.34	7.54	2.42
24.0	4.28	2.06	5.07	2.15	5.86	2.25	6.81	2.36	7.44	2.44
25.0	4.23	2.07	5.02	2.16	5.81	2.26	6.76	2.37	7.39	2.45
27.0	4.13	2.09	4.92	2.18	5.71	2.28	6.66	2.39	7.29	2.47

3D081326

SYMBOLS

AFR:	Air flow rate	(m ³ /min)
BF:	Bypass factor	
EWB:	Entering wet bulb temp.	(°C)
EDB:	Entering dry bulb temp.	(°C)
TC:	Total capacity	(kW)
SHC:	Sensible heat capacity	(kW)
PI:	Power input	(kW)

NOTES

1. Ratings shown are net capacities which include a deduction for indoor fan motor heat.
2. shows nominal (rated) capacities and power input.
3. TC, PI and SHC must be calculated by interpolation using the figures in the above tables. (Figures out of the tables should not be used for calculation.)
4. About SHC which are not mentioned on the table, please calculate them with around values in direct proportion.
5. Capacities are based on the following conditions:
Corresponding refrigerant piping length: 7.5m
Level difference: 0m
6. Air flow rate (AFR) and Bypass factor (BF) are tabulated above table.

4 Capacity tables

4 - 1 Cooling/Heating Capacity Tables

FCQG60F + RXS60F

Cooling 220-240V 50Hz

AFR	13.6
BF	0.20

Indoor		Outdoor temperature (°CDB)																	
EWB °C	EDB °C	20			25			30			32			35			40		
		TC	SHC	PI	TC	SHC	PI	TC	SHC	PI	TC	SHC	PI	TC	SHC	PI	TC	SHC	PI
14,0	20	5,84	4,01	1,26	5,57	3,86	1,38	5,31	3,72	1,50	5,20	3,66	1,55	5,04	3,58	1,62	4,78	3,44	1,74
16,0	22	6,10	3,94	1,27	5,84	3,80	1,39	5,57	3,67	1,51	5,47	3,61	1,56	5,31	3,53	1,63	5,04	3,40	1,75
18,0	25	6,36	4,07	1,27	6,10	3,94	1,39	5,83	3,81	1,52	5,73	3,76	1,56	5,57	3,69	1,64	5,30	3,56	1,76
19,0	27	6,50	4,24	1,28	6,23	4,11	1,40	5,97	3,99	1,52	5,86	3,94	1,57	5,70	3,87	1,64	5,43	3,75	1,76
22,0	30	6,89	4,07	1,29	6,62	3,95	1,41	6,36	3,85	1,53	6,25	3,80	1,58	6,09	3,74	1,65	5,83	3,63	1,77
24,0	32	7,15	3,94	1,29	6,89	3,84	1,42	6,62	3,74	1,54	6,52	3,70	1,59	6,36	3,64	1,66	6,09	3,54	1,78

Heating 220-240V 50Hz

AFR	13.6
-----	------

Indoor		Outdoor temperature (°CWB)									
EDB °C	°C	-10		-5		0		6		10	
		TC	PI	TC	PI	TC	PI	TC	PI	TC	PI
15,0		4,71	1,68	5,50	1,76	6,29	1,85	7,24	1,95	7,87	2,01
20,0		4,47	1,73	5,26	1,81	6,05	1,89	7,00	1,99	7,63	2,06
22,0		4,37	1,75	5,16	1,83	5,95	1,91	6,90	2,01	7,54	2,07
24,0		4,28	1,76	5,07	1,85	5,86	1,93	6,81	2,03	7,12	2,09
25,0		4,23	1,77	5,02	1,85	5,81	1,94	6,76	2,03	6,90	2,10
27,0		4,13	1,79	4,92	1,87	5,71	1,95	6,45	2,05	6,45	2,11

3D077501A

SYMBOLS

AFR:	Air flow rate	(m ³ /Min.)
BF:	Bypass factor	
EWB:	Entering wet bulb temp.	(°C)
EDB:	Entering dry bulb temp.	(°C)
TC:	Total capacity	(kW)
SHC:	Sensible heat capacity	(kW)
PI:	Power input	(kW)

NOTES

1. shows nominal (rated) capacities and power input.
2. Capacities are based on the following conditions:
 - (1) Corresponding refrigerant piping length: 5m
 - (2) Level difference: 0m

4 Capacity tables

4 - 1 Cooling/Heating Capacity Tables

FBQ60C8+RXS60F

Cooling

50Hz 220 - 240V

AFR	18
BF	0.15

Indoor		Outdoor temperature (°CDB)																	
EWB °C	EDB °C	20			25			30			32			35			40		
		TC	SHC	PI	TC	SHC	PI	TC	SHC	PI	TC	SHC	PI	TC	SHC	PI	TC	SHC	PI
14.0	20	5.84	4.42	1.34	5.57	4.29	1.47	5.31	4.16	1.60	5.20	4.11	1.65	5.04	4.03	1.73	4.78	3.90	1.86
16.0	22	6.10	4.34	1.35	5.84	4.22	1.48	5.57	4.10	1.61	5.47	4.05	1.66	5.31	3.98	1.74	5.04	3.86	1.87
18.0	25	6.36	4.56	1.36	6.10	4.45	1.49	5.83	4.33	1.62	5.73	4.29	1.67	5.57	4.22	1.74	5.30	4.11	1.87
19.0	27	6.50	4.82	1.36	6.23	4.71	1.49	5.97	4.60	1.62	5.86	4.56	1.67	5.70	4.50	1.75	5.43	4.39	1.88
22.0	30	6.89	4.66	1.37	6.62	4.56	1.50	6.36	4.46	1.63	6.25	4.42	1.68	6.09	4.37	1.76	5.83	4.27	1.89
24.0	32	7.15	4.54	1.38	6.89	4.45	1.51	6.62	4.36	1.64	6.52	4.33	1.69	6.36	4.27	1.77	6.09	4.19	1.90

Heating

50Hz 220 - 240V

AFR	18
-----	----

Indoor		Outdoor temperature (°CWB)									
EDB °C	TC	-10		-5		0		6		10	
		PI	TC	PI	TC	PI	TC	PI	TC	PI	
15.0	4.71	1.74	5.50	1.82	6.29	1.91	7.24	2.01	7.87	2.07	
20.0	4.47	1.78	5.26	1.87	6.05	1.95	7.00	2.05	7.63	2.12	
22.0	4.37	1.80	5.16	1.89	5.95	1.97	6.90	2.07	7.54	2.14	
24.0	4.28	1.82	5.07	1.90	5.86	1.99	6.81	2.09	7.44	2.16	
25.0	4.23	1.83	5.02	1.91	5.81	2.00	6.76	2.10	7.39	2.17	
27.0	4.13	1.85	4.92	1.93	5.71	2.02	6.66	2.12	7.29	2.19	

3TW31292-3B

SYMBOLS

AFR:	Air flow rate	(m ³ /min.)
BF:	Bypass factor	
EWB:	Entering wet bulb temp.	(°C)
EDB:	Entering dry bulb temp.	(°C)
TC:	Total capacity	(kW)
SHC:	Sensible heat capacity	(kW)
PI:	Power input	(kW)

NOTES

- Capacities are based on the following conditions:
 - Corresponding refrigerant piping length: 5m
 - Level difference: 0m
-  shows nominal (rated) capacities and power input.

4 Capacity tables

4 - 1 Cooling/Heating Capacity Tables

FHQ60C + RXS60F

Cooling 220-240V 50Hz

AFR	19.5
BF	0.2

Indoor		Outdoor temperature (°CDB)																	
EWB °C	EDB °C	20			25			30			32			35			40		
		TC	SHC	PI	TC	SHC	PI	TC	SHC	PI	TC	SHC	PI	TC	SHC	PI	TC	SHC	PI
14.0	20	5.84	4.25	1.34	5.57	4.12	1.47	5.31	3.98	1.60	5.20	3.93	1.65	5.04	3.85	1.73	4.78	3.72	1.86
16.0	22	6.10	4.18	1.35	5.84	4.05	1.48	5.57	3.93	1.61	5.47	3.88	1.66	5.31	3.80	1.74	5.04	3.68	1.86
18.0	25	6.36	4.36	1.36	6.10	4.25	1.49	5.83	4.13	1.62	5.73	4.08	1.67	5.57	4.01	1.75	5.30	3.90	1.87
19.0	27	6.50	4.59	1.36	6.23	4.48	1.49	5.97	4.36	1.62	5.86	4.32	1.67	5.70	4.25	1.75	5.43	4.14	1.88
22.0	30	6.89	4.42	1.38	6.62	4.32	1.51	6.36	4.22	1.64	6.25	4.18	1.68	6.09	4.12	1.76	5.83	4.03	1.89
24.0	32	7.15	4.30	1.38	6.89	4.21	1.51	6.62	4.12	1.64	6.52	4.08	1.69	6.36	4.03	1.77	6.09	3.94	1.90

Heating 220-240V 50Hz

AFR	19.5
-----	------

Indoor		Outdoor temperature (°CDB)											
EDB °C		-15		-10		-5		0		6		10	
		TC	PI	TC	PI	TC	PI	TC	PI	TC	PI	TC	PI
15.0		4.03	1.74	4.85	1.84	5.66	1.93	6.47	2.01	7.45	2.12	8.10	2.20
20.0		3.79	1.80	4.60	1.88	5.41	1.97	6.22	2.07	7.20	2.17	7.85	2.24
22.0		3.69	1.81	4.50	1.90	5.31	2.00	6.12	2.08	7.10	2.19	7.75	2.26
24.0		3.59	1.83	4.40	1.93	5.21	2.01	6.03	2.10	7.00	2.20	7.51	2.28
25.0		3.54	1.85	4.35	1.93	5.16	2.02	5.98	2.11	6.95	2.22	7.28	2.29
27.0		3.44	1.86	4.25	1.95	5.06	2.04	5.88	2.14	6.81	2.24	6.81	2.31

3D080356

SYMBOLS

AFR:	Air flow rate	(m ³ /Min.)
BF:	Bypass factor	
EWB:	Entering wet bulb temp.	(°C)
EDB:	Entering dry bulb temp.	(°C)
TC:	Total capacity	(kW)
SHC:	Sensible heat capacity	(kW)
PI:	Power input	(kW)

NOTES

- Capacities are based on the following conditions:
 - Corresponding refrigerant piping length: 5m
 - Level difference: 0m
- | |
|--|
| |
|--|

 shows nominal (rated) capacities and power input.

4 Capacity tables

4 - 1 Cooling/Heating Capacity Tables

4

FFQ60C + RXS60F

Cooling 50Hz 220-240V

AFR	14.5
BF	0.11

Indoor		Outdoor temp. (°CDB)																	
EWB (°C)	EDB (°C)	20			25			30			32			35			40		
		TC	SHC	PI	TC	SHC	PI	TC	SHC	PI	TC	SHC	PI	TC	SHC	PI	TC	SHC	PI
14.0	20	5.76	4.23	1.57	5.61	4.16	1.66	5.46	4.09	1.74	5.41	4.06	1.78	5.32	4.02	1.84	5.17	3.95	1.92
16.0	22	5.92	4.27	1.60	5.77	4.20	1.68	5.62	4.13	1.77	5.56	4.10	1.80	5.47	4.06	1.85	5.33	3.99	1.94
18.0	25	6.06	4.29	1.62	5.92	4.23	1.71	5.77	4.16	1.79	5.71	4.13	1.83	5.62	4.09	1.88	5.47	4.02	1.96
19.0	27	6.14	4.31	1.63	5.99	4.25	1.72	5.85	4.18	1.81	5.79	4.15	1.84	5.70	4.11	1.89	5.55	4.04	1.98
22.0	30	6.37	4.36	1.66	6.22	4.29	1.75	6.07	4.23	1.84	6.01	4.20	1.87	5.93	4.16	1.93	5.78	4.09	2.01
24.0	32	6.53	4.39	1.69	6.38	4.32	1.78	6.23	4.26	1.86	6.17	4.23	1.90	6.08	4.19	1.95	5.94	4.12	2.04

Heating 50Hz 220-240V

AFR	14.5
-----	------

Indoor		Outdoor temp. (°CWB)											
EDB (°C)	TC	-15		-10		-5		0		6		10	
		TC	PI	TC	PI	TC	PI	TC	PI	TC	PI	TC	PI
16.0	3.51	1.47	4.36	1.57	5.21	1.68	6.05	1.78	7.07	1.90	7.75	1.98	
18.0	3.48	1.55	4.32	1.65	5.17	1.75	6.02	1.85	7.04	1.98	7.71	2.06	
20.0	3.44	1.62	4.29	1.72	5.14	1.83	5.98	1.93	7.00	2.05	7.68	2.13	
21.0	3.43	1.65	4.27	1.76	5.12	1.86	5.97	1.97	6.98	2.08	7.66	2.17	
22.0	3.41	1.70	4.25	1.79	5.10	1.90	5.95	2.00	6.97	2.12	7.64	2.21	
24.0	3.37	1.77	4.22	1.87	5.07	1.98	5.91	2.07	6.93	2.20	7.61	2.28	

3D082545

SYMBOLS

AFR:	Air flow rate	(m ³ /min)
BF:	Bypass factor	
EWB:	Entering wet bulb temp.	(°C)
EDB:	Entering dry bulb temp.	(°C)
TC:	Total capacity	(kW)
SHC:	Sensible heat capacity	(kW)
PI:	Power input	(kW)

NOTES

- shows nominal (rated) capacities and power input.
- Capacities are based on the following conditions:
Corresponding refrigerant piping length: 5.0m
Level difference: 0m

4 Capacity tables

4 - 1 Cooling/Heating Capacity Tables

FTXS60G + RXS60F

Cooling 50Hz 220-240V

AFR	16.0
BF	0.29

Indoor		Outdoor temperature (°CDB)																	
EWB °C	EDB °C	20			25			30			32			35			40		
		TC	SHC	PI	TC	SHC	PI	TC	SHC	PI	TC	SHC	PI	TC	SHC	PI	TC	SHC	PI
14.0	20	5.53	3.90	1.49	5.53	3.90	1.66	5.53	3.90	1.82	5.48	3.87	1.88	5.31	3.78	1.97	5.03	3.63	2.12
16.0	22	6.42	4.16	1.54	6.14	4.01	1.68	5.86	3.87	1.83	5.75	3.81	1.89	5.59	3.73	1.98	5.31	3.59	2.12
18.0	25	6.70	4.29	1.54	6.42	4.16	1.69	6.14	4.03	1.84	6.03	3.97	1.90	5.86	3.89	1.99	5.58	3.77	2.13
19.0	27	6.84	4.47	1.55	6.56	4.34	1.70	6.28	4.21	1.84	6.17	4.16	1.90	6.00	4.09	1.99	5.72	3.96	2.14
22.0	30	7.25	4.29	1.58	6.97	4.18	1.71	6.69	4.06	1.86	6.58	4.02	1.91	6.41	3.95	2.00	6.14	3.84	2.15
24.0	32	7.53	4.16	1.57	7.25	4.06	1.72	6.97	3.95	1.86	6.86	3.91	1.92	6.69	3.85	2.01	6.41	3.75	2.16

Heating 50Hz 220-240V

AFR	17.2
-----	------

Indoor		Outdoor temperature (°CWB)									
EDB °C		-10		-5		0		6		10	
		TC	PI	TC	PI	TC	PI	TC	PI	TC	PI
15.0		4.71	1.73	5.50	1.81	6.29	1.89	7.24	1.99	7.87	2.06
20.0		4.47	1.77	5.26	1.86	6.05	1.94	7.00	2.04	7.63	2.11
22.0		4.37	1.79	5.16	1.87	5.95	1.96	6.90	2.06	7.54	2.13
24.0		4.28	1.81	5.07	1.89	5.86	1.98	6.81	2.08	7.44	2.14
25.0		4.23	1.82	5.02	1.90	5.81	1.99	6.76	2.09	7.39	2.15
27.0		4.13	1.84	4.92	1.92	5.71	2.00	6.66	2.10	7.29	2.17

3D0663188

SYMBOLS

AFR:	Air flow rate	(m ³ /Min.)
BF:	Bypass factor	
EWB:	Entering wet bulb temp.	(°C)
EDB:	Entering dry bulb temp.	(°C)
TC:	Total capacity	(kW)
SHC:	Sensible heat capacity	(kW)
PI:	Power input	(kW)

NOTES

- Ratings shown are net capacities which include a deduction for indoor fan motor heat.
- shows nominal (rated) capacities and power input.
- TC, PI and SHC must be calculated by interpolation using the figures in the above tables. (Figures out of the tables should not be used for calculation.)
- About SHC which are not mentioned on the table, please calculate them with around values in direct proportion.
- Capacities are based on the following conditions:
 - Corresponding refrigerant piping length: 5m
 - Level difference: 0m
- Air flow rate (AFR) and Bypass factor (BF) are tabulated above table.

4 Capacity tables

4 - 1 Cooling/Heating Capacity Tables

FTXS71G + RXS71F

Cooling 50Hz 220-240V

AFR	17.2
BF	0.17

Indoor		Outdoor temperature (°CDB)																	
EWB °C	EDB °C	20			25			30			32			35			40		
		TC	SHC	PI	TC	SHC	PI	TC	SHC	PI	TC	SHC	PI	TC	SHC	PI	TC	SHC	PI
14.0	20	6.95	4.90	1.77	6.94	4.89	1.98	6.61	4.72	2.15	6.48	4.65	2.22	6.28	4.54	2.32	5.95	4.37	2.50
16.0	22	7.60	4.98	1.81	7.27	4.81	1.99	6.94	4.65	2.16	6.81	4.58	2.23	6.61	4.48	2.33	6.28	4.32	2.51
18.0	25	7.93	5.16	1.82	7.60	5.00	2.00	7.27	4.85	2.17	7.13	4.79	2.24	6.94	4.70	2.34	6.61	4.55	2.52
19.0	27	8.09	5.39	1.83	7.76	5.24	2.00	7.43	5.09	2.18	7.30	5.03	2.25	7.10	4.94	2.35	6.77	4.80	2.52
22.0	30	8.58	5.18	1.84	8.25	5.04	2.02	7.92	4.91	2.19	7.79	4.86	2.26	7.59	4.78	2.37	7.26	4.65	2.54
24.0	32	8.91	5.02	1.85	8.58	4.90	2.03	8.25	4.78	2.20	8.12	4.73	2.27	7.92	4.66	2.38	7.59	4.54	2.55

Heating 50Hz 220-240V

AFR	19.5
-----	------

Indoor		Outdoor temperature (°CWB)									
EDB °C		-10		-5		0		6		10	
		TC	PI	TC	PI	TC	PI	TC	PI	TC	PI
15.0		5.52	2.16	6.45	2.26	7.37	2.37	8.48	2.49	9.22	2.58
20.0		5.24	2.21	6.16	2.32	7.09	2.42	8.20	2.55	8.94	2.63
22.0		5.12	2.24	6.05	2.34	6.98	2.45	8.09	2.57	8.83	2.66
24.0		5.01	2.26	5.94	2.36	6.86	2.47	7.97	2.60	8.65	2.68
25.0		4.95	2.27	5.88	2.38	6.81	2.48	7.92	2.61	8.38	2.67
27.0		4.84	2.29	5.77	2.40	6.69	2.50	7.80	2.63	7.84	2.67

3D066316B

SYMBOLS

AFR:	Air flow rate	(m ³ /Min.)
BF:	Bypass factor	
EWB:	Entering wet bulb temp.	(°C)
EDB:	Entering dry bulb temp.	(°C)
TC:	Total capacity	(kW)
SHC:	Sensible heat capacity	(kW)
PI:	Power input	(kW)

NOTES

1. Ratings shown are net capacities which include a deduction for indoor fan motor heat.
2. shows nominal (rated) capacities and power input.
3. TC, PI and SHC must be calculated by interpolation using the figures in the above tables. (Figures out of the tables should not be used for calculation.)
4. About SHC which are not mentioned on the table, please calculate them with around values in direct proportion.
5. Capacities are based on the following conditions:
 - (1) Corresponding refrigerant piping length: 5m
 - (2) Level difference: 0m
6. Air flow rate (AFR) and Bypass factor (BF) are tabulated above table.

5 Dimensional drawings

5 - 1 Dimensional Drawings

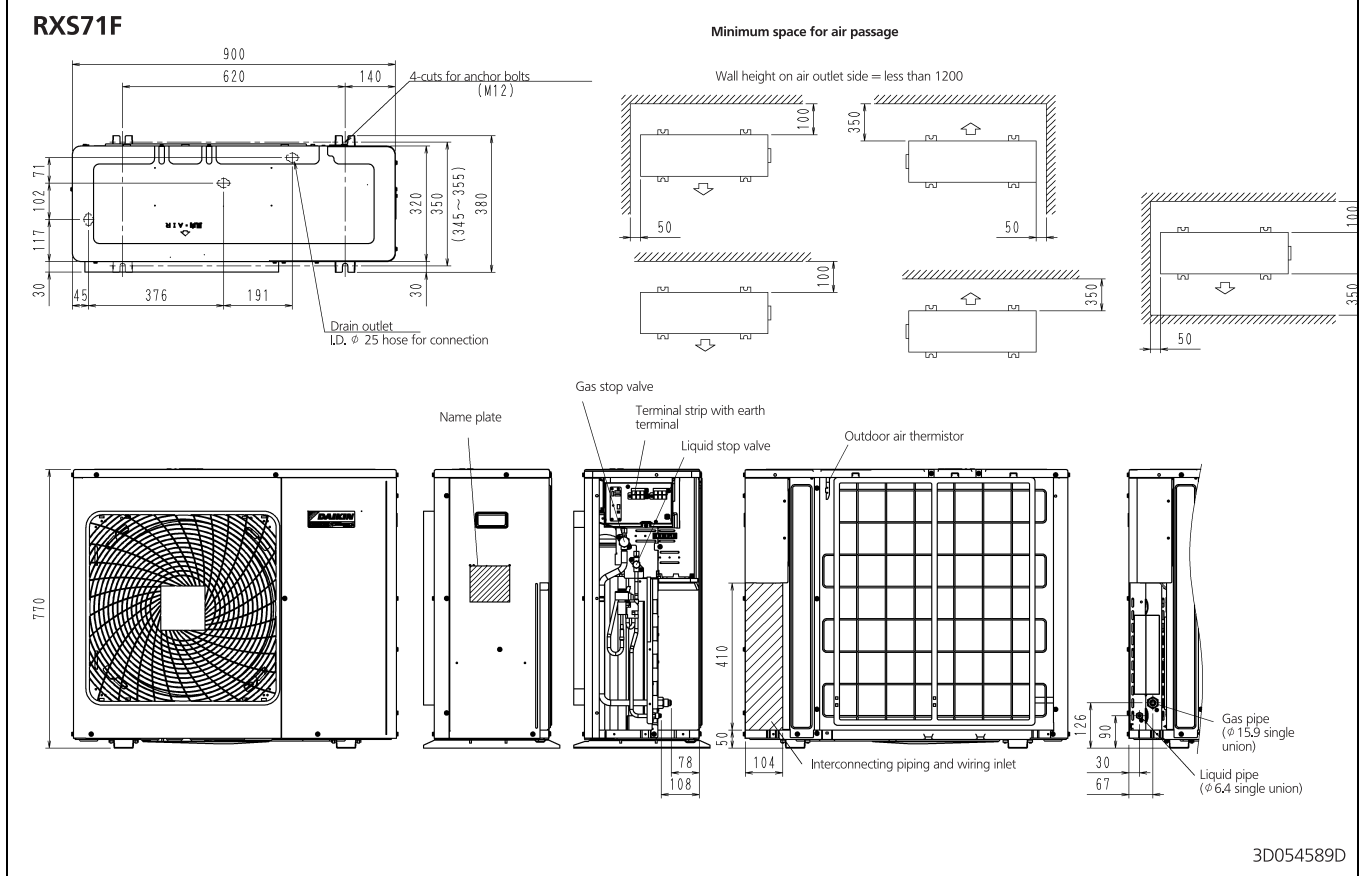
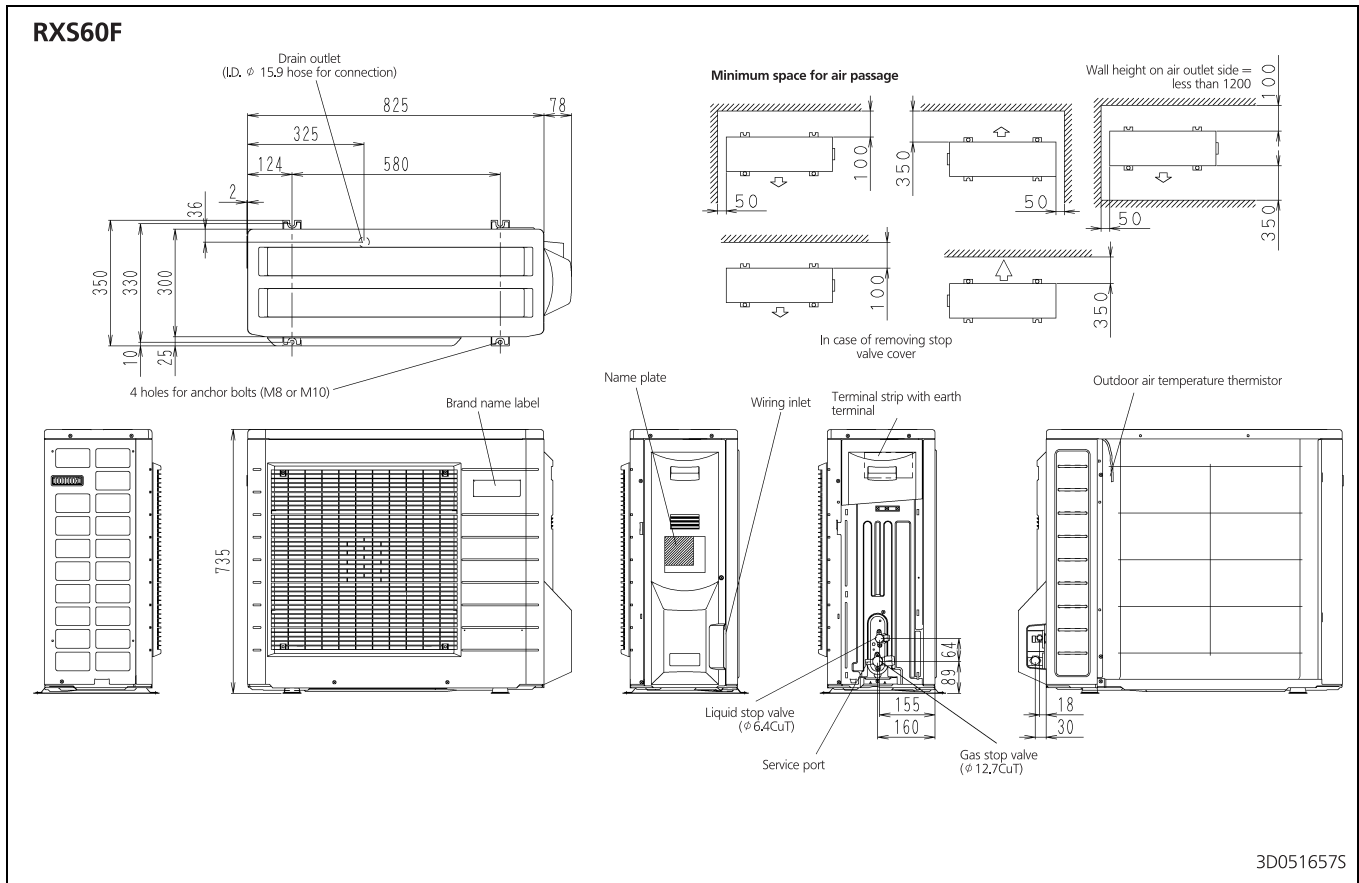

6 Centre of gravity

6 - 1 Centre of Gravity

6

RXS60F

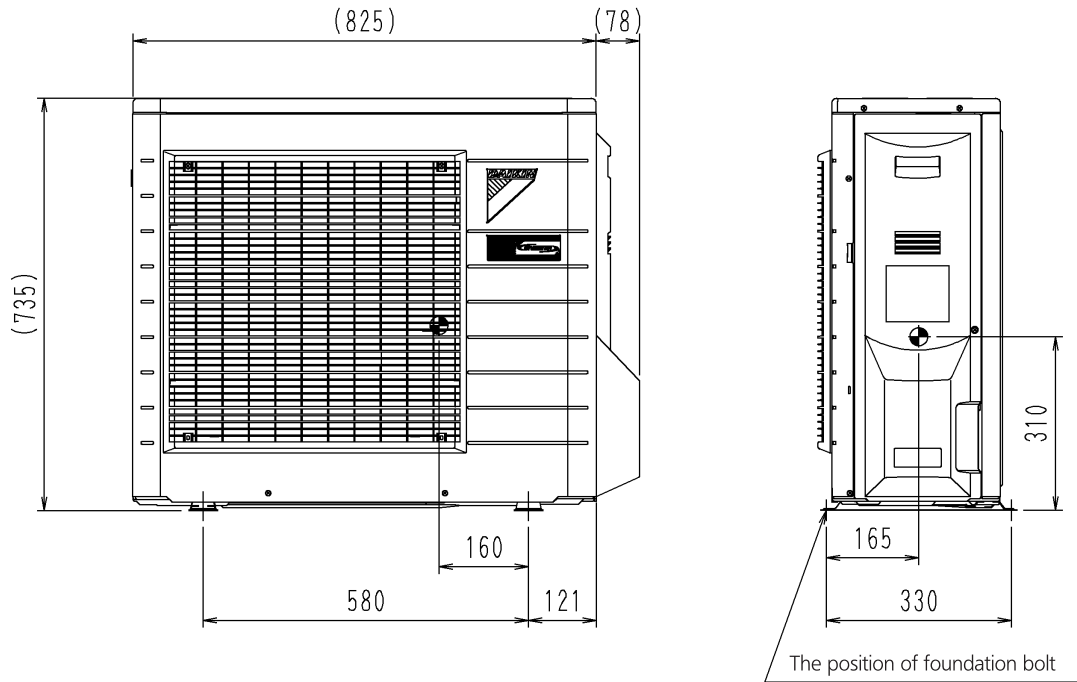

4D080604

RXS71F

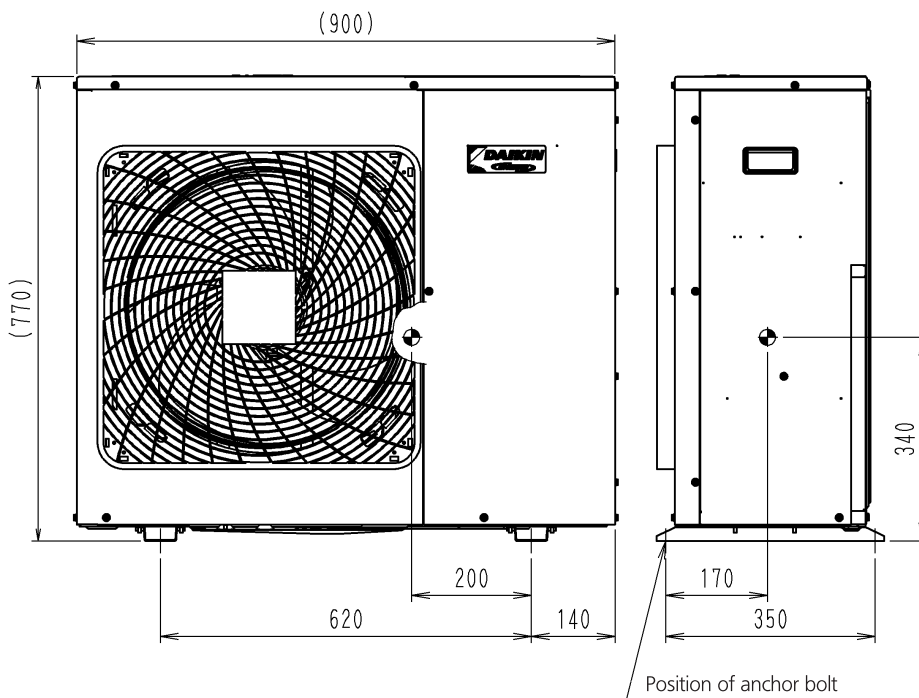

4D053630E

7 Piping diagrams

7 - 1 Piping Diagrams

RXS60F

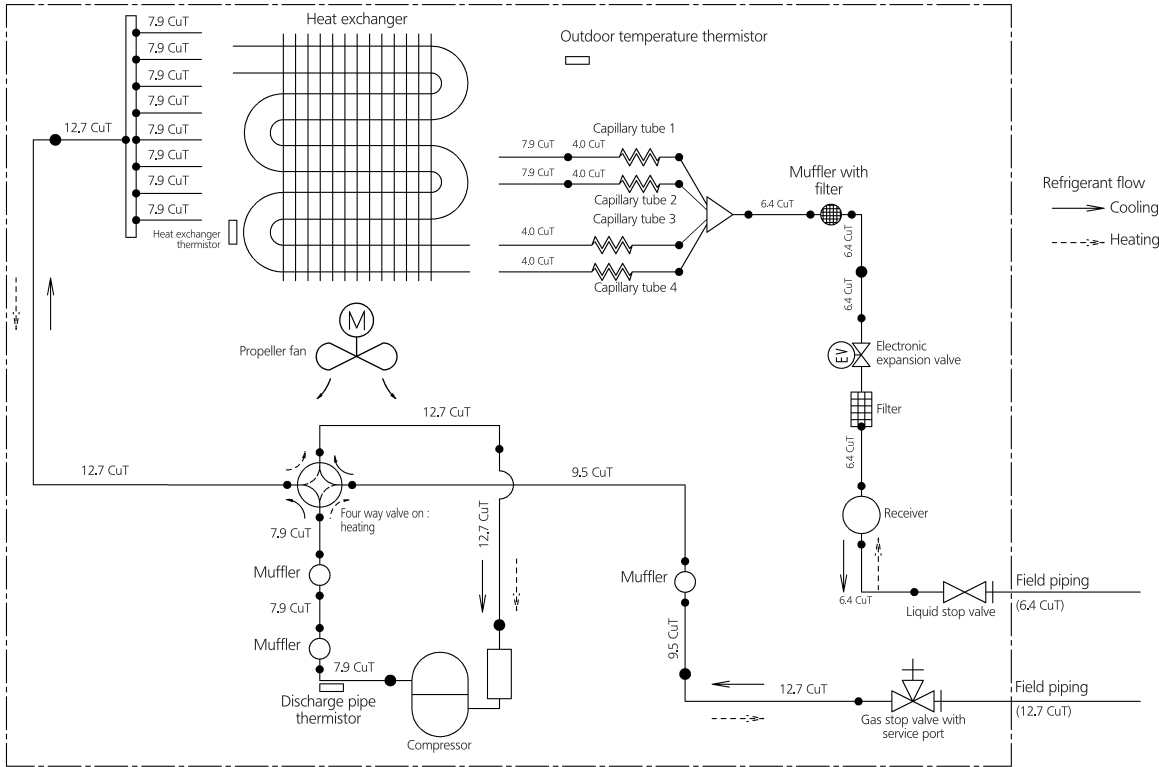

3D080605

RXS71F

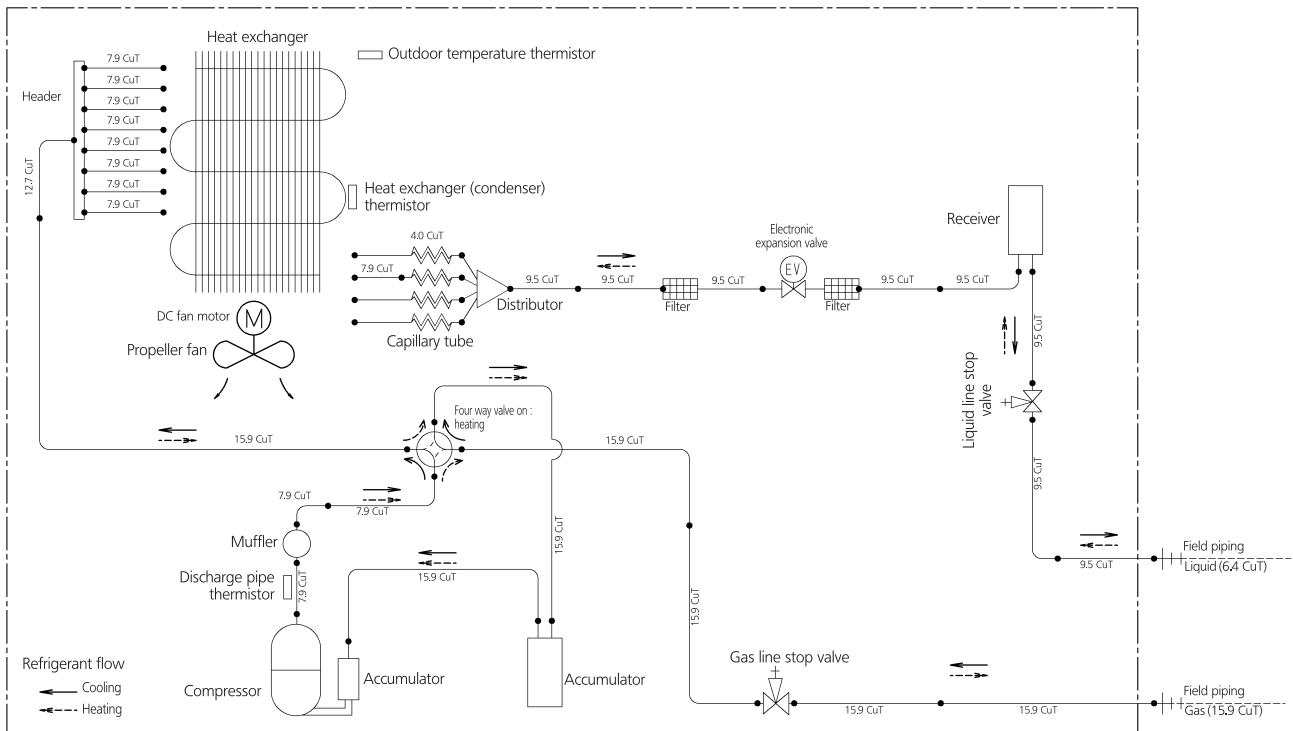

3D054593L

8 Wiring diagrams

8 - 1 Wiring Diagrams - Single Phase

8

RXS60F

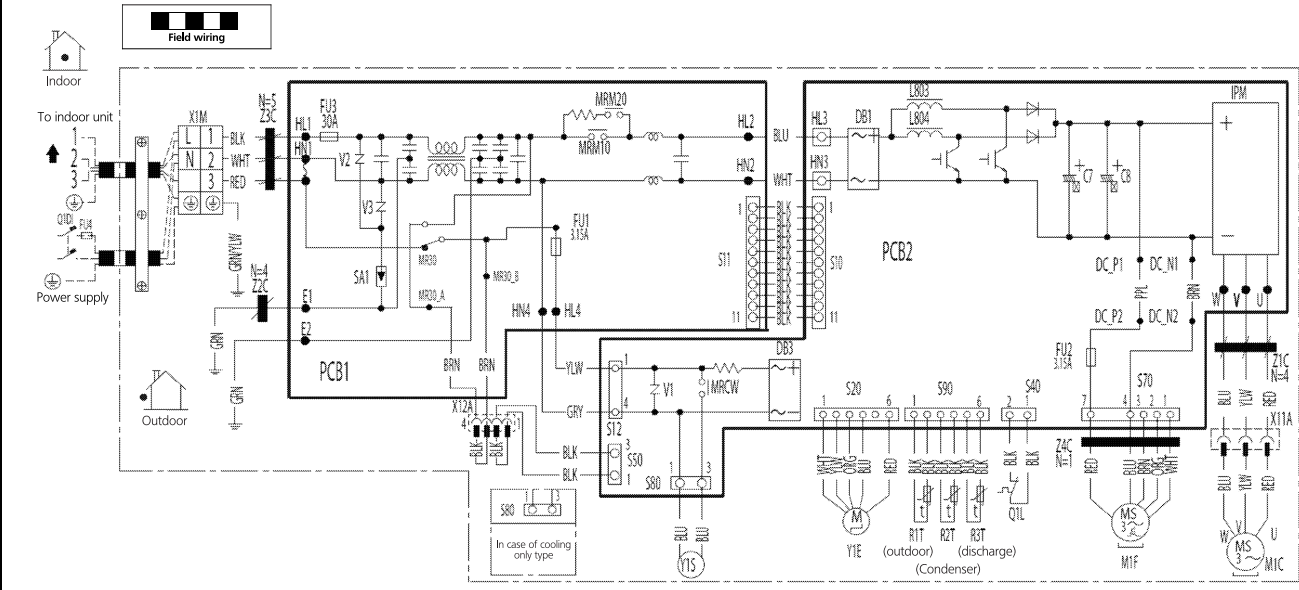

- Notes
 1. Refer to purchasing specification AS303002, unless otherwise specified.
 2. Size: length 140 x width 230.
 3. Refer to the nameplate for the power requirements.
- | | | | | | |
|---------------|----------------------------|---------------------|-------------------------|-----------------|-----------------------------------|
| C7,C8 | : Capacitor | N | : Neutral | V1,V2,V3 | : Varistor |
| DB1,DB3 | : Diode bridge | Q1L | : Overload protector | X1M | : Terminal strip |
| FU1,FU2,FU3 | : Fuse | Q1DI | : Earth leak detector | Y1E | : Electronic expansion valve coil |
| FU4 | : Field fuse | PCB1,PCB2 | : Printed circuit board | Y1S | : Reversing solenoid valve coil |
| IPM | : Intelligent power module | S40,S50,S70,S80,S90 | : Connector | Z1C,Z2C,Z3C,Z4C | : Ferrite core |
| L | : Live | HL3,HN3,X11A,X12A | : Connector | ⊕ | : Protective earth |
| L803,L804 | : Reactor | R1T,R2T,R3T | : Thermistor | ⊖ | : Earth |
| M1C | : Compressor motor | SA1 | : Surge absorber | | |
| M1F | : Fan motor | | | | |
| MRCW,MRM10 | | | | | |
| MRM20,MR30 | | | | | |
| MR30_A,MR30_B | : Magnetic relay | | | | |

3D079016

RXS71F

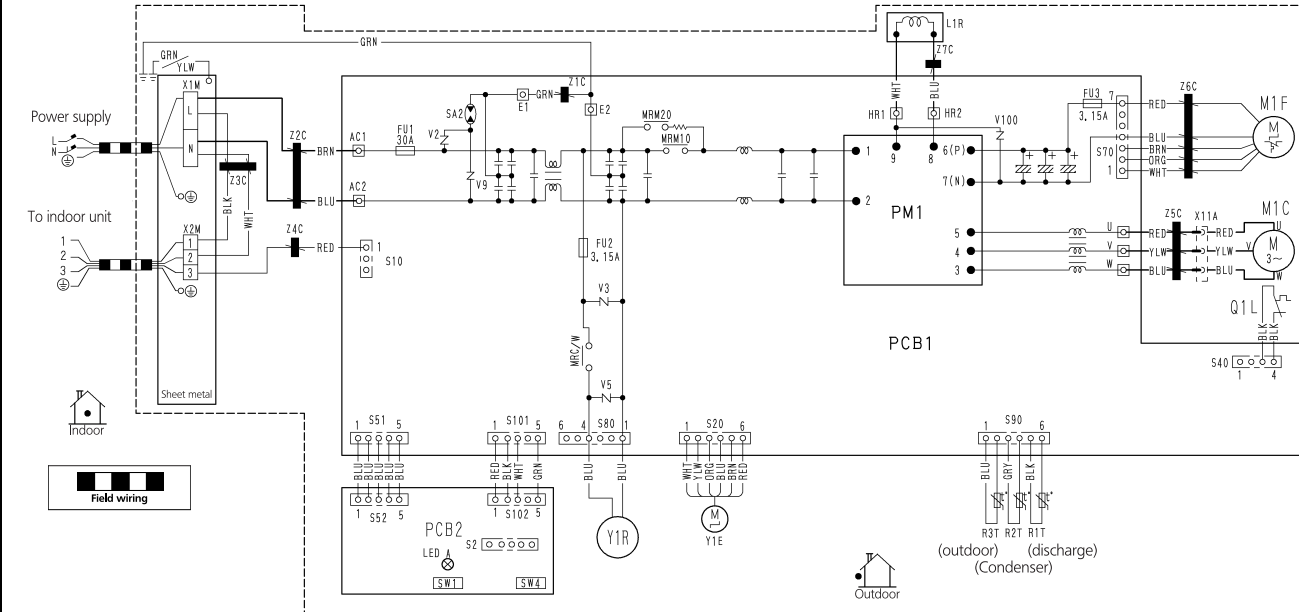

- Notes
 1. Refer to purchasing specification AS303002, unless otherwise specified.
 2. This drawing was drawn on CAD system.
 3. After printing, attach the coating film on the printed side.
- | | | | | | |
|--------------------|-----------------------------------|---------|---|-------------|---------------------------------|
| Z1C-Z7C | : Ferrite core | R1T-R3T | : Thermistor | M1C | : Compressor motor |
| X1M,X2M | : Terminal strip | S2-S102 | : Connector | M1F | : Fan motor |
| Y1E | : Electronic expansion valve coil | LEDA | : Pilot lamp | L1R | : Reactor |
| V2,V3,V5,V9,V100 | : Varistor | L | : Live | Q1L | : Overload protector |
| SA2 | : Surge arrester | N | : Neutral | PM1 | : Power module |
| FU1,FU2,FU3 | : Fuse | SW1 | : Neutral operation on/off switch (SW1) | PCB1, 2 | : Printed circuit board |
| AC1,AC2 | | SW4 | : Local setting SW (SW4) | Y1R | : Reversing solenoid valve coil |
| U,V,W,X11A,X12A | | | | Sheet metal | : Terminal strip fixed plate |
| E1,E2 | | | | | |
| HR1,HR2 | : Connector | | | | |
| MRM10, MRM20, MRCW | : Magnetic relay | | | | |

3D053931L

9 Sound data

9 - 1 Sound Pressure Spectrum - Cooling

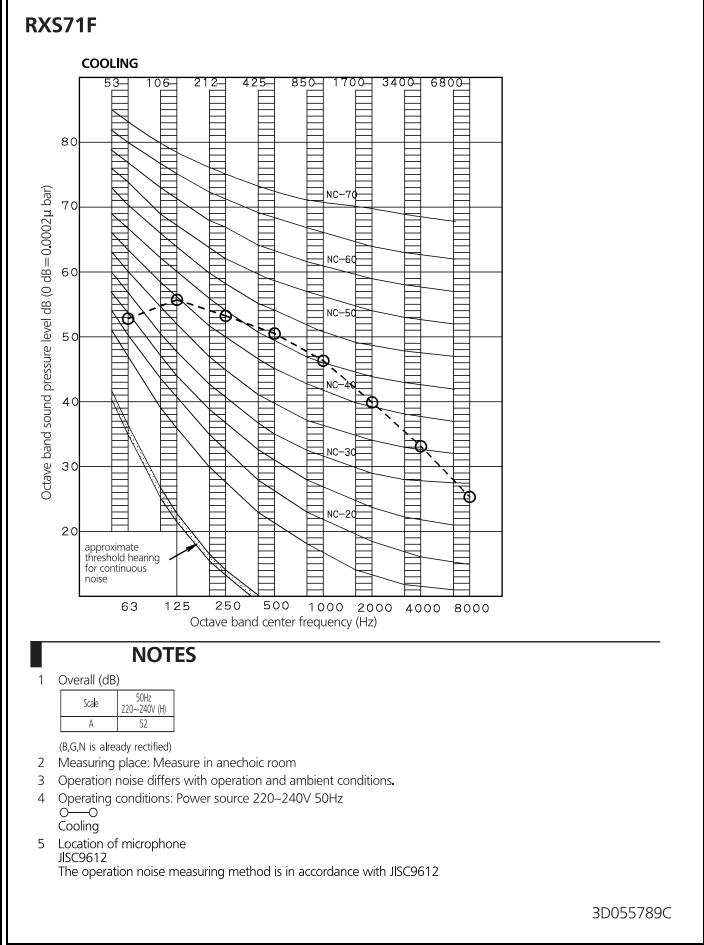
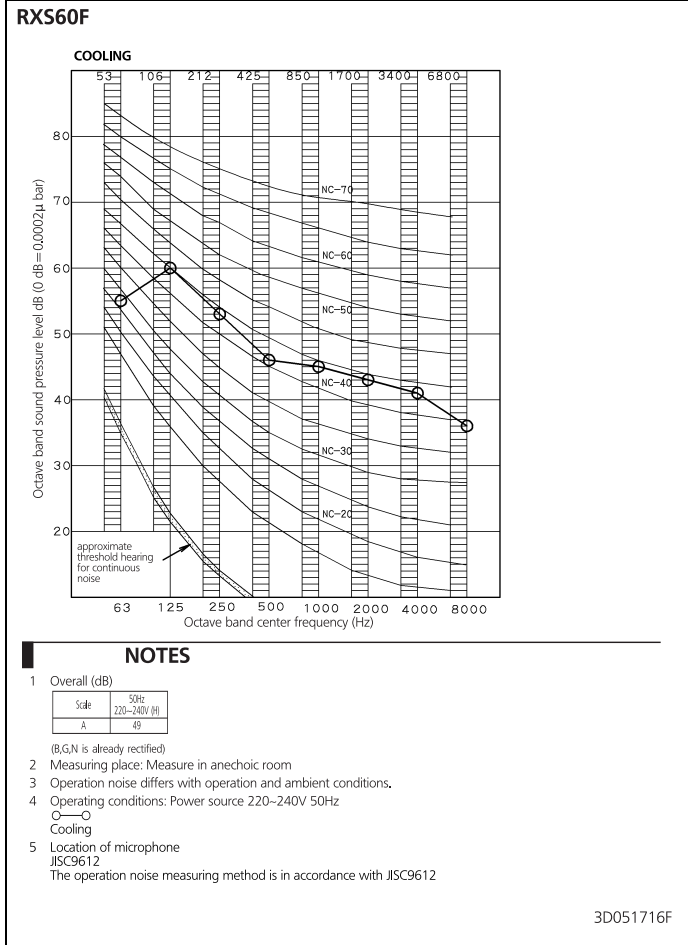

9 Sound data

9 - 2 Sound Pressure Spectrum - Heating

9

RXS60F

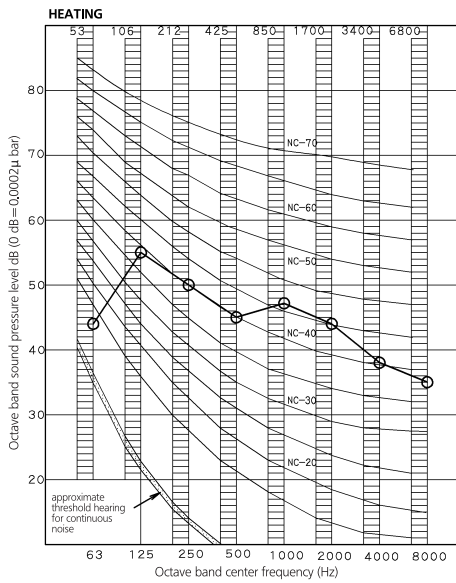

NOTES

- Overall (dB)

Scale	50Hz
A	220-240V (H)
	49

(B.G.N is already rectified)
- Measuring place: Measure in anechoic room
- Operation noise differs with operation and ambient conditions.
- Operating conditions: Power source 220-240V 50Hz
 ○—○ Heating
- Location of microphone
 JISC9612
 The operation noise measuring method is in accordance with JISC9612

3D051716F

RXS71F

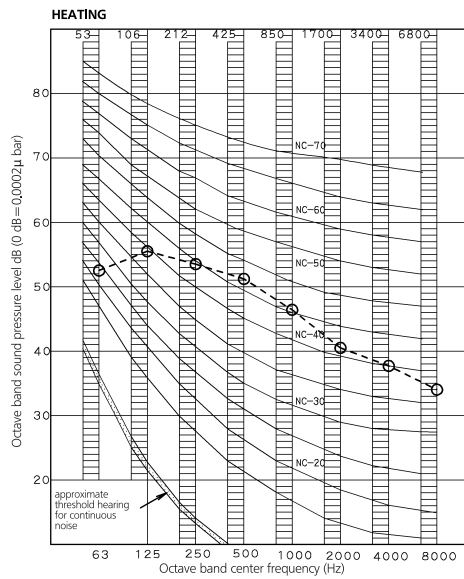

NOTES

- Overall (dB)

Scale	50Hz
A	220-240V (H)
	52

(B.G.N is already rectified)
- Measuring place: Measure in anechoic room
- Operation noise differs with operation and ambient conditions.
- Operating conditions: Power source 220-240V 50Hz
 ○—○ Heating
- Location of microphone
 JISC9612
 The operation noise measuring method is in accordance with JISC9612

3D055789C

10 Operation range

10 - 1 Operation Range

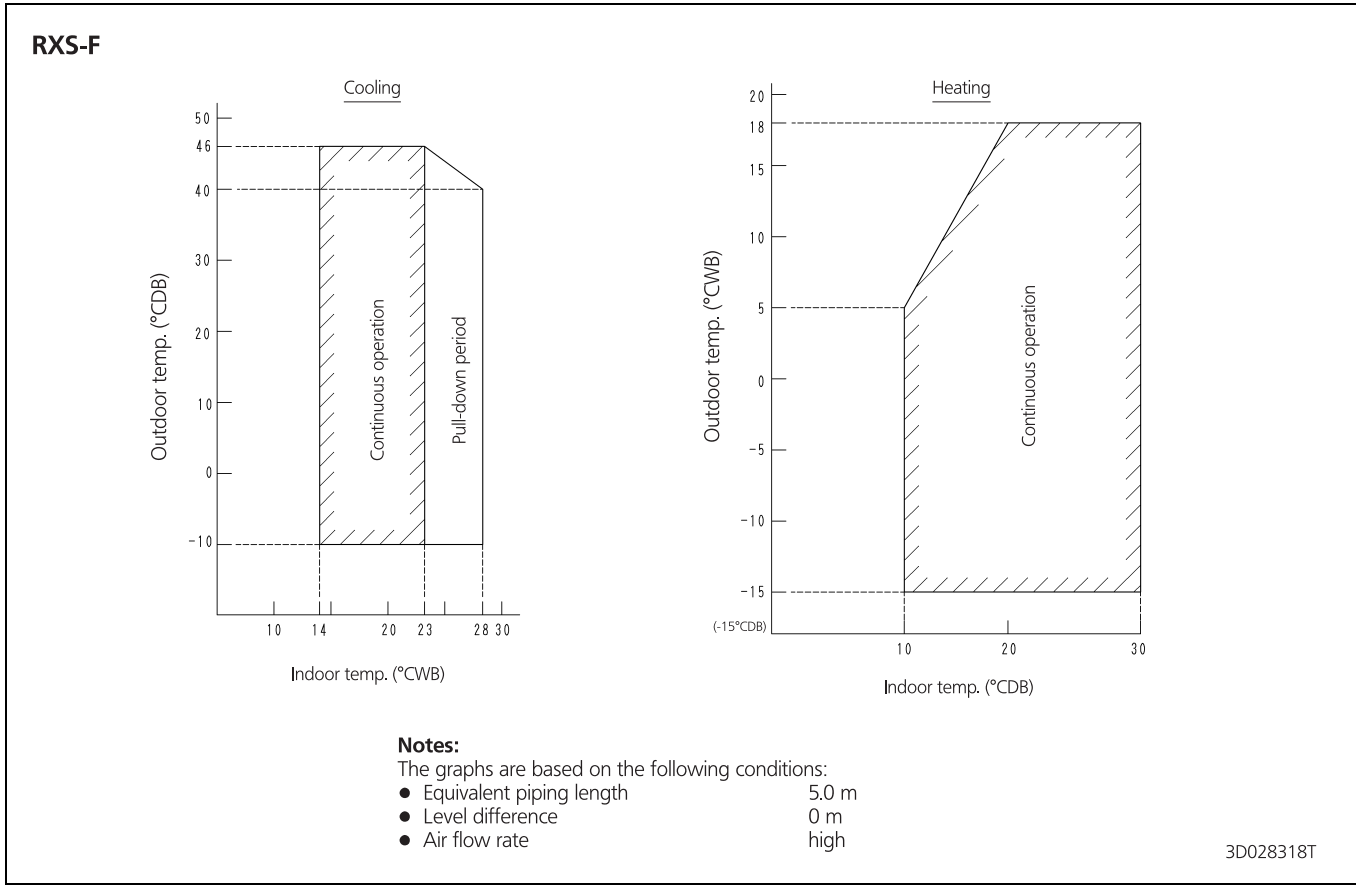



Daikin Europe N.V. participates in the Eurovent Certification programme for Air conditioners (AC), Liquid Chilling Packages (LCP), Air handling units (AHU) and Fan coil units (FCU). Check ongoing validity of certificate online: www.eurovent-certification.com or using: www.certiflash.com

The present leaflet is drawn up by way of information only and does not constitute an offer binding upon Daikin Europe N.V.. Daikin Europe N.V. has compiled the content of this leaflet to the best of its knowledge. No express or implied warranty is given for the completeness, accuracy, reliability or fitness for particular purpose of its content and the products and services presented therein. Specifications are subject to change without prior notice. Daikin Europe N.V. explicitly rejects any liability for any direct or indirect damage, in the broadest sense, arising from or related to the use and/or interpretation of this leaflet. All content is copyrighted by Daikin Europe N.V.

BARCODE

Daikin products are distributed by: