

DAIKIN

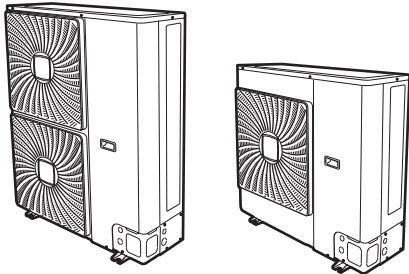

Installation manual

Split system air conditioners



AZQS100B8V1B
AZQS125B8V1B
AZQS140B8V1B

AZQS100B7Y1B
AZQS125B7Y1B
AZQS140B7Y1B

Installation manual
Split system air conditioners

English

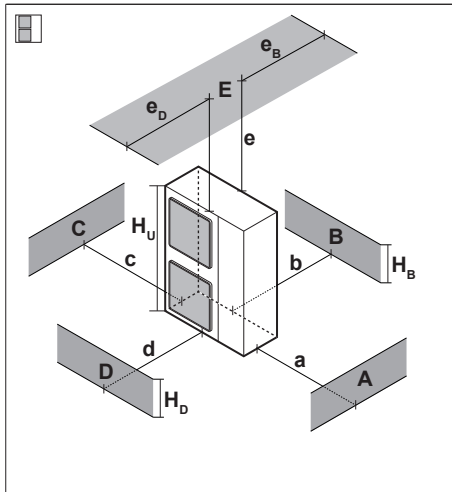

A~E	H_B H_D H_U		(mm)						
			a	b	c	d	e	e_B	e_D
B	—			≥ 100					
A, B, C	—		≥ 100	≥ 100	≥ 100				
B, E	—			≥ 100			≥ 1000	≤ 500	
A, B, C, E	—		≥ 150	≥ 150	≥ 150		≥ 1000	≤ 500	
D	—					≥ 500			
D, E	—					≥ 500	≥ 1000	≤ 500	
B, D	$H_B < H_D$	$H_D > H_U$	≥ 100			≥ 500			
	$H_B > H_D$	$H_D < H_U$	≥ 100			≥ 500			
B, D, E	$H_B < H_D$	$H_B \leq \frac{1}{2}H_U$	≥ 250			≥ 750	≥ 1000	≤ 500	
		$\frac{1}{2}H_U < H_B \leq H_U$	≥ 250			≥ 1000	≥ 1000	≤ 500	
		$H_B > H_U$	⊘						
	$H_B > H_D$	$H_D \leq \frac{1}{2}H_U$	≥ 100			≥ 1000	≥ 1000	≤ 500	
	$\frac{1}{2}H_U < H_D \leq H_U$	≥ 200			≥ 1000	≥ 1000	≤ 500		
	$H_D > H_U$	⊘							

1

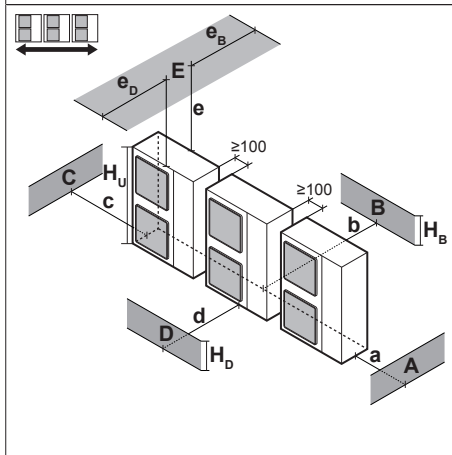

A, B, C	—		≥ 200	≥ 300	≥ 1000				
A, B, C, E	—		≥ 200	≥ 300	≥ 1000		≥ 1000	≤ 500	
D	—					≥ 1000			
D, E	—					≥ 1000	≥ 1000	≤ 500	
B, D	$H_B < H_D$	$H_D > H_U$	≥ 300			≥ 1000			
	$H_B > H_D$	$H_D \leq \frac{1}{2}H_U$	≥ 250			≥ 1500			
		$\frac{1}{2}H_U < H_D \leq H_U$	≥ 300			≥ 1500			
B, D, E	$H_B < H_D$	$H_B \leq \frac{1}{2}H_U$	≥ 300			≥ 1000	≥ 1000	≤ 500	
		$\frac{1}{2}H_U < H_B \leq H_U$	≥ 300			≥ 1250	≥ 1000	≤ 500	
		$H_B > H_U$	⊘						
	$H_B > H_D$	$H_D \leq \frac{1}{2}H_U$	≥ 250			≥ 1500	≥ 1000	≤ 500	
		$\frac{1}{2}H_U < H_D \leq H_U$	≥ 300			≥ 1500	≥ 1000	≤ 500	
	$H_D > H_U$	⊘							

1

1+2

1

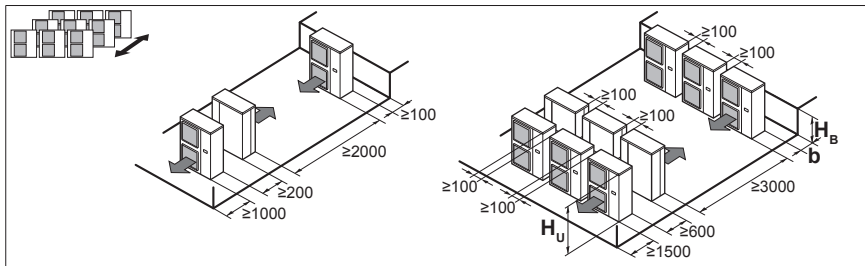

H_B H_U	b (mm)
$H_B \leq \frac{1}{2}H_U$	$b \geq 250$
$\frac{1}{2}H_U < H_B \leq H_U$	$b \geq 300$
$H_B > H_U$	⊘

2

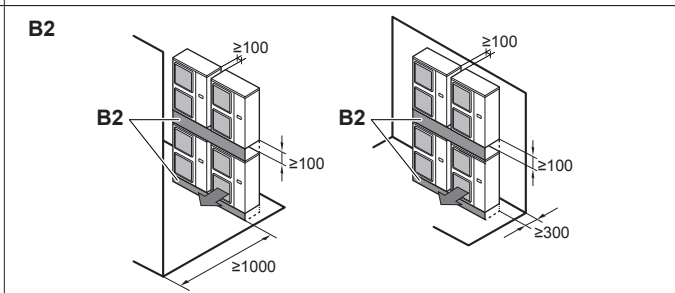
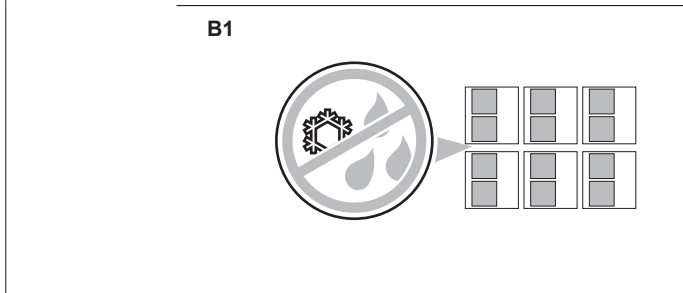
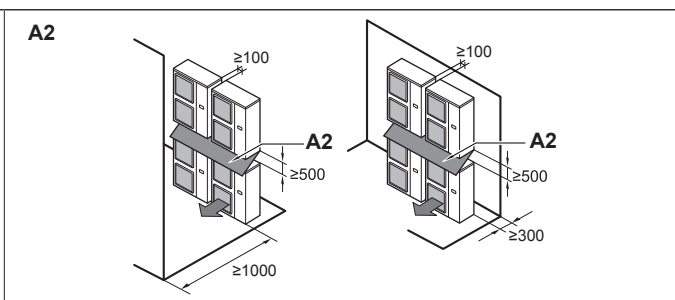
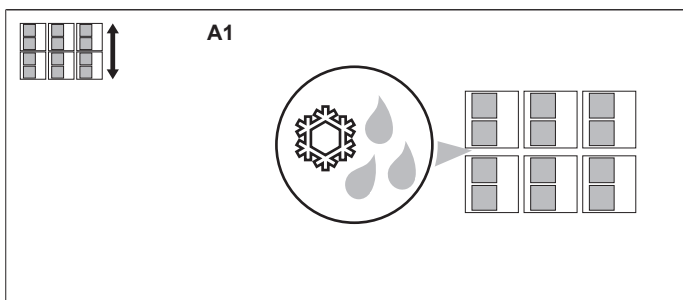

3

Table of contents

1	About the documentation	4
1.1	About this document.....	4
2	About the box	4
2.1	Outdoor unit.....	4
2.1.1	To remove the accessories from the outdoor unit.....	4
3	Preparation	4
3.1	Preparing installation site	4
3.1.1	Installation site requirements of the outdoor unit	4
4	Installation	5
4.1	Mounting the outdoor unit.....	5
4.1.1	To provide the installation structure	5
4.1.2	To install the outdoor unit.....	5
4.1.3	To provide drainage	5
4.1.4	To prevent the outdoor unit from falling over	6
4.2	Connecting the refrigerant piping	6
4.2.1	To connect the refrigerant piping to the outdoor unit ..	6
4.2.2	To determine if oil traps are required.....	7
4.3	Checking the refrigerant piping	7
4.3.1	Checking refrigerant piping: Setup.....	7
4.3.2	To check for leaks.....	7
4.3.3	To perform vacuum drying	7
4.4	Charging refrigerant	7
4.4.1	To determine the additional refrigerant amount.....	7
4.4.2	To determine the complete recharge amount.....	8
4.4.3	Charging refrigerant: Setup.....	8
4.4.4	To charge refrigerant	8
4.4.5	To fix the fluorinated greenhouse gases label	8
4.5	Connecting the electrical wiring.....	8
4.5.1	About electrical compliance	8
4.5.2	Specifications of standard wiring components.....	8
4.5.3	To connect the electrical wiring on the outdoor unit....	9
4.6	Finishing the outdoor unit installation	9
4.6.1	To finish the outdoor unit installation	9
4.6.2	To check the insulation resistance of the compressor	10
5	Commissioning	10
5.1	Checklist before commissioning	10
5.2	To perform a test run.....	10
5.3	Error codes when performing a test run	10
6	Technical data	12
6.1	Service space: Outdoor unit.....	12
6.2	Piping diagram: Outdoor unit.....	12
6.3	Wiring diagram: Outdoor unit	13

1 About the documentation

1.1 About this document

Target audience

Authorised installers



INFORMATION

This appliance is intended to be used by expert or trained users in shops, in light industry and on farms, or for commercial use by lay persons.

Documentation set

This document is part of a documentation set. The complete set consists of:

- **General safety precautions:**
 - Safety instructions that you must read before installing
 - Format: Paper (in the box of the outdoor unit)
- **Outdoor unit installation manual:**
 - Installation instructions
 - Format: Paper (in the box of the outdoor unit)
- **Installer reference guide:**
 - Preparation of the installation, reference data,...
 - Format: Digital files on <http://www.daikineurope.com/support-and-manuals/product-information/>

Latest revisions of the supplied documentation may be available on the regional Daikin website or via your dealer.

The original documentation is written in English. All other languages are translations.

Technical engineering data

- A **subset** of the latest technical data is available on the regional Daikin website (publicly accessible).
- The **full set** of latest technical data is available on the Daikin extranet (authentication required).

2 About the box

2.1 Outdoor unit

2.1.1 To remove the accessories from the outdoor unit

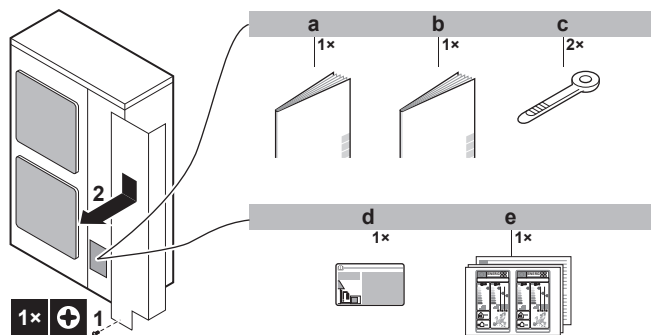

- a General safety precautions
- b Outdoor unit installation manual
- c Cable tie
- d Fluorinated greenhouse gases label
- e Energy label

3 Preparation

3.1 Preparing installation site

3.1.1 Installation site requirements of the outdoor unit

Mind the spacing guidelines. See the "Technical data" chapter, and the figures on the inside of the front cover.



INFORMATION

The sound pressure level is less than 70 dBA.

The outdoor unit is designed for outdoor installation only, and for ambient temperatures ranging:

Model	Cooling	Heating
AZQS	-5~46°C	-15~15.5°C

4 Installation

4.1 Mounting the outdoor unit

4.1.1 To provide the installation structure

Prepare 4 sets of anchor bolts, nuts and washers (field supply) as follows:

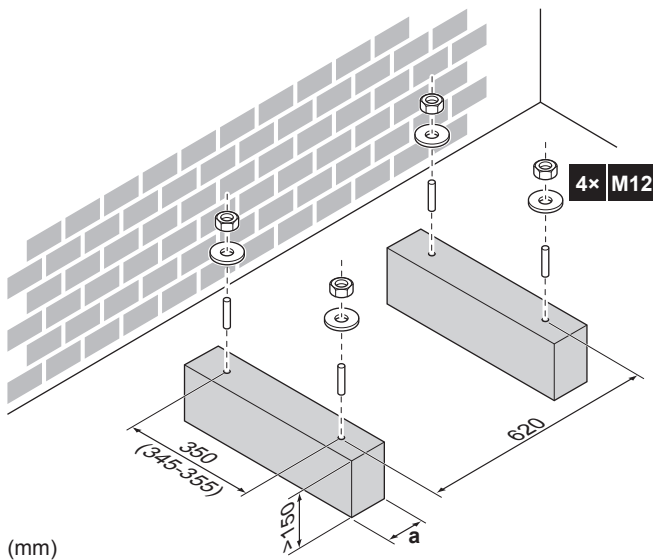

a Make sure not to cover the drain holes.



INFORMATION

The recommended height of the upper protruding part of the bolts is 20 mm.

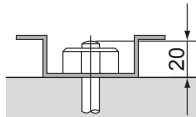

NOTICE

Fix the outdoor unit to the foundation bolts using nuts with resin washers (a). If the coating on the fastening area is stripped off, the nuts rust easily.



4.1.2 To install the outdoor unit

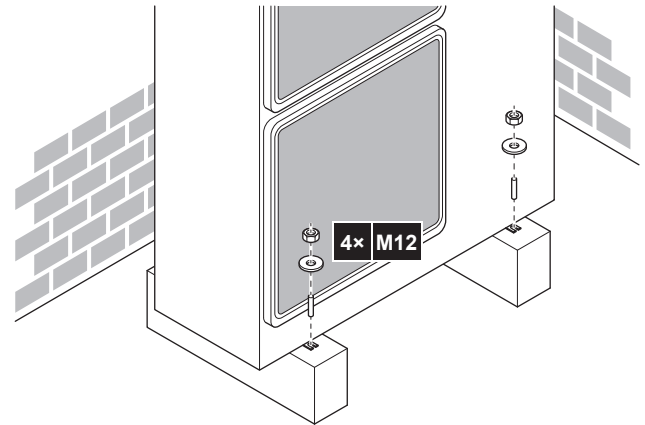

4.1.3 To provide drainage

Make sure that condensation water can be evacuated properly.



INFORMATION

If necessary, you can use a drain plug kit (field supply) to prevent drain water from dripping.



NOTICE

If drain holes of the outdoor unit are covered by a mounting base or by floor surface, raise the unit to provide a free space of more than 150 mm under the outdoor unit.

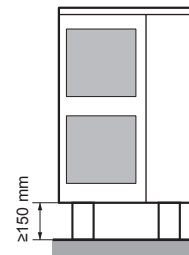

Drain holes (dimensions in mm)

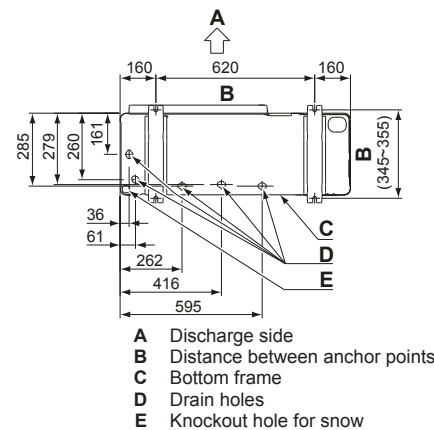

- A Discharge side
- B Distance between anchor points
- C Bottom frame
- D Drain holes
- E Knockout hole for snow

Snow

In regions with snowfall, snow might build up and freeze between the heat exchanger and the external plate. This might decrease the operating efficiency. To prevent this:

- 1 Drill (a, 4×) and remove the knockout hole (b).

4 Installation

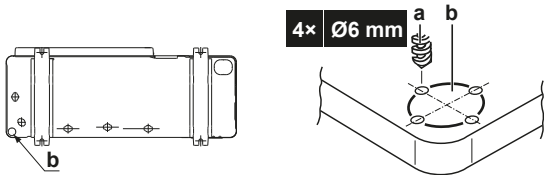

- 2 Remove the burrs, and paint the edges and areas around the edges using repair paint to prevent rusting.

4.1.4 To prevent the outdoor unit from falling over

- 1 Prepare 2 cables as indicated in the following illustration (field supply).
- 2 Place the 2 cables over the outdoor unit.
- 3 Insert a rubber sheet between the cables and the outdoor unit to prevent the cable from scratching the paint (field supply).
- 4 Attach the cable's ends. Tighten those ends.

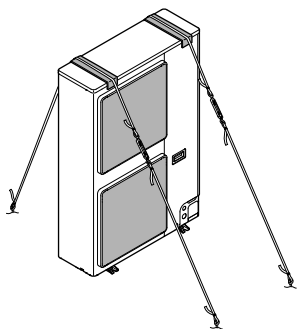

4.2 Connecting the refrigerant piping



DANGER: RISK OF BURNING

4.2.1 To connect the refrigerant piping to the outdoor unit

- 1 Do the following:
 - Remove the service cover (a) with screw (b).
 - Remove the piping intake plate (c) with screw (d).

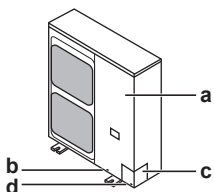

- 2 Choose a piping route (a, b, c or d).

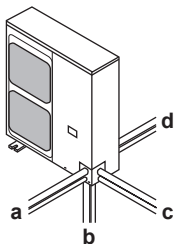

- 3 If you have chosen the downwards piping route:
 - Drill (a, 4×) and remove the knockout hole (b).
 - Cut out the slits (c) with a metal saw.

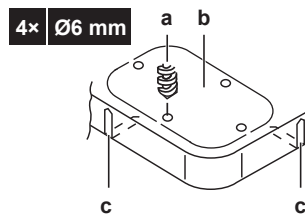

- 4 Do the following:

- Connect the liquid pipe (a) to the liquid stop valve.
- Connect the gas pipe (b) to the gas stop valve.

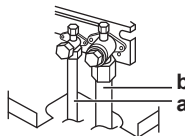

- 5 Do the following:

- Insulate the liquid piping (a) and the gas piping (b).
- Wind heat insulation around the curves, and then cover it with vinyl tape (c).
- Make sure the field piping does not touch any compressor components (d).
- Seal the insulation ends (sealant etc.) (e).

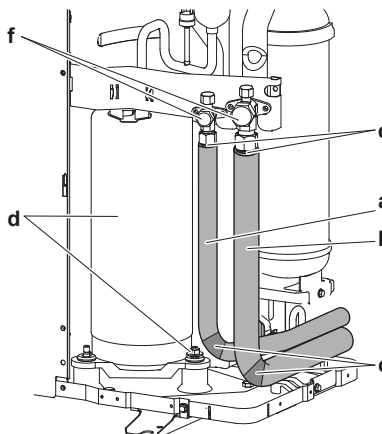

- 6 If the outdoor unit is installed above the indoor unit, cover the stop valves (f, see above) with sealing material to prevent condensed water on the stop valves from moving to the indoor unit.



NOTICE

Any exposed piping might cause condensation.

- 7 Reattach the service cover and the piping intake plate.
- 8 Seal all gaps (example: a) to prevent snow and small animals from entering the system.

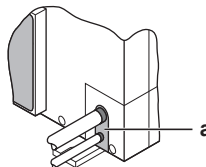

WARNING

Provide adequate measures to prevent that the unit can be used as a shelter by small animals. Small animals that make contact with electrical parts can cause malfunctions, smoke or fire.



NOTICE

Make sure to open the stop valves after installing the refrigerant piping and performing vacuum drying. Running the system with the stop valves closed may break the compressor.

4.2.2 To determine if oil traps are required

If oil flows back into the outdoor unit's compressor, this might cause liquid compression or deterioration of oil return. Oil traps in the rising gas piping can prevent this.

If	Then
The indoor unit is installed higher than the outdoor unit	Install an oil trap every 10 m (height difference). a Rising gas piping with oil trap b Liquid piping
The outdoor unit is installed higher than the indoor unit	Oil traps are NOT required.

4.3 Checking the refrigerant piping

4.3.1 Checking refrigerant piping: Setup

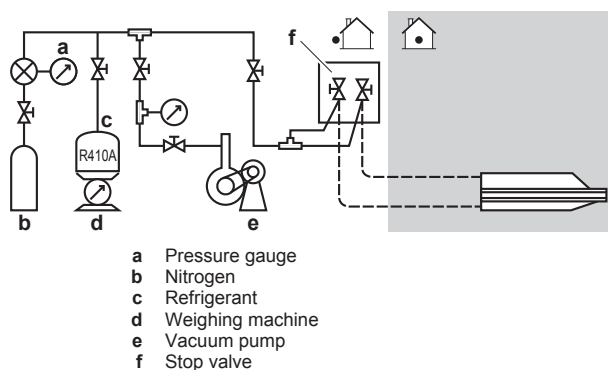

4.3.2 To check for leaks



NOTICE

Do NOT exceed the unit's maximum working pressure (see "PS High" on the unit name plate).



NOTICE

Make sure to use a recommended bubble test solution from your wholesaler. Do not use soap water, which may cause cracking of flare nuts (soap water may contain salt, which absorbs moisture that will freeze when the piping gets cold), and/or lead to corrosion of flared joints (soap water may contain ammonia which causes a corrosive effect between the brass flare nut and the copper flare).

- 1 Charge the system with nitrogen gas up to a gauge pressure of at least 200 kPa (2 bar). It is recommended to pressurize to 3000 kPa (30 bar) in order to detect small leaks.
- 2 Check for leaks by applying the bubble test solution to all connections.
- 3 Discharge all nitrogen gas.

4.3.3 To perform vacuum drying

- 1 Vacuum the system until the pressure on the manifold indicates -0.1 MPa (-1 bar).
- 2 Leave as is for 4-5 minutes and check the pressure:

If the pressure...	Then...
Does not change	There is no moisture in the system. This procedure is finished.
Increases	There is moisture in the system. Go to the next step.

- 3 Evacuate for at least 2 hours to a pressure on the manifold of -0.1 MPa (-1 bar).
- 4 After turning OFF the pump, check the pressure for at least 1 hour.
- 5 If you do NOT reach the target vacuum or cannot maintain the vacuum for 1 hour, do the following:
 - Check for leaks again.
 - Perform vacuum drying again.



NOTICE

Make sure to open the stop valves after installing the refrigerant piping and performing vacuum drying. Running the system with the stop valves closed may break the compressor.

4.4 Charging refrigerant

4.4.1 To determine the additional refrigerant amount

To determine if adding additional refrigerant is necessary

If	Then
$L1 \leq 30$ m (chargeless length)	You do not have to add additional refrigerant.
$L1 > 30$ m	You must add additional refrigerant. For future servicing, encircle the selected amount in the tables below.



INFORMATION

Piping length is the one way length of liquid piping.

To determine the additional refrigerant amount (R in kg)

	30~40 m	40~50 m
R:	0.5 kg	1.0 kg



INFORMATION

For details about the combination of your outdoor and indoor unit, see the engineering databook.

4 Installation

4.4.2 To determine the complete recharge amount

Model	L1 (m)				
	5~10	10~20	20~30	30~40	40~50
AZQS100+125	1.9	2.4	2.9	3.4	3.9
AZQS140	3.0	3.5	4.0	4.5	5.0



INFORMATION

For details about the combination of your outdoor and indoor unit, see the engineering databook.

4.4.3 Charging refrigerant: Setup

See "4.3.1 Checking refrigerant piping: Setup" on page 7.

4.4.4 To charge refrigerant



WARNING

- Only use R410A as refrigerant. Other substances may cause explosions and accidents.
- R410A contains fluorinated greenhouse gases. Its global warming potential (GWP) value is 2087.5. Do NOT vent these gases into the atmosphere.
- When charging refrigerant, always use protective gloves and safety glasses.

Prerequisite: Before charging refrigerant, make sure the refrigerant piping is connected and checked (leak test and vacuum drying).

- Connect the refrigerant cylinder to both the service port of the gas stop valve and the service port of the liquid stop valve.
- Charge the additional refrigerant amount.
- Open the stop valves.

4.4.5 To fix the fluorinated greenhouse gases label

- Fill in the label as follows:

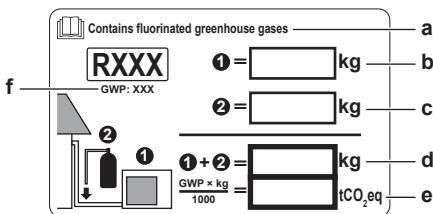

- If a multilingual fluorinated greenhouse gases label is delivered with the unit (see accessories), peel off the applicable language and stick it on top of a.
- Factory refrigerant charge: see unit name plate
- Additional refrigerant amount charged
- Total refrigerant charge
- Greenhouse gas emissions** of the total refrigerant charge expressed as tonnes CO₂-equivalent
- GWP = Global warming potential

4.5.2 Specifications of standard wiring components

Component		AZQS_V1			AZQS_Y1		
		100	125	140	100	125	140
Power supply cable	MCA ^(a)	29.5 A	31.5 A	32.8 A	15.2 A	17.2 A	21.8 A
	Voltage	230 V			400 V		
	Phase	1~			3N~		
	Frequency	50 Hz					
	Wire sizes	Must comply with applicable legislation					
Interconnection cables		Minimum cable section of 2.5 mm ² and applicable for 230 V					



NOTICE

In Europe, the **greenhouse gas emissions** of the total refrigerant charge in the system (expressed as tonnes CO₂-equivalent) is used to determine the maintenance intervals. Follow the applicable legislation.

Formula to calculate the greenhouse gas emissions:
GWP value of the refrigerant × Total refrigerant charge [in kg] / 1000

- Fix the label on the inside of the outdoor unit. There is a dedicated place for it on the wiring diagram label.

4.5 Connecting the electrical wiring



DANGER: RISK OF ELECTROCUTION



WARNING

ALWAYS use multicore cable for power supply cables.



CAUTION

For use of units in applications with temperature alarm settings it is recommended to foresee a delay of 10 minutes for signalling the alarm in case the alarm temperature is exceeded. The unit may stop for several minutes during normal operation for "defrosting the unit", or when in "thermostat stop" operation.

4.5.1 About electrical compliance

AZQS_V1 + AZQS125_Y1

Equipment complying with EN/IEC 61000-3-12 (European/International Technical Standard setting the limits for harmonic currents produced by equipment connected to public low-voltage systems with input current >16 A and ≤75 A per phase.)

AZQS140_Y1

Equipment complying with:

- EN/IEC 61000-3-12** provided that the short-circuit power S_{sc} is greater than or equal to the minimum S_{sc} value at the interface point between the user's supply and the public system.
- EN/IEC 61000-3-12 = European/International Technical Standard setting the limits for harmonic currents produced by equipment connected to public low-voltage systems with input current >16 A and ≤75 A per phase.
- It is the responsibility of the installer or user of the equipment to ensure, by consultation with the distribution network operator if necessary, that the equipment is connected only to a supply with a short-circuit power S_{sc} greater than or equal to the minimum S_{sc} value.

Model	Minimum S_{sc} value
AZQS140_Y1	1170 kVA ^(a)

- (a) This is the most stringent value. For specific product data, see the databooks.

Component	AZQS_V1			AZQS_Y1		
	100	125	140	100	125	140
Recommended field fuse	32 A			16 A	20 A	25 A
Earth leakage circuit breaker	Must comply with applicable legislation					

(a) MCA=Minimum circuit ampacity. Stated values are maximum values (see electrical data of combination with indoor units for exact values).

4.5.3 To connect the electrical wiring on the outdoor unit



NOTICE

- Follow the wiring diagram (delivered with the unit, located at the inside of the service cover).
- Make sure the electrical wiring does NOT obstruct proper reattachment of the service cover.

- Remove the service cover.
- Connect the interconnection cable and power supply as follows:

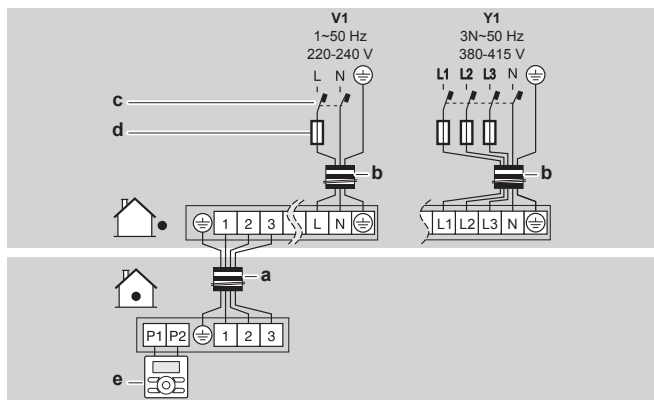

- a Interconnection cable
- b Power supply cable
- c Earth leakage circuit breaker
- d Fuse
- e User interface

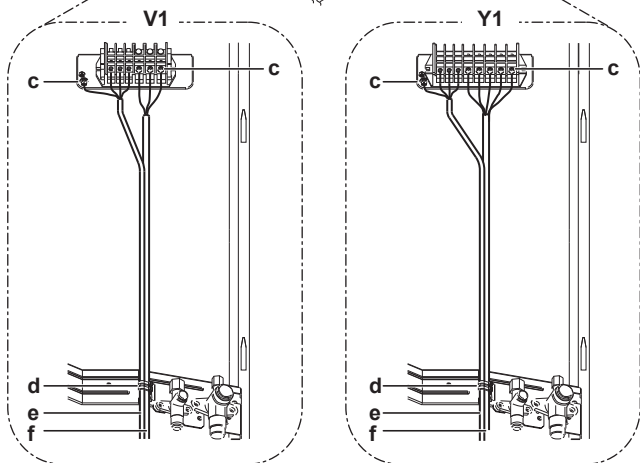
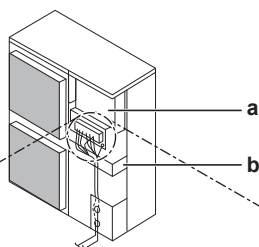

- a Switch box
- b Stop valve attachment plate
- c Earth
- d Cable tie
- e Interconnection cable
- f Power supply cable

- Fix the cables (power supply and interconnection cable) with a cable tie to the stop valve attachment plate.
- Route the wiring through the frame and connect it to it.

<p>Routing through the frame</p>	<p>Choose one of the 3 possibilities:</p> <p>a Power supply cable b Interconnection cable</p>
<p>Connecting to the frame</p>	<p>When cables are routed from the unit, a protection sleeve for the conduits (PG insertions) can be inserted at the knockout hole.</p> <p>When you do not use a wire conduit, protect the wires with vinyl tubes to prevent the edge of the knockout hole from cutting the wires.</p> <p>A Inside of the outdoor unit B Outside of the outdoor unit a Wire b Bush c Nut d Frame e Hose</p>

- Reattach the service cover.
- Connect an earth leakage circuit breaker and fuse to the power supply line.

4.6 Finishing the outdoor unit installation

4.6.1 To finish the outdoor unit installation

- Insulate and fix the refrigerant piping and interconnection cable as follows:

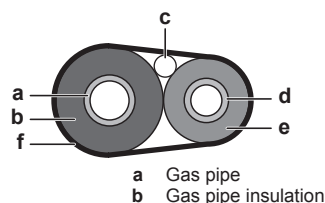

5 Commissioning

- c Interconnection cable
- d Liquid pipe
- e Liquid pipe insulation
- f Finishing tape

- 2 Install the service cover.

4.6.2 To check the insulation resistance of the compressor

NOTICE

If, after installation, refrigerant accumulates in the compressor, the insulation resistance over the poles can drop, but if it is at least 1 MΩ, then the unit will not break down.

- Use a 500 V mega-tester when measuring insulation.
- Do not use a mega-tester for low-voltage circuits.

- 1 Measure the insulation resistance over the poles.

If	Then
≥1 MΩ	Insulation resistance is OK. This procedure is finished.
<1 MΩ	Insulation resistance is not OK. Go to the next step.

- 2 Turn ON the power and leave it on for 6 hours.

Result: The compressor will heat up and evaporate any refrigerant in the compressor.

- 3 Measure the insulation resistance again.

5 Commissioning

NOTICE

NEVER operate the unit without thermistors and/or pressure sensors/switches. Burning of the compressor might result.

5.1 Checklist before commissioning

Do NOT operate the system before the following checks are OK:

<input type="checkbox"/>	You read the complete installation instructions, as described in the installer reference guide .
<input type="checkbox"/>	The indoor units are properly mounted.
<input type="checkbox"/>	In case a wireless user interface is used: The indoor unit decoration panel with infrared receiver is installed.
<input type="checkbox"/>	The outdoor unit is properly mounted.
<input type="checkbox"/>	The following field wiring has been carried out according to this document and the applicable legislation: <ul style="list-style-type: none"> ▪ Between the local supply panel and the outdoor unit ▪ Between the outdoor unit and the indoor unit
<input type="checkbox"/>	There are NO missing phases or reversed phases .
<input type="checkbox"/>	The system is properly earthed and the earth terminals are tightened.
<input type="checkbox"/>	The fuses or locally installed protection devices are installed according to this document, and have not been bypassed.
<input type="checkbox"/>	The power supply voltage matches the voltage on the identification label of the unit.
<input type="checkbox"/>	There are NO loose connections or damaged electrical components in the switch box.

<input type="checkbox"/>	The insulation resistance of the compressor is OK.
<input type="checkbox"/>	There are NO damaged components or squeezed pipes on the inside of the indoor and outdoor units.
<input type="checkbox"/>	There are NO refrigerant leaks .
<input type="checkbox"/>	The correct pipe size is installed and the pipes are properly insulated.
<input type="checkbox"/>	The stop valves (gas and liquid) on the outdoor unit are fully open.

5.2 To perform a test run

NOTICE

Do not interrupt the test run.

INFORMATION

In case you have to redo the test run, see the service manual.

- 1 Perform introductory steps.

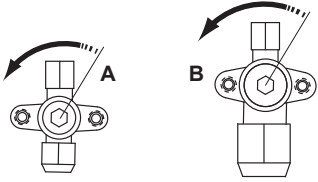
#	Action
1	Open the liquid stop valve (A) and gas stop valve (B) by removing the stem cap and turning counterclockwise with a hex wrench until it stops. 
2	Close the service cover to prevent electric shocks.
3	Turn ON power for at least 6 hours before starting operation to protect the compressor.
4	On the user interface, set the unit to cooling operation mode.

- 2 On the user interface, turn ON the unit.

Result: The test run starts automatically. During the test run, the H2P test LED is ON. When the test run is done, the LED turns OFF.

5.3 Error codes when performing a test run

If the installation of the outdoor unit has NOT been done correctly, the following error codes may be displayed on the user interface:

Error code	Possible cause
Nothing displayed (the currently set temperature is not displayed)	<ul style="list-style-type: none"> ▪ The wiring is disconnected or there is a wiring error (between power supply and outdoor unit, between outdoor unit and indoor units, between indoor unit and user interface). ▪ The fuse on the outdoor unit PCB has blown out.
E3, E4 or L8	<ul style="list-style-type: none"> ▪ The stop valves are closed. ▪ The air inlet or air outlet is blocked.
E7	<p>There is a missing phase in case of three-phase power supply units.</p> <p>Note: Operation will be impossible. Turn OFF the power, recheck the wiring, and switch two of the three electrical wires.</p>
L4	The air inlet or air outlet is blocked.

Error code	Possible cause
U0	The stop valves are closed.
U2	<ul style="list-style-type: none"> ▪ There is a voltage imbalance. ▪ There is a missing phase in case of three-phase power supply units. Note: Operation will be impossible. Turn OFF the power, recheck the wiring, and switch two of the three electrical wires.
U4 or UF	The inter-unit branch wiring is not correct.
UA	The outdoor and indoor unit are incompatible.

**NOTICE**

- The reversed phase protection detector of this product only functions when the product starts up. Consequently reversed phase detection is not performed during normal operation of the product.
- The reversed phase protection detector is designed to stop the product in the event of an abnormality when the product is started up.
- Replace two of the three phases (L1, L2, and L3) during reverse-phase protection abnormality.

6 Technical data

6 Technical data

A **subset** of the latest technical data is available on the regional Daikin website (publicly accessible). The **full set** of latest technical data is available on the Daikin extranet (authentication required).

6.1 Service space: Outdoor unit

Suction side	In the illustrations below, the service space at the suction side is based on 35°C DB and cooling operation. Forsee more space in the following cases: <ul style="list-style-type: none"> When the suction side temperature regularly exceeds this temperature. When the heat load of the outdoor units is expected to regularly exceed the maximum operating capacity.
Discharge side	Take refrigerant piping work into account when positioning the units. If your layout does not match any of the layouts below, contact your dealer.

Single unit () | Single row of units ()

See figure 1 on the inside of the front cover.

- A,B,C,D** Obstacles (walls/baffle plates)
- E** Obstacle (roof)
- a,b,c,d,e** Minimum service space between the unit and obstacles A, B, C, D and E
- e_B** Maximum distance between the unit and the edge of obstacle B, in the direction of obstacle B
- e_D** Maximum distance between the unit and the edge of obstacle E, in the direction of obstacle D
- H_U** Height of the unit
- H_B,H_D** Height of obstacles B and D
- 1** Seal the bottom of the installation frame to prevent discharged air from flowing back to the suction side through the bottom of the unit.
- 2** Maximum two units can be installed.
- ⊘** Not allowed

Multiple rows of units ()

See figure 2 on the inside of the front cover.

Stacked units (max. 2 levels) ()

See figure 3 on the inside of the front cover.

- A1⇒A2** (A1) If there is danger of drainage dripping and freezing between the upper and lower units...
(A2) Then install a **roof** between the upper and lower units. Install the upper unit high enough above the lower unit to prevent ice buildup at the upper unit's bottom plate.
- B1⇒B2** (B1) If there is no danger of drainage dripping and freezing between the upper and lower units...
(B2) Then it is not required to install a roof, but **seal the gap** between the upper and lower units to prevent discharged air from flowing back to the suction side through the bottom of the unit.

6.2 Piping diagram: Outdoor unit

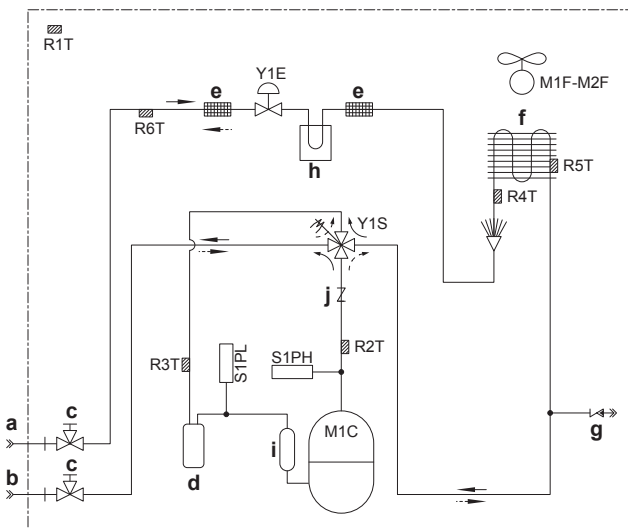

- a** Field piping (liquid: Ø9.5 flare connection)
- b** Field piping (gas: Ø15.9 flare connection)
- c** Stop valve (with service port 5/16")
- d** Accumulator
- e** Filter
- f** Heat exchanger
- g** Internal service port 5/16"
- h** Switch box cooling (only for AZQS_V1)
- i** Compressor accumulator
- j** Check valve (only for AZQS100 and AZQS125)
- M1C** Motor (compressor)
- M1F-M2F** Motor (upper and lower fan)
- R1T** Thermistor (air)
- R2T** Thermistor (discharge)
- R3T** Thermistor (suction)
- R4T** Thermistor (heat exchanger)
- R5T** Thermistor (heat exchanger middle)
- R6T** Thermistor (liquid)
- S1PH** High pressure switch
- S1PL** Low pressure switch (only for AZQS_V1)
- Y1E** Electronic expansion valve
- Y1S** Solenoid valve (4-way valve)
- Heating
- ⇄ Cooling

6.3 Wiring diagram: Outdoor unit

The wiring diagram is delivered with the unit, located at the inside of the service cover.

Notes for AZQS_V1:

- 1 Symbols (see legend).
- 2 Colours (see legend).
- 3 This wiring diagram applies only to the outdoor unit.
- 4 Refer to the wiring diagram sticker (on the back of the service cover) for how to use the BS1~BS4 and DS1 switches.
- 5 When operating, do not short-circuit protective devices S1PH and S1PL.
- 6 Refer to the service manual for instructions on how to set the selector switches (DS1). The factory setting of all switches is OFF.
- 7 Refer to the combination table and the option manual for how to connect the wiring to X6A, X28A and X77A.

Notes for AZQS_Y1:

- 1 This wiring diagram applies only to the outdoor unit.
- 2 Refer to the combination table and the option manual for how to connect the wiring to X6A, X28A and X77A.
- 3 Refer to the wiring diagram sticker (on the back of the service cover) for how to use the BS1~BS4 and DS1 switches.
- 4 When operating, do not short-circuit protective device S1PH.
- 5 Refer to the service manual for instructions on how to set the selector switches (DS1). The factory setting of all switches is OFF.
- 6 Only for 71 class.

Legend for wiring diagrams:

A1P~A2P	Printed circuit board
BS1~BS4	Push button switch
C1~C3	Capacitor
DS1	DIP switch
E1H	Bottom plate heater (option)
F1U~F8U (AZQS100_V1)	<ul style="list-style-type: none"> ▪ F1U, F2U: Fuse ▪ F6U: Fuse (T 3.15 A / 250 V) ▪ F7U, F8U: Fuse (F 1.0 A / 250 V)
F1U~F8U (AZQS125+140_V1)	<ul style="list-style-type: none"> ▪ F1U~F4U: Fuse ▪ F6U: Fuse (T 5.0 A / 250 V) ▪ F7U, F8U: Fuse (F 1.0 A / 250 V)
F1U~F8U (AZQS_Y1)	<ul style="list-style-type: none"> ▪ F1U, F2U: Fuse (31.5 A / 250 V) ▪ F1U (A2P): Fuse (T 5.0 A / 250 V) ▪ F3U~F6U: Fuse (T 6.3 A / 250 V) ▪ F7U, F8U: Fuse (F 1.0 A / 250 V)
H1P~H7P	Light-emitting diode (service monitor is orange)
HAP	Light-emitting diode (service monitor is green)
K1M, K11M	Magnetic contactor
K1R (AZQS_V1)	Magnetic relay (Y1S)
K1R (AZQS_Y1)	<ul style="list-style-type: none"> ▪ K1R (A1P): Magnetic relay (Y1S) ▪ K1R (A2P): Magnetic relay
K2R (AZQS100_V1)	Magnetic relay

K2R (AZQS_Y1)	<ul style="list-style-type: none"> ▪ K2R (A1P): Magnetic relay (E1H option) ▪ K2R (A2P): Magnetic relay
K10R, K13R~K15R	Magnetic relay
K4R	Magnetic relay E1H (option)
L1R~L3R	Reactor
M1C	Motor (compressor)
M1F	Motor (upper fan)
M2F	Motor (lower fan)
PS	Switching power supply
Q1DI	Earth leakage circuit breaker (field supply)
R1~R6	Resistor
R1T	Thermistor (air)
R2T	Thermistor (discharge)
R3T	Thermistor (suction)
R4T	Thermistor (heat exchanger)
R5T	Thermistor (heat exchanger middle)
R6T	Thermistor (liquid)
R7T (AZQS125+140_V1)	Thermistor (fin)
R7T, R8T (AZQS100_V1)	Thermistor (Positive Temperature Coefficient)
R10T (AZQS_Y1)	Thermistor (fin)
RC	Signal receiver circuit
S1PH	High pressure switch
S1PL	Low pressure switch
TC	Signal transmission circuit
V1D~V4D	Diode
V1R	IGBT power module
V2R, V3R	Diode module
V1T~V3T	Insulated gate bipolar transistor (IGBT)
X6A	Connector (option)
X1M	Terminal strip
Y1E	Electronic expansion valve
Y1S	Solenoid valve (4-way valve)
Z1C~Z6C	Noise filter (ferrite core)
Z1F~Z6F	Noise filter

Symbols:

L	Live
N	Neutral
⋮	Field wiring
□□□□	Terminal strip
⊞	Connector
⊞	Relay connector
•	Connection
⊞	Protective earth
⊞	Noiseless earth
○	Terminal
⊞	Option

6 Technical data

Colours:

BLK	Black
BLU	Blue
BRN	Brown
GRN	Green
ORG	Orange
RED	Red
WHT	White
YLW	Yellow

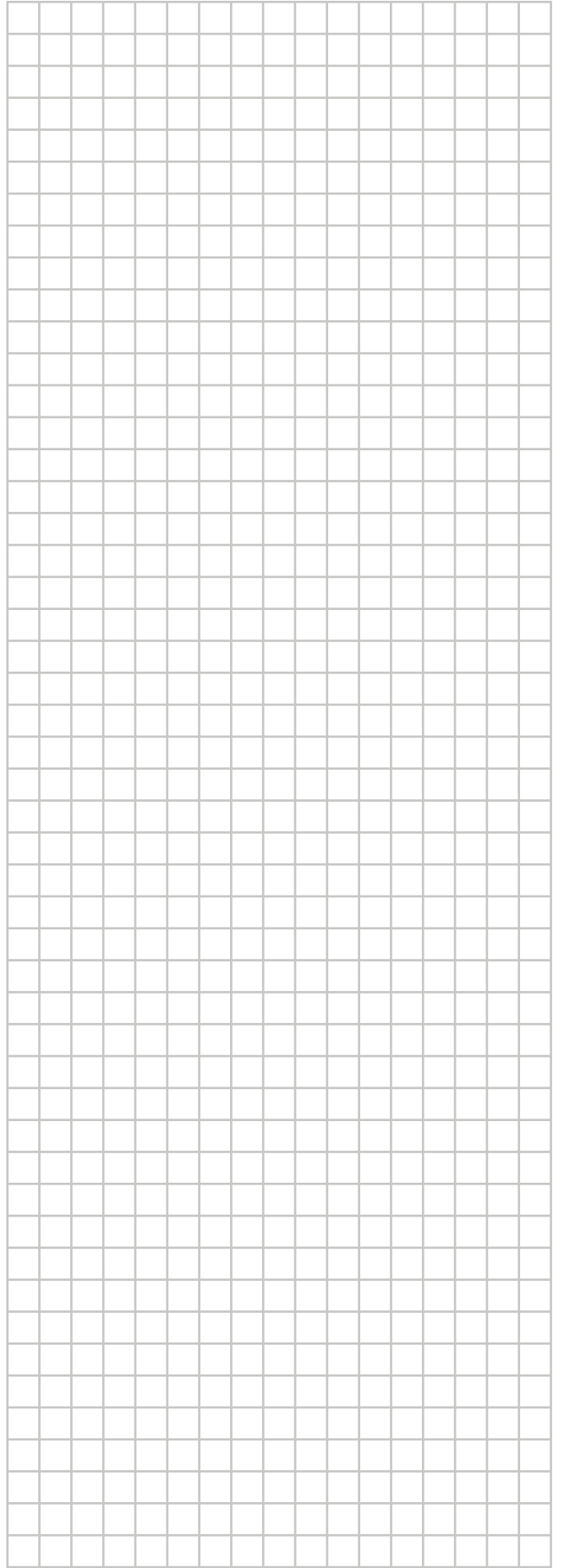
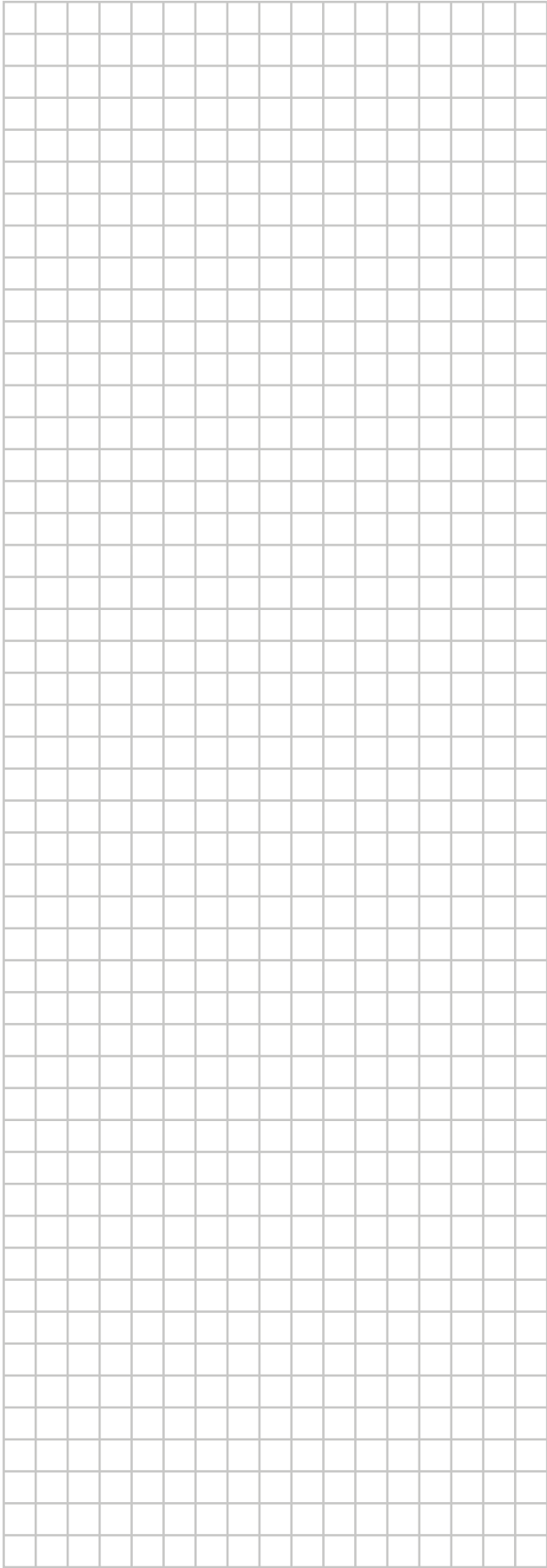

ERC



4P385528-1 C 00000003

Copyright 2014 Daikin

DAIKIN EUROPE N.V.

Zandvoordestraat 300, B-8400 Oostende, Belgium

4P385528-1C 2016.10