

**DAIKIN**



# Installer reference guide

## Split system air conditioners

*Siesta*<sup>®</sup>

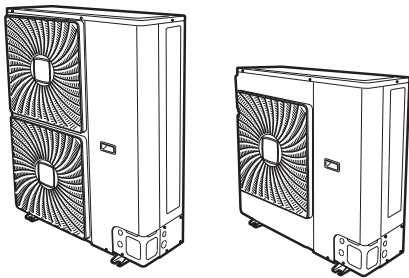

**AZQS100B8V1B**  
**AZQS125B8V1B**  
**AZQS140B8V1B**

**AZQS100B7Y1B**  
**AZQS125B7Y1B**  
**AZQS140B7Y1B**

Installer reference guide  
Split system air conditioners

English

## Table of contents

<b>1</b>	<b>General safety precautions</b>	<b>3</b>	6.5.3	Checking refrigerant piping: Setup.....	14
1.1	About the documentation.....	3	6.5.4	To check for leaks.....	14
1.1.1	Meaning of warnings and symbols.....	3	6.5.5	To perform vacuum drying.....	15
1.2	For the installer.....	3	6.6	Charging refrigerant.....	15
1.2.1	General.....	3	6.6.1	About charging refrigerant.....	15
1.2.2	Installation site.....	3	6.6.2	Precautions when charging refrigerant.....	16
1.2.3	Refrigerant.....	4	6.6.3	To determine the additional refrigerant amount.....	16
1.2.4	Brine.....	4	6.6.4	To determine the complete recharge amount.....	16
1.2.5	Water.....	4	6.6.5	Charging refrigerant: Setup.....	16
1.2.6	Electrical.....	5	6.6.6	To charge refrigerant.....	16
1.2.6	Electrical.....	5	6.6.7	To fix the fluorinated greenhouse gases label.....	17
<b>2</b>	<b>About the documentation</b>	<b>5</b>	6.7	Connecting the electrical wiring.....	17
2.1	About this document.....	5	6.7.1	About connecting the electrical wiring.....	17
2.2	Installer reference guide at a glance.....	5	6.7.2	About electrical compliance.....	17
<b>3</b>	<b>About the box</b>	<b>6</b>	6.7.3	Precautions when connecting the electrical wiring.....	17
3.1	Overview: About the box.....	6	6.7.4	Guidelines when connecting the electrical wiring.....	17
3.2	Outdoor unit.....	6	6.7.5	Specifications of standard wiring components.....	18
3.2.1	To unpack the outdoor unit.....	6	6.7.6	To connect the electrical wiring on the outdoor unit....	18
3.2.2	To handle the outdoor unit.....	6	6.8	Finishing the outdoor unit installation.....	19
3.2.3	To remove the accessories from the outdoor unit.....	6	6.8.1	To finish the outdoor unit installation.....	19
<b>4</b>	<b>About the units and options</b>	<b>6</b>	6.8.2	To close the outdoor unit.....	20
4.1	Overview: About the units and options.....	6	6.8.3	To check the insulation resistance of the compressor.....	20
4.2	Identification.....	6	<b>7</b>	<b>Commissioning</b>	<b>20</b>
4.2.1	Identification label: Outdoor unit.....	6	7.1	Overview: Commissioning.....	20
4.3	Combining units and options.....	7	7.2	Precautions when commissioning.....	20
4.3.1	Possible options for the outdoor unit.....	7	7.3	Checklist before test run.....	20
<b>5</b>	<b>Preparation</b>	<b>7</b>	7.4	To perform a test run.....	21
5.1	Overview: Preparation.....	7	7.5	Error codes when performing a test run.....	21
5.2	Preparing installation site.....	7	<b>8</b>	<b>Hand-over to the user</b>	<b>21</b>
5.2.1	Installation site requirements of the outdoor unit.....	7	<b>9</b>	<b>Maintenance and service</b>	<b>21</b>
5.2.2	Additional installation site requirements of the outdoor unit in cold climates.....	8	9.1	Overview: Maintenance and service.....	21
5.3	Preparing refrigerant piping.....	8	9.2	Maintenance safety precautions.....	22
5.3.1	Refrigerant piping requirements.....	8	9.3	Checklist for yearly maintenance of the outdoor unit.....	22
5.3.2	Refrigerant piping insulation.....	8	<b>10</b>	<b>Troubleshooting</b>	<b>22</b>
5.4	Preparing electrical wiring.....	8	10.1	Overview: Troubleshooting.....	22
5.4.1	About preparing electrical wiring.....	8	10.2	Precautions when troubleshooting.....	22
<b>6</b>	<b>Installation</b>	<b>9</b>	<b>11</b>	<b>Disposal</b>	<b>22</b>
6.1	Overview: Installation.....	9	11.1	Overview: Disposal.....	22
6.2	Opening the units.....	9	11.2	About pump down.....	22
6.2.1	About opening the units.....	9	11.3	To pump down.....	22
6.2.2	To open the outdoor unit.....	9	<b>12</b>	<b>Technical data</b>	<b>23</b>
6.3	Mounting the outdoor unit.....	9	12.1	Overview: Technical data.....	23
6.3.1	About mounting the outdoor unit.....	9	12.2	Dimensions and service space.....	23
6.3.2	Precautions when mounting the outdoor unit.....	9	12.2.1	Dimensions: Outdoor unit.....	23
6.3.3	To provide the installation structure.....	9	12.2.2	Service space: Outdoor unit.....	25
6.3.4	To install the outdoor unit.....	10	12.3	Components.....	27
6.3.5	To provide drainage.....	10	12.3.1	Components: Outdoor unit.....	27
6.3.6	To prevent the outdoor unit from falling over.....	10	12.4	Piping diagram.....	29
6.4	Connecting the refrigerant piping.....	10	12.4.1	Piping diagram: Outdoor unit.....	29
6.4.1	About connecting the refrigerant piping.....	10	12.5	Wiring diagram.....	30
6.4.2	Precautions when connecting the refrigerant piping.....	11	12.5.1	Wiring diagram: Outdoor unit.....	30
6.4.3	Guidelines when connecting the refrigerant piping.....	11	12.6	Technical specifications.....	36
6.4.4	Pipe bending guidelines.....	11	12.6.1	Technical specifications: Outdoor unit.....	36
6.4.5	To flare the pipe end.....	11	<b>13</b>	<b>Glossary</b>	<b>41</b>
6.4.6	To braze the pipe end.....	12			
6.4.7	Using the stop valve and service port.....	12			
6.4.8	To connect the refrigerant piping to the outdoor unit.....	13			
6.4.9	To determine if oil traps are required.....	14			
6.5	Checking the refrigerant piping.....	14			
6.5.1	About checking the refrigerant piping.....	14			
6.5.2	Precautions when checking the refrigerant piping.....	14			

## 1 General safety precautions

### 1.1 About the documentation

- The original documentation is written in English. All other languages are translations.
- The precautions described in this document cover very important topics, follow them carefully.
- The installation of the system, and all activities described in the installation manual and the installer reference guide must be performed by an authorized installer.

#### 1.1.1 Meaning of warnings and symbols

 **DANGER**  
Indicates a situation that results in death or serious injury.

 **DANGER: RISK OF ELECTROCUTION**  
Indicates a situation that could result in electrocution.

 **DANGER: RISK OF BURNING**  
Indicates a situation that could result in burning because of extreme hot or cold temperatures.

 **WARNING**  
Indicates a situation that could result in death or serious injury.

 **CAUTION**  
Indicates a situation that could result in minor or moderate injury.

 **NOTICE**  
Indicates a situation that could result in equipment or property damage.

 **INFORMATION**  
Indicates useful tips or additional information.

### 1.2 For the installer

#### 1.2.1 General

If you are not sure how to install or operate the unit, contact your dealer.

 **NOTICE**  
Improper installation or attachment of equipment or accessories could result in electric shock, short-circuit, leaks, fire or other damage to the equipment. Only use accessories, optional equipment and spare parts made or approved by Daikin.

 **WARNING**  
Make sure installation, testing and applied materials comply with applicable legislation (on top of the instructions described in the Daikin documentation).

 **CAUTION**  
Wear adequate personal protective equipment (protective gloves, safety glasses,...) when installing, maintaining or servicing the system.

 **WARNING**  
Tear apart and throw away plastic packaging bags so that nobody, especially children, can play with them. Possible risk: suffocation.

 **DANGER: RISK OF BURNING**

- Do NOT touch the refrigerant piping, water piping or internal parts during and immediately after operation. It could be too hot or too cold. Give it time to return to normal temperature. If you must touch it, wear protective gloves.
- Do NOT touch any accidental leaking refrigerant.

 **WARNING**  
Provide adequate measures to prevent that the unit can be used as a shelter by small animals. Small animals that make contact with electrical parts can cause malfunctions, smoke or fire.

 **CAUTION**  
Do NOT touch the air inlet or aluminum fins of the unit.

 **NOTICE**

- Do NOT place any objects or equipment on top of the unit.
- Do NOT sit, climb or stand on the unit.

 **NOTICE**  
Works executed on the outdoor unit are best done under dry weather conditions to avoid water ingress.

In accordance with the applicable legislation, it might be necessary to provide a logbook with the product containing at least: information on maintenance, repair work, results of tests, stand-by periods,...

Also, at least, following information must be provided at an accessible place at the product:

- Instructions for shutting down the system in case of an emergency
- Name and address of fire department, police and hospital
- Name, address and day and night telephone numbers for obtaining service

In Europe, EN378 provides the necessary guidance for this logbook.

#### 1.2.2 Installation site

- Provide sufficient space around the unit for servicing and air circulation.
- Make sure the installation site withstands the unit's weight and vibration.
- Make sure the area is well ventilated.
- Make sure the unit is level.

Do NOT install the unit in the following places:

- In potentially explosive atmospheres.
- In places where there is machinery that emits electromagnetic waves. Electromagnetic waves may disturb the control system, and cause malfunction of the equipment.
- In places where there is a risk of fire due to the leakage of flammable gases (example: thinner or gasoline), carbon fibre, ignitable dust.
- In places where corrosive gas (example: sulphurous acid gas) is produced. Corrosion of copper pipes or soldered parts may cause the refrigerant to leak.

# 1 General safety precautions

## 1.2.3 Refrigerant



### NOTICE

Make sure refrigerant piping installation complies with applicable legislation. In Europe, EN378 is the applicable standard.



### NOTICE

Make sure the field piping and connections are not subjected to stress.



### WARNING

During tests, NEVER pressurize the product with a pressure higher than the maximum allowable pressure (as indicated on the nameplate of the unit).



### WARNING

Take sufficient precautions in case of refrigerant leakage. If refrigerant gas leaks, ventilate the area immediately. Possible risks:

- Excessive refrigerant concentrations in a closed room can lead to oxygen deficiency.
- Toxic gas may be produced if refrigerant gas comes into contact with fire.



### WARNING

Always recover the refrigerants. Do NOT release them directly into the environment. Use a vacuum pump to evacuate the installation.



### NOTICE

After all the piping has been connected, make sure there is no gas leak. Use nitrogen to perform a gas leak detection.



### NOTICE

- To avoid compressor breakdown, do NOT charge more than the specified amount of refrigerant.
- When the refrigerant system is to be opened, refrigerant must be treated according to the applicable legislation.



### WARNING

Make sure there is no oxygen in the system. Refrigerant may only be charged after performing the leak test and the vacuum drying.

- In case re-charge is required, refer to the nameplate of the unit. It states the type of refrigerant and necessary amount.
- The unit is factory charged with refrigerant and depending on pipe sizes and pipe lengths some systems require additional charging of refrigerant.
- Only use tools exclusively for the refrigerant type used in the system, this to ensure pressure resistance and prevent foreign materials from entering into the system.
- Charge the liquid refrigerant as follows:

If	Then
A siphon tube is present (i.e., the cylinder is marked with "Liquid filling siphon attached")	Charge with the cylinder upright. 

If	Then
A siphon tube is NOT present	Charge with the cylinder upside down. 

- Open refrigerant cylinders slowly.
- Charge the refrigerant in liquid form. Adding it in gas form may prevent normal operation.



### CAUTION

When the refrigerant charging procedure is done or when pausing, close the valve of the refrigerant tank immediately. If the tank is left with the valve open, the amount of refrigerant which is properly charged may get off point. More refrigerant may be charged by any remaining pressure after the unit has stopped.

## 1.2.4 Brine

If applicable. See the installation manual or installer reference guide of your application for more information.



### WARNING

The selection of the brine MUST be in accordance with the applicable legislation.



### WARNING

Take sufficient precautions in case of brine leakage. If brine leaks, ventilate the area immediately and contact your local dealer.



### WARNING

The ambient temperature inside the unit can get much higher than that of the room, e.g. 70°C. In case of a brine leak, hot parts inside the unit can create a hazardous situation.



### WARNING

The use and installation of the application MUST comply with the safety and environmental precautions specified in the applicable legislation.

## 1.2.5 Water

If applicable. See the installation manual or installer reference guide of your application for more information.



### NOTICE

Make sure water quality complies with EU directive 98/83 EC.

1.2.6 Electrical



**DANGER: RISK OF ELECTROCUTION**

- Turn OFF all power supply before removing the switch box cover, connecting electrical wiring or touching electrical parts.
- Disconnect the power supply for more than 1 minute, and measure the voltage at the terminals of main circuit capacitors or electrical components before servicing. The voltage MUST be less than 50 V DC before you can touch electrical components. For the location of the terminals, see the wiring diagram.
- Do NOT touch electrical components with wet hands.
- Do NOT leave the unit unattended when the service cover is removed.



**WARNING**

If NOT factory installed, a main switch or other means for disconnection, having a contact separation in all poles providing full disconnection under overvoltage category III condition, shall be installed in the fixed wiring.



**WARNING**

- ONLY use copper wires.
- Make sure the field wiring complies with the applicable legislation.
- All field wiring must be performed in accordance with the wiring diagram supplied with the product.
- NEVER squeeze bundled cables and make sure they do not come in contact with the piping and sharp edges. Make sure no external pressure is applied to the terminal connections.
- Make sure to install earth wiring. Do NOT earth the unit to a utility pipe, surge absorber, or telephone earth. Incomplete earth may cause electrical shock.
- Make sure to use a dedicated power circuit. NEVER use a power supply shared by another appliance.
- Make sure to install the required fuses or circuit breakers.
- Make sure to install an earth leakage protector. Failure to do so may cause electric shock or fire.
- When installing the earth leakage protector, make sure it is compatible with the inverter (resistant to high frequency electric noise) to avoid unnecessary opening of the earth leakage protector.

Install power cables at least 1 meter away from televisions or radios to prevent interference. Depending on the radio waves, a distance of 1 meter may not be sufficient.



**WARNING**

- After finishing the electrical work, confirm that each electrical component and terminal inside the electrical components box is connected securely.
- Make sure all covers are closed before starting up the unit.



**NOTICE**

Only applicable if the power supply is three-phase, and the compressor has an ON/OFF starting method.

If there exists the possibility of reversed phase after a momentary black out and the power goes on and off while the product is operating, attach a reversed phase protection circuit locally. Running the product in reversed phase can break the compressor and other parts.

2 About the documentation

2.1 About this document

Target audience

Authorised installers



**INFORMATION**

This appliance is intended to be used by expert or trained users in shops, in light industry and on farms, or for commercial use by lay persons.

Documentation set

This document is part of a documentation set. The complete set consists of:

Document	Contains...	Format
General safety precautions	Safety instructions that you must read before installing	Paper (in the box of the outdoor unit)
Outdoor unit installation manual	Installation instructions	
Installer reference guide	Preparation of the installation, technical specifications, reference data,...	Digital files on <a href="http://www.daikineurope.com/support-and-manuals/product-information/">http://www.daikineurope.com/support-and-manuals/product-information/</a> .

Latest revisions of the supplied documentation may be available on the regional Daikin website or via your dealer.

2.2 Installer reference guide at a glance

Chapter	Description
General safety precautions	Safety instructions that you must read before installing
About the documentation	What documentation exists for the installer
About the box	How to unpack the units and remove their accessories
About the units and options	<ul style="list-style-type: none"> <li>▪ How to identify the units</li> <li>▪ Possible combinations of units and options</li> </ul>
Preparation	What to do and know before going on-site
Installation	What to do and know to install the system
Commissioning	What to do and know to commission the system after it is installed
Hand-over to the user	What to give and explain to the user
Maintenance and service	How to maintain and service the units
Troubleshooting	What to do in case of problems
Disposal	How to dispose of the system
Technical data	Specifications of the system
Glossary	Definition of terms

## 3 About the box

### 3 About the box

#### 3.1 Overview: About the box

This chapter describes what you have to do after the box with the outdoor unit is delivered on-site.

It contains information about:

- Unpacking and handling the units
- Removing the accessories from the units

Keep the following in mind:

- At delivery, the unit must be checked for damage. Any damage must be reported immediately to the carrier's claims agent.
- Bring the packed unit as close as possible to its final installation position to prevent damage during transport.

#### 3.2 Outdoor unit

##### 3.2.1 To unpack the outdoor unit

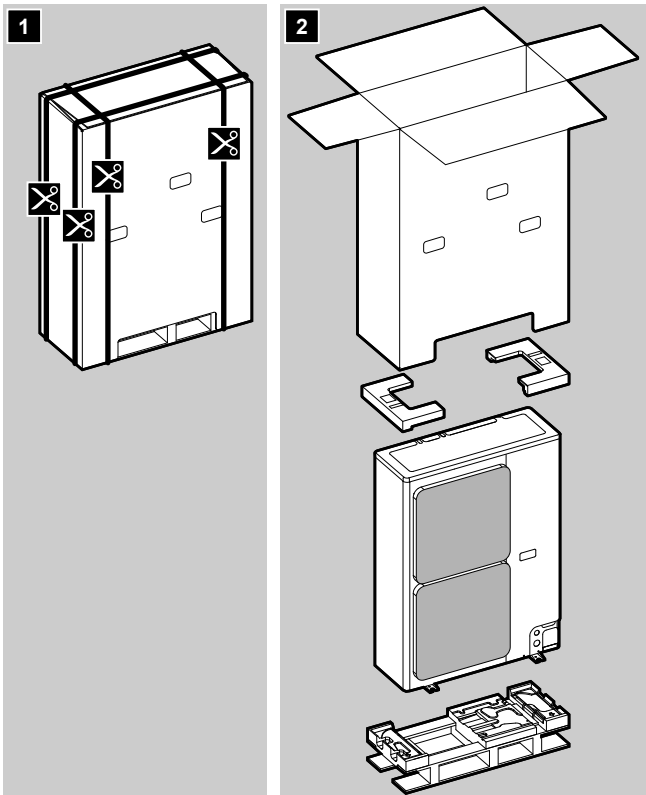

##### 3.2.2 To handle the outdoor unit

Carry the unit slowly as shown:

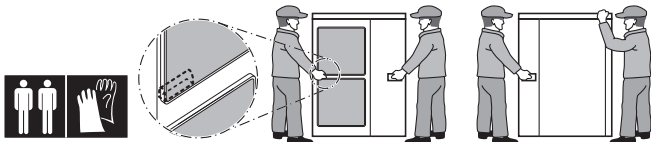

#### CAUTION

To avoid injury, do NOT touch the air inlet or aluminum fins of the unit.

##### 3.2.3 To remove the accessories from the outdoor unit

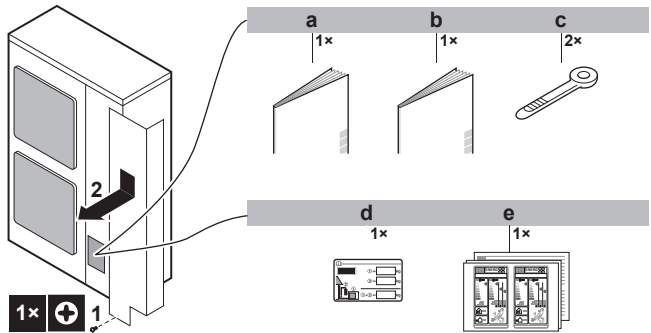

- a General safety precautions
- b Outdoor unit installation manual
- c Cable tie
- d Fluorinated greenhouse gases label
- e Energy label

## 4 About the units and options

### 4.1 Overview: About the units and options

This chapter contains information about:

- Identifying the outdoor unit
- Combining the outdoor unit with options

#### 4.2 Identification



#### NOTICE

When installing or servicing several units at the same time, make sure NOT to switch the service panels between different models.

##### 4.2.1 Identification label: Outdoor unit

Location

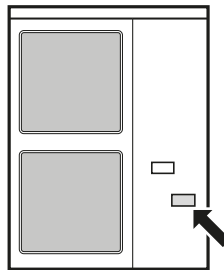

## 4.3 Combining units and options

### 4.3.1 Possible options for the outdoor unit

#### Demand adaptor kit

Can be used for the following:

- Low noise: To lower the operation sound of the outdoor unit.
- I-demand function: To limit the power consumption from the system (example: budget control, limit power consumption during peak moments...).

Model	Demand adaptor kit
AZQS_Y1	KRP58M51
AZQS_V1	KRP58M51MK

For installation instructions, see the installation manual of the demand adaptor kit.

## 5 Preparation

### 5.1 Overview: Preparation

This chapter describes what you have to do and know before going on-site.

It contains information about:

- Preparing the installation site
- Preparing the refrigerant piping
- Preparing the electrical wiring

### 5.2 Preparing installation site

Do NOT install the unit in places often used as work place. In case of construction works (e.g. grinding works) where a lot of dust is created, the unit must be covered.

Choose the installation location with sufficient place for carrying the unit in and out of the site.

#### 5.2.1 Installation site requirements of the outdoor unit



#### INFORMATION

Also read the following requirements:

- General installation site requirements. See the "General safety precautions" chapter.
- Service space requirements. See the "Technical data" chapter.
- Refrigerant piping requirements (length, height difference). See further in this "Preparation" chapter.

Mind the following:

- Select a place where rain can be avoided as much as possible.
- Take care that in the event of a water leak, water cannot cause any damage to the installation space and surroundings.
- Choose a location where the hot/cold air discharged from the unit or the operation noise, will NOT disturb anyone.
- Heat exchanger fins are sharp and injury is possible. Choose an installation location where there is no risk for injury (especially in areas where children play).

Do NOT install the unit in the following places:

- Sound sensitive areas (e.g. near a bedroom and the like), so that the operation noise will cause no trouble.  
Note: If the sound is measured under actual installation conditions, the measured value might be higher than the sound pressure level mentioned in Sound spectrum in the data book due to environmental noise and sound reflections.



#### INFORMATION

The sound pressure level is less than 70 dB(A).

- In places where a mineral oil mist, spray or vapour may be present in the atmosphere. Plastic parts may deteriorate and fall off or cause water leakage.

It is NOT recommended to install the unit in the following places because it may shorten the life of the unit:

- in coastal areas or other places where the air contains high levels of salt. Corrosion may occur,
- where the voltage fluctuates a lot,
- in vehicles or vessels,
- where acidic or alkaline vapour is present.

When the outdoor unit is subject to windy and/or low ambient temperatures, mind the following guidelines:

Strong winds ( $\geq 18$  km/h) blowing against the outdoor unit's air outlet causes short circuit (suction of discharge air). This may result in:

- deterioration of the operational capacity;
- frequent frost acceleration in heating operation;
- disruption of operation due to decrease of low pressure or increase of high pressure;
- a broken fan (if a strong wind blows continuously on the fan, it may start rotating very fast, until it breaks).

It is recommended to install a baffle plate when the air outlet is exposed to wind.

It is recommended to install the outdoor unit with the air inlet facing the wall and NOT directly exposed to the wind.

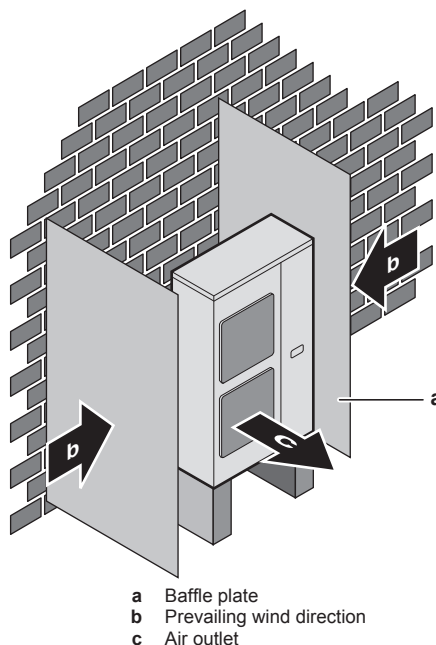

## 5 Preparation

### 5.2.2 Additional installation site requirements of the outdoor unit in cold climates

Protect the outdoor unit against direct snowfall and take care that the outdoor unit is NEVER snowed up.

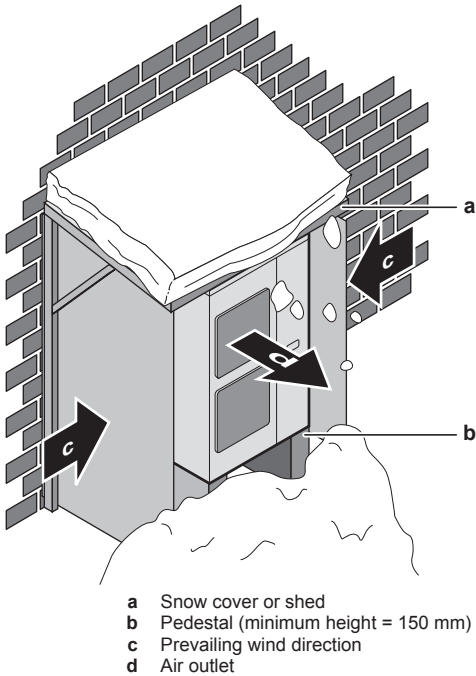

### 5.3 Preparing refrigerant piping

#### 5.3.1 Refrigerant piping requirements



#### INFORMATION

Also read the precautions and requirements in the "General safety precautions" chapter.

#### Refrigerant piping material

- **Piping material:** Phosphoric acid deoxidised seamless copper.
- **Piping temper grade and thickness:**

Outer diameter (Ø)	Temper grade	Thickness (t) <sup>(a)</sup>	
6.4 mm (1/4")	Annealed	≥0.8 mm	
9.5 mm (3/8")			
12.7 mm (1/2")			
15.9 mm (5/8")	Annealed	≥1.0 mm	
19.1 mm (3/4")	Half hard		

(a) Depending on the applicable legislation and the unit's maximum working pressure (see "PS High" on the unit name plate), larger piping thickness might be required.

- **Flare connections:** Only use annealed material.

#### Refrigerant piping diameter

Use the same diameters as the connections on the outdoor units:

L1 liquid piping	Ø9.5 mm
L1 gas piping	Ø15.9 mm

### Refrigerant piping length and height difference

The piping length and height difference must comply with the following requirements:

	Total one-way piping length: 5 m ≤ L1 ≤ 50 m (70 m) <sup>(a)</sup>
	Height difference between the highest indoor unit and the outdoor unit: H1 ≤ 30 m

(a) Parenthesised figure represents the equivalent length.

### 5.3.2 Refrigerant piping insulation

- Use polyethylene foam as insulation material:
  - with a heat transfer rate between 0.041 and 0.052 W/mK (0.035 and 0.045 kcal/mh°C)
  - with a heat resistance of at least 120°C
- Insulation thickness

Ambient temperature	Humidity	Minimum thickness
≤30°C	75% to 80% RH	15 mm
>30°C	≥80% RH	20 mm

### 5.4 Preparing electrical wiring

#### 5.4.1 About preparing electrical wiring



#### INFORMATION

Also read the precautions and requirements in the "General safety precautions" chapter.



#### INFORMATION

Also read "6.7.5 Specifications of standard wiring components" on page 18.



#### WARNING

- If the power supply has a missing or wrong N-phase, equipment might break down.
- Establish proper earthing. Do NOT earth the unit to a utility pipe, surge absorber, or telephone earth. Incomplete earthing may cause electrical shock.
- Install the required fuses or circuit breakers.
- Secure the electrical wiring with cable ties so that the cables do NOT come in contact with sharp edges or piping, particularly on the high-pressure side.
- Do NOT use taped wires, stranded conductor wires, extension cords, or connections from a star system. They can cause overheating, electrical shock or fire.
- Do NOT install a phase advancing capacitor, because this unit is equipped with an inverter. A phase advancing capacitor will reduce performance and may cause accidents.



#### WARNING

- All wiring must be performed by an authorized electrician and must comply with the applicable legislation.
- Make electrical connections to the fixed wiring.
- All components procured on the site and all electrical construction must comply with the applicable legislation.



#### WARNING

ALWAYS use multicore cable for power supply cables.



## 6 Installation

### 6.1 Overview: Installation

This chapter describes what you have to do and know on-site to install the system.

#### Typical workflow

Installation typically consists of the following stages:

- Mounting the outdoor unit.
- Mounting the indoor units.
- Connecting the refrigerant piping.
- Checking the refrigerant piping.
- Charging refrigerant.
- Connecting the electrical wiring.
- Finishing the outdoor installation.
- Finishing the indoor installation.



#### INFORMATION

For installation of the indoor unit (mounting the indoor unit, connecting the refrigerant piping to the indoor unit, connecting the electrical wiring to the indoor unit ...), see the installation manual of the indoor unit.

### 6.2 Opening the units

#### 6.2.1 About opening the units

At certain times, you have to open the unit. **Example:**

- When connecting the refrigerant piping
- When connecting the electrical wiring
- When maintaining or servicing the unit



#### DANGER: RISK OF ELECTROCUTION

Do NOT leave the unit unattended when the service cover is removed.

#### 6.2.2 To open the outdoor unit

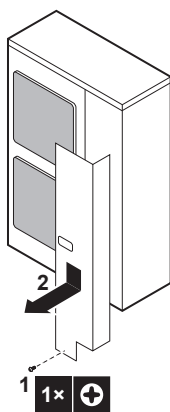

### 6.3 Mounting the outdoor unit

#### 6.3.1 About mounting the outdoor unit

##### Typical workflow

Mounting the outdoor unit typically consists of the following stages:

- 1 Providing the installation structure.
- 2 Installing the outdoor unit.
- 3 Providing drainage.
- 4 Preventing the outdoor unit from falling over.
- 5 Protecting the unit against snow and wind by installing a snow cover and baffle plates. See "Preparing installation site" in "5 Preparation" on page 7.

#### 6.3.2 Precautions when mounting the outdoor unit



#### INFORMATION

Also read the precautions and requirements in the following chapters:

- General safety precautions
- Preparation

#### 6.3.3 To provide the installation structure

Check the strength and level of the installation ground so that the unit will not cause any operating vibration or noise.

Fix the unit securely by means of foundation bolts in accordance with the foundation drawing.

Prepare 4 sets of anchor bolts, nuts and washers (field supply) as follows:

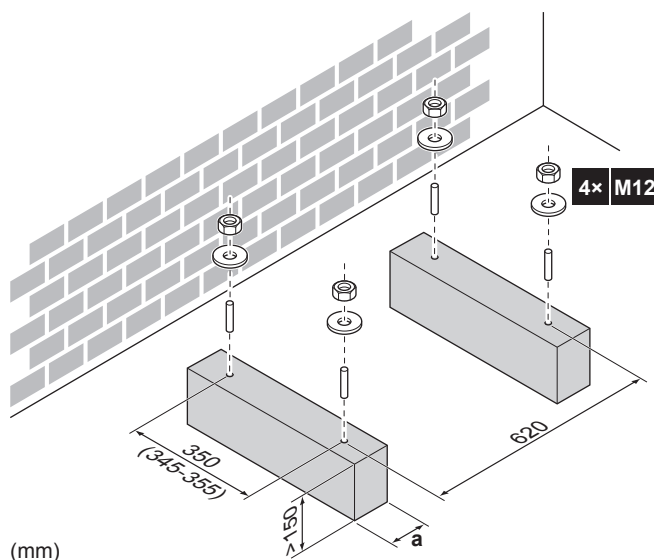

(mm)

a Make sure not to cover the drain holes.



#### INFORMATION

The recommended height of the upper protruding part of the bolts is 20 mm.

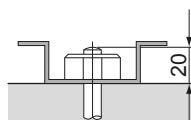

## 6 Installation



### NOTICE

Fix the outdoor unit to the foundation bolts using nuts with resin washers (a). If the coating on the fastening area is stripped off, the nuts rust easily.



### 6.3.4 To install the outdoor unit

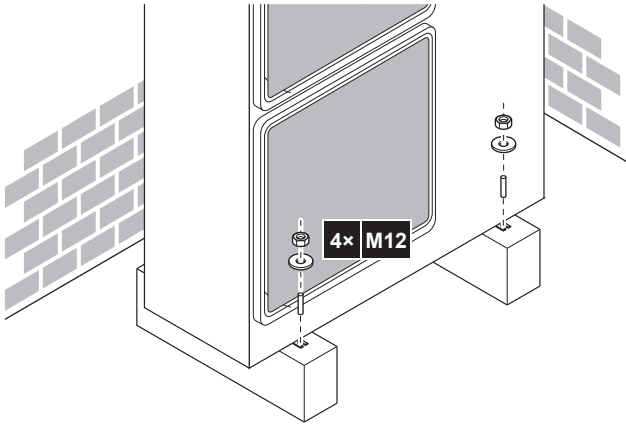

### 6.3.5 To provide drainage

- Make sure that condensation water can be evacuated properly.
- Install the unit on a base to make sure that there is a proper drainage in order to avoid ice accumulation.
- Prepare a water drainage channel around the foundation to drain waste water surrounding the unit.
- Avoid drain water flowing over the footpath, so that it does not become slippery in case of ambient freezing temperatures.
- If you install the unit on a frame, install a waterproof plate within 150 mm of the underside of the unit in order to prevent the invasion of water in the unit and to avoid the drain water dripping (see the following illustration).

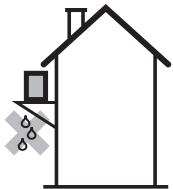

### INFORMATION

If necessary, you can use a drain plug kit (field supply) to prevent drain water from dripping.



### NOTICE

If drain holes of the outdoor unit are covered by a mounting base or by floor surface, raise the unit to provide a free space of more than 150 mm under the outdoor unit.

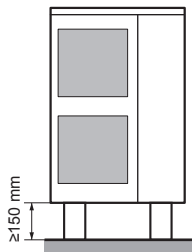

### Drain holes (dimensions in mm)

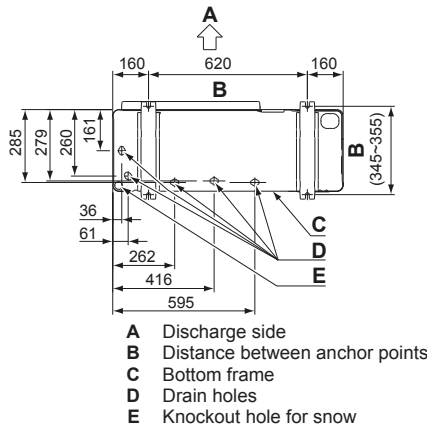

- A Discharge side
- B Distance between anchor points
- C Bottom frame
- D Drain holes
- E Knockout hole for snow

### Snow

In regions with snowfall, snow might build up and freeze between the heat exchanger and the external plate. This might decrease the operating efficiency. To prevent this:

- 1 Drill (a, 4×) and remove the knockout hole (b).

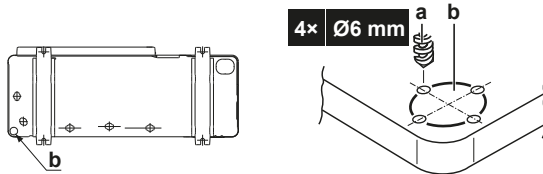

- 2 Remove the burrs, and paint the edges and areas around the edges using repair paint to prevent rusting.

### 6.3.6 To prevent the outdoor unit from falling over

In case the unit is installed in places where strong wind can tilt the unit, take following measure:

Connect cables (field supply) as shown:

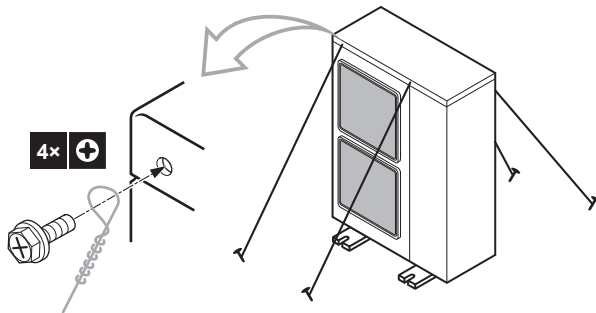

## 6.4 Connecting the refrigerant piping

### 6.4.1 About connecting the refrigerant piping

#### Before connecting the refrigerant piping

Make sure the outdoor and indoor unit are mounted.

#### Typical workflow

Connecting the refrigerant piping involves:

- Connecting the refrigerant piping to the outdoor unit
- Connecting the refrigerant piping to the indoor unit
- Installing oil traps
- Insulating the refrigerant piping

- Keeping in mind the guidelines for:
  - Pipe bending
  - Flaring pipe ends
  - Brazing
  - Using the stop valves

### 6.4.2 Precautions when connecting the refrigerant piping



**INFORMATION**

Also read the precautions and requirements in the following chapters:

- General safety precautions
- Preparation



**DANGER: RISK OF BURNING**



**CAUTION**

- Do NOT use mineral oil on flared part.
- NEVER install a drier to this R410A unit to guarantee its lifetime. The drying material may dissolve and damage the system.



**NOTICE**

Take the following precautions on refrigerant piping into account:

- Avoid anything but the designated refrigerant to get mixed into the refrigerant cycle (e.g. air).
- Only use R410A when adding refrigerant.
- Only use installation tools (e.g. manifold gauge set) that are exclusively used for R410A installations to withstand the pressure and to prevent foreign materials (e.g. mineral oils and moisture) from mixing into the system.
- Install the piping so that the flare is NOT subjected to mechanical stress
- Protect the piping as described in the following table to prevent dirt, liquid or dust from entering the piping.
- Use caution when passing copper tubes through walls (see figure below).

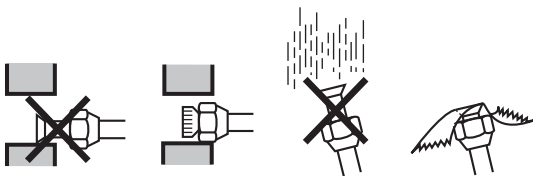

Unit	Installation period	Protection method
Outdoor unit	>1 month	Pinch the pipe
	<1 month	Pinch or tape the pipe
Indoor unit	Regardless of the period	



**INFORMATION**

Do NOT open the refrigerant stop valve before checking the refrigerant piping. When you need to charge additional refrigerant it is recommended to open the refrigerant stop valve after charging.

### 6.4.3 Guidelines when connecting the refrigerant piping

Take the following guidelines into account when connecting pipes:

- Coat the flare inner surface with ether oil or ester oil when connecting a flare nut. Tighten 3 or 4 turns by hand, before tightening firmly.

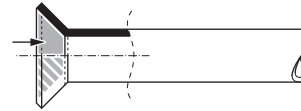

- Always use two wrenches together when loosening a flare nut.
- Always use a spanner and torque wrench together to tighten the flare nut when connecting the piping. This to prevent nut cracking and leaks.

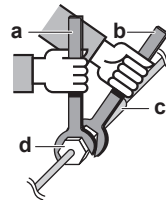

- a Torque wrench
- b Spanner
- c Piping union
- d Flare nut

Piping size (mm)	Tightening torque (N•m)	Flare dimensions (A) (mm)	Flare shape (mm)
Ø6.4	15~17	8.7~9.1	
Ø9.5	33~39	12.8~13.2	
Ø12.7	50~60	16.2~16.6	
Ø15.9	63~75	19.3~19.7	
Ø19.1	90~110	23.6~24.0	

### 6.4.4 Pipe bending guidelines

Use a pipe bender for bending. All pipe bends should be as gentle as possible (bending radius should be 30~40 mm or larger).

### 6.4.5 To flare the pipe end



**CAUTION**

- Incomplete flaring may cause refrigerant gas leakage.
- Do NOT re-use flares. Use new flares to prevent refrigerant gas leakage.
- Use flare nuts that are included with the unit. Using different flare nuts may cause refrigerant gas leakage.

- 1 Cut the pipe end with a pipe cutter.
- 2 Remove burrs with the cut surface facing downward so that the chips do not enter the pipe.

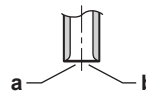

- a Cut exactly at right angles.
- b Remove burrs.

- 3 Remove the flare nut from the stop valve and put the flare nut on the pipe.
- 4 Flare the pipe. Set exactly at the position as shown in the following illustration.

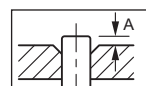

## 6 Installation

	Flare tool for R410A (clutch type)	Conventional flare tool	
		Clutch type (Ridgid-type)	Wing nut type (Imperial-type)
A	0~0.5 mm	1.0~1.5 mm	1.5~2.0 mm

5 Check that the flaring is properly made.

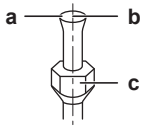

- a Flare's inner surface must be flawless.
- b The pipe end must be evenly flared in a perfect circle.
- c Make sure the flare nut is lifted.

### 6.4.6 To braze the pipe end

The indoor unit and outdoor unit have flare connections. Connect both ends without brazing. If brazing should be needed, take the following into account:

- When brazing, blow through with nitrogen to prevent creation of large quantities of oxidised film on the inside of the piping. This film adversely affects valves and compressors in the refrigerating system and prevents proper operation.
- Set the nitrogen pressure to 20 kPa (just enough so it can be felt on the skin) with a pressure-reducing valve.

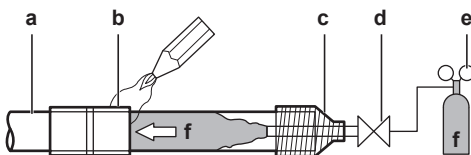

- a Refrigerant piping
- b Part to be brazed
- c Taping
- d Manual valve
- e Pressure-reducing valve
- f Nitrogen

- Do NOT use anti-oxidants when brazing pipe joints. Residue can clog pipes and break equipment.
- Do NOT use flux when brazing copper-to-copper refrigerant piping. Use phosphor copper brazing filler alloy (BCuP), which does not require flux. Flux has an extremely harmful influence on refrigerant piping systems. For instance, if chlorine based flux is used, it will cause pipe corrosion or, in particular, if the flux contains fluorine, it will deteriorate the refrigerant oil.

### 6.4.7 Using the stop valve and service port

#### To handle the stop valve

Take the following guidelines into account:

- The stop valves are factory closed.
- The following illustration shows each part required in handling the valve.

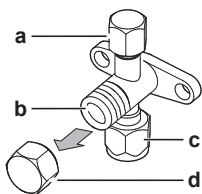

- a Service port and service port cap
- b Valve stem
- c Field piping connection
- d Stem cap

- Keep both stop valves open during operation.

- Do NOT apply excessive force to the valve stem. Doing so may break the valve body.
- Always make sure to secure the stop valve with a spanner, then loosen or tighten the flare nut with a torque wrench. Do NOT place the spanner on the stem cap, as this could cause a refrigerant leak.

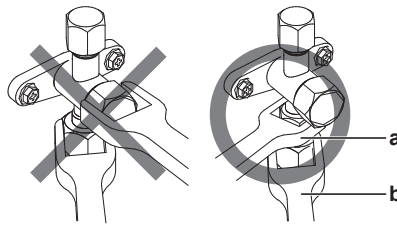

- a Spanner
- b Torque wrench

- When it is expected that the operating pressure will be low (e.g. when cooling will be performed while the outside air temperature is low), sufficiently seal the flare nut in the stop valve on the gas line with silicon sealant to prevent freezing.

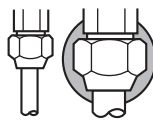

■ Silicon sealant, make sure there is no gap.

#### To open/close the stop valve

- 1 Remove the valve cover.
- 2 Insert a hexagon wrench (liquid side: 4 mm, gas side: 6 mm) into the valve stem and turn the valve stem:

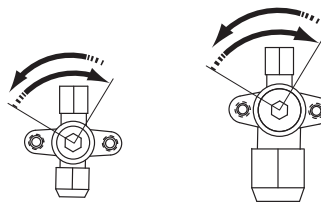

Counterclockwise to open.  
Clockwise to close.

- 3 When the valve stem cannot be turned any further, stop turning. The valve is now opened/closed.

#### To handle the stem cap

Take the following guidelines into account:

- The stem cap is sealed where indicated with the arrow. Do NOT damage it.

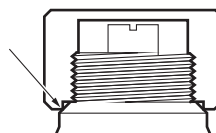

- After handling the stop valve, make sure to tighten the stem cap securely.
- For the tightening torque, refer to the following table.
- Check for refrigerant leaks after tightening the stem cap.

Item	Tightening torque (N·m)
Stem cap, liquid side	13.5~16.5
Stem cap, gas side	22.5~27.5
Service port cap	11.5~13.9

## To handle the service cap

Take the following guidelines into account:

- Always use a charge hose equipped with a valve depressor pin, since the service port is a Schrader type valve.
- After handling the service port, tighten the service port cap securely. For the tightening torque, refer to the table in chapter "To handle the stem cap" on page 12.
- Check for refrigerant leaks after tightening the service port cap.

## 6.4.8 To connect the refrigerant piping to the outdoor unit

1 Do the following:

- Remove the service cover (a) with screw (b).
- Remove the piping intake plate (c) with screw (d).

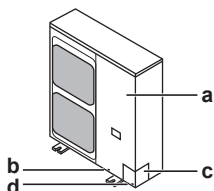

2 Choose a piping route (a, b, c or d).

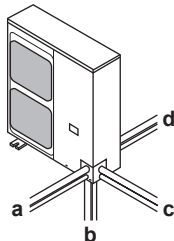

3 If you have chosen the downwards piping route:

- Drill (a, 4×) and remove the knockout hole (b).
- Cut out the slits (c) with a metal saw.

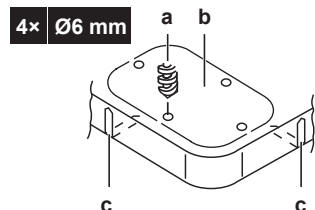

4 Do the following:

- Connect the liquid pipe (a) to the liquid stop valve.
- Connect the gas pipe (b) to the gas stop valve.

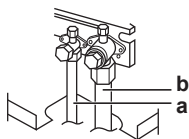

5 Do the following:

- Insulate the liquid piping (a) and the gas piping (b).
- Wind heat insulation around the curves, and then cover it with vinyl tape (c).
- Make sure the field piping does not touch any compressor components (d).
- Seal the insulation ends (sealant etc.) (e).

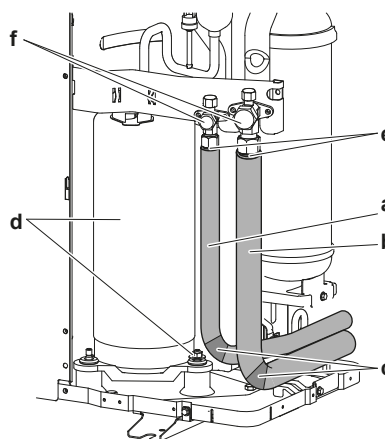

6 If the outdoor unit is installed above the indoor unit, cover the stop valves (f, see above) with sealing material to prevent condensed water on the stop valves from moving to the indoor unit.



### NOTICE

Any exposed piping might cause condensation.

7 Reattach the service cover and the piping intake plate.

8 Seal all gaps (example: a) to prevent snow and small animals from entering the system.

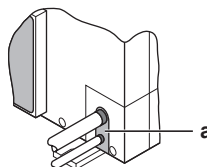

### WARNING

Provide adequate measures to prevent that the unit can be used as a shelter by small animals. Small animals that make contact with electrical parts can cause malfunctions, smoke or fire.



### NOTICE

Precautions when making knockout holes:

- Avoid damaging the casing.
- After making the knockout holes, we recommend you remove the burrs and paint the edges and areas around the edges using repair paint to prevent rusting.
- When passing electrical wiring through the knockout holes, wrap the wiring with protective tape to prevent damage.

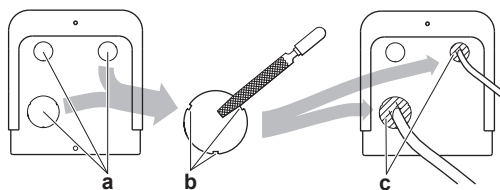

- a Knockout hole
- b Burr
- c Sealant etc.



### NOTICE

Make sure to open the stop valves after installing the refrigerant piping and performing vacuum drying. Running the system with the stop valves closed may break the compressor.

## 6 Installation

### 6.4.9 To determine if oil traps are required

If oil flows back into the outdoor unit's compressor, this might cause liquid compression or deterioration of oil return. Oil traps in the rising gas piping can prevent this.

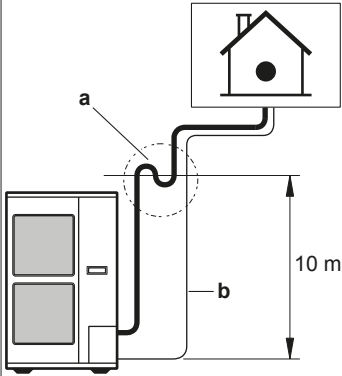
If	Then
The indoor unit is installed higher than the outdoor unit	Install an oil trap every 10 m (height difference).  a Rising gas piping with oil trap b Liquid piping
The outdoor unit is installed higher than the indoor unit	Oil traps are NOT required.

## 6.5 Checking the refrigerant piping

### 6.5.1 About checking the refrigerant piping

The outdoor unit's **internal** refrigerant piping has been factory tested for leaks. You only have to check the outdoor unit's **external** refrigerant piping.

#### Before checking the refrigerant piping

Make sure the refrigerant piping is connected between the outdoor unit and the indoor unit.

#### Typical workflow

Checking the refrigerant piping typically consists of the following stages:

- 1 Checking for leaks in the refrigerant piping.
- 2 Performing vacuum drying to remove all moisture, air or nitrogen from the refrigerant piping.

If there is a possibility of moisture being present in the refrigerant piping (for example, rainwater may have entered the piping), first carry out the vacuum drying procedure below until all moisture has been removed.

### 6.5.2 Precautions when checking the refrigerant piping



#### INFORMATION

Also read the precautions and requirements in the following chapters:

- General safety precautions
- Preparation



#### NOTICE

Use a 2-stage vacuum pump with a non-return valve that can evacuate to a gauge pressure of  $-100.7$  kPa (5 Torr absolute). Make sure the pump oil does not flow oppositely into the system while the pump is not working.



#### NOTICE

Use this vacuum pump for R410A exclusively. Using the same pump for other refrigerants may damage the pump and the unit.



#### NOTICE

- Connect the vacuum pump to **both** the service port of the gas stop valve and the service port of the liquid stop valve to increase efficiency.
- Make sure that the gas stop valve and liquid stop valve are firmly closed before performing the leak test or vacuum drying.

### 6.5.3 Checking refrigerant piping: Setup

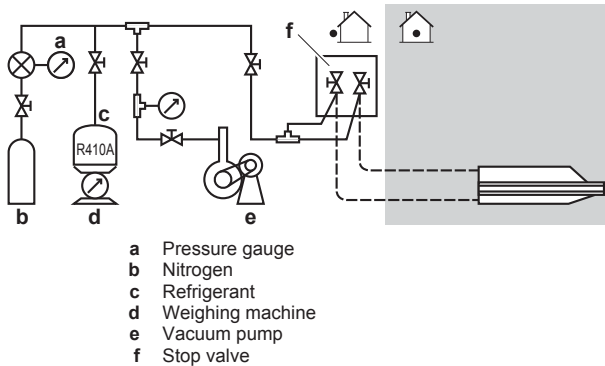

### 6.5.4 To check for leaks



#### NOTICE

Do NOT exceed the unit's maximum working pressure (see "PS High" on the unit name plate).



#### NOTICE

Make sure to use a recommended bubble test solution from your wholesaler. Do not use soap water, which may cause cracking of flare nuts (soap water may contain salt, which absorbs moisture that will freeze when the piping gets cold), and/or lead to corrosion of flared joints (soap water may contain ammonia which causes a corrosive effect between the brass flare nut and the copper flare).

- 1 Charge the system with nitrogen gas up to a gauge pressure of at least 200 kPa (2 bar). It is recommended to pressurize to 3000 kPa (30 bar) in order to detect small leaks.
- 2 Check for leaks by applying the bubble test solution to all connections.
- 3 Discharge all nitrogen gas.



#### INFORMATION

After opening the stop valve, it is possible that the pressure in the refrigerant piping does NOT increase. This might be caused by e.g. the closed state of the expansion valve in the outdoor unit circuit, but does NOT present any problem for correct operation of the unit.

### 6.5.5 To perform vacuum drying

- 1 Vacuum the system until the pressure on the manifold indicates  $-0.1$  MPa ( $-1$  bar).
- 2 Leave as is for 4-5 minutes and check the pressure:

If the pressure...	Then...
Does not change	There is no moisture in the system. This procedure is finished.
Increases	There is moisture in the system. Go to the next step.

- 3 Evacuate for at least 2 hours to a pressure on the manifold of  $-0.1$  MPa ( $-1$  bar).
- 4 After turning OFF the pump, check the pressure for at least 1 hour.
- 5 If you do NOT reach the target vacuum or cannot maintain the vacuum for 1 hour, do the following:
  - Check for leaks again.
  - Perform vacuum drying again.



#### NOTICE

Make sure to open the stop valves after installing the refrigerant piping and performing vacuum drying. Running the system with the stop valves closed may break the compressor.

## 6.6 Charging refrigerant

### 6.6.1 About charging refrigerant

The outdoor unit is factory charged with refrigerant, but in some cases the following might be necessary:

What	When
Charging additional refrigerant	When the total liquid piping length is more than specified (see later).
Completely recharging refrigerant	<b>Example:</b> <ul style="list-style-type: none"> <li>▪ When relocating the system.</li> <li>▪ After a leak.</li> </ul>

#### Charging additional refrigerant

Before charging additional refrigerant, make sure the outdoor unit's **external** refrigerant piping is checked (leak test, vacuum drying).



#### INFORMATION

Depending on the units and/or the installation conditions, it might be necessary to connect electrical wiring before you can charge refrigerant.

Typical workflow – Charging additional refrigerant typically consists of the following stages:

- 1 Determining if and how much you have to charge additionally.
- 2 If necessary, charging additional refrigerant.
- 3 Filling in the fluorinated greenhouse gases label, and fixing it to the inside of the outdoor unit.

### Completely recharging refrigerant

Before completely recharging refrigerant, make sure the following is done:

- 1 The system is pumped down.
- 2 The outdoor unit's **external** refrigerant piping is checked (leak test, vacuum drying).
- 3 Vacuum drying on the outdoor unit's **internal** refrigerant piping is performed.



#### NOTICE

Before completely recharging, perform vacuum drying on the outdoor unit's **internal** refrigerant piping as well. To do so, use the internal service port of the outdoor unit (between the heat exchanger and the 4-way valve). Do NOT use the service ports of the stop valves, because vacuum drying cannot be performed properly from these ports.



#### WARNING

Some sections of the refrigerant circuit may be isolated from other sections caused by components with specific functions (e.g. valves). The refrigerant circuit therefore features additional service ports for vacuuming, pressure relief or pressurizing the circuit.

In case it is required to perform **brazing** on the unit, ensure that there is no pressure remaining inside the unit. Internal pressures need to be released with ALL the service ports indicated on the figures below opened. The location is depending on model type.

## 6 Installation

Location of service ports:

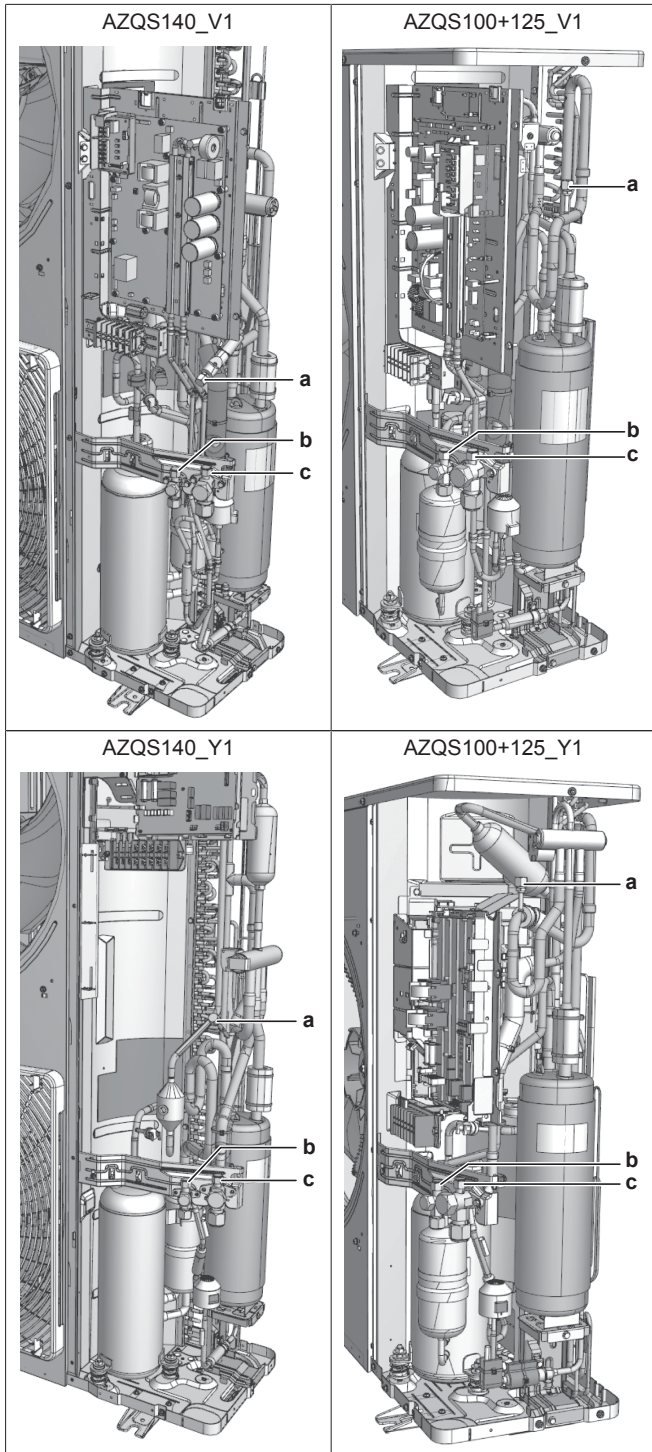

- a Internal service port
- b Stop valve with service port (liquid)
- c Stop valve with service port (gas)

Typical workflow – Completely recharging refrigerant typically consists of the following stages:

- 1 Determining how much refrigerant to charge.
- 2 Charging refrigerant.
- 3 Filling in the fluorinated greenhouse gases label, and fixing it to the inside of the outdoor unit.

### 6.6.2 Precautions when charging refrigerant

#### **i** INFORMATION

Also read the precautions and requirements in the following chapters:

- General safety precautions
- Preparation

### 6.6.3 To determine the additional refrigerant amount

To determine if adding additional refrigerant is necessary

If	Then
$L1 \leq 30$ m (chargeless length)	You do not have to add additional refrigerant.
$L1 > 30$ m	You must add additional refrigerant. For future servicing, encircle the selected amount in the tables below.

#### **i** INFORMATION

Piping length is the one way length of liquid piping.

To determine the additional refrigerant amount (R in kg)

	30~40 m	40~50 m
R:	0.5 kg	1.0 kg

### 6.6.4 To determine the complete recharge amount

Model					
	5~10	10~20	20~30	30~40	40~50
AZQS100+125	1.9	2.4	2.9	3.4	3.9
AZQS140	3.0	3.5	4.0	4.5	5.0

### 6.6.5 Charging refrigerant: Setup

See "6.5.3 Checking refrigerant piping: Setup" on page 14.

### 6.6.6 To charge refrigerant

#### **!** WARNING

- Only use R410A as refrigerant. Other substances may cause explosions and accidents.
- R410A contains fluorinated greenhouse gases covered by the Kyoto Protocol. Its global warming potential value is 1975. Do NOT vent these gases into the atmosphere.
- When charging refrigerant, always use protective gloves and safety glasses.



**CAUTION**

To avoid compressor breakdown, do NOT charge more than the specified amount of refrigerant.

**Prerequisite:** Before charging refrigerant, make sure the refrigerant piping is connected and checked (leak test and vacuum drying).

- 1 Connect the refrigerant cylinder to both the service port of the gas stop valve and the service port of the liquid stop valve.
- 2 Charge the additional refrigerant amount.
- 3 Open the stop valves.

If pump down is needed in case of dismantling or relocating the system, see "11.3 To pump down" on page 22 for more details.

### 6.6.7 To fix the fluorinated greenhouse gases label

- 1 Fill in the label as follows:

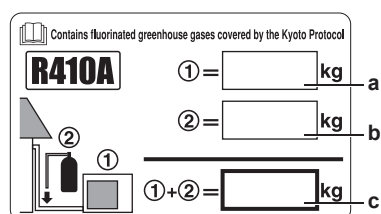

- a Factory refrigerant charge: see unit name plate  
b Additional refrigerant amount charged  
c Total refrigerant charge

- 2 The filled out label must be adhered on the inside of the product and in the proximity of the product charging port (e.g., on the inside of the service cover).

## 6.7 Connecting the electrical wiring

### 6.7.1 About connecting the electrical wiring

#### Typical workflow

Connecting the electrical wiring typically consists of the following stages:

- 1 Making sure the power supply system complies with the electrical specifications of the units.
- 2 Connecting the electrical wiring to the outdoor unit.
- 3 Connecting the electrical wiring to the indoor units.
- 4 Connecting the main power supply.

### 6.7.2 About electrical compliance

#### AZQS\_V1 + AZQS125\_Y1

Equipment complying with EN/IEC 61000-3-12 (European/International Technical Standard setting the limits for harmonic currents produced by equipment connected to public low-voltage systems with input current >16 A and ≤75 A per phase.).

#### AZQS140\_Y1

Equipment complying with:

- EN/IEC 61000-3-12 provided that the short-circuit power  $S_{sc}$  is greater than or equal to the minimum  $S_{sc}$  value at the interface point between the user's supply and the public system.
- EN/IEC 61000-3-12 = European/International Technical Standard setting the limits for harmonic currents produced by equipment connected to public low-voltage systems with input current >16 A and ≤75 A per phase.
- It is the responsibility of the installer or user of the equipment to ensure, by consultation with the distribution network operator if necessary, that the equipment is connected only to a supply with a short-circuit power  $S_{sc}$  greater than or equal to the minimum  $S_{sc}$  value.

Model	Minimum $S_{sc}$ value
AZQS140_Y1	1170 kVA <sup>(a)</sup>

- (a) This is the most stringent value. For specific product data, see the databooks.

### 6.7.3 Precautions when connecting the electrical wiring

**INFORMATION**

Also read the precautions and requirements in the following chapters:

- General safety precautions
- Preparation

**DANGER: RISK OF ELECTROCUTION****INFORMATION**

More information about the legend and the location of the wiring diagram of the unit can be found in "12.5 Wiring diagram" on page 30.

**WARNING**

ALWAYS use multicore cable for power supply cables.

**CAUTION**

For use of units in applications with temperature alarm settings it is recommended to foresee a delay of 10 minutes for signalling the alarm in case the alarm temperature is exceeded. The unit may stop for several minutes during normal operation for "defrosting the unit", or when in "thermostat stop" operation.

### 6.7.4 Guidelines when connecting the electrical wiring

Keep the following in mind:

- If stranded conductor wires are being used, install a round crimp-style terminal on the tip. Place the round crimp-style terminal on the wire up to the covered part and fasten the terminal with the appropriate tool.

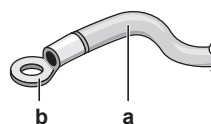

- a Stranded conductor wire  
b Round crimp-style terminal

- Use the following methods for installing wires:

## 6 Installation

Wire type	Installation method
Single core wire	<p>a Curled single core wire b Screw c Flat washer</p>
Stranded conductor wire with round crimp-style terminal	<p>a Terminal b Screw c Flat washer</p>



### NOTICE

Precautions when laying power wiring:

- Do not connect wiring of different thicknesses to the power terminal block (slack in the power wiring may cause abnormal heat).
- When connecting wiring which is the same thickness, do as shown in the figure below.



- For wiring, use the designated power wire and connect firmly, then secure to prevent outside pressure being exerted on the terminal board.
- Use an appropriate screwdriver for tightening the terminal screws. A screwdriver with a small head will damage the head and make proper tightening impossible.
- Over-tightening the terminal screws may break them.

### Tightening torques

Item	Tightening torque (N·m)
M4 (X1M)	1.2~1.8
M4 (earth)	1.2~1.4
M5 (X1M)	2.0~3.0
M5 (earth)	2.4~2.9

### 6.7.5 Specifications of standard wiring components

Component		AZQS_V1			AZQS_Y1		
		100	125	140	100	125	140
Power supply cable	MCA <sup>(a)</sup>	29.5 A	31.5 A	32.8 A	15.2 A	17.2 A	21.8 A
	Voltage	230 V			400 V		
	Phase	1~			3N~		
	Frequency	50 Hz					
	Wire sizes	Must comply with applicable legislation					
Interconnection cables	Minimum cable section of 2.5 mm <sup>2</sup> and applicable for 230 V						
Recommended field fuse		32 A	40 A	16 A	20 A	25 A	
Earth leakage circuit breaker	Must comply with applicable legislation						

(a) MCA=Minimum circuit ampacity. Stated values are maximum values (see electrical data of combination with indoor units for exact values).

### 6.7.6 To connect the electrical wiring on the outdoor unit



#### NOTICE

- Follow the wiring diagram (delivered with the unit, located at the inside of the service cover).
- Fix the earth wire to the stop valve attachment plate so that it does not slide.
- Make sure the electrical wiring does NOT obstruct proper reattachment of the service cover.

1 Remove the service cover. See "6.2.2 To open the outdoor unit" on page 9.

2 Strip insulation (20 mm) from the wires.

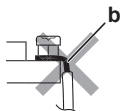
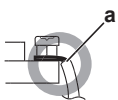

- a Strip wire end to this point  
b Excessive strip length may cause electrical shock or leakage.

3 Connect the interconnection cable and power supply as follows:

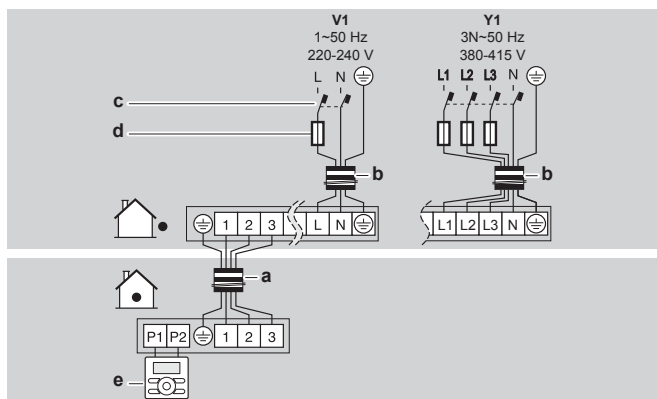

- a Interconnection cable  
b Power supply cable  
c Earth leakage circuit breaker  
d Fuse  
e User interface

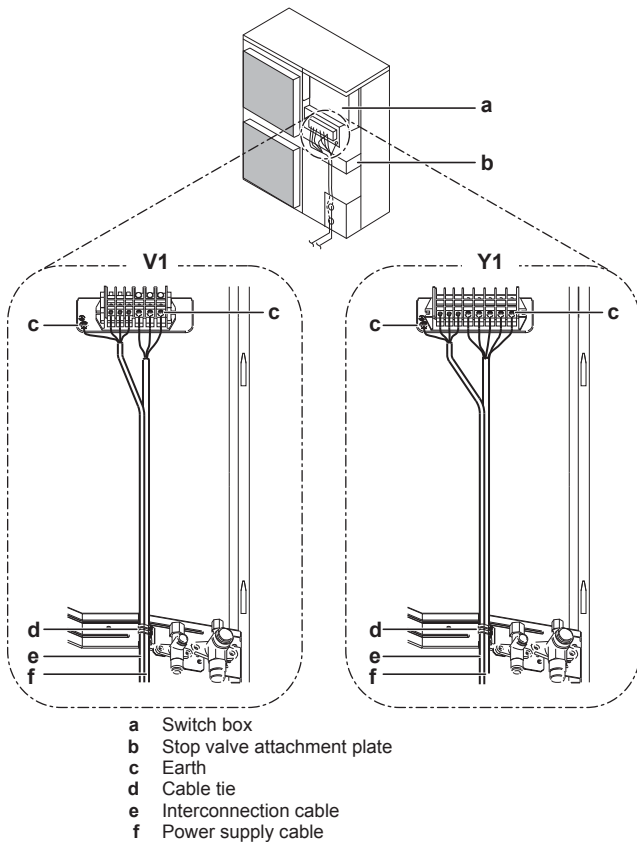

- 4 Fix the cables (power supply and interconnection cable) with a cable tie to the stop valve attachment plate.
- 5 Route the wiring through the frame and connect it to it.

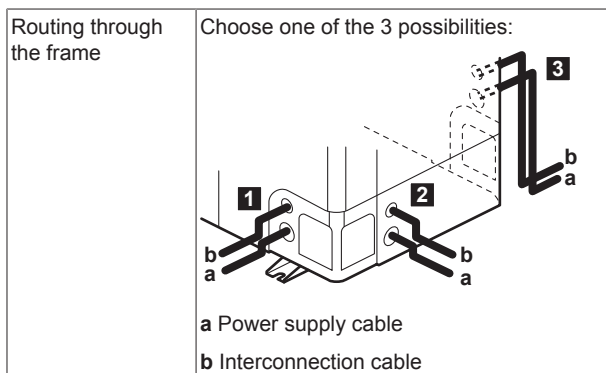

Connecting to the frame

When cables are routed from the unit, a protection sleeve for the conduits (PG insertions) can be inserted at the knockout hole.

When you do not use a wire conduit, protect the wires with vinyl tubes to prevent the edge of the knockout hole from cutting the wires.

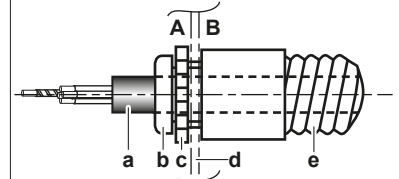

A Inside of the outdoor unit

B Outside of the outdoor unit

a Wire

b Bush

c Nut

d Frame

e Hose

- 6 Reattach the service cover. See "6.8.2 To close the outdoor unit" on page 20.
- 7 Connect an earth leakage circuit breaker and fuse to the power supply line.

## 6.8 Finishing the outdoor unit installation

### 6.8.1 To finish the outdoor unit installation

- 1 Insulate and fix the refrigerant piping and interconnection cable as follows:

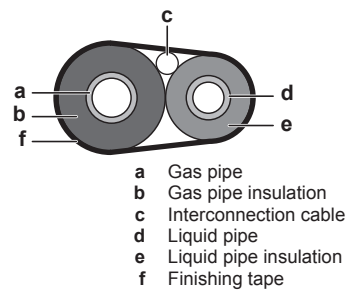

- 2 Install the service cover.

## 7 Commissioning

### 6.8.2 To close the outdoor unit



#### NOTICE

When closing the outdoor unit cover, make sure that the tightening torque does NOT exceed 4.1 N·m.

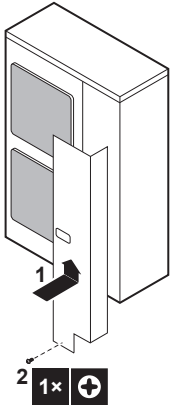

### 6.8.3 To check the insulation resistance of the compressor



#### NOTICE

If, after installation, refrigerant accumulates in the compressor, the insulation resistance over the poles can drop, but if it is at least 1 MΩ, then the unit will not break down.

- Use a 500 V mega-tester when measuring insulation.
- Do not use a mega-tester for low-voltage circuits.

- 1 Measure the insulation resistance over the poles.

If	Then
≥1 MΩ	Insulation resistance is OK. This procedure is finished.
<1 MΩ	Insulation resistance is not OK. Go to the next step.

- 2 Turn ON the power and leave it on for 6 hours.

**Result:** The compressor will heat up and evaporate any refrigerant in the compressor.

- 3 Measure the insulation resistance again.

## 7 Commissioning

### 7.1 Overview: Commissioning

This chapter describes what you have to do and know to commission the system after it is installed.

#### Typical workflow

Commissioning typically consists of the following stages:

- 1 Checking the "Checklist before test run".
- 2 Performing a test run for the system.

### 7.2 Precautions when commissioning



#### INFORMATION

During the first running period of the unit, the required power may be higher than stated on the nameplate of the unit. This phenomenon is caused by the compressor, that needs a continuous run time of 50 hours before reaching smooth operation and stable power consumption.



#### NOTICE

Before starting up the system, the unit **MUST** be energised for at least 6 hours. The crankcase heater needs to heat up the compressor oil to avoid oil shortage and compressor breakdown during startup.



#### NOTICE

**NEVER** operate the unit without thermistors and/or pressure sensors/switches. Burning of the compressor might result.



#### NOTICE

Do **NOT** operate the unit until the refrigerant piping is complete (when operated this way, the compressor will break).



#### NOTICE

**Cooling operation mode.** Perform the test run in cooling operation mode so that stop valves failing to open can be detected. Even if the user interface was set to heating operation mode, the unit will run in cooling operation mode during 2-3 minutes (although the user interface will display the heating icon), and then automatically switch to heating operation mode.



#### NOTICE

If you cannot operate the unit in test run, see ["7.5 Error codes when performing a test run" on page 21](#).



#### WARNING

If the panels on the indoor units are not installed yet, make sure to power OFF the system after finishing the test run. To do so, turn OFF operation via the user interface. Do **NOT** stop operation by turning OFF the circuit breakers.

### 7.3 Checklist before test run

Do **NOT** operate the system before the following checks are OK:

<input type="checkbox"/>	The <b>indoor units</b> are properly mounted.
<input type="checkbox"/>	In case a wireless user interface is used: The <b>indoor unit decoration panel</b> with infrared receiver is installed.
<input type="checkbox"/>	The <b>outdoor unit</b> is properly mounted.
<input type="checkbox"/>	The following <b>field wiring</b> has been carried out according to this document and the applicable legislation: <ul style="list-style-type: none"> <li>• Between the local supply panel and the outdoor unit</li> <li>• Between the outdoor unit and the indoor unit</li> </ul>
<input type="checkbox"/>	There are <b>NO missing phases</b> or <b>reversed phases</b> .
<input type="checkbox"/>	The system is properly <b>earthed</b> and the earth terminals are tightened.
<input type="checkbox"/>	The <b>fuses</b> or locally installed protection devices are installed according to this document, and have not been bypassed.
<input type="checkbox"/>	The <b>power supply voltage</b> matches the voltage on the identification label of the unit.

<input type="checkbox"/>	There are NO <b>loose connections</b> or damaged electrical components in the switch box.
<input type="checkbox"/>	The <b>insulation resistance</b> of the compressor is OK.
<input type="checkbox"/>	There are NO <b>damaged components</b> or <b>squeezed pipes</b> on the inside of the indoor and outdoor units.
<input type="checkbox"/>	There are NO <b>refrigerant leaks</b> .
<input type="checkbox"/>	The correct pipe size is installed and the <b>pipes</b> are properly insulated.
<input type="checkbox"/>	The <b>stop valves</b> (gas and liquid) on the outdoor unit are fully open.

### 7.4 To perform a test run



#### NOTICE

Do not interrupt the test run.



#### INFORMATION

In case you have to redo the test run, see the service manual.

#### 1 Perform introductory steps.

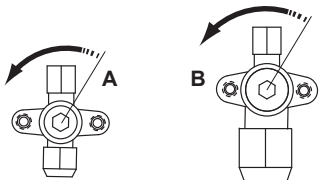
#	Action
1	Open the liquid stop valve (A) and gas stop valve (B) by removing the stem cap and turning counterclockwise with a hex wrench until it stops. 
2	Close the service cover to prevent electric shocks.
3	Turn ON power for at least 6 hours before starting operation to protect the compressor.
4	On the user interface, set the unit to cooling operation mode.

#### 2 On the user interface, turn ON the unit.

**Result:** The test run starts automatically. During the test run, the H2P test LED is ON. When the test run is done, the LED turns OFF.

### 7.5 Error codes when performing a test run

If the installation of the outdoor unit has NOT been done correctly, the following error codes may be displayed on the user interface:

Error code	Possible cause
Nothing displayed (the currently set temperature is not displayed)	<ul style="list-style-type: none"> <li>The wiring is disconnected or there is a wiring error (between power supply and outdoor unit, between outdoor unit and indoor units, between indoor unit and user interface).</li> <li>The fuse on the outdoor unit PCB has blown out.</li> </ul>
E3, E4 or L8	<ul style="list-style-type: none"> <li>The stop valves are closed.</li> <li>The air inlet or air outlet is blocked.</li> </ul>

Error code	Possible cause
E7	There is a missing phase in case of three-phase power supply units. <b>Note:</b> Operation will be impossible. Turn OFF the power, recheck the wiring, and switch two of the three electrical wires.
L4	The air inlet or air outlet is blocked.
U0	The stop valves are closed.
U2	<ul style="list-style-type: none"> <li>There is a voltage imbalance.</li> <li>There is a missing phase in case of three-phase power supply units. <b>Note:</b> Operation will be impossible. Turn OFF the power, recheck the wiring, and switch two of the three electrical wires.</li> </ul>
U4 or UF	The inter-unit branch wiring is not correct.
UA	The outdoor and indoor unit are incompatible.



#### NOTICE

- The reversed phase protection detector of this product only functions when the product starts up. Consequently reversed phase detection is not performed during normal operation of the product.
- The reversed phase protection detector is designed to stop the product in the event of an abnormality when the product is started up.
- Replace two of the three phases (L1, L2, and L3) during reverse-phase protection abnormality.

## 8 Hand-over to the user

Once the test run is finished and the unit operates properly, please make sure the following is clear for the user:

- Make sure that the user has the printed documentation and ask him/her to keep it for future reference. Inform the user that he can find the complete documentation on the url as earlier described in this manual.
- Explain the user how to properly operate the system and what he/she has to do in case of problems.
- Show the user what he/she has to do in relation to maintaining the unit.

## 9 Maintenance and service



#### NOTICE

Maintenance should preferably be carried out yearly by an installer or service agent.

### 9.1 Overview: Maintenance and service

This chapter contains information about:

- The yearly maintenance of the outdoor unit

## 10 Troubleshooting

### 9.2 Maintenance safety precautions



**DANGER: RISK OF ELECTROCUTION**



**DANGER: RISK OF BURNING**



**NOTICE: Risk of electrostatic discharge**

Before performing any maintenance or service work, touch a metal part of the unit in order to eliminate static electricity and to protect the PCB.

### 9.3 Checklist for yearly maintenance of the outdoor unit

Check the following at least once a year:

- Outdoor unit heat exchanger.

The heat exchanger of the outdoor unit can get blocked up due to dust, dirt, leaves, etc. It is recommended to clean the heat exchanger yearly. A blocked heat exchanger can lead to too low pressure or too high pressure leading to worse performance.

## 10 Troubleshooting

### 10.1 Overview: Troubleshooting

In case of problems:

- See "[7.5 Error codes when performing a test run](#)" on page 21.
- See the service manual.

#### Before troubleshooting

Carry out a thorough visual inspection of the unit and look for obvious defects such as loose connections or defective wiring.

### 10.2 Precautions when troubleshooting



**WARNING**

- When carrying out an inspection on the switch box of the unit, always make sure that the unit is disconnected from the mains. Turn off the respective circuit breaker.
- When a safety device was activated, stop the unit and find out why the safety device was activated before resetting it. NEVER bridge safety devices or change their values to a value other than the factory default setting. If you are unable to find the cause of the problem, call your dealer.



**DANGER: RISK OF ELECTROCUTION**



**WARNING**

Prevent hazard due to the inadvertent resetting of the thermal cut-out: this appliance must NOT be supplied through an external switching device, such as a timer, or connected to a circuit that is regularly turned ON and OFF by the utility.



**DANGER: RISK OF BURNING**

## 11 Disposal

### 11.1 Overview: Disposal

#### Typical workflow

Disposing of the system typically consists of the following stages:

- 1 Pumping down the system.
- 2 Dismantling the system according to the applicable legislation.
- 3 Treating the refrigerant, oil and other parts according to the applicable legislation.



**INFORMATION**

For more details, see the service manual.

### 11.2 About pump down

The unit is equipped with an automatic pump down function, with which you can collect all refrigerant from the system into the outdoor unit.

**Example:** To protect the environment, pump down when relocating the unit or when disposing of the unit.



**NOTICE**

The outdoor unit is equipped with a low pressure switch or a low pressure sensor to protect the compressor by turning it OFF. NEVER short-circuit the low pressure switch during pump down operation.

### 11.3 To pump down

- 1 Turn ON the main power supply switch.
- 2 Make sure the liquid stop valve and the gas stop valve are open.
- 3 Press the pump down button (BS4) for at least 8 seconds. BS4 is located on the PCB in the outdoor unit (see wiring diagram).

**Result:** The compressor and outdoor unit fan start automatically, and the indoor unit fan might start automatically.

- 4 ±2 minutes after the compressor started, close the **liquid stop valve**. If it is not closed properly during compressor operation, the system cannot be pumped down.
- 5 Once the compressor stops (after 2~5 minutes), close the **gas stop valve**.

**Result:** The pump down operation is finished. The user interface may display "U4" and the indoor pump may continue operating. This is NOT a malfunction. Even if you press the ON button on the user interface, the unit will NOT start. To restart the unit, turn OFF the main power supply switch and turn it ON again.

- 6 Turn OFF the main power supply switch.



**NOTICE**

Make sure to reopen both stop valves before restarting the unit.

## 12 Technical data

### 12.1 Overview: Technical data

This chapter contains information about:

- Dimensions and service space
- Components
- Piping diagram
- Wiring diagram
- Technical specifications

### 12.2 Dimensions and service space

#### 12.2.1 Dimensions: Outdoor unit

AZQS100+125 (dimensions in mm)

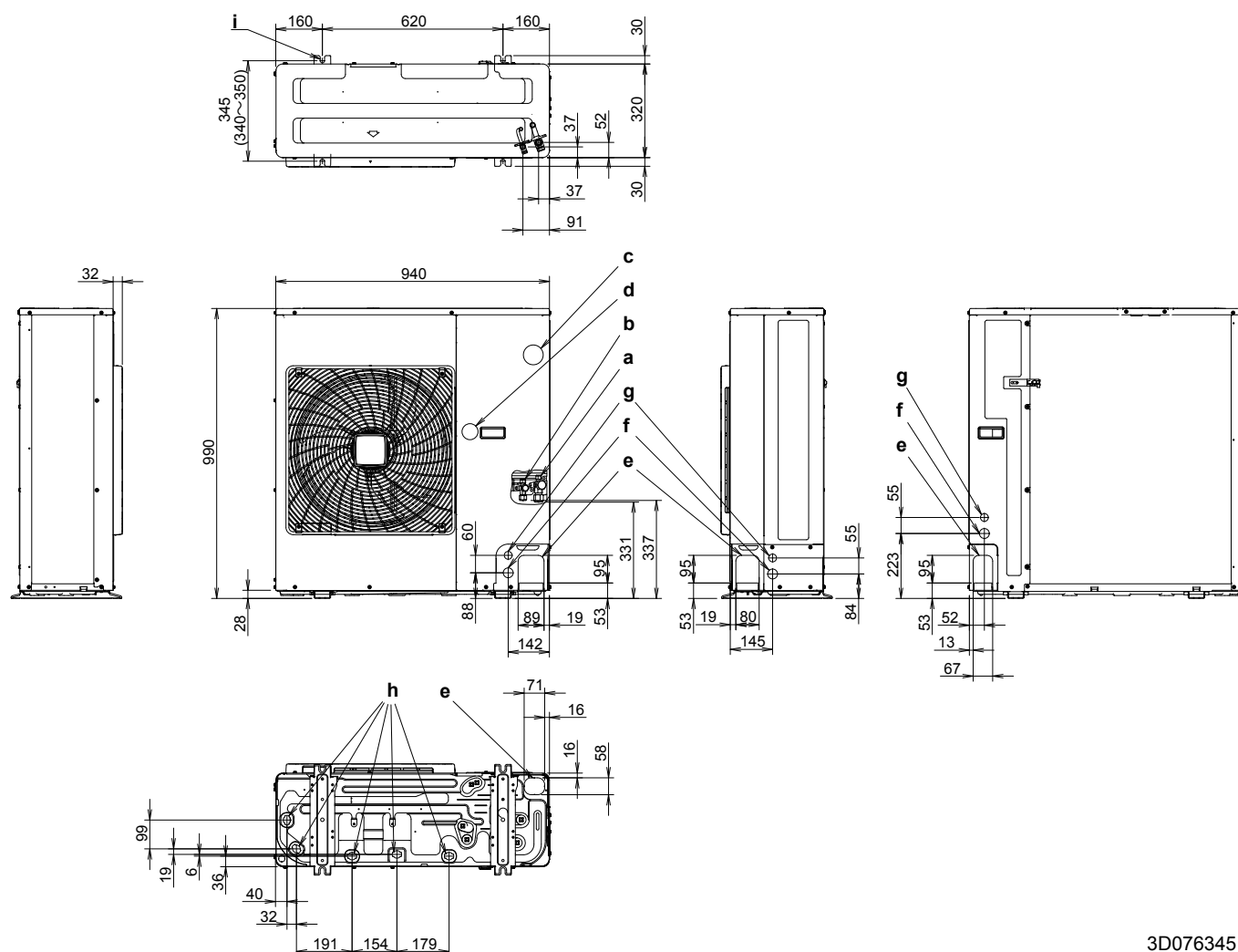

3D076345

- a Gas pipe connection (Ø15.9 flare connection)
- b Liquid pipe connection (Ø9.5 flare connection)
- c Internal service port (in the unit)
- d Earthing terminal M5 (in the switch box)
- e Refrigerant piping intake
- f Power supply wiring intake (knockout hole Ø34)
- g Control wiring intake (knockout hole Ø27)
- h Drain hole
- i Anchor point (bolt 4× M12)

## 12 Technical data

### AZQS140 (dimensions in mm)

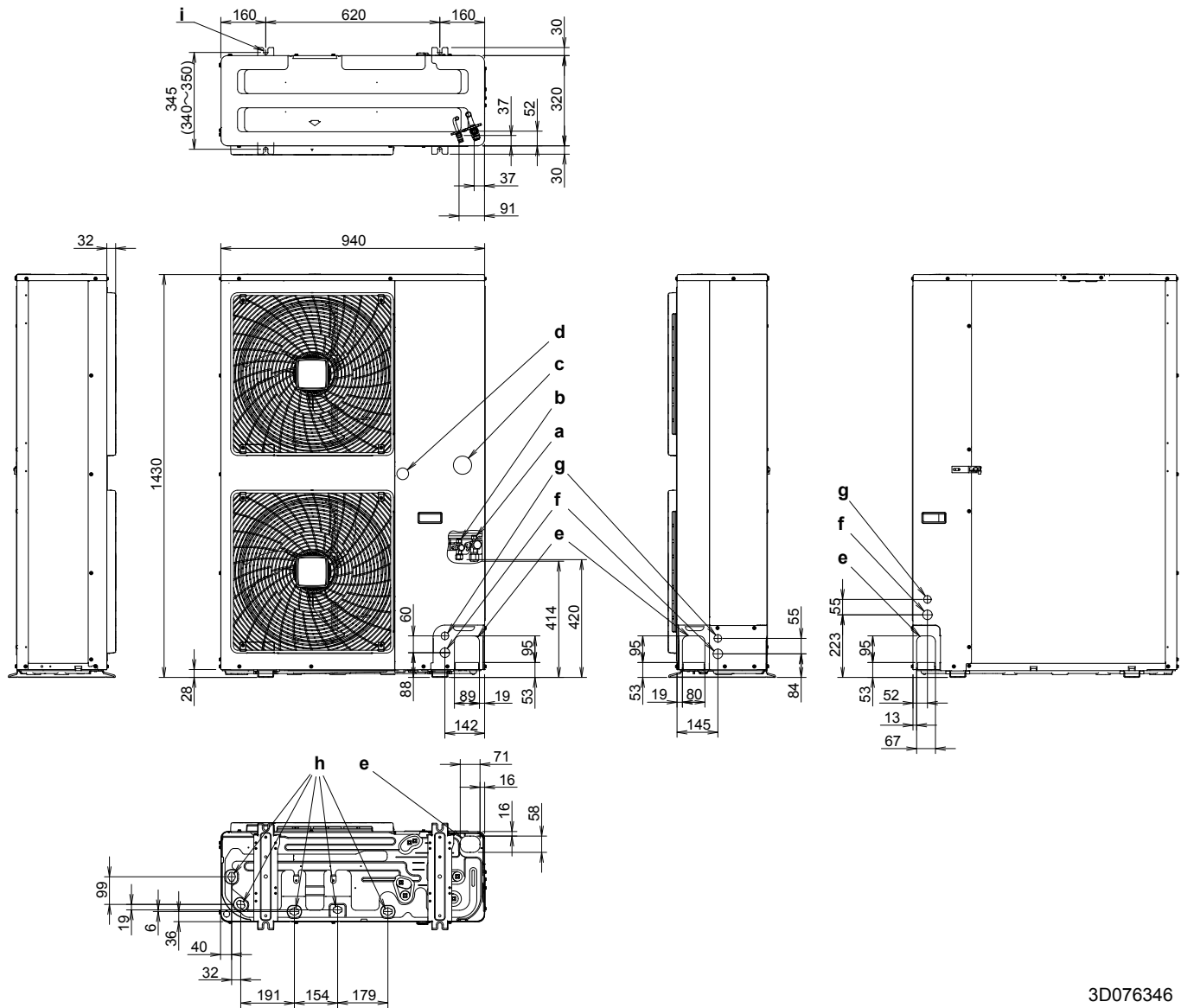

3D076346

- a Gas pipe connection (Ø15.9 flare connection)
- b Liquid pipe connection (Ø9.5 flare connection)
- c Internal service port (in the unit)
- d Earthing terminal M5 (in the switch box)
- e Refrigerant piping intake
- f Power supply wiring intake (knockout hole Ø34)
- g Control wiring intake (knockout hole Ø27)
- h Drain hole
- i Anchor point (bolt 4× M12)



12.2.2 Service space: Outdoor unit

<b>Suction side</b>	In the illustrations below, the service space at the suction side is based on 35°C DB and cooling operation. Forsee more space in the following cases: <ul style="list-style-type: none"> <li>When the suction side temperature regularly exceeds this temperature.</li> <li>When the heat load of the outdoor units is expected to regularly exceed the maximum operating capacity.</li> </ul>
<b>Discharge side</b>	Take refrigerant piping work into account when positioning the units. If your layout does not match any of the layouts below, contact your dealer.

Single unit | Single row of units

Layout	If		Then (mm)						
	Obstacles	Heights	a	b	c	d	e	e <sub>B</sub>	e <sub>D</sub>
<p>Single unit</p>	B	—		≥100					
	A, B, C	—		≥100	≥100	≥100			
	B, E	—		≥100			≥1000		≤500
	A, B, C, E	—		≥150	≥150	≥150		≥1000	≤500
	D	—					≥500		
	D, E	—					≥500	≥1000	≤500
	B, D	H <sub>B</sub> <H <sub>D</sub>   H <sub>D</sub> >H <sub>U</sub> H <sub>B</sub> >H <sub>D</sub>   H <sub>D</sub> <H <sub>U</sub>		≥100			≥500		
	B, D, E (Note 1)	H <sub>B</sub> <H <sub>D</sub>	H <sub>B</sub> ≤½H <sub>U</sub>	≥250			≥750	≥1000	≤500
			½H <sub>U</sub> <H <sub>B</sub> ≤H <sub>U</sub>	≥250			≥1000	≥1000	≤500
		H <sub>B</sub> >H <sub>D</sub>	H <sub>B</sub> >H <sub>U</sub>	NOT allowed					
H <sub>D</sub> >H <sub>U</sub>			NOT allowed						
<p>Single row of units</p>	A, B, C	—	≥200	≥300	≥1000				
	A, B, C, E	—	≥200	≥300	≥1000		≥1000		≤500
	D	—				≥1000			
	D, E	—				≥1000	≥1000	≤500	
	B, D	H <sub>B</sub> <H <sub>D</sub>	H <sub>D</sub> >H <sub>U</sub>	≥300			≥1000		
			H <sub>B</sub> >H <sub>D</sub>	≥250			≥1500		
			½H <sub>U</sub> <H <sub>D</sub> ≤H <sub>U</sub>	≥300			≥1500		
	B, D, E (Note 1)	H <sub>B</sub> <H <sub>D</sub>	H <sub>B</sub> ≤½H <sub>U</sub>	≥300			≥1000	≥1000	≤500
			½H <sub>U</sub> <H <sub>B</sub> ≤H <sub>U</sub>	≥300			≥1250	≥1000	≤500
		H <sub>B</sub> >H <sub>D</sub>	H <sub>B</sub> >H <sub>U</sub>	NOT allowed					
H <sub>D</sub> >H <sub>U</sub>			NOT allowed						
(Note 2)	H <sub>B</sub> >H <sub>D</sub>	H <sub>D</sub> ≤½H <sub>U</sub>	≥250			≥1500	≥1000	≤500	
		½H <sub>U</sub> <H <sub>D</sub> ≤H <sub>U</sub>	≥300			≥1500	≥1000	≤500	
	H <sub>D</sub> >H <sub>U</sub>	NOT allowed							

- A,B,C,D** Obstacles (walls/baffle plates)
- E** Obstacle (roof)
- a,b,c,d,e** Minimum service space between the unit and obstacles A, B, C, D and E
- e<sub>B</sub>** Maximum distance between the unit and the edge of obstacle E, in the direction of obstacle B
- e<sub>D</sub>** Maximum distance between the unit and the edge of obstacle E, in the direction of obstacle D
- H<sub>U</sub>** Height of the unit
- H<sub>B</sub>,H<sub>D</sub>** Height of obstacles B and D
- Note 1** Seal the bottom of the installation frame to prevent discharged air from flowing back to the suction side through the bottom of the unit.
- Note 2** Maximum two units can be installed.

## 12 Technical data

### Multiple rows of units

Layout	If	Then (mm)
	$H_B \leq \frac{1}{2} H_U$	$b \geq 250$
	$\frac{1}{2} H_U < H_B \leq H_U$	$b \geq 300$
	$H_B > H_U$	NOT allowed

### Stacked units (max. 2 levels)

If	Then
There is danger of drainage dripping and freezing between the upper and lower units.	<p>Install a roof between the upper and lower units.</p> <p>Install the upper unit high enough above the lower unit to prevent ice buildup at the upper unit's bottom plate.</p> <p><b>A Roof</b></p>
There is no danger of drainage dripping and freezing between the upper and lower units.	<p>It is not required to install a roof, but seal the gap between the upper and lower units to prevent discharged air from flowing back to the suction side through the bottom of the unit.</p> <p><b>B Sealed gap</b></p>

## 12.3 Components

### 12.3.1 Components: Outdoor unit

AZQS140\_V1

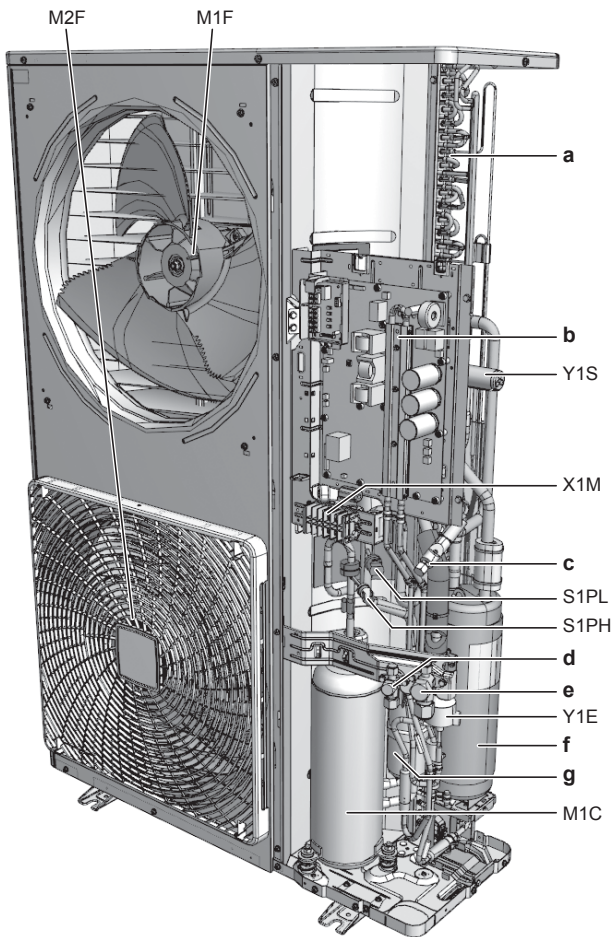

AZQS100+125\_V1

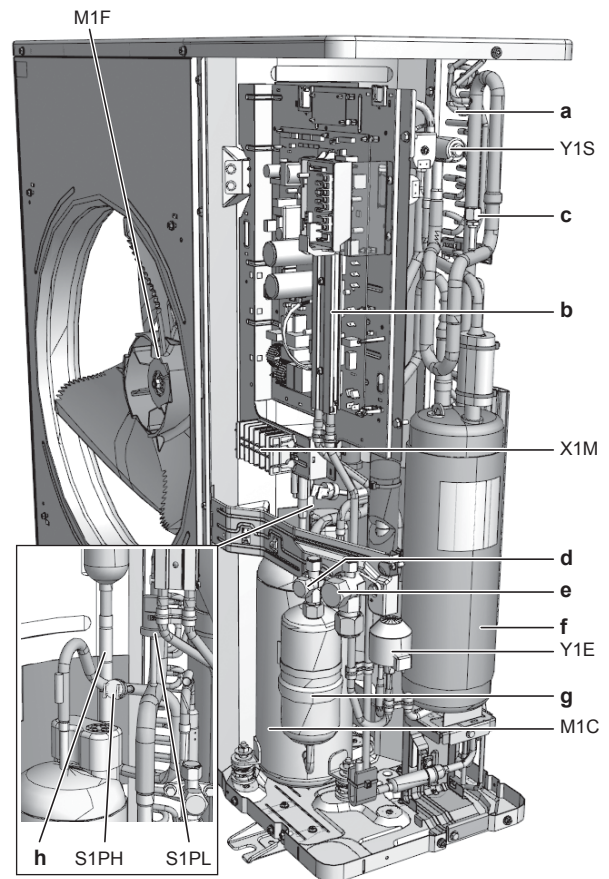

- a Heat exchanger
- b Switch box cooling
- c Internal service port
- d Stop valve with service port (liquid)
- e Stop valve with service port (gas)
- f Accumulator
- g Compressor accumulator
- h Check valve (only for AZQS100 and AZQS125)
- M1C Motor (compressor)
- M1F Motor (upper fan)
- M2F Motor (lower fan)
- S1PH High pressure switch
- S1PL Low pressure switch
- X1M Terminal (communication and power supply)
- Y1E Electronic expansion valve
- Y1S Solenoid valve (4-way valve)

## 12 Technical data

AZQS140\_Y1

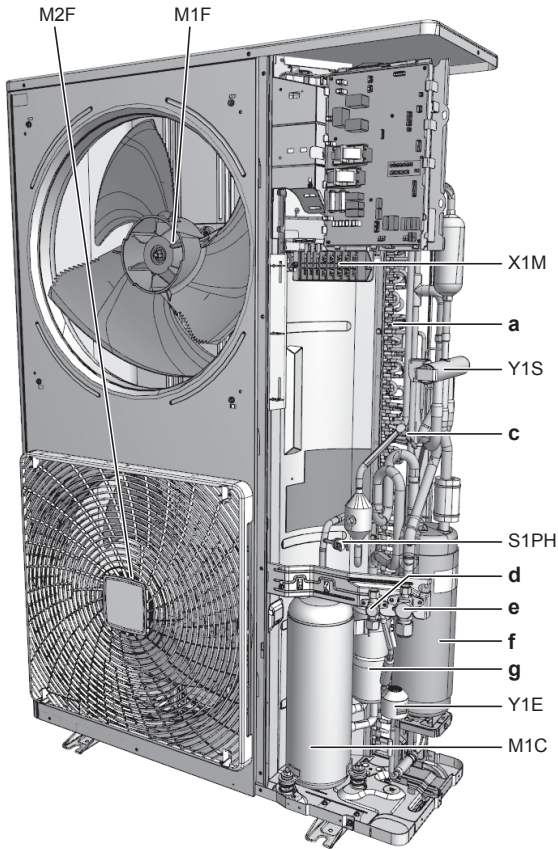

AZQS100+125\_Y1

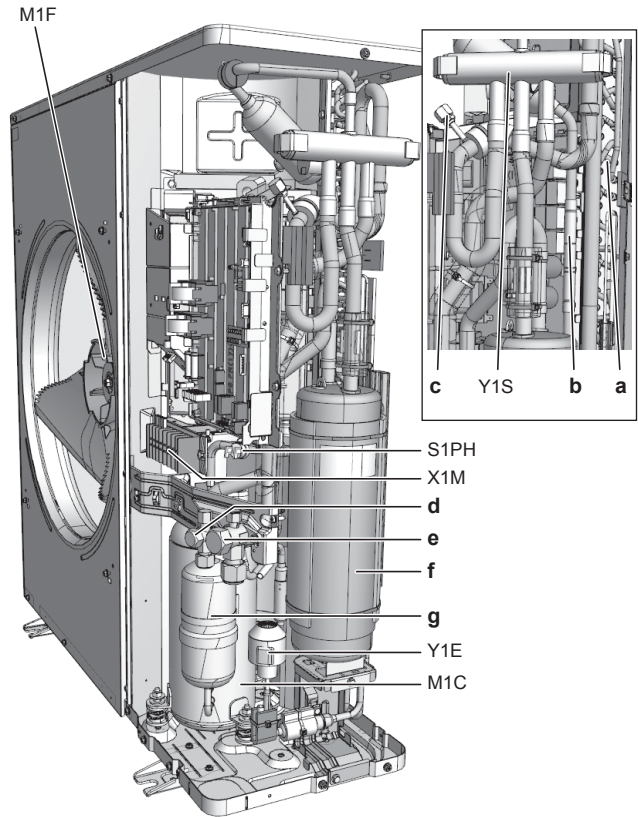

- a Heat exchanger
- b Check valve (only for AZQS100 and AZQS125)
- c Internal service port
- d Stop valve with service port (liquid)
- e Stop valve with service port (gas)
- f Accumulator
- g Compressor accumulator
- M1C Motor (compressor)
- M1F Motor (upper fan)
- M2F Motor (lower fan)
- S1PH High pressure switch
- X1M Terminal (communication and power supply)
- Y1E Electronic expansion valve
- Y1S Solenoid valve (4-way valve)

## 12.4 Piping diagram

### 12.4.1 Piping diagram: Outdoor unit

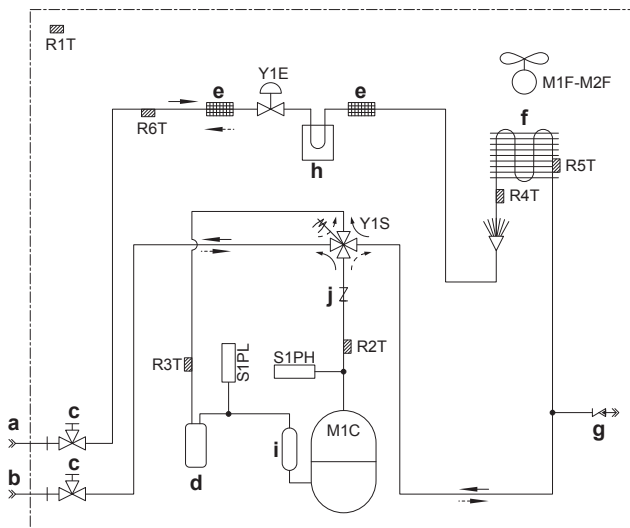

- a Field piping (liquid: Ø9.5 flare connection)
- b Field piping (gas: Ø15.9 flare connection)
- c Stop valve (with service port 5/16")
- d Accumulator
- e Filter
- f Heat exchanger
- g Internal service port 5/16"
- h Switch box cooling (only for AZQS\_V1)
- i Compressor accumulator
- j Check valve (only for AZQS100 and AZQS125)
- M1C Motor (compressor)
- M1F-M2F Motor (upper and lower fan)
- R1T Thermistor (air)
- R2T Thermistor (discharge)
- R3T Thermistor (suction)
- R4T Thermistor (heat exchanger)
- R5T Thermistor (heat exchanger middle)
- R6T Thermistor (liquid)
- S1PH High pressure switch
- S1PL Low pressure switch (only for AZQS\_V1)
- Y1E Electronic expansion valve
- Y1S Solenoid valve (4-way valve)
- Heating
- ⇄ Cooling

## 12 Technical data

### 12.5 Wiring diagram

#### 12.5.1 Wiring diagram: Outdoor unit

The wiring diagram is delivered with the unit, located at the inside of the service cover.



#### INFORMATION

For a legend explaining the figures below, refer to the end of this topic.

AZQS100\_V1

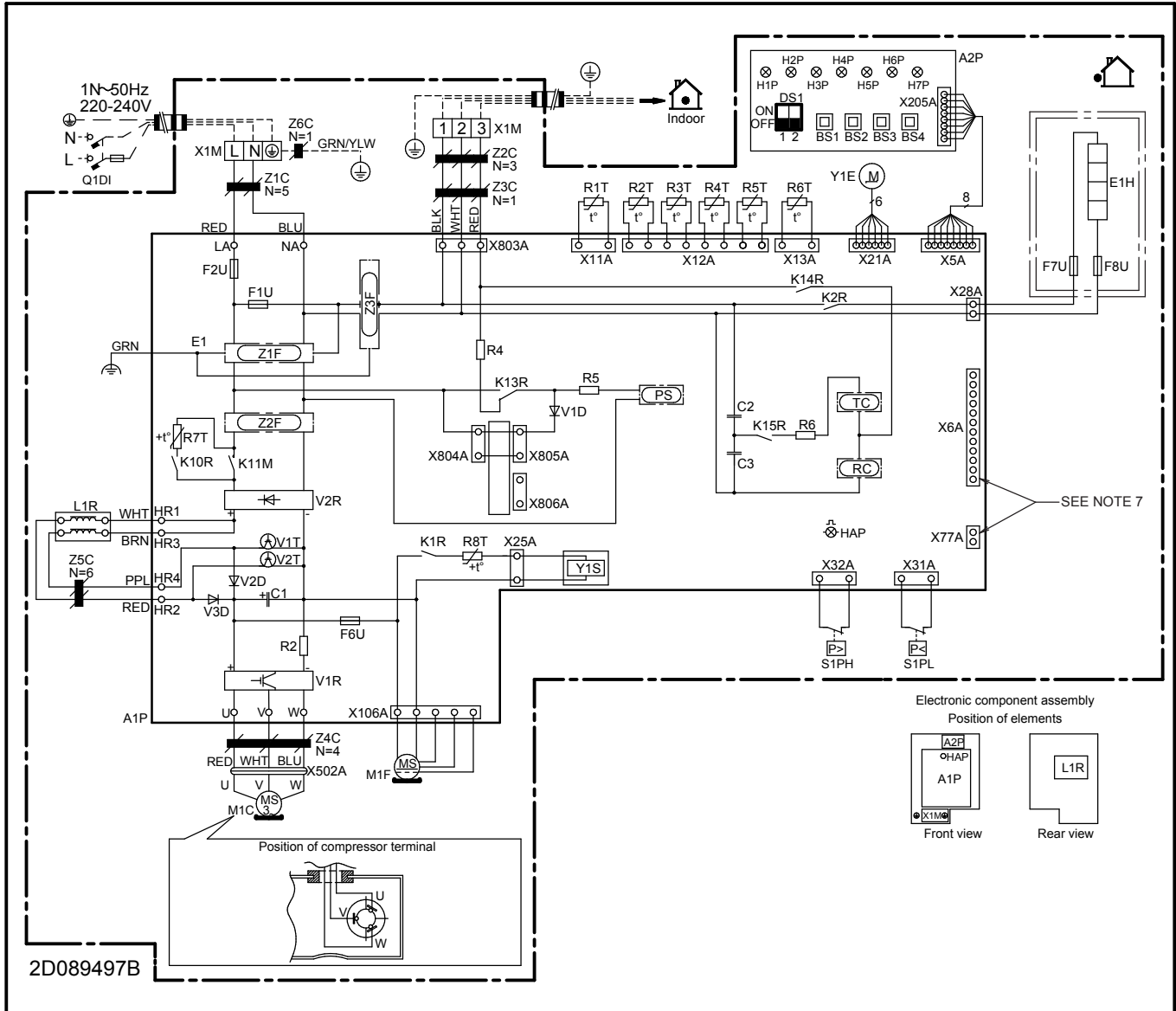

#### Notes:

1	Symbols (see legend).
2	Colours (see legend).
3	This wiring diagram applies only to the outdoor unit.
4	Refer to the wiring diagram sticker (on the back of the service cover) for how to use the BS1~BS4 and DS1 switches.
5	When operating, do not short-circuit protective devices S1PH and S1PL.
6	Refer to the service manual for instructions on how to set the selector switches (DS1). The factory setting of all switches is OFF.
7	Refer to the combination table and the option manual for how to connect the wiring to X6A, X28A and X77A.

AZQS100+125\_Y1

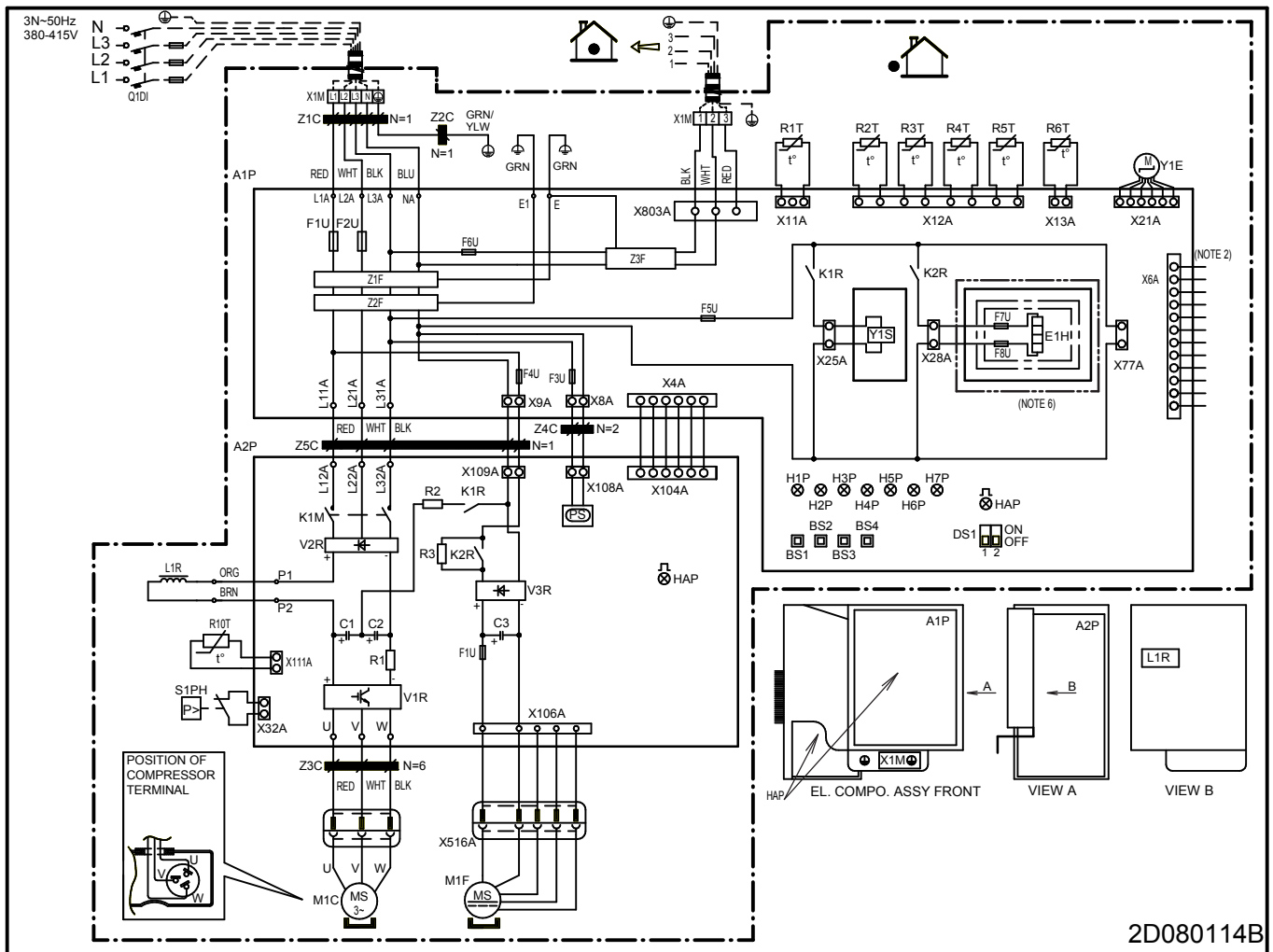

Notes:

1	This wiring diagram applies only to the outdoor unit.
2	Refer to the combination table and the option manual for how to connect the wiring to X6A, X28A and X77A.
3	Refer to the wiring diagram sticker (on the back of the service cover) for how to use the BS1~BS4 and DS1 switches.
4	When operating, do not short-circuit protective device S1PH.
5	Refer to the service manual for instructions on how to set the selector switches (DS1). The factory setting of all switches is OFF.
6	Only for 71 class.

# 12 Technical data

AZQS140\_V1

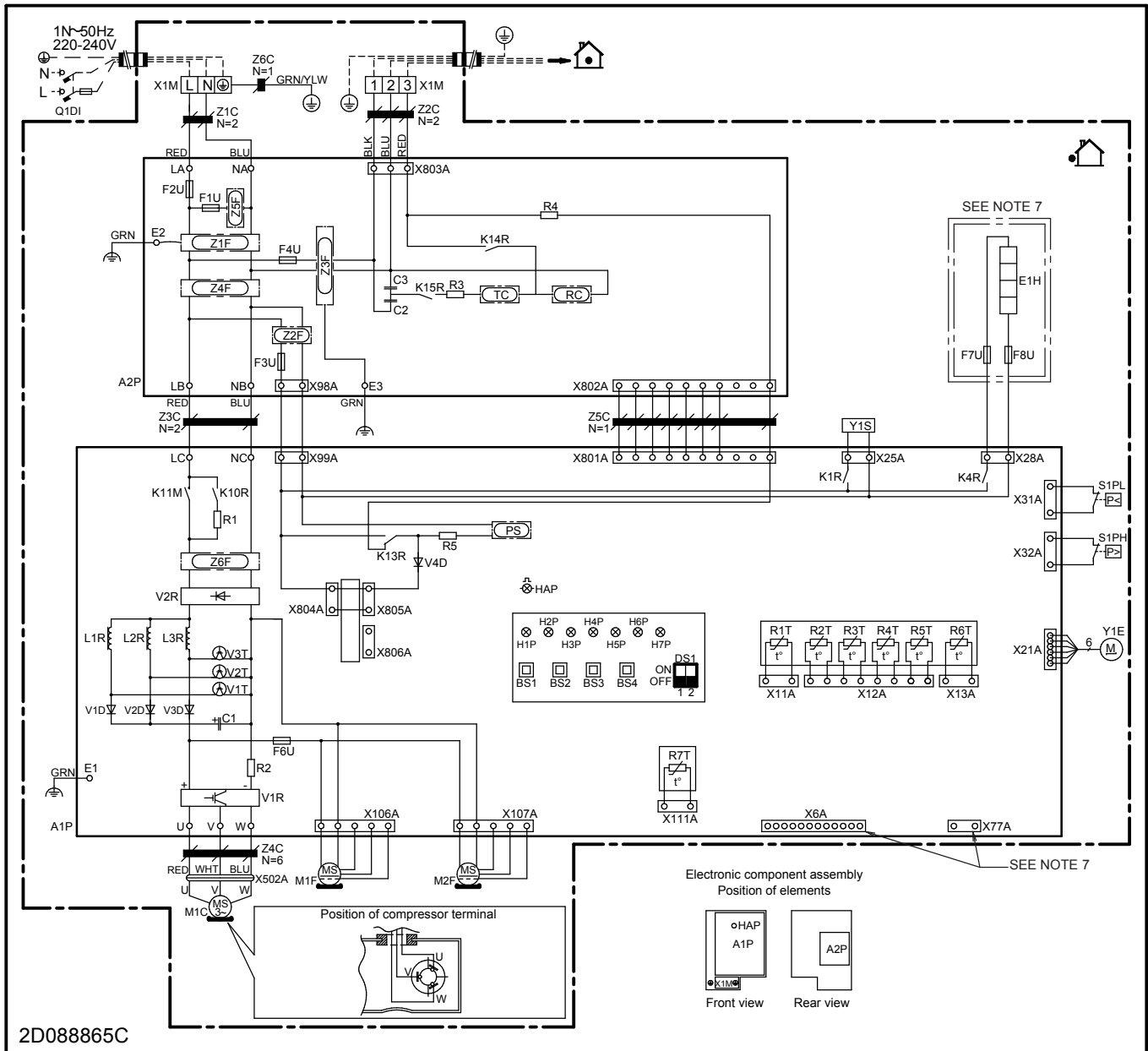

Notes:

1	Symbols (see legend).
2	Colours (see legend).
3	This wiring diagram applies only to the outdoor unit.
4	Refer to the wiring diagram sticker (on the back of the service cover) for how to use the BS1~BS4 and DS1 switches.
5	When operating, do not short-circuit protective devices S1PH and S1PL.
6	Refer to the service manual for instructions on how to set the selector switches (DS1). The factory setting of all switches is OFF.
7	Refer to the combination table and the option manual for how to connect the wiring to X6A, X28A and X77A.



AZQS140\_Y1

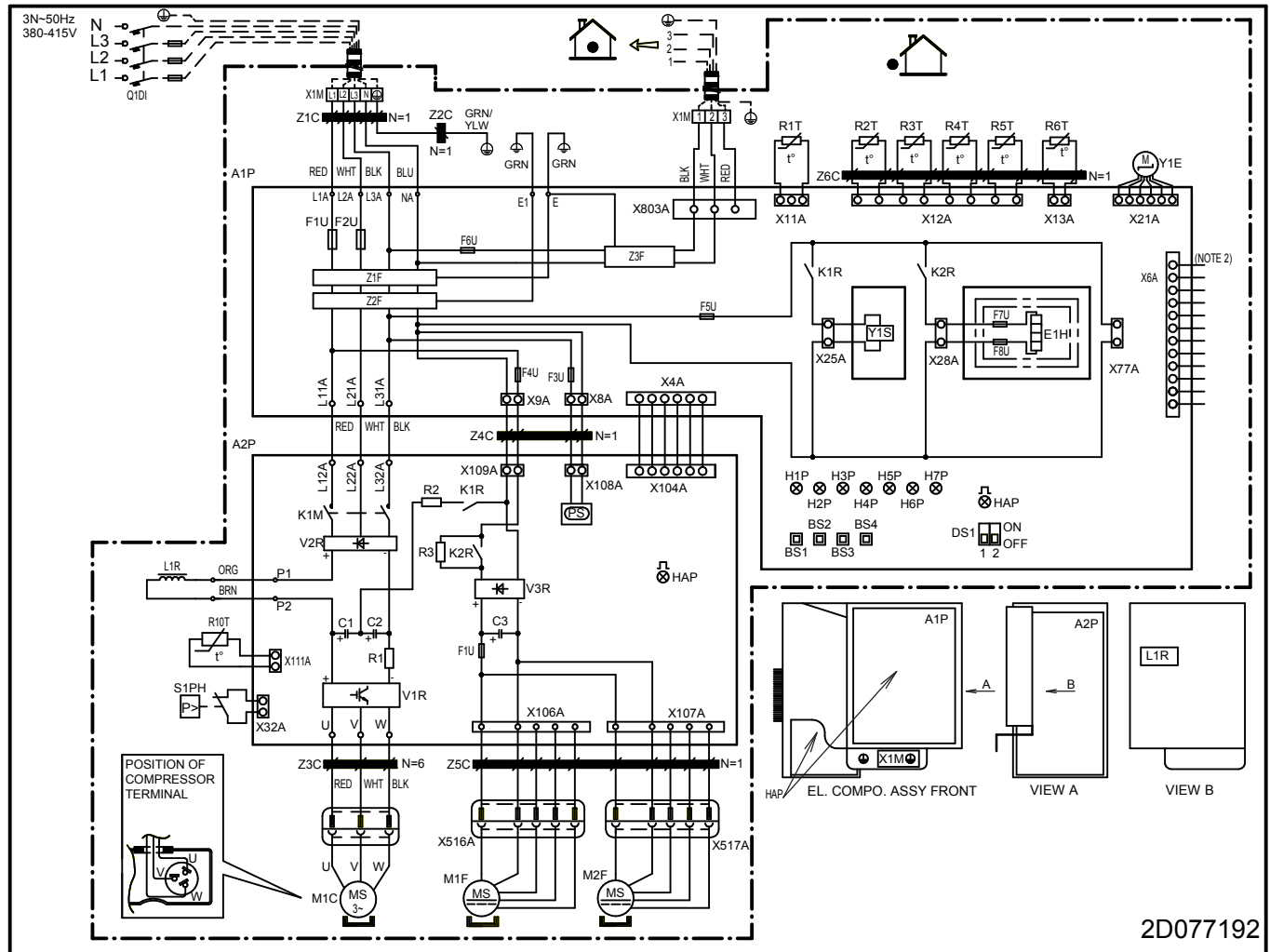

2D077192

Notes:

1	This wiring diagram applies only to the outdoor unit.
2	Refer to the combination table and the option manual for how to connect the wiring to X6A, X28A and X77A.
3	Refer to the wiring diagram sticker (on the back of the service cover) for how to use the BS1~BS4 and DS1 switches.
4	When operating, do not short-circuit protective device S1PH.
5	Refer to the service manual for instructions on how to set the selector switches (DS1). The factory setting of all switches is OFF.
6	Only for 71 class.

# 12 Technical data

AZQS125\_V1

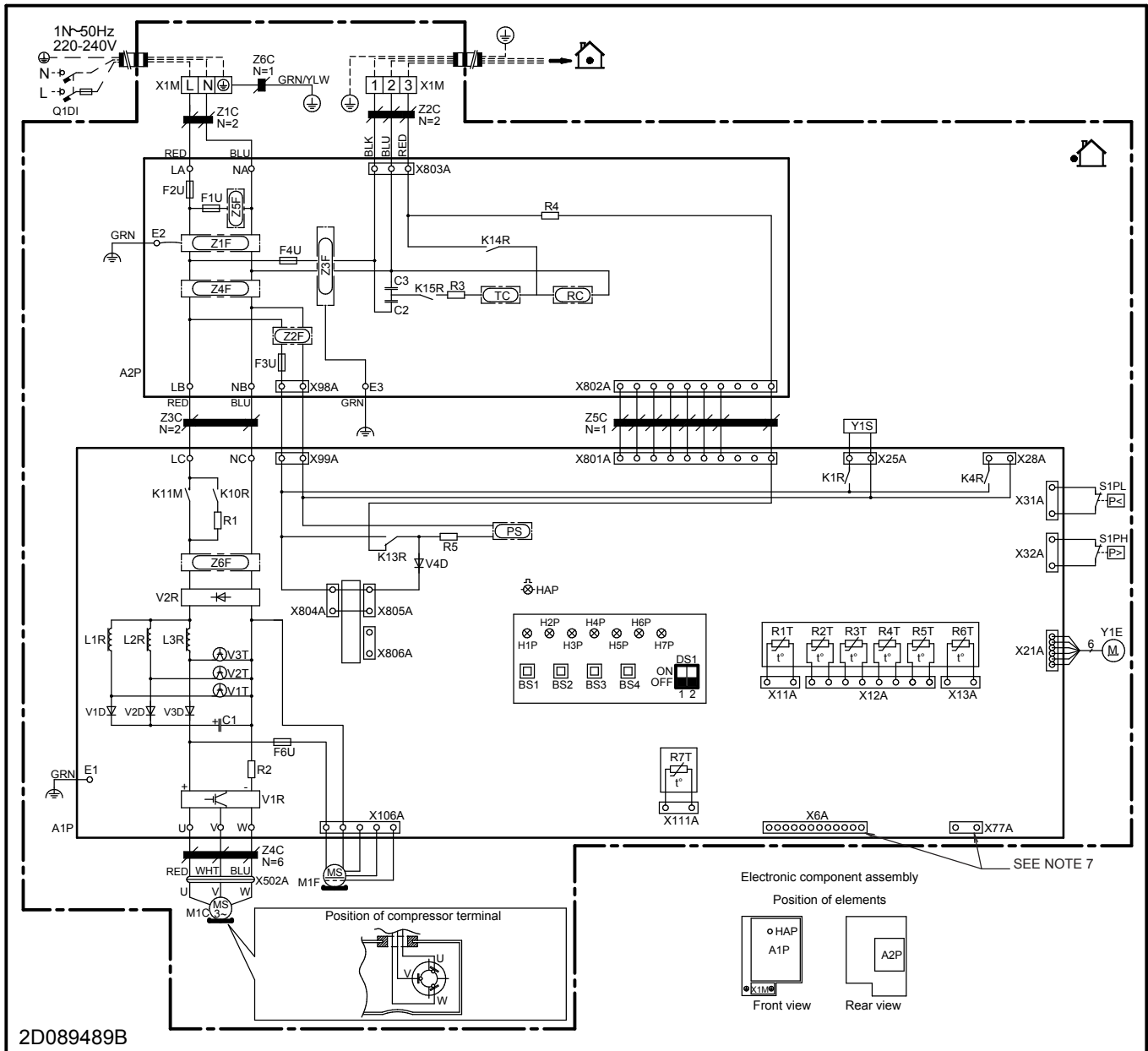

2D089489B









Notes:	
1	Symbols (see legend).
2	Colours (see legend).
3	This wiring diagram applies only to the outdoor unit.
4	Refer to the wiring diagram sticker (on the back of the service cover) for how to use the BS1~BS4 and DS1 switches.
5	When operating, do not short-circuit protective devices S1PH and S1PL.
6	Refer to the service manual for instructions on how to set the selector switches (DS1). The factory setting of all switches is OFF.
7	Refer to the combination table and the option manual for how to connect the wiring to X6A, X28A and X77A.

### Legend for wiring diagrams:

A1P~A2P	Printed circuit board
BS1~BS4	Push button switch
C1~C3	Capacitor
DS1	DIP switch
E1H	Bottom plate heater (option)
F1U~F8U (AZQS100_V1)	<ul style="list-style-type: none"> <li>▪ F1U, F2U: Fuse</li> <li>▪ F6U: Fuse (T 3.15 A / 250 V)</li> <li>▪ F7U, F8U: Fuse (F 1.0 A / 250 V)</li> </ul>
F1U~F8U (AZQS125+140_V1)	<ul style="list-style-type: none"> <li>▪ F1U~F4U: Fuse</li> <li>▪ F6U: Fuse (T 5.0 A / 250 V)</li> <li>▪ F7U, F8U: Fuse (F 1.0 A / 250 V)</li> </ul>
F1U~F8U (AZQS_Y1)	<ul style="list-style-type: none"> <li>▪ F1U, F2U: Fuse (31.5 A / 250 V)</li> <li>▪ F1U (A2P): Fuse (T 5.0 A / 250 V)</li> <li>▪ F3U~F6U: Fuse (T 6.3 A / 250 V)</li> <li>▪ F7U, F8U: Fuse (F 1.0 A / 250 V)</li> </ul>
H1P~H7P	Light-emitting diode (service monitor is orange)
HAP	Light-emitting diode (service monitor is green)
K1M, K11M	Magnetic contactor
K1R (AZQS_V1)	Magnetic relay (Y1S)
K1R (AZQS_Y1)	<ul style="list-style-type: none"> <li>▪ K1R (A1P): Magnetic relay (Y1S)</li> <li>▪ K1R (A2P): Magnetic relay</li> </ul>
K2R (AZQS100_V1)	Magnetic relay
K2R (AZQS_Y1)	<ul style="list-style-type: none"> <li>▪ K2R (A1P): Magnetic relay (E1H option)</li> <li>▪ K2R (A2P): Magnetic relay</li> </ul>
K10R, K13R~K15R	Magnetic relay
K4R	Magnetic relay E1H (option)
L1R~L3R	Reactor
M1C	Motor (compressor)
M1F	Motor (upper fan)
M2F	Motor (lower fan)
PS	Switching power supply
Q1DI	Earth leakage circuit breaker (field supply)
R1~R6	Resistor
R1T	Thermistor (air)
R2T	Thermistor (discharge)
R3T	Thermistor (suction)
R4T	Thermistor (heat exchanger)
R5T	Thermistor (heat exchanger middle)
R6T	Thermistor (liquid)
R7T (AZQS125+140_V1)	Thermistor (fin)
R7T, R8T (AZQS100_V1)	Thermistor (Positive Temperature Coefficient)
R10T (AZQS_Y1)	Thermistor (fin)
RC	Signal receiver circuit
S1PH	High pressure switch
S1PL	Low pressure switch

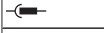
TC	Signal transmission circuit
V1D~V4D	Diode
V1R	IGBT power module
V2R, V3R	Diode module
V1T~V3T	Insulated gate bipolar transistor (IGBT)
X6A	Connector (option)
X1M	Terminal strip
Y1E	Electronic expansion valve
Y1S	Solenoid valve (4-way valve)
Z1C~Z6C	Noise filter (ferrite core)
Z1F~Z6F	Noise filter

### Symbols:

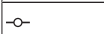
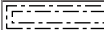
	Live
	Neutral
	Field wiring
	Terminal strip
	Connector
	Relay connector
	Connection
	Protective earth
	Noiseless earth
	Terminal
	Option

### Colours:

BLK	Black
BLU	Blue
BRN	Brown
GRN	Green
ORG	Orange
RED	Red
WHT	White
YLW	Yellow

## 12 Technical data

### 12.6 Technical specifications

#### 12.6.1 Technical specifications: Outdoor unit

##### Overview

The technical specifications are divided into the following tables:

AZQS_V1	<ul style="list-style-type: none"> <li>Technical specifications: AZQS_V1</li> <li>Electrical specifications: AZQS_V1</li> </ul>
AZQS_Y1	<ul style="list-style-type: none"> <li>Technical specifications: AZQS_Y1</li> <li>Electrical specifications: AZQS_Y1</li> </ul>

##### Technical specifications: AZQS\_V1

		AZQS100_V1	AZQS125_V1	AZQS140_V1
<b>Casing</b>				
Colour		Ivory white		
Material		Painted galvanised steel plate		
<b>Dimensions</b>				
Packing (H×W×D)		1170×1015×422 mm		1610×1015×422 mm
Unit (H×W×D)		990×940×320 mm		1430×940×320 mm
<b>Weight</b>				
Machine weight				
Gross weight				
<b>Heat exchanger</b>				
Fin	Type	WF fin		
	Treatment	Anti-corrosion treatment (PE)		
<b>Fan</b>				
Type		Propeller		
Quantity		1		2
Air flow rate (nominal at 230 V)	Cooling	76 m <sup>3</sup> /min	77 m <sup>3</sup> /min	83 m <sup>3</sup> /min
	Heating	83 m <sup>3</sup> /min		62 m <sup>3</sup> /min
Discharge direction		Horizontal		
Motor	Quantity	1		2
	Model	Brushless DC motor		
	Position			
	Output	200 W		94 W
	Drive	Direct drive		
<b>Compressor</b>				
Quantity		1		
Motor	Type	Hermetically sealed swing compressor		
	Crankcase heater			
<b>Operation range</b>				
Cooling	Minimum	See operation range drawing		
	Maximum			
Heating	Minimum			
	Maximum			
<b>Sound level</b>				
Nominal – Cooling	Sound power	70 dBA	71 dBA	70 dBA
	Sound pressure	53 dBA	54 dBA	53 dBA
Nominal – Heating	Sound power			
	Sound pressure	57 dBA	58 dBA	54 dBA
Night quiet - Cooling	Sound pressure	49 dBA		
Night quiet - Heating	Sound pressure			
<b>Refrigerant</b>				
Type		R410A		
Charge		2.9 kg		4.0 kg

	AZQS100_V1	AZQS125_V1	AZQS140_V1
Control	Expansion valve (electronic type)		
Nr. of circuits	1		
<b>Refrigerant oil</b>			
Type	FVC50K		
Charged volume	0.9 l		1.35 l
<b>PED</b>			
Category of unit	1		
	Excluded from PED due to article 1, item 3.6 of 97/23/EC		
<b>Piping connections</b>			
Liquid	Quantity	1	
	Type	Flare connection	
	Diameter (OD)	Ø9.52 mm	
Gas	Quantity	1	
	Type	Flare connection	
	Diameter (OD)	Ø15.9 mm	
Drain	Quantity	5	
	Type	Hole	
	Diameter (OD)	Ø26 mm	
Piping length	Minimum	5 m	
	Maximum	50 m	
	Equivalent	70 m	
	Chargeless	30 m	
Additional refrigerant charge	See "To determine the additional refrigerant amount"		
Maximum height difference between outdoor unit and indoor unit	30 m		
Maximum interunit level difference	0.5 m		
Heat insulation	Both liquid and gas pipes		
<b>Defrost method</b>	Reverse cycle		
<b>Defrost control</b>	Sensor for outdoor heat exchanger temperature		
<b>Capacity control method</b>	Inverter-controlled		
<b>Capacity control</b>			
Cooling	Minimum		
	Maximum		
Heating	Minimum		
	Maximum		
<b>Safety devices</b>	High pressure switch / low pressure switch / fan motor thermal protector / fuse		
<b>Standard accessories</b>	1 installation manual / 2 tie wraps		

**Electrical specifications: AZQS\_V1**

	AZQS100_V1	AZQS125_V1	AZQS140_V1
<b>Power supply</b>			
Name	V1		
Phase	1~		
Frequency	50 Hz		
Voltage	220-240 V		
Voltage range	Minimum	198 V	
	Maximum	264 V	
<b>Current</b>			
Nominal running current			
Starting current			
Z <sub>max</sub>	Complies to EN 61000-3-11		
Minimum S <sub>sc</sub> value	Equipment complying with EN 61000-3-12 <sup>(a)</sup>		
Maximum running current			
Recommended fuses	32 A		40 A
<b>Wiring connections</b>			

## 12 Technical data

	AZQS100_V1	AZQS125_V1	AZQS140_V1
For power supply	See "Connecting the electrical wiring"		
For connection with indoor			
<b>Power supply intake</b>	Outdoor unit only		

- (a) European/International Technical Standard setting the limits for harmonic currents produced by equipment connected to public low-voltage systems with input current  $>16$  A and  $\leq 75$  A per phase.

## Technical specifications: AZQS\_Y1

		AZQS100_Y1	AZQS125_Y1	AZQS140_Y1
<b>Casing</b>				
Colour		Ivory white		
Material		Painted galvanised steel plate		
<b>Dimensions</b>				
Packing (H×W×D)		1170×1015×422 mm		1610×1015×422 mm
Unit (H×W×D)		990×940×320 mm		1430×940×320 mm
<b>Weight</b>				
Machine weight		82 kg		101 kg
Gross weight		88 kg		108 kg
<b>Heat exchanger</b>				
Fin	Type	WF fin		
	Treatment	Anti-corrosion treatment (PE)		
<b>Fan</b>				
Type		Propeller		
Quantity		1		2
Air flow rate (nominal at 230 V)	Cooling	76 m <sup>3</sup> /min	77 m <sup>3</sup> /min	83 m <sup>3</sup> /min
	Heating	83 m <sup>3</sup> /min		62 m <sup>3</sup> /min
Discharge direction		Horizontal		
Motor	Quantity	1		2
	Model	Brushless DC motor		
	Position			
	Output	200 W		94 W
	Drive	Direct drive		
<b>Compressor</b>				
Quantity		1		
Motor	Type	Hermetically sealed swing compressor		
	Starting method	Inverter-driven		
	Crankcase heater			
<b>Operation range</b>				
Cooling	Minimum	See operation range drawing		
	Maximum			
Heating	Minimum			
	Maximum			
<b>Sound level</b>				
Nominal – Cooling	Sound power	70 dBA	71 dBA	70 dBA
	Sound pressure	53 dBA	54 dBA	53 dBA
Nominal – Heating	Sound power			
	Sound pressure	57 dBA	58 dBA	54 dBA
Night quiet - Cooling	Sound pressure	49 dBA		
Night quiet - Heating	Sound pressure			
<b>Refrigerant</b>				
Type		R410A		
Charge		2.9 kg		4.0 kg
Control		Expansion valve (electronic type)		
Nr. of circuits		1		
<b>Refrigerant oil</b>				
Type		FVC50K		
Charged volume		0.9 l		1.35 l
<b>PED</b>				
Category of unit		1		
		Excluded from PED due to article 1, item 3.6 of 97/23/EC		
<b>Piping connections</b>				

## 12 Technical data

		AZQS100_Y1	AZQS125_Y1	AZQS140_Y1
Liquid	Quantity	1		
	Type	Flare connection		
	Diameter (OD)	Ø9.52 mm		
Gas	Quantity	1		
	Type	Flare connection		
	Diameter (OD)	Ø15.9 mm		
Drain	Quantity	5		
	Type	Hole		
	Diameter (OD)	Ø26 mm		
Piping length	Minimum	5 m		
	Maximum	50 m		
	Equivalent	70 m		
	Chargeless	30 m		
Additional refrigerant charge		See "To determine the additional refrigerant amount"		
Maximum height difference between outdoor unit and indoor unit		30 m		
Maximum interunit level difference		0.5 m		
Heat insulation		Both liquid and gas pipes		
<b>Defrost method</b>		Reverse cycle		
<b>Defrost control</b>		Sensor for outdoor heat exchanger temperature		
<b>Capacity control method</b>		Inverter-controlled		
<b>Capacity control</b>				
Cooling	Minimum			
	Maximum			
Heating	Minimum			
	Maximum			
<b>Safety devices</b>		High pressure switch / fan motor thermal protector / fuse		
<b>Standard accessories</b>		1 installation manual / 2 tie wraps		

### Electrical specifications: AZQS\_Y1

		AZQS100_Y1	AZQS125_Y1	AZQS140_Y1
<b>Power supply</b>				
Name		Y1		
Phase		3N~		
Frequency		50 Hz		
Voltage		380-415 V		
Voltage range	Minimum	342 V		
	Maximum	456 V		
<b>Current</b>				
Nominal running current				
Starting current				
$Z_{max}$		Complies to EN 61000-3-11		
Maximum running current				
Recommended fuses		16 A	20 A	25 A
<b>Wiring connections</b>				
For power supply		See "Connecting the electrical wiring"		
For connection with indoor				
<b>Power supply intake</b>		Outdoor unit only		



## 13 Glossary

### **Dealer**

Sales distributor for the product.

### **Authorized installer**

Technical skilled person who is qualified to install the product.

### **User**

Person who is owner of the product and/or operates the product.

### **Applicable legislation**

All international, European, national and local directives, laws, regulations and/or codes that are relevant and applicable for a certain product or domain.

### **Service company**

Qualified company which can perform or coordinate the required service to the product.

### **Installation manual**

Instruction manual specified for a certain product or application, explaining how to install, configure and maintain it.

### **Operation manual**

Instruction manual specified for a certain product or application, explaining how to operate it.

### **Accessories**

Labels, manuals, information sheets and equipment that are delivered with the product and that need to be installed according to the instructions in the accompanying documentation.

### **Optional equipment**

Equipment made or approved by Daikin that can be combined with the product according to the instructions in the accompanying documentation.

### **Field supply**

Equipment not made by Daikin that can be combined with the product according to the instructions in the accompanying documentation.

