

# 1 Features

- Flat front panel: its stylish appearance blends easily within any interior décor and is more easy to clean.
- Lightweight and compact
- Home leave operation saves energy during absence
- Movement sensor saves power consumption in unoccupied rooms
- Dual air discharge flow for better air distribution
- Titanium apatite photocatalytic air purification filter
- Indoor / outdoor unit silent operation
- Night quiet mode (only in multi application and cooling only mode)



8

1

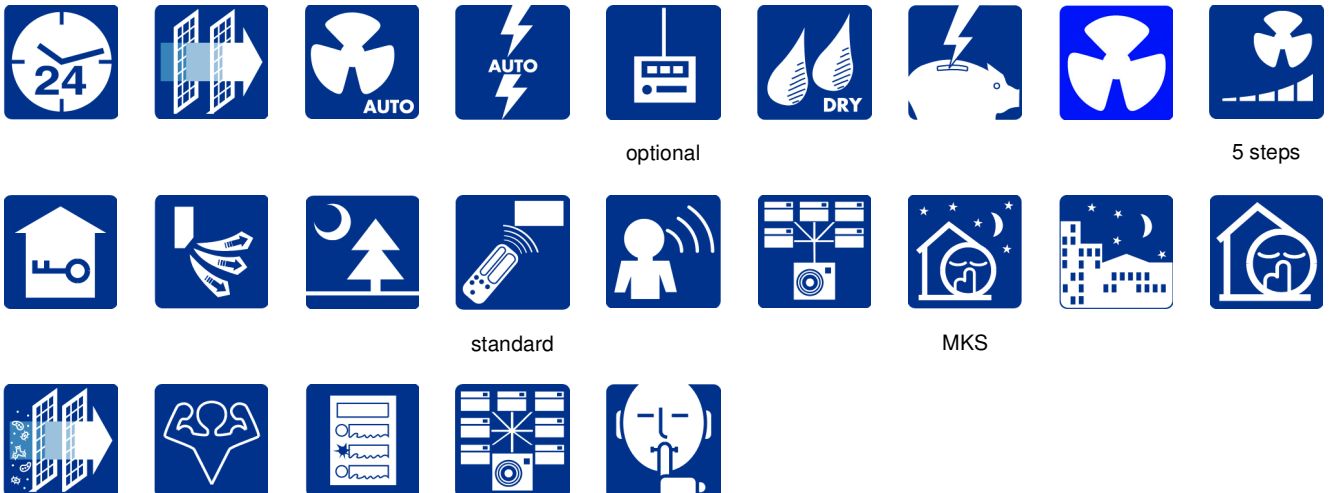

optional

5 steps

standard

MKS

## 2 Specifications

2-1 FOR INDOOR UNITS ONLY			FTKS60FV1B	FTKS71FV1B
Nominal input (Indoor only)	Cooling	kW	0.04	0.045

2-2 TECHNICAL SPECIFICATIONS				FTKS60FV1B	FTKS71FV1B
Casing	Colour			White	
Dimensions	Packing	Height	mm	337	337
		Width	mm	1147	1147
		Depth	mm	366	366
	Unit	Height	mm	290	290
		Width	mm	1050	1050
		Depth	mm	238	238
Weight	Unit		kg	12	12
	Packed Unit		kg	17	17
Heat Exchanger	Dimensions	Length	mm	863	863
		Nr of Rows		2	2
		Fin Pitch	mm	1.4	1.4
		Nr of Stages		16	16
	Tube type		Hi-XA (7)		
	Fin		Type ML fin (Multi louver)		
Fan	Type			Cross flow fan	
	Quantity			1	1
Air Flow Rate	Cooling	High	m <sup>3</sup> /min	16.2	17.4
		Medium	m <sup>3</sup> /min	13.6	14.6
		Low	m <sup>3</sup> /min	11.4	11.6
		Silent Operation	m <sup>3</sup> /min	10.2	10.6
Fan	Motor	Quantity		1	1
		Model		ARW30R8P43DA	
		Number of steps		5	5
Motor	Speed (cooling)	High	rpm	1330	1410
		Medium	rpm	1170	1220
		Low	rpm	1010	1040
		Silent Operation	rpm	920	950
Fan	Motor	Output (high)	W	43	43
Cooling	Sound Power	Medium	dBA	61	62
	Sound Pressure	High	dBA	45	46
		Medium	dBA	41	42
		Low	dBA	36	37
		Silent Operation	dBA	33	34
Refrigerant	Type			R-410A	
Piping connections	Liquid (OD)	Diameter (OD)	mm	6.4	6.4
	Gas	Diameter (OD)	mm	12.7	15.9
	Drain	Diameter (OD)	mm	18	18
	Heat Insulation			Both liquid and gas pipes	
Air Filter			Removable/washable/Mildew proof		
Air direction control			Right, Left, Horizontal, Downward		
Temperature control			Microcomputer control		

## 2 Specifications

2-2 TECHNICAL SPECIFICATIONS			FTKS60FV1B	FTKS71FV1B
Standard Accessories	Item	Titanium apatite photocatalytic air purification filter		
	Quantity	2		2
	Item	Operation manual		
	Quantity	1		1
	Item	Installation manual		
	Quantity	1		1
	Item	Batteries		
	Quantity	2		2
	Item	Remote control holder		
	Quantity	1		1
	Item	Mounting plate		
	Quantity	1		1
	Item	Indoor unit fixing screws		
	Quantity	2		2
Item	Wireless remote control			
Quantity	1		1	

2-3 ELECTRICAL SPECIFICATIONS				FTKS60FV1B	FTKS71FV1B
Power Supply	Name			V1	
	Phase			1	1
	Frequency	Hz		50	50
	Voltage	V		220-240	
Current	Nominal running current (RLA)	Cooling	A	0.18	0.20
	Maximum Running Current		A	0.19	0.21
Wiring connections	For Power Supply	Quantity		3	3
		Remark		4 for interunit wiring (including earth wiring)	

### 3 Dimensional drawing & centre of gravity

#### 3 - 1 Dimensional drawing

**FTKS50-60F**

The mark (→) shows piping direction

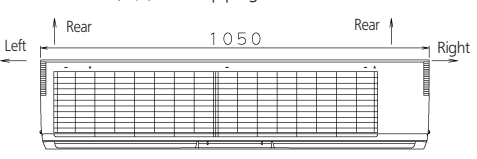
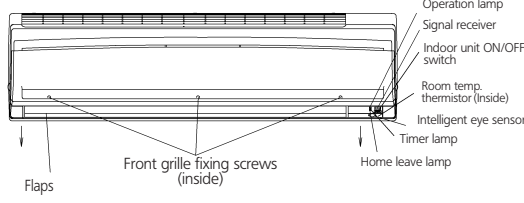
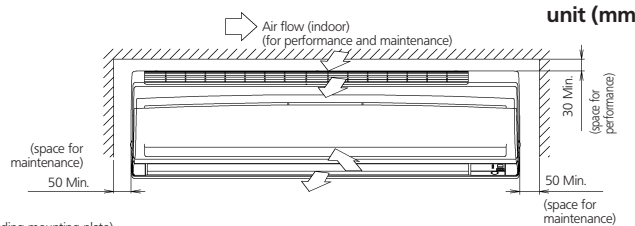
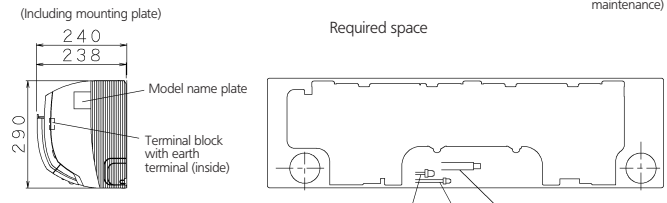
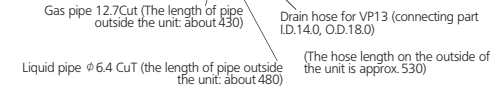
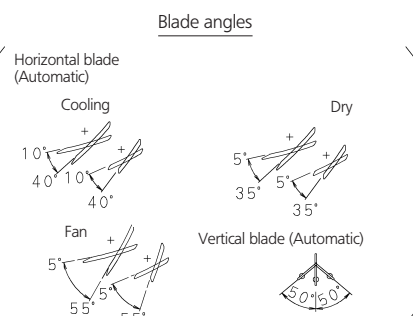
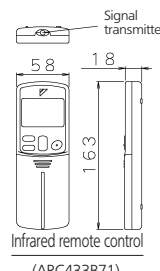
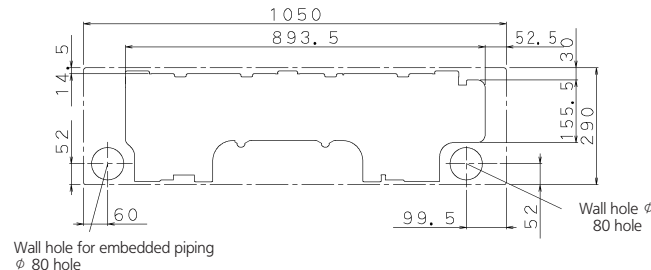







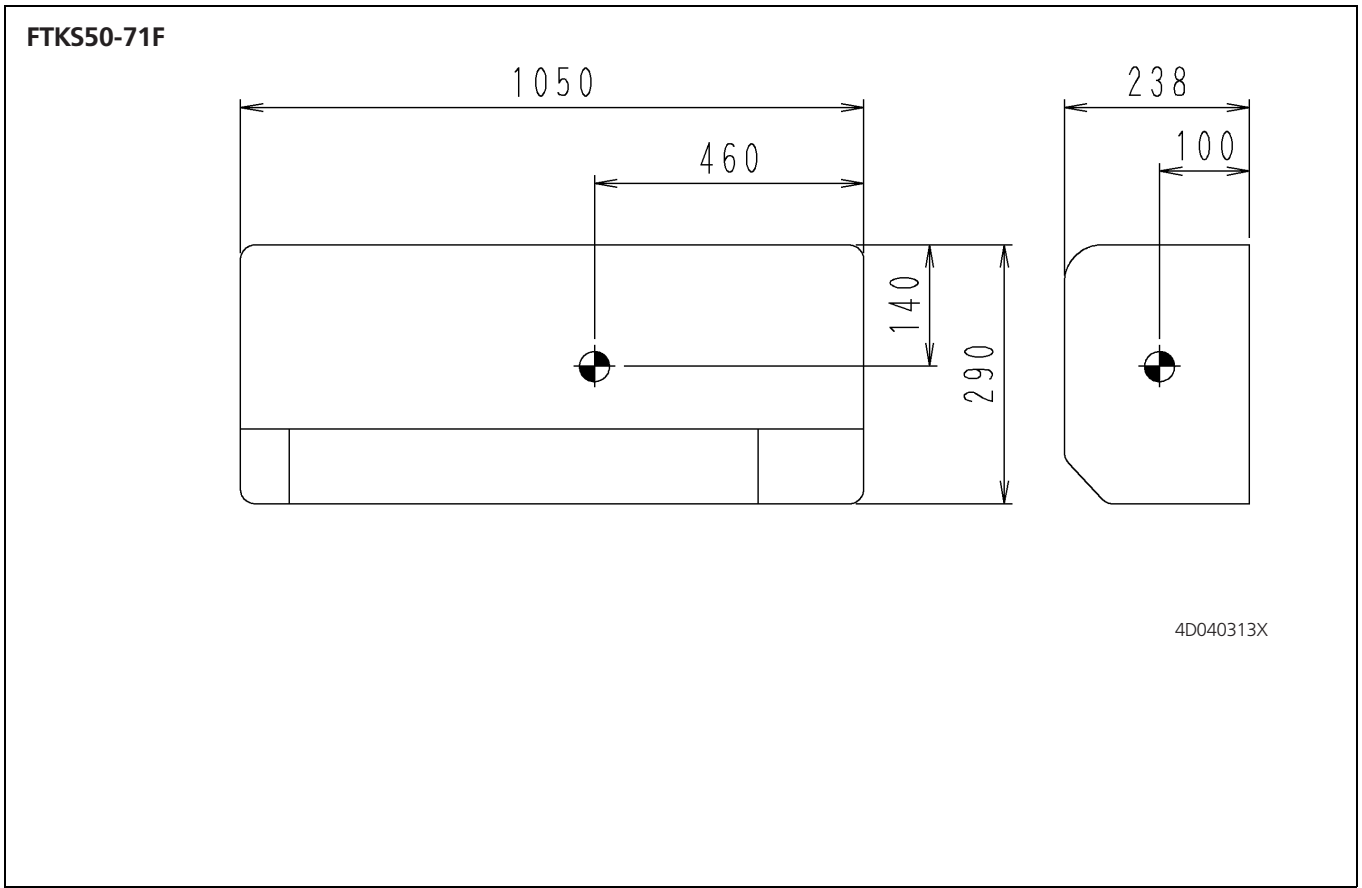

unit (mm)

3D055868

### 3 Dimensional drawing & centre of gravity

#### 3 - 2 Centre of gravity



## 4 Piping diagram

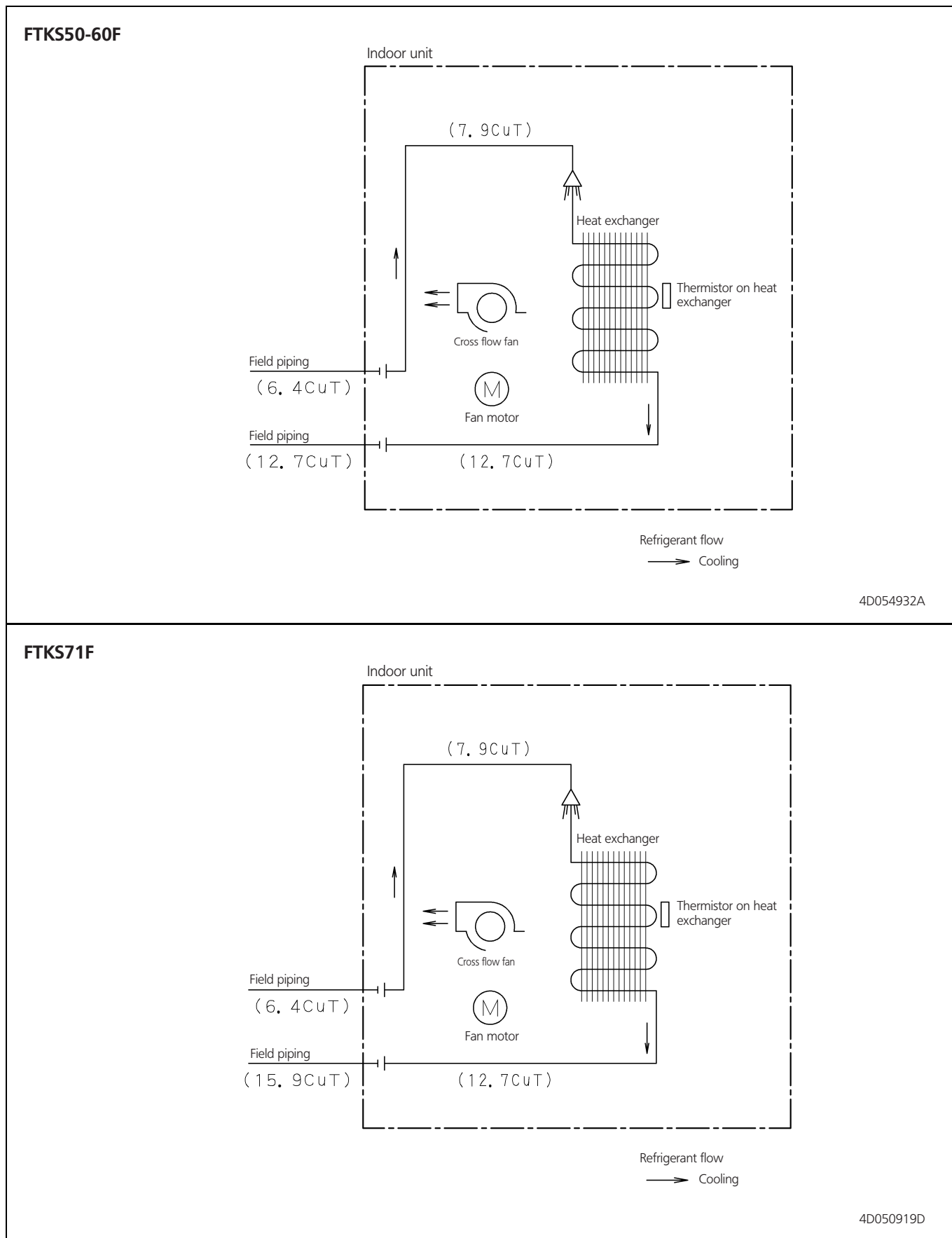

# 5 Wiring diagram

## 5 - 1 Wiring diagram

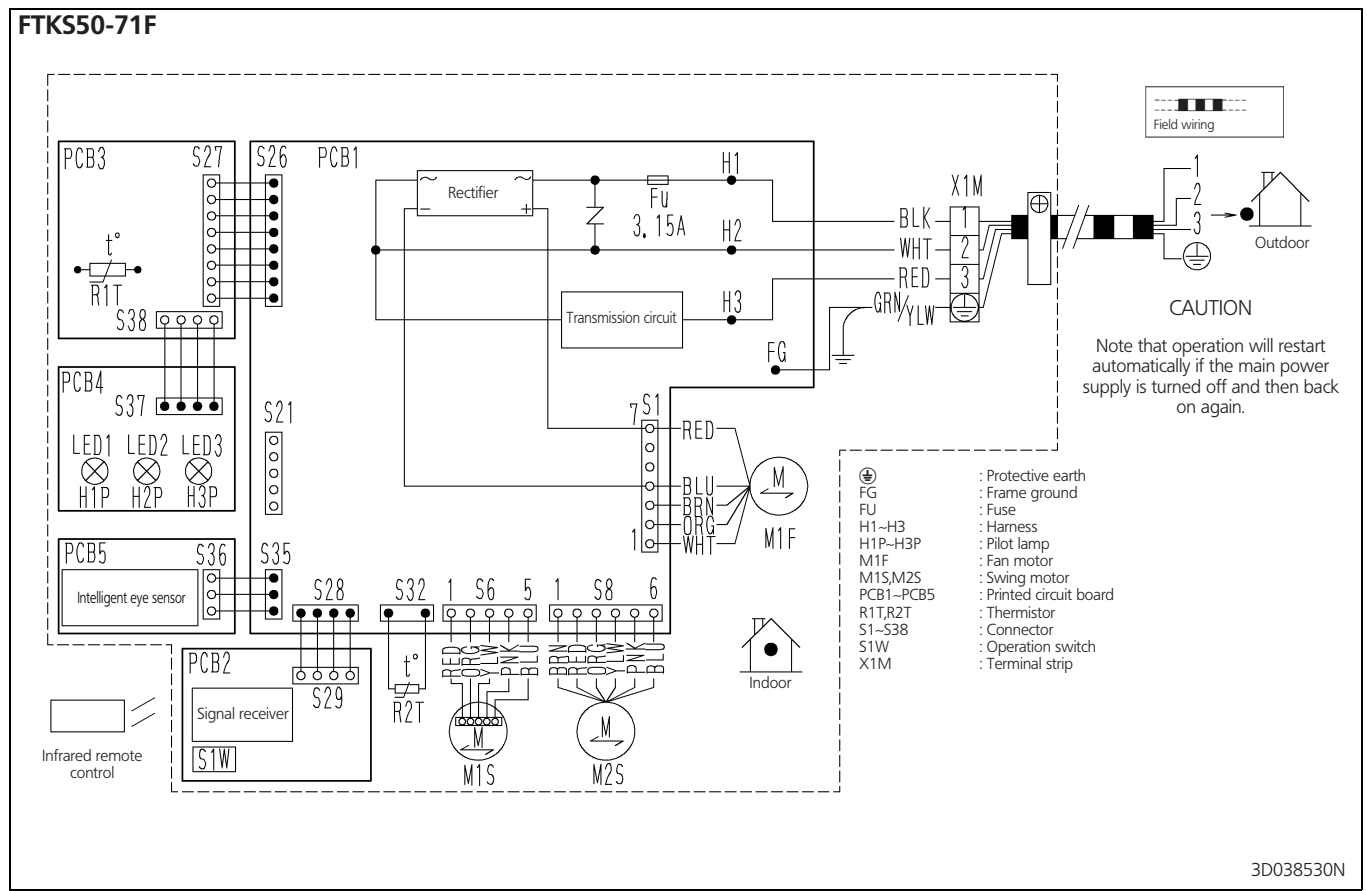

# 6 Sound data

## 6 - 1 Sound pressure spectrum

