

Service Manual

Inverter Pair Floor / Ceiling Suspended Dual Type B-Series



[Applied Models]

- Inverter Pair : Cooling Only
- Inverter Pair : Heat Pump

Inverter Pair B-Series

●Cooling Only

Indoor Unit

**FLKS25BVMB
FLKS35BVMB**

**FLKS25BAVMB
FLKS35BAVMB**

Outdoor Unit

**RKS25DVMB
RKS35DVMB**

**RKS25D2VMB
RKS35D2VMB**

**RKS25D3VMB
RKS35D3VMB**

●Heat Pump

Indoor Unit

**FLXS25BVMB
FLXS35BVMB**

**FLXS25BAVMB
FLXS35BAVMB**

Outdoor Unit

**RXS25DVMB
RXS35DVMB**

**RXS25D2VMB
RXS35D2VMB**

**RXS25D3VMB
RXS35D3VMB**

1. Introduction	V
1.1 Safety Cautions	V
Part 1 List of Functions	1
1. List of Functions	2
Part 2 Specifications	5
1. Specifications	6
1.1 Cooling Only	6
1.2 Heat Pump	8
Part 3 Printed Circuit Board Connector Wiring Diagram	11
1. Printed Circuit Board Connector Wiring Diagram	12
1.1 Indoor Unit	12
1.2 Outdoor Unit	14
Part 4 Function and Control	17
1. Main Functions	18
1.1 Frequency Principle	18
1.2 Auto-Swing	20
1.3 Fan Speed Control for Indoor Units	21
1.4 Programme Dry Function	22
1.5 Automatic Operation	23
1.6 Thermostat Control	24
1.7 NIGHT SET Mode	25
1.8 HOME LEAVE Operation	26
1.9 Inverter POWERFUL Operation	27
1.10 Other Functions	28
2. Function of Thermistor	29
2.1 Heat Pump Model	29
2.2 Cooling Only Model	30
3. Control Specification	31
3.1 Mode Hierarchy	31
3.2 Frequency Control	32
3.3 Controls at Mode Changing / Start-up	34
3.4 Discharge Pipe Control	35
3.5 Input Current Control	36
3.6 Freeze-up Protection Control	37
3.7 Heating Peak-cut Control	37
3.8 Fan Control	38
3.9 Liquid Compression Protection Function 2	38
3.10 Defrost Control	39
3.11 Electronic Expansion Valve Control	40
3.12 Malfunctions	43
3.13 Forced Operation Mode	44
3.14 Additional Function	44
3.15 Facility Setting Jumper (cooling at low outdoor temperature)	45





Part 5 System Configuration.....	47
1. System Configuration.....	48
2. Instruction.....	49
2.1 Safety precautions.....	49
2.2 Names of parts.....	51
2.3 Preparation before Operation.....	54
2.4 AUTO · DRY · COOL · HEAT · FAN Operation.....	57
2.5 Adjusting the Air Flow Direction.....	59
2.6 POWERFUL Operation.....	61
2.7 OUTDOOR UNIT SILENT Operation.....	62
2.8 HOME LEAVE Operation.....	63
2.9 TIMER Operation.....	65
2.10 Care and Cleaning.....	67
2.11 Troubleshooting.....	70
Part 6 Service Diagnosis.....	75
1. Caution for Diagnosis.....	76
2. Problem Symptoms and Measures.....	77
3. Service Check Function.....	78
4. Troubleshooting.....	81
4.1 Error Codes and Description.....	81
4.2 Indoor Unit PCB Abnormality.....	82
4.3 Freeze-up Protection Control or High Pressure Control.....	83
4.4 Fan Motor (AC Motor) or Related Abnormality.....	85
4.5 Thermistor or Related Abnormality (Indoor Unit).....	86
4.6 Signal Transmission Error (between Indoor and Outdoor Unit).....	87
4.7 Unspecified Voltage (between Indoor and Outdoor Units).....	88
4.8 Outdoor Unit PCB Abnormality.....	89
4.9 OL Activation (Compressor Overload).....	90
4.10 Compressor Lock.....	91
4.11 DC Fan Lock.....	92
4.12 Input Over Current Detection.....	93
4.13 Four Way Valve Abnormality.....	94
4.14 Discharge Pipe Temperature Control.....	96
4.15 High Pressure Control in Cooling.....	97
4.16 Compressor System Sensor Abnormality.....	99
4.17 Position Sensor Abnormality.....	100
4.18 DC Voltage / Current Sensor Abnormality.....	101
4.19 Thermistor or Related Abnormality (Outdoor Unit).....	102
4.20 Electrical Box Temperature Rise.....	104
4.21 Radiation Fin Temperature Rise.....	106
4.22 Output Over Current Detection.....	108
4.23 Insufficient Gas.....	110
4.24 Over-voltage Detection.....	112
5. Check.....	113
5.1 How to Check.....	113

Part 7 Removal Procedure	121
1. Indoor Unit.....	122
1.1 Removal of the Air Filter / Front Grille	122
1.2 Removal of the Front Panel.....	125
1.3 Removal of the Horizontal Blade.....	127
1.4 Removal of the Signal Receiver Unit / Swing Motor.....	128
1.5 Removal of the Discharge Grille.....	129
1.6 Removal of the Drain Pan	130
1.7 Removal of the Electrical Box / PCB.....	131
1.8 Removal of the Fan Rotor / Fan Motor.....	134
1.9 Removal of the Heat Exchanger	136
2. Outdoor Unit.....	138
2.1 Removal of Panels and Fan Motor.....	138
2.2 Removal of Electrical Box	145
2.3 Removal of Reactor and Partition Plate	147
2.4 Removal of Sound Blanket.....	149
2.5 Removal of Four Way Valve.....	151
2.6 Removal of Compressor.....	153
2.7 Removal of PCB.....	155
Part 8 Others	159
1. Others	160
1.1 Test Run from the Remote Controller	160
1.2 Jumper Settings	161
Part 9 Appendix.....	163
1. Piping Diagrams.....	164
1.1 Indoor Units	164
1.2 Outdoor Units	165
2. Wiring Diagrams.....	167
2.1 Indoor Units	167
2.2 Outdoor Units	167
Index	i
Drawings & Flow Charts	v







1. Introduction







1.1 Safety Cautions

Cautions and Warnings

- Be sure to read the following safety cautions before conducting repair work.
- The caution items are classified into “ **Warning**” and “ **Caution**”. The “ **Warning**” items are especially important since they can lead to death or serious injury if they are not followed closely. The “ **Caution**” items can also lead to serious accidents under some conditions if they are not followed. Therefore, be sure to observe all the safety caution items described below.
- About the pictograms
 - △ This symbol indicates an item for which caution must be exercised.
The pictogram shows the item to which attention must be paid.
 - This symbol indicates a prohibited action.
The prohibited item or action is shown inside or near the symbol.
 - This symbol indicates an action that must be taken, or an instruction.
The instruction is shown inside or near the symbol.
- After the repair work is complete, be sure to conduct a test operation to ensure that the equipment operates normally, and explain the cautions for operating the product to the customer.



1.1.1 Caution in Repair



 Warning	
<p>Be sure to disconnect the power cable plug from the plug socket before disassembling the equipment for a repair. Working on the equipment that is connected to a power supply can cause an electrical shock. If it is necessary to supply power to the equipment to conduct the repair or inspecting the circuits, do not touch any electrically charged sections of the equipment.</p>	
<p>If the refrigerant gas discharges during the repair work, do not touch the discharging refrigerant gas. The refrigerant gas can cause frostbite.</p>	
<p>When disconnecting the suction or discharge pipe of the compressor at the welded section, release the refrigerant gas completely at a well-ventilated place first. If there is a gas remaining inside the compressor, the refrigerant gas or refrigerating machine oil discharges when the pipe is disconnected, and it can cause injury.</p>	
<p>If the refrigerant gas leaks during the repair work, ventilate the area. The refrigerant gas can generate toxic gases when it contacts flames.</p>	
<p>The step-up capacitor supplies high-voltage electricity to the electrical components of the outdoor unit. Be sure to discharge the capacitor completely before conducting repair work. A charged capacitor can cause an electrical shock.</p>	
<p>Do not start or stop the air conditioner operation by plugging or unplugging the power cable plug. Plugging or unplugging the power cable plug to operate the equipment can cause an electrical shock or fire.</p>	

 Warning	
Do not repair the electrical components with wet hands. Working on the equipment with wet hands can cause an electrical shock.	
Do not clean the air conditioner by splashing water. Washing the unit with water can cause an electrical shock.	
Be sure to provide the grounding when repairing the equipment in a humid or wet place, to avoid electrical shocks.	
Be sure to turn off the power switch and unplug the power cable when cleaning the equipment. The internal fan rotates at a high speed, and cause injury.	
Do not tilt the unit when removing it. The water inside the unit can spill and wet the furniture and floor.	
Be sure to check that the refrigerating cycle section has cooled down sufficiently before conducting repair work. Working on the unit when the refrigerating cycle section is hot can cause burns.	
Use the welder in a well-ventilated place. Using the welder in an enclosed room can cause oxygen deficiency.	



1.1.2 Cautions Regarding Products after Repair



 Warning	
Be sure to use parts listed in the service parts list of the applicable model and appropriate tools to conduct repair work. Never attempt to modify the equipment. The use of inappropriate parts or tools can cause an electrical shock, excessive heat generation or fire.	
When relocating the equipment, make sure that the new installation site has sufficient strength to withstand the weight of the equipment. If the installation site does not have sufficient strength and if the installation work is not conducted securely, the equipment can fall and cause injury.	
Be sure to install the product correctly by using the provided standard installation frame. Incorrect use of the installation frame and improper installation can cause the equipment to fall, resulting in injury.	For integral units only
Be sure to install the product securely in the installation frame mounted on a window frame. If the unit is not securely mounted, it can fall and cause injury.	For integral units only
Be sure to use an exclusive power circuit for the equipment, and follow the technical standards related to the electrical equipment, the internal wiring regulations and the instruction manual for installation when conducting electrical work. Insufficient power circuit capacity and improper electrical work can cause an electrical shock or fire.	



 Warning	
Be sure to use the specified cable to connect between the indoor and outdoor units. Make the connections securely and route the cable properly so that there is no force pulling the cable at the connection terminals. Improper connections can cause excessive heat generation or fire.	
When connecting the cable between the indoor and outdoor units, make sure that the terminal cover does not lift off or dismount because of the cable. If the cover is not mounted properly, the terminal connection section can cause an electrical shock, excessive heat generation or fire.	
Do not damage or modify the power cable. Damaged or modified power cable can cause an electrical shock or fire. Placing heavy items on the power cable, and heating or pulling the power cable can damage the cable.	
Do not mix air or gas other than the specified refrigerant (R-410A / R22) in the refrigerant system. If air enters the refrigerating system, an excessively high pressure results, causing equipment damage and injury.	
If the refrigerant gas leaks, be sure to locate the leak and repair it before charging the refrigerant. After charging refrigerant, make sure that there is no refrigerant leak. If the leak cannot be located and the repair work must be stopped, be sure to perform pump-down and close the service valve, to prevent the refrigerant gas from leaking into the room. The refrigerant gas itself is harmless, but it can generate toxic gases when it contacts flames, such as fan and other heaters, stoves and ranges.	
When replacing the coin battery in the remote controller, be sure to disposed of the old battery to prevent children from swallowing it. If a child swallows the coin battery, see a doctor immediately.	

 Caution	
Installation of a leakage breaker is necessary in some cases depending on the conditions of the installation site, to prevent electrical shocks.	
Do not install the equipment in a place where there is a possibility of combustible gas leaks. If a combustible gas leaks and remains around the unit, it can cause a fire.	
Be sure to install the packing and seal on the installation frame properly. If the packing and seal are not installed properly, water can enter the room and wet the furniture and floor.	For integral units only

1.1.3 Inspection after Repair

 Warning	
Check to make sure that the power cable plug is not dirty or loose, then insert the plug into a power outlet all the way. If the plug has dust or loose connection, it can cause an electrical shock or fire.	
If the power cable and lead wires have scratches or deteriorated, be sure to replace them. Damaged cable and wires can cause an electrical shock, excessive heat generation or fire.	





 Warning	
Do not use a joined power cable or extension cable, or share the same power outlet with other electrical appliances, since it can cause an electrical shock, excessive heat generation or fire.	

 Caution	
Check to see if the parts and wires are mounted and connected properly, and if the connections at the soldered or crimped terminals are secure. Improper installation and connections can cause excessive heat generation, fire or an electrical shock.	
If the installation platform or frame has corroded, replace it. Corroded installation platform or frame can cause the unit to fall, resulting in injury.	
Check the grounding, and repair it if the equipment is not properly grounded. Improper grounding can cause an electrical shock.	
Be sure to measure the insulation resistance after the repair, and make sure that the resistance is 1 Mohm or higher. Faulty insulation can cause an electrical shock.	
Be sure to check the drainage of the indoor unit after the repair. Faulty drainage can cause the water to enter the room and wet the furniture and floor.	

1.1.4 Using Icons

Icons are used to attract the attention of the reader to specific information. The meaning of each icon is described in the table below:

1.1.5 Using Icons List

Icon	Type of Information	Description
 Note:	Note	A “note” provides information that is not indispensable, but may nevertheless be valuable to the reader, such as tips and tricks.
 Caution	Caution	A “caution” is used when there is danger that the reader, through incorrect manipulation, may damage equipment, lose data, get an unexpected result or has to restart (part of) a procedure.
 Warning	Warning	A “warning” is used when there is danger of personal injury.
	Reference	A “reference” guides the reader to other places in this binder or in this manual, where he/she will find additional information on a specific topic.

Part 1

List of Functions

1. List of Functions2

1. List of Functions

Category	Functions	FLKS25-35B/VMB RKS25-35D(2)/VMB	FLXS25-35B/VMB RXS25-35D(2)/VMB	Category	Functions	FLKS25-35B/VMB RKS25-35D(2)/VMB	FLXS25-35B/VMB RXS25-35D(2)/VMB	
Basic Function	Inverter (with Inverter Power Control)	○	○	Health & Clean	Air Purifying Filter with Bacteriostatic, Virustatic Functions	○	○	
	Operation Limit for Cooling (°CDB) ★1	-10 ~46	-10 ~46		Photocatalytic Deodorizing Filter	○	○	
	Operation Limit for Heating (°CWB)	—	-15 ~20		Air Purifying Filter with Photocatalytic Deodorizing Function	—	—	
	PAM Control	○	○		Longlife Filter	—	—	
Compressor	Oval Scroll Compressor	—	—		Ultra-Longlife Filter (Option)	—	—	
	Swing Compressor	○	○		Mold Proof Air Filter	○	○	
	Rotary Compressor	—	—		Wipe-clean Flat Panel	—	—	
	Reluctance DC Motor	○	○		Washable Grille	—	—	
Comfortable Airflow	Power-Airflow Flap	—	—		Mold Proof Operation	—	—	
	Power-Airflow Dual Flaps	—	—		Heating Dry Operation	—	—	
	Power-Airflow Diffuser	—	—		Filter Cleaning Indicator	—	—	
	Wide-Angle Louvers	—	—		Good-Sleep Cooling Operation	—	—	
	Vertical Auto-Swing (Up and Down)	○	○		Timer	24-Hour On/Off Timer	○	○
	Horizontal Auto-Swing (Right and Left)	—	—			Night Set Mode	○	○
	3-D Airflow	—	—		Worry Free "Reliability & Durability"	Auto-Restart (after Power Failure)	○	○
3-Step Airflow (H/P Only)	—	—	Self-Diagnosis (Digital, LED) Display			○ ★2	○ ★2	
Auto Fan Speed	○	○	Wiring Error Check	—		—		
Comfort Control	Indoor Unit Silent Operation	○	○	Flexibility	Anticorrosion Treatment of Outdoor Heat Exchanger	○	○	
	Night Quiet Mode (Automatic)	—	—		Multi-Split / Split Type Compatible Indoor Unit	○	○	
	Outdoor Unit Silent Operation (Manual)	○	○		Flexible Voltage Correspondence	○	○	
	Intelligent Eye	—	—		High Ceiling Application	—	—	
	Quick Warming Function	—	○		Chargeless	10m	10m	
	Hot-Start Function	—	○		Power Selection	—	—	
	Automatic Defrosting	—	○		Remote Control	5-Rooms Centralized Controller (Option)	○	○
Automatic Operation	—	○	Remote Control Adaptor (Normal Open-Pulse Contact)(Option)	○		○		
Programme Dry Function	○	○	Remote Control Adaptor (Normal Open Contact)(Option)	○		○		
Fan Only	○	○	DIII-NET Compatible (Adaptor)(Option)	○		○		
Lifestyle Convenience	New Powerful Operation (Non-Inverter)	—	—	Remote Controller	Wireless	○	○	
	Inverter Powerful Operation	○	○		Wired	—	—	
	Priority-Room Setting	—	—					
	Cooling / Heating Mode Lock	—	—					
	Home Leave Operation	○	○					
	ECONO Mode	—	—					
	Indoor Unit On/Off Switch	○	○					
	Signal Reception Indicator	○	○					
Temperature Display	—	—						
Another Room Operation	—	—						

Note: ○ : Holding Functions
— : No Functions

★1 : Lower limit can be extended to -15°C by cutting jumper. (facility use only)
★2 : Digital Only

Category	Functions	FLKS25-35BAVMB RKS25-35D3VMB	FLXS25-35BAVMB RXS25-35D3VMB	Category	Functions	FLKS25-35BAVMB RKS25-35D3VMB	FLXS25-35BAVMB RXS25-35D3VMB
Basic Function	Inverter (with Inverter Power Control)	○	○		Air Purifying Filter with Bacteriostatic, Virustatic Functions	○	○
	Operation Limit for Cooling (°CDB) ★1	-10 ~46	-10 ~46		Photocatalytic Deodorizing Filter	○	○
	Operation Limit for Heating (°CWB)	—	-15 ~20		Air Purifying Filter with Photocatalytic Deodorizing Function	—	—
	PAM Control	○	○		Longlife Filter	—	—
Compressor	Oval Scroll Compressor	—	—	Health & Clean	Ultra-Longlife Filter (Option)	—	—
	Swing Compressor	○	○		Mold Proof Air Filter	○	○
	Rotary Compressor	—	—		Wipe-clean Flat Panel	—	—
	Reluctance DC Motor	○	○		Washable Grille	—	—
Comfortable Airflow	Power-Airflow Flap	—	—	Timer	Mold Proof Operation	—	—
	Power-Airflow Dual Flaps	—	—		Heating Dry Operation	—	—
	Power-Airflow Diffuser	—	—		Filter Cleaning Indicator	—	—
	Wide-Angle Louvers	—	—		Good-Sleep Cooling Operation	—	—
	Vertical Auto-Swing (Up and Down)	○	○		24-Hour On/Off Timer	○	○
	Horizontal Auto-Swing (Right and Left)	—	—		Night Set Mode	○	○
	3-D Airflow	—	—		Worry Free "Reliability & Durability"	Auto-Restart (after Power Failure)	○
3-Step Airflow (H/P Only)	—	—	Self-Diagnosis (Digital, LED) Display	○ ★2		○ ★2	
Comfort Control	Auto Fan Speed	○	○	Flexibility	Wiring Error Check	—	—
	Indoor Unit Silent Operation	○	○		Anticorrosion Treatment of Outdoor Heat Exchanger	○	○
	Night Quiet Mode (Automatic)	—	—		Multi-Split / Split Type Compatible Indoor Unit	○	○
	Outdoor Unit Silent Operation (Manual)	○	○		Flexible Voltage Correspondence	○	○
	Intelligent Eye	—	—		High Ceiling Application	—	—
	Quick Warming Function	—	○		Chargeless	10m	10m
	Hot-Start Function	—	○		Power Selection	—	—
Operation	Automatic Operation	—	○	Remote Control	5-Rooms Centralized Controller (Option)	○	○
	Programme Dry Function	○	○		Remote Control Adaptor (Normal Open-Pulse Contact)(Option)	○	○
	Fan Only	○	○		Remote Control Adaptor (Normal Open Contact)(Option)	○	○
Lifestyle Convenience	New Powerful Operation (Non-Inverter)	—	—	Remote Controller	DIII-NET Compatible (Adaptor)(Option)	○	○
	Inverter Powerful Operation	○	○		Wireless	○	○
	Priority-Room Setting	—	—	Wired	—	—	
	Cooling / Heating Mode Lock	—	—				
	Home Leave Operation	○	○				
	ECONO Mode	—	—				
	Indoor Unit On/Off Switch	○	○				
	Signal Reception Indicator	○	○				
Temperature Display	—	—					
Another Room Operation	—	—					

Note: ○ : Holding Functions
— : No Functions

★1 : Lower limit can be extended to -15°C by cutting jumper. (facility use only)
★2 : Digital Only

Part 2

Specifications

1. Specifications	6
1.1 Cooling Only	6
1.2 Heat Pump	8

1. Specifications

1.1 Cooling Only

50Hz 230V

Model	Indoor Units		FLKS25BVMB		FLKS35BVMB	
	Outdoor Units		RKS25D(2)VMB		RKS35D(2)VMB	
Capacity Rated (Min.-Max.)			kW	2.5 (1.3-3.0)	3.5 (1.4-3.8)	
			Btu/h	8,500 (4,400-10,200)	11,900 (4,750-12,950)	
			kcal/h	2,150 (1,110-2,580)	3,010 (1,200-3,260)	
Moisture Removal			L/h	1.2	1.9	
Running Current (Rated)			A	4.3	5.3	
Power Consumption Rated (Min.-Max.)			W	780 (300-960)	1,160 (300-1,270)	
Power Factor			%	78.9	95.2	
COP			W/W	3.21	3.02	
Piping Connections	Liquid	mm	φ 6.4	φ 6.4		
	Gas	mm	φ 9.5	φ 9.5		
	Drain	mm	φ 18.0	φ 18.0		
Heat Insulation	Both Liquid and Gas Pipes				Both Liquid and Gas Pipes	
Indoor Unit			FLKS25BVMB		FLKS35BVMB	
Front Panel Color			Almond White		Almond White	
Air Flow Rate	m ³ /min (cfm)	H	7.6 (268)	8.6 (304)		
		M	6.8 (240)	7.6 (268)		
		L	6.0 (212)	6.6 (233)		
		SL	5.2 (184)	5.6 (198)		
Fan	Type	Sirocco Fan		Sirocco Fan		
	Motor Output	W	34	34		
	Speed	Steps	5 Steps, Silent, Auto	5 Steps, Silent, Auto		
Air Direction Control			Right, Left, Horizontal, Downward		Right, Left, Horizontal, Downward	
Air Filter			Removable/Washable/Mildew Proof		Removable/Washable/Mildew Proof	
Running Current (Rated)			A	0.34	0.36	
Power Consumption (Rated)			W	74	78	
Power Factor			%	94.6	94.2	
Temperature Control			Microcomputer Control		Microcomputer Control	
Dimensions (HxWxD)	mm		490x1,050x200		490x1,050x200	
Packaged Dimensions(HxWxD)	mm		566x1,100x280		566x1,100x280	
Weight	kg		16		16	
Gross Weight	kg		22		22	
Operation Sound	H/M/L/SL	dBA	37/34/31/28		38/35/32/29	
Sound Power	H	dBA	53		54	
Outdoor Unit			RKS25D(2)VMB		RKS35D(2)VMB	
Casing Color			Ivory White		Ivory White	
Compressor	Type	Hermetically Sealed Swing Type		Hermetically Sealed Swing Type		
	Model	1YC23NXD#A		1YC23NXD#A		
	Motor Output	W	600	600		
Refrigerant Oil	Type	FVC50K		FVC50K		
	Charge	L	0.375	0.375		
Refrigerant	Type	R-410A		R-410A		
	Charge	kg	0.80	1.00		
Air Flow Rate	m ³ /min (cfm)	H	36.2 (1,278)	33.5 (1,183)		
		L	25.7 (907)	23.4 (826)		
Fan	Type	Propeller		Propeller		
	Motor Output	W	31	35		
Running Current (Rated)			A	3.96	4.94	
Power Consumption (Rated)			W	706	1,082	
Power Factor			%	77.5	95.2	
Starting Current			A	4.3	5.3	
Dimensions (HxWxD)	mm		550x765x285		550x765x285	
Packaged Dimensions(HxWxD)	mm		589x882x363		589x882x363	
Weight	kg		30		32	
Gross Weight	kg		35		38	
Operation Sound	H/L	dBA	46/43		47/44	
Sound Power	H	dBA	61		62	
Drawing No.			3D049141		3D049142	

- Note:**
- MAX. interunit piping length: 20m
 - MAX. interunit height difference: 15m
 - Amount of additional charge of refrigerant 20g/m for piping length exceeding 10m
 - The data are based on the conditions shown in the table below.

Cooling	Piping Length
Indoor ; 27°CDB/19°CWB Outdoor ; 35°CDB/24°CWB	7.5m

Conversion Formulae
kcal/h=kWx860 Btu/h=kWx3414 cfm=m ³ /minx35.3

50Hz 230V

Model	Indoor Units		FLKS25BAVMB		FLKS35BAVMB	
	Outdoor Units		RKS25D3VMB		RKS35D3VMB	
Capacity Rated (Min.-Max.)	kW		2.5 (1.3-3.0)		3.5 (1.4-3.8)	
	Btu/h		8,500 (4,400-10,200)		11,900 (4,750-12,950)	
	kcal/h		2,150 (1,110-2,580)		3,010 (1,200-3,260)	
Moisture Removal	L/h		1.2		1.9	
Running Current (Rated)	A		4.3		5.3	
Power Consumption Rated (Min.-Max.)	W		780 (300-960)		1,160 (300-1,270)	
Power Factor	%		78.9		95.2	
COP	W/W		3.21		3.02	
Piping Connections	Liquid	mm	φ 6.4		φ 6.4	
	Gas	mm	φ 9.5		φ 9.5	
	Drain	mm	φ 18.0		φ 18.0	
Heat Insulation			Both Liquid and Gas Pipes		Both Liquid and Gas Pipes	
Indoor Unit			FLKS25BAVMB		FLKS35BAVMB	
Front Panel Color			Almond White		Almond White	
Air Flow Rate	m ³ /min (cfm)	H	7.6 (268)		8.6 (304)	
		M	6.8 (240)		7.6 (268)	
		L	6.0 (212)		6.6 (233)	
		SL	5.2 (184)		5.6 (198)	
Fan	Type	Sirocco Fan		Sirocco Fan		
	Motor Output	W	34		34	
	Speed	Steps	5 Steps, Silent, Auto		5 Steps, Silent, Auto	
Air Direction Control			Right, Left, Horizontal, Downward		Right, Left, Horizontal, Downward	
Air Filter			Removable/Washable/Mildew Proof		Removable/Washable/Mildew Proof	
Running Current (Rated)	A	0.34		0.36		
Power Consumption (Rated)	W	74		78		
Power Factor	%	94.6		94.2		
Temperature Control			Microcomputer Control		Microcomputer Control	
Dimensions (HxWxD)	mm	490x1,050x200		490x1,050x200		
Packaged Dimensions(HxWxD)	mm	566x1,100x280		566x1,100x280		
Weight	kg	16		16		
Gross Weight	kg	22		22		
Operation Sound	H/M/L/SL	dBA	37/34/31/28		38/35/32/29	
Sound Power	H	dBA	53		54	
Outdoor Unit			RKS25D3VMB		RKS35D3VMB	
Casing Color			Ivory White		Ivory White	
Compressor	Type	Hermetically Sealed Swing Type		Hermetically Sealed Swing Type		
	Model	1YC23NXD#A		1YC23NXD#A		
	Motor Output	W	600		600	
Refrigerant Oil	Type	FVC50K		FVC50K		
	Charge	L	0.375		0.375	
Refrigerant	Type	R-410A		R-410A		
	Charge	kg	0.80		1.00	
Air Flow Rate	m ³ /min (cfm)	H	36.2 (1,278)		33.5 (1,183)	
		L	25.7 (907)		23.4 (826)	
Fan	Type	Propeller		Propeller		
	Motor Output	W	31		35	
Running Current (Rated)	A	3.96		4.94		
Power Consumption (Rated)	W	706		1,082		
Power Factor	%	77.5		95.2		
Starting Current	A	4.3		5.3		
Dimensions (HxWxD)	mm	550x765x285		550x765x285		
Packaged Dimensions(HxWxD)	mm	589x882x363		589x882x363		
Weight	kg	30		32		
Gross Weight	kg	35		38		
Operation Sound	H/L	dBA	46/43		47/44	
Sound Power	H	dBA	61		62	
Drawing No.			3D050862		3D050864	

Note:

- MAX. interunit piping length: 20m
- MAX. interunit height difference: 15m
- Amount of additional charge of refrigerant 20g/m for piping length exceeding 10m
- The data are based on the conditions shown in the table below.

Cooling	Piping Length
Indoor ; 27°CDB/19°CWB Outdoor ; 35°CDB/24°CWB	7.5m

Conversion Formulae
kcal/h=kWx860 Btu/h=kWx3414 cfm=m ³ /minx35.3

1.2 Heat Pump

50Hz 230V

Model	Indoor Units		FLXS25BVMB		FLXS35BVMB	
	Outdoor Units		RXS25D(2)VMB		RXS35D(2)VMB	
			Cooling	Heating	Cooling	Heating
Capacity Rated (Min.~Max.)	kW		2.5 (1.3~3.0)	3.4 (1.3~4.5)	3.5 (1.4~3.8)	4.0 (1.4~5.0)
	Btu/h		8,500 (4,400~10,200)	11,600 (4,400~15,350)	11,900 (4,750~12,950)	13,650 (4,750~17,050)
	kcal/h		2,150 (1,110~2,580)	2,920 (1,110~3,870)	3,010 (1,200~3,260)	3,440 (1,200~4,300)
Moisture Removal	L/h		1.2	—	1.9	—
Running Current (Rated)	A		4.3	4.6	5.3	5.7
Power Consumption Rated (Min.~Max.)	W		780 (300~960)	995 (290~1,500)	1,160 (300~1,270)	1,245 (310~1,860)
Power Factor	%		78.9	94.0	95.2	95.0
COP	W/W		3.21	3.42	3.02	3.21
Piping Connections	Liquid	mm	φ 6.4		φ 6.4	
	Gas	mm	φ 9.5		φ 9.5	
	Drain	mm	φ 18.0		φ 18.0	
Heat Insulation			Both Liquid and Gas Pipes		Both Liquid and Gas Pipes	
Indoor Unit		FLXS25BVMB		FLXS35BVMB		
Front Panel Color		Almond White		Almond White		
Air Flow Rate	m³/min (cfm)	H	7.6 (268)	9.2 (325)	8.6 (304)	9.8 (346)
		M	6.8 (240)	8.3 (293)	7.6 (268)	8.9 (314)
		L	6.0 (212)	7.4 (261)	6.6 (233)	8.0 (282)
		SL	5.2 (184)	6.6 (233)	5.6 (198)	7.2 (254)
Fan	Type	Sirocco Fan		Sirocco Fan		
	Motor Output	W	34		34	
	Speed	Steps	5 Steps, Silent, Auto		5 Steps, Silent, Auto	
Air Direction Control			Right, Left, Horizontal, Downward		Right, Left, Horizontal, Downward	
Air Filter			Removable / Washable / Mildew Proof		Removable / Washable / Mildew Proof	
Running Current (Rated)	A		0.32	0.34	0.36	0.36
Power Consumption (Rated)	W		70	74	78	78
Power Factor	%		95.1	94.6	94.2	94.2
Temperature Control			Microcomputer Control		Microcomputer Control	
Dimensions (HxWxD)	mm		490x1,050x200		490x1,050x200	
Packaged Dimensions (HxWxD)	mm		566x1,100x280		566x1,100x280	
Weight	kg		16		16	
Gross Weight	kg		22		22	
Operation Sound	H/M/L/SL	dBA	37/34/31/28	37/34/31/29	38/35/32/29	39/36/33/30
Sound Power	H	dBA	53	—	54	—
Outdoor Unit		RXS25D(2)VMB		RXS35D(2)VMB		
Casing Color		Ivory White		Ivory White		
Compressor	Type	Hermetically Sealed Swing Type		Hermetically Sealed Swing Type		
	Model	1YC23NXD#A		1YC23NXD#A		
	Motor Output	W	600		600	
Refrigerant Oil	Model	FVC50K		FVC50K		
	Charge	L	0.375		0.375	
Refrigerant	Model	R-410A		R-410A		
	Charge	kg	0.8		1.00	
Air Flow Rate	m³/min (cfm)	H	36.2(1,278)	32.6(1,151)	33.5(1,183)	30.2(1,066)
		L	25.7(907)	30.6(1,080)	23.4(826)	28.3(999)
Fan	Type	Propeller		Propeller		
	Motor Output	W	31		35	
Running Current (Rated)	A		3.98	4.26	4.94	5.34
Power Consumption (Rated)	W		710	921	1,082	1,167
Power Factor	%		77.6	94.0	95.2	95.0
Starting Current	A		4.6		5.7	
Dimensions (HxWxD)	mm		550x765x285		550x765x285	
Packaged Dimensions (HxWxD)	mm		589x882x363		589x882x363	
Weight	kg		30		32	
Gross Weight	kg		35		38	
Operation Sound	H/L	dBA	46/43	47/44	47/44	48/45
Sound Power	H	dBA	61	62	62	63
Drawing No.			3D049143		3D049144	

- Note:**
- MAX. interunit piping length: 20m
 - MAX. interunit height difference: 15m
 - Amount of additional charge of refrigerant 20g/m for piping length exceeding 10m
 - The data are based on the conditions shown in the table below.

Cooling	Heating	Piping Length
Indoor ; 27°CDB/19°CWB Outdoor ; 35°CDB/24°CWB	Indoor ; 20°CDB Outdoor ; 7°CDB/6°CWB	7.5m

Conversion Formulae
kcal/h=kWx860 Btu/h=kWx3414 cfm=m³/minx35.3

50Hz 230V

Model	Indoor Units		FLXS25BAVMB		FLXS35BAVMB	
	Outdoor Units		RXS25D3VMB		RXS35D3VMB	
			Cooling	Heating	Cooling	Heating
Capacity Rated (Min.-Max.)	kW		2.5 (1.3~3.0)	3.4 (1.3~4.5)	3.5 (1.4~3.8)	4.0 (1.4~5.0)
	Btu/h		8,500 (4,400~10,200)	11,600 (4,400~15,350)	11,900 (4,750~12,950)	13,650 (4,750~17,050)
	kcal/h		2,150 (1,110~2,580)	2,920 (1,110~3,870)	3,010 (1,200~3,260)	3,440 (1,200~4,300)
Moisture Removal	L/h		1.2	—	1.9	—
Running Current (Rated)	A		4.3	4.6	5.3	5.7
Power Consumption Rated (Min.-Max.)	W		780 (300~960)	995 (290~1,500)	1,160 (300~1,270)	1,245 (310~1,860)
Power Factor	%		78.9	94.0	95.2	95.0
COP	W/W		3.21	3.42	3.02	3.21
Piping Connections	Liquid	mm	φ 6.4		φ 6.4	
	Gas	mm	φ 9.5		φ 9.5	
	Drain	mm	φ 18.0		φ 18.0	
Heat Insulation	Both Liquid and Gas Pipes				Both Liquid and Gas Pipes	
Indoor Unit		FLXS25BAVMB		FLXS35BAVMB		
Front Panel Color		Almond White		Almond White		
Air Flow Rate	m³/min (cfm)	H	7.6 (268)	9.2 (325)	8.6 (304)	9.8 (346)
		M	6.8 (240)	8.3 (293)	7.6 (268)	8.9 (314)
		L	6.0 (212)	7.4 (261)	6.6 (233)	8.0 (282)
		SL	5.2 (184)	6.6 (233)	5.6 (198)	7.2 (254)
Fan	Type	Sirocco Fan		Sirocco Fan		
	Motor Output	W	34		34	
	Speed	Steps	5 Steps, Silent, Auto		5 Steps, Silent, Auto	
Air Direction Control	Right, Left, Horizontal, Downward				Right, Left, Horizontal, Downward	
Air Filter	Removable / Washable / Mildew Proof				Removable / Washable / Mildew Proof	
Running Current (Rated)	A	0.32	0.34	0.36	0.36	
Power Consumption (Rated)	W	70	74	78	78	
Power Factor	%	95.1	94.6	94.2	94.2	
Temperature Control	Microcomputer Control				Microcomputer Control	
Dimensions (HxWxD)	mm	490x1,050x200		490x1,050x200		
Packaged Dimensions (HxWxD)	mm	566x1,100x280		566x1,100x280		
Weight	kg	16		16		
Gross Weight	kg	22		22		
Operation Sound	H/M/L/SL	dBA	37/34/31/28	37/34/31/29	38/35/32/29	39/36/33/30
Sound Power	H	dBA	53	—	54	—
Outdoor Unit		RXS25D3VMB		RXS35D3VMB		
Casing Color		Ivory White		Ivory White		
Compressor	Type	Hermetically Sealed Swing Type				
	Model	1YC23NXD#A		1YC23NXD#A		
	Motor Output	W	600			
Refrigerant Oil	Model	FVC50K				
	Charge	L	0.375			
Refrigerant	Model	R-410A				
	Charge	kg	0.8			
Air Flow Rate	m³/min (cfm)	H	36.2(1,278)	32.6(1,151)	33.5(1,183)	30.2(1,066)
		L	25.7(907)	30.6(1,080)	23.4(826)	28.3(999)
Fan	Type	Propeller		Propeller		
	Motor Output	W	31		35	
Running Current (Rated)	A	3.98	4.26	4.94	5.34	
Power Consumption (Rated)	W	710	921	1,082	1,167	
Power Factor	%	77.6	94.0	95.2	95.0	
Starting Current	A	4.6		5.7		
Dimensions (HxWxD)	mm	550x765x285		550x765x285		
Packaged Dimensions (HxWxD)	mm	589x882x363		589x882x363		
Weight	kg	30		32		
Gross Weight	kg	35		38		
Operation Sound	H/L	dBA	46/43	47/44	47/44	48/45
Sound Power	H	dBA	61	62	62	63
Drawing No.			3D050866		3D050868	

- Note:**
- MAX. interunit piping length: 20m
 - MAX. interunit height difference: 15m
 - Amount of additional charge of refrigerant 20g/m for piping length exceeding 10m
 - The data are based on the conditions shown in the table below.

Cooling	Heating	Piping Length
Indoor ; 27°CDB/19°CWB Outdoor ; 35°CDB/24°CWB	Indoor ; 20°CDB Outdoor ; 7°CDB/6°CWB	7.5m

Conversion Formulae
kcal/h=kWx860 Btu/h=kWx3414 cfm=m³/minx35.3

Part 3

Printed Circuit Board

Connector Wiring Diagram

1. Printed Circuit Board Connector Wiring Diagram.....	12
1.1 Indoor Unit.....	12
1.2 Outdoor Unit.....	14

1. Printed Circuit Board Connector Wiring Diagram

1.1 Indoor Unit

Connectors

- | | |
|------------------|---|
| 1) S6 | Connector for swing motor |
| 2) S7 | Connector for fan motor |
| 3) S21 | Connector for centralized control (HA) |
| 4) S24 | Connector for display PCB |
| 5) S25, S27, S36 | Connector for control PCB |
| 6) S26 | Connector for signal receiver PCB |
| 7) S31 (RTH) | Connector for room temperature thermistor |
| 8) S32 | Connector for heat exchanger thermistor |
| 9) S37 | Connector for power supply PCB |



Note: Other designations

- | | |
|---------|--|
| 1) V1 | Varistor |
| 2) JA | Address setting jumper |
| JB | Fan speed setting when compressor is OFF on thermostat |
| JC | Power failure recovery function |
| | * Refer to page 161 for detail. |
| 3) SW1 | Operation switch |
| 4) SW2 | Select switch for ceiling / floor |
| 5) LED1 | LED for operation (green) |
| 6) LED2 | LED for timer (yellow) |
| 7) LED3 | LED for Home Leave operation (red) |
| 8) FU1 | Fuse (3.15A) |

PCB Detail

PCB (1) : Control PCB (indoor unit)

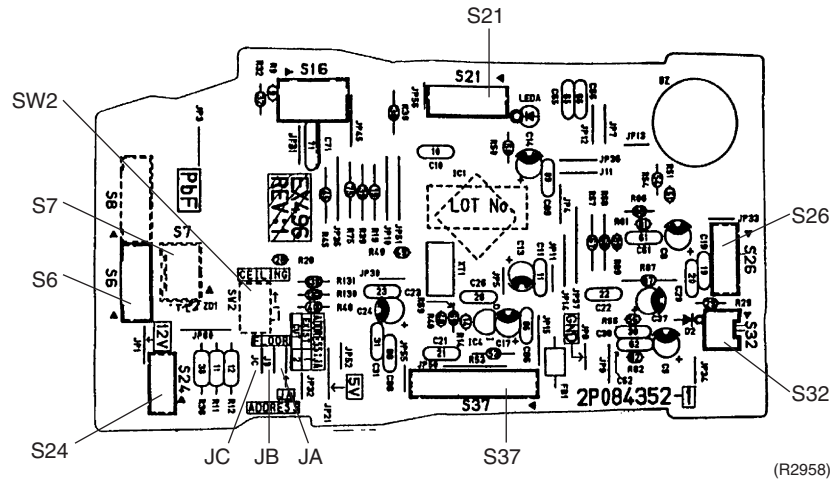

(R2958)

PCB (2) : Power Supply PCB (indoor unit)

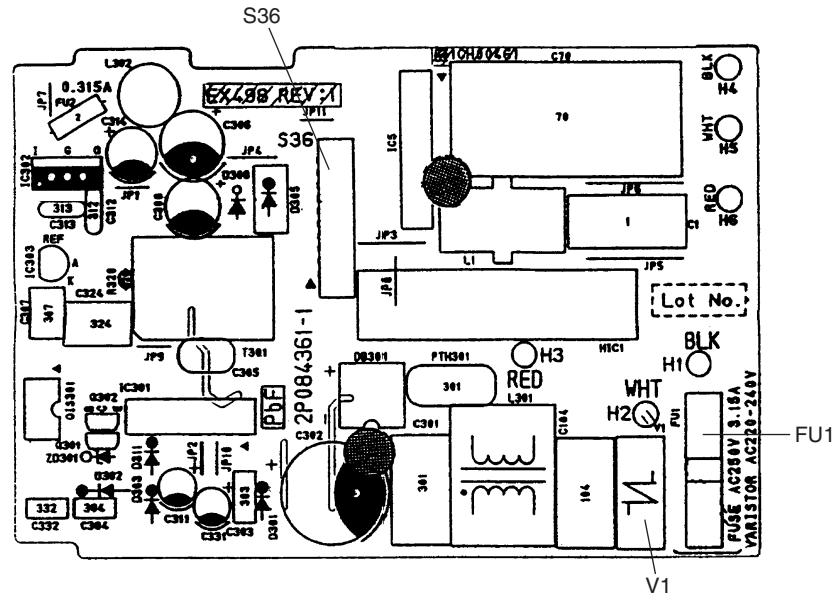

(R2959)

PCB (3) : Display PCB

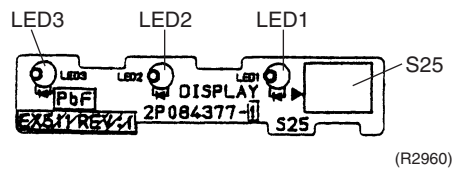

(R2960)

PCB (4) : Signal Receiver PCB

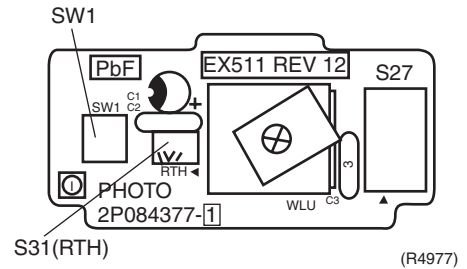

(R4977)

1.2 Outdoor Unit

Connectors

- | | |
|-----------------------|--|
| 1) S10 | Connector for filter PCB |
| 2) S11 | Connector for control PCB |
| 3) S20 | Connector for electronic expansion valve coil |
| 4) S30 | Connector for compressor motor |
| 5) S40 | Connector for overload protector |
| 6) S70 | Connector for fan motor |
| 7) S80 | Connector for four way valve coil |
| 8) S90 | Connector for thermistors
(outdoor air, heat exchanger, discharge pipe) |
| 9) HC3, HC4, HL3, HN3 | Connector for filter PCB |



Note: Other designations

- | | |
|---------------|--|
| 1) FU1, FU2 | Fuse (3.15A) |
| 2) FU3 | Fuse (20A) |
| 3) LED A | Service monitor LED |
| 4) V1, V2, V3 | Varistor |
| 5) J8 | Facility setting jumper
*Refer to page 45 for detail. |

PCB Detail

PCB(1): Filter PCB

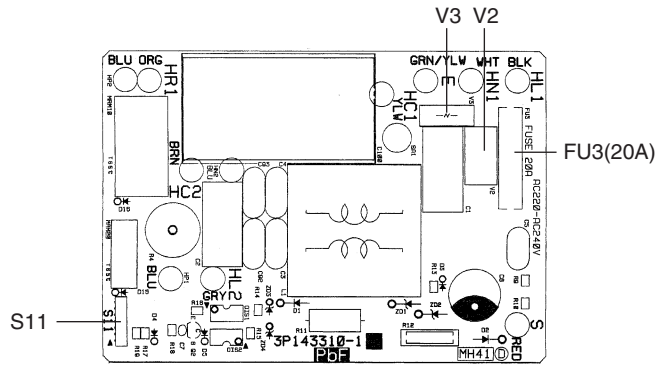

(R4293)

PCB(2): Control PCB (outdoor unit)

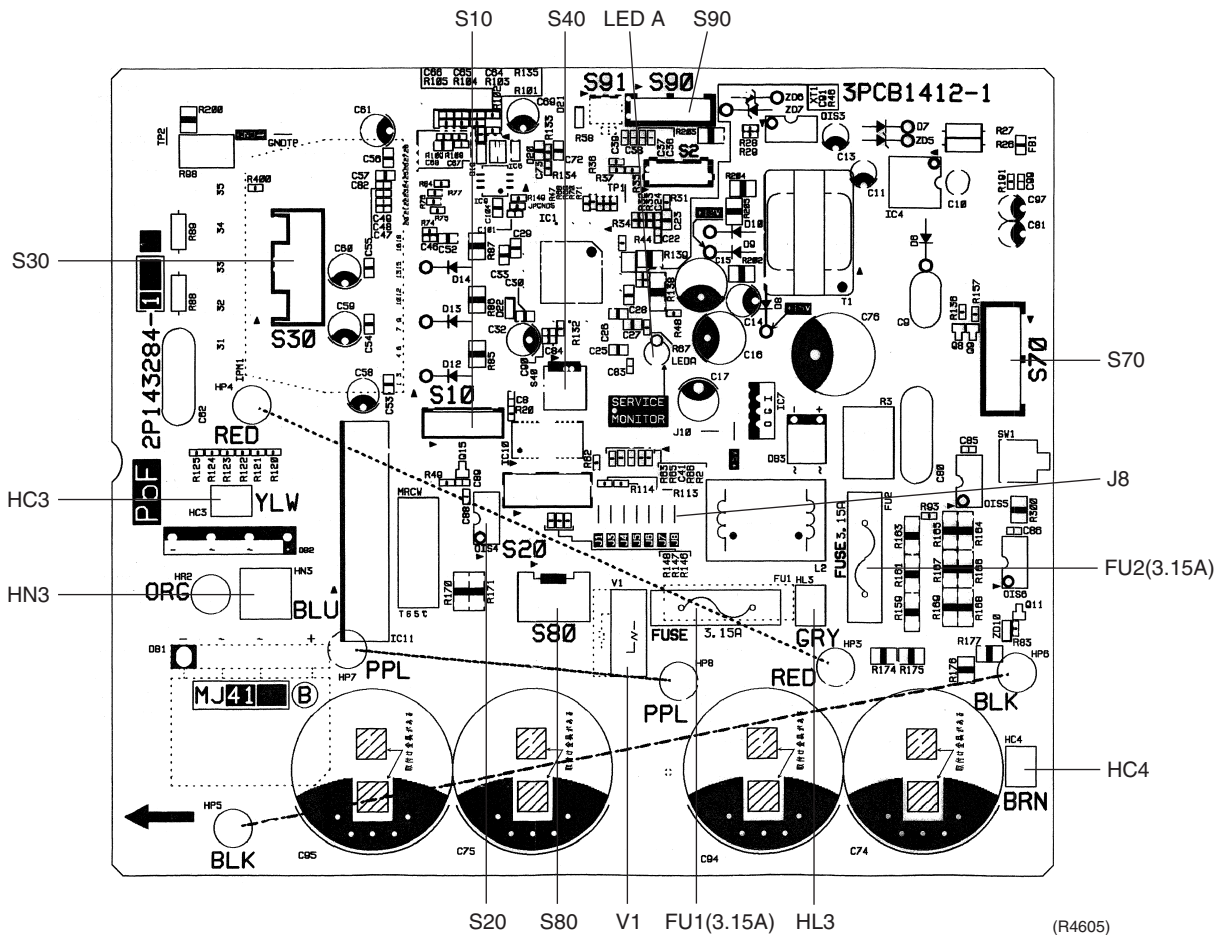

(R4605)

Part 4

Function and Control

1. Main Functions.....	18
1.1 Frequency Principle.....	18
1.2 Auto-Swing.....	20
1.3 Fan Speed Control for Indoor Units.....	21
1.4 Programme Dry Function.....	22
1.5 Automatic Operation.....	23
1.6 Thermostat Control.....	24
1.7 NIGHT SET Mode.....	25
1.8 HOME LEAVE Operation.....	26
1.9 Inverter POWERFUL Operation.....	27
1.10 Other Functions.....	28
2. Function of Thermistor.....	29
2.1 Heat Pump Model.....	29
2.2 Cooling Only Model.....	30
3. Control Specification.....	31
3.1 Mode Hierarchy.....	31
3.2 Frequency Control.....	32
3.3 Controls at Mode Changing / Start-up.....	34
3.4 Discharge Pipe Control.....	35
3.5 Input Current Control.....	36
3.6 Freeze-up Protection Control.....	37
3.7 Heating Peak-cut Control.....	37
3.8 Fan Control.....	38
3.9 Liquid Compression Protection Function 2.....	38
3.10 Defrost Control.....	39
3.11 Electronic Expansion Valve Control.....	40
3.12 Malfunctions.....	43
3.13 Forced Operation Mode.....	44
3.14 Additional Function.....	44
3.15 Facility Setting Jumper (cooling at low outdoor temperature).....	45

1. Main Functions

i Note: See the list of functions for the functions applicable to different models.

1.1 Frequency Principle

Main Control Parameters

The compressor is frequency-controlled during normal operation. The target frequency is set by the following 2 parameters coming from the operating indoor unit:

- The load condition of the operating indoor unit
- The difference between the room temperature and the set temperature

Additional Control Parameters

The target frequency is adapted by additional parameters in the following cases:

- Frequency restrictions
- Initial settings
- Forced cooling operation

Inverter Principle

To regulate the capacity, a frequency control is needed. The inverter makes it possible to vary the rotation speed of the compressor. The following table explains the conversion principle:

Phase	Description
1	The supplied AC power source is converted into the DC power source for the present.
2	The DC power source is reconverted into the three phase AC power source with variable frequency. <ul style="list-style-type: none"> ■ When the frequency increases, the rotation speed of the compressor increases resulting in an increased refrigerant circulation. This leads to a higher amount of the heat exchange per unit. ■ When the frequency decreases, the rotation speed of the compressor decreases resulting in a decreased refrigerant circulation. This leads to a lower amount of the heat exchange per unit.

Drawing of Inverter

The following drawing shows a schematic view of the inverter principle:

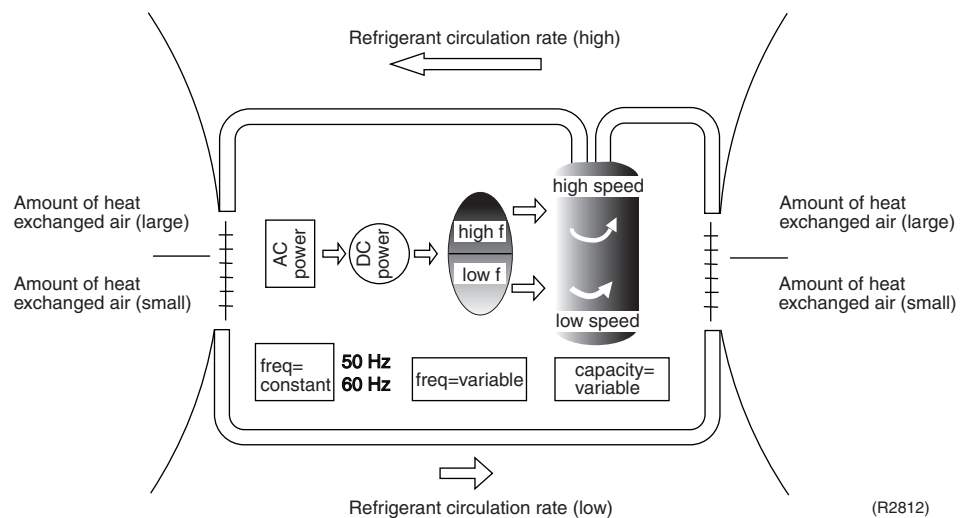

Inverter Features

The inverter provides the following features:

- The regulating capacity can be changed according to the changes in the outdoor air temperature and cooling / heating load.
- Quick heating and quick cooling
The compressor rotational speed is increased when starting the heating (or cooling). This enables a quick set temperature.

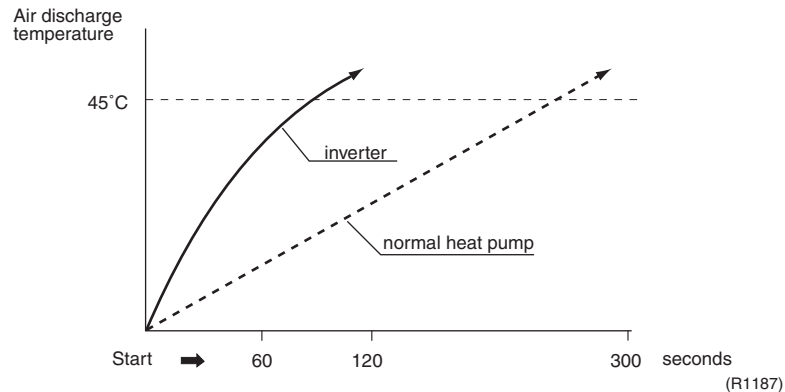

- Even during extreme cold weather, the high capacity is achieved. It is maintained even when the outdoor air temperature is 2°C.
- Comfortable air conditioning
A detailed adjustment is integrated to ensure a fixed room temperature. It is possible to air condition with a small room temperature variation.
- Energy saving heating and cooling
Once the set temperature is reached, the energy saving operation enables to maintain the room temperature at low power.

Frequency Limits

The following table shows the functions that define the minimum and maximum frequency:

Frequency limits	Limited during the activation of following functions
Low	<ul style="list-style-type: none"> ■ Four way valve operation compensation. Refer to page 34.
High	<ul style="list-style-type: none"> ■ Input current control. Refer to page 36. ■ Compressor protection function. Refer to page 35. ■ Heating peak-cut control. Refer to page 37. ■ Freeze-up protection control. Refer to page 37. ■ Defrost control. Refer to page 39.





Forced Cooling Operation

For more information, refer to "Forced operation mode" on page 44.

1.2 Auto-Swing

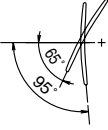
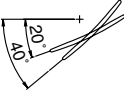
Auto-Swing

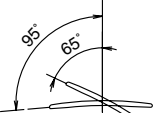
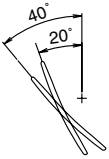
The following table explains the auto-swing process for heating, cooling, dry and fan:

	up and down (automatic)		right and left (manual)
	heating	cooling / dry / fan	
ceiling	 (R2963)	 (R2964)	 (R2965)
floor	 (R2966)	 (R2967)	 (R2968)

1.3 Fan Speed Control for Indoor Units

Control Mode

The airflow rate can be automatically controlled depending on the difference between the set temperature and the room temperature. This is done through phase control and Hall IC control.



For more information about Hall IC, refer to trouble shooting for fan motor on page 85.

Phase Steps

Phase control and fan speed control contains 9 steps: LLL, LL, SL, L, ML, M, MH, H and HH.

Step	Cooling	Heating	Dry mode
LLL	 (R4085)	 (R4085)	25 · 35kW class : 500 - 860 rpm (During powerful operation : 850 - 910 rpm)
LL			
SL (Silent)			
L			
ML			
M			
MH			
H			
HH (Powerful)			

= Within this range the airflow rate is automatically controlled when the FAN setting button is set to automatic.



Note:

1. During powerful operation, fan rotates at H tap + 50 rpm.
2. Fan stops during defrost operation.
3. In time of thermostat OFF, the fan rotates at the following speed.
 Cooling: The fan keeps rotating at the set tap.
 Heating: The fan keeps rotating at LLL tap.

Automatic Air Flow Control for Heating

The following drawing explains the principle for fan speed control for heating:

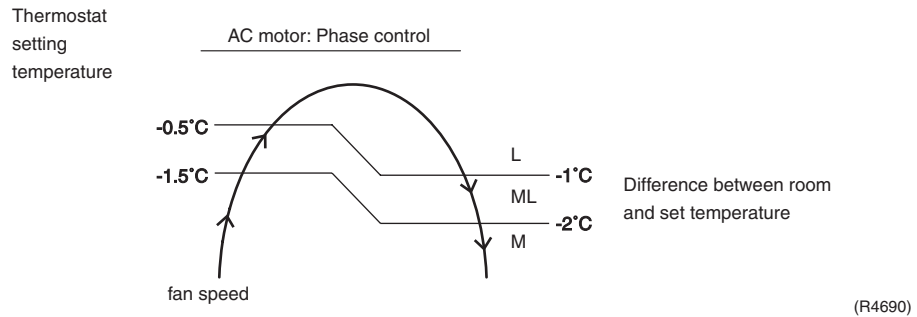

Automatic Air Flow Control for Cooling

The following drawing explains the principle of fan speed control for cooling:

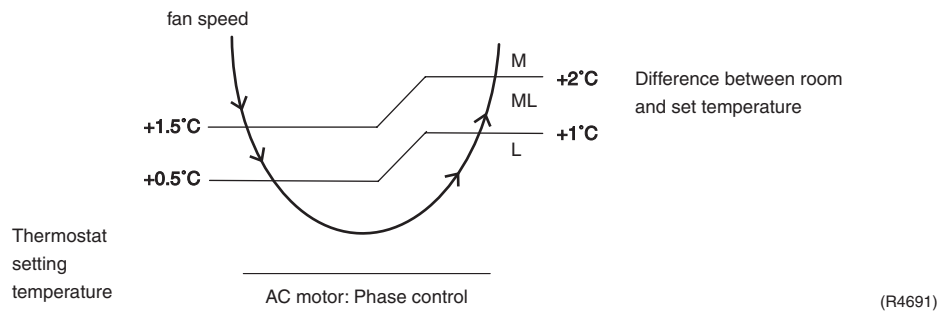

1.4 Programme Dry Function

Programme dry function removes humidity while preventing the room temperature from lowering.

Since the microcomputer controls both the temperature and air flow volume, the temperature adjustment and fan adjustment buttons are inoperable in this mode.

In Case of Inverter Units

The microcomputer automatically sets the temperature and fan settings. The difference between the room temperature at startup and the temperature set by the microcomputer is divided into two zones. Then, the unit operates in the dry mode with an appropriate capacity for each zone to maintain the temperature and humidity at a comfortable level.

Room temperature at startup	Temperature (ON point) at which operation starts	Frequency switching point	Temperature difference for operation stop
24°C	Room temperature at startup	0.5°C	1.5°C
18°C	18°C		1.0°C
17°C		—	

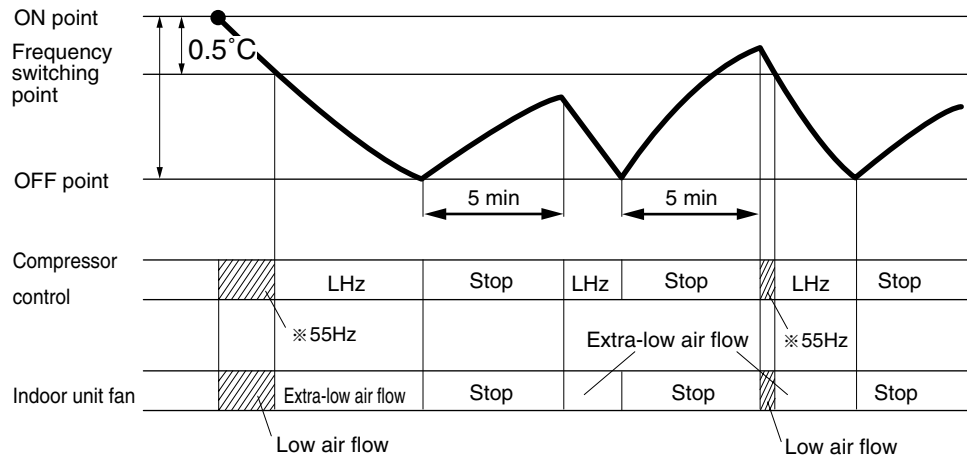

LHz indicates low frequency. Item marked with * varies depending on models.

(R1359)

1.5 Automatic Operation

Automatic Cooling / Heating Function (Heat Pump Only)

When the AUTO mode is selected with the remote controller, the microcomputer automatically determines the operation mode from cooling and heating according to the room temperature and setting temperature at the time of the operation startup, and automatically operates in that mode.

The unit automatically switches the operation mode to cooling or heating to maintain the room temperature at the main unit setting temperature.

Detailed Explanation of the Function

1. Remote controller setting temperature is set as automatic cooling / heating setting temperature (18 to 30°C).
2. Main unit setting temperature equals remote controller setting temperature plus correction value (correction value / cooling: 0 deg, heating: 2 deg.).
3. Operation ON / OFF point and mode switching point are as follows.
 - ① Heating → Cooling switching point:
Room temperature \geq Main unit setting temperature +2.5 deg.
 - ② Cooling → Heating switching point:
Room temperature $<$ Main unit setting temperature -2.5 deg.
 - ③ Thermostat ON / OFF point is the same as the ON / OFF point of cooling or heating operation.
4. During initial operation
 Room temperature \geq Remote controller setting temperature: Cooling operation
 Room temperature $<$ Remote controller setting temperature: Heating operation

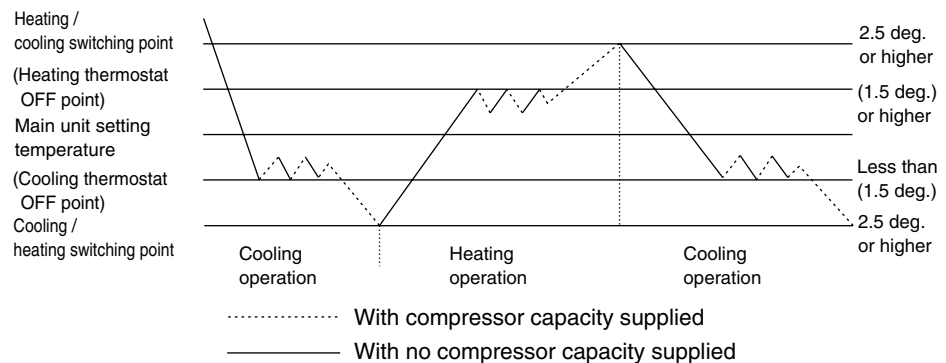

(R1360)

1.6 Thermostat Control

Thermostat control is based on the difference between the room temperature and the setpoint.

Thermostat OFF Condition

- ♦ The temperature difference is in the zone A.

Thermostat ON Condition

- ♦ The temperature difference is above the zone C after being in the zone A.
- ♦ The system resumes from defrost control in any zones except A.
- ♦ The operation turns on in any zones except A.
- ♦ The monitoring time has passed while the temperature difference is in the zone B.
(Cooling / Dry : 10 minutes, Heating : 10 seconds)

Cooling / Dry

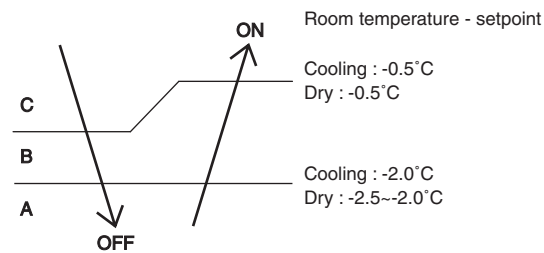

(R4668)

Heating

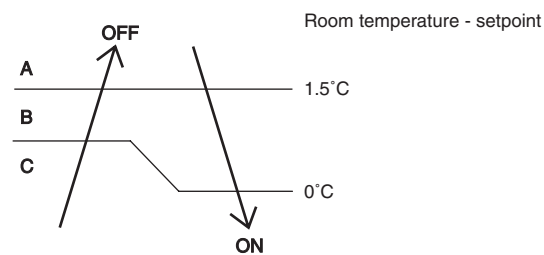

(R4669)

1.7 NIGHT SET Mode

When the OFF timer is set, the Night Set circuit automatically activates. The Night Set circuit maintains the airflow setting made by users.

The Night Set Circuit

The Night Set circuit continues heating or cooling the room at the set temperature for the first one hour, then automatically raises the temperature setting slightly in the case of cooling, or lowers it slightly in the case of heating, for economical operations. This prevents excessive heating in winter and excessive cooling in summer to ensure comfortable sleeping conditions, and also conserves electricity.

Cooling Operation

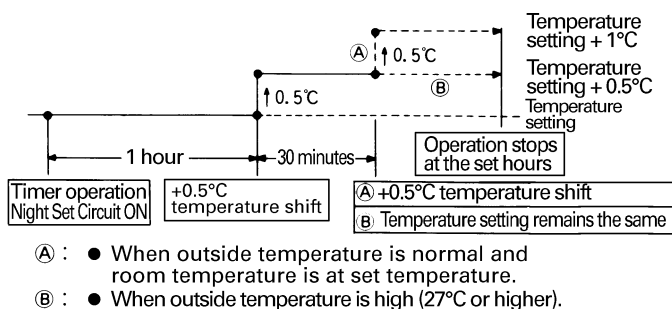

Heating Operation

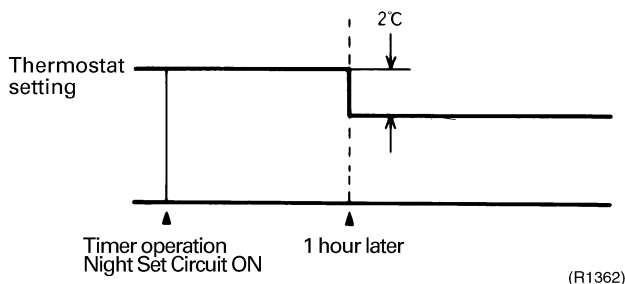

1.8 HOME LEAVE Operation

Outline

In order to respond to the customer's need for immediate heating and cooling of the room after returning home or for house care, a measure to switch the temperature and air volume from that for normal time over to outing time by one touch is provided. (This function responds also to the need for keeping up with weak cooling or heating.)

This time, we seek for simplicity of operation by providing the special temperature and air volume control for outing to be set by the exclusive button.

Detail of the Control

1. Start of Function

The function starts when the [HOME LEAVE] button is pressed in cooling mode or heating mode (including stopping and powerful operation). If this button is pressed while the operation is stopped, the function becomes effective when the operation is started. If this button is pressed in powerful operation, the powerful operation is reset and this function becomes effective.

- The [HOME LEAVE] button is ineffective in dry mode and fan mode.

2. Details of Function

A mark representing [HOME LEAVE] is indicated on the liquid crystal display of the remote controller. The indoor unit is operated according to the set temperature and air volume for HOME LEAVE which were pre-set in the memory of the remote controller.

The LED (Red) of indoor unit representing [HOME LEAVE] lights up. (It goes out when the operation is stopped.)

3. End of Function

The function ends when the [HOME LEAVE] button is pressed again during [HOME LEAVE] operation or when the powerful operation button is pressed.

Scene <cooling>



Scene <Heating>

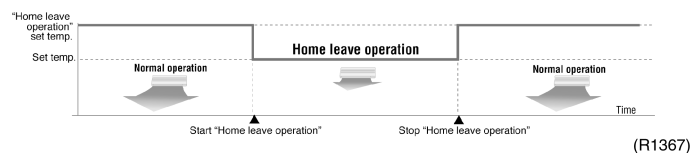
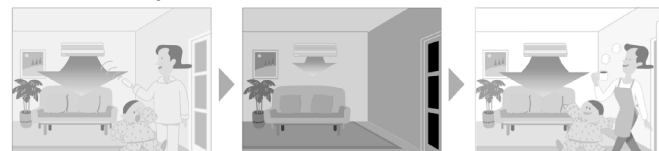

Others

The set temperature and set air volume are memorized in the remote controller. When the remote controller is reset due to replacement of battery, it is necessary to set the temperature and air volume again for [HOME LEAVE].

1.9 Inverter POWERFUL Operation

Outline

In order to exploit the cooling and heating capacity to full extent, operate the air conditioner by increasing the indoor fan rotating speed and the compressor frequency.

Details of the Control

When POWERFUL button is pushed in each operation mode, the fan speed / setting temperature will be converted to the following states in a period of twenty minutes.

Operation mode	Fan speed	Target set temperature
COOL	H tap + 50 rpm	18°C
DRY	Dry rotating speed + 50 rpm	Normally targeted temperature in dry operation; Approx. -2.5°C
HEAT	H tap + 50 rpm	30°C
FAN	H tap + 50 rpm	—
AUTO	Same as cooling / heating in Powerful operation	The target is kept unchanged

Ex.) : Powerful operation in cooling mode.

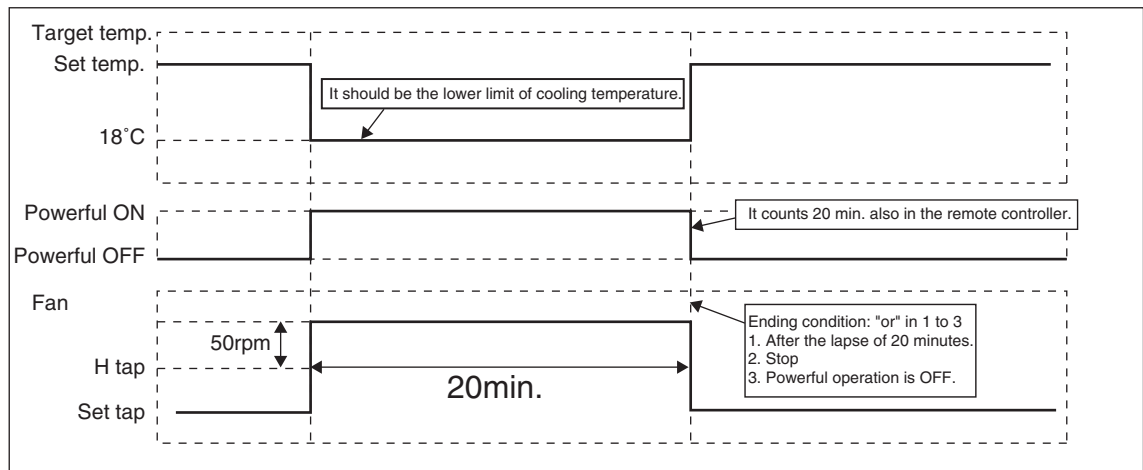

(R4674)

1.10 Other Functions

1.10.1 Hot Start Function

Heat Pump Only

In order to prevent the cold air blast that normally comes when heating is started, the temperature of the heat exchanger of the indoor unit is detected, and either the air flow is stopped or is made very weak thereby carrying out comfortable heating of the room.

*The cold air blast is also prevented using a similar control when the defrosting operation is started or when the thermostat gets turned ON.

1.10.2 Signal Receiving Sign

When the indoor unit receives a signal from the remote controller, the unit emits a signal receiving sound.

1.10.3 ON/OFF Button on Indoor Unit

An ON/OFF switch is provided on the front panel of the unit. Use this switch when the remote controller is missing or if its battery has run out.

Every press of the switch changes from Operation to Stop or from Stop to Operation

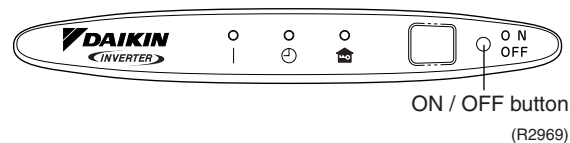

- Push this button once to start operation. Push once again to stop it.
- This button is useful when the remote controller is missing.
- The operation mode refers to the following table.

	Mode	Temperature setting	Air flow rate
Cooling Only	COOL	22°C	AUTO
Heat Pump	AUTO	25°C	AUTO

- In the case of multi system operation, there are times when the unit does not activate with this button.

1.10.4 Photocatalytic Deodorizing Filter

Photocatalytic Deodorizing Filter demonstrates powerful oxidation characteristics when subjected to harmless ultraviolet light. Photocatalytic deodorizing power is recovered simply by exposing the filter to the sun for 6 hours once every 6 months.

1.10.5 Air Purifying Filter

A double structure made up of a bacteriostatic filter and an Air-Purifying Filter traps dust, mildew, mites, tobacco smoke, and allergy-causing pollen. Replace the Air-Purifying Filter once every 3 months.

1.10.6 Mold Proof Air Filter

The filter net is treated with mold resisting agent TBZ (harmless, colorless, and odorless). Due to this treatment, the amount of mold growth is much smaller than that of normal filters.

1.10.7 Self-Diagnosis Digital Display

The microcomputer continuously monitors main operating conditions of the indoor unit, outdoor unit and the entire system. When an abnormality occur, the LCD remote controller displays error code. These indications allow prompt maintenance operations.

1.10.8 Auto-restart Function

Even if a power failure (including one for just a moment) occurs during the operation, the operation restarts in the condition before power failure automatically when power is restored. (Note) It takes 3 minutes to restart the operation because the 3-minute standby function is activated.

2. Function of Thermistor

2.1 Heat Pump Model

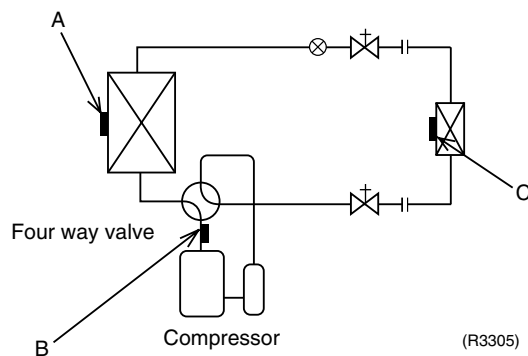

A Outdoor Heat Exchanger Thermistor (DCB)

1. The outdoor heat exchanger thermistor is used for controlling target discharge temperature. The system sets a target discharge temperature according to the outdoor and indoor heat exchanger temperature, and controls the electronic expansion valve opening so that the target discharge temperature can be obtained.
2. The outdoor heat exchanger thermistor is used for detecting disconnection of the discharge thermistor when cooling. When the discharge pipe temperature becomes lower than the outdoor heat exchanger temperature, the discharge pipe thermistor is judged as disconnected.
3. The outdoor heat exchanger thermistor is used for high pressure protection during cooling operation.

B Discharge Pipe Thermistor (DOT)

1. The discharge pipe thermistor is used for controlling temperature of the discharge pipe. If the temperature of discharge pipe (used in place of the inner temperature of the compressor) rises abnormally, the operating frequency drops or the operation halts.
2. The discharge pipe thermistor is used for detecting disconnection of the discharge thermistor.

C Indoor Heat Exchanger Thermistor (DCN)

1. The indoor heat exchanger thermistor is used for controlling target discharge temperature. The system sets a target discharge temperature according to the outdoor and indoor heat exchanger temperature, and controls the electronic expansion valve opening so that the target discharge temperature can be obtained.
2. The indoor heat exchanger thermistor is used for preventing freezing. During the cooling operation, if the temperature drops abnormally, the operating frequency becomes lower, then the operation halts.
3. The indoor heat exchanger thermistor is used for anti-icing control. During the cooling operation, if the heat exchanger temperature in the room where operation is halted becomes -1°C , it is assumed as icing.
4. During heating, the indoor heat exchanger thermistor is used for detecting disconnection of the discharge pipe thermistor. When the discharge pipe temperature becomes lower than the indoor heat exchanger temperature, the discharge pipe thermistor is judged as disconnected.

2.2 Cooling Only Model

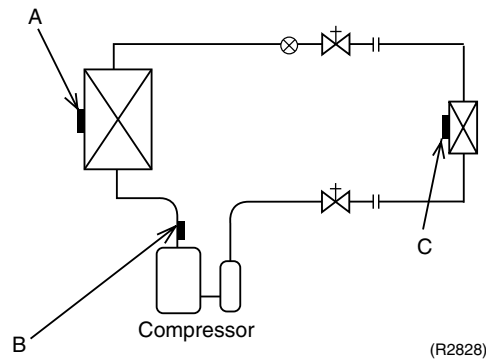

A Outdoor Heat Exchanger Thermistor (DCB)

1. The outdoor heat exchanger thermistor is used for controlling target discharge temperature. The system sets a target discharge temperature according to the outdoor and indoor heat exchanger temperature, and controls the electronic expansion valve opening so that the target discharge temperature can be obtained.
2. The outdoor heat exchanger thermistor is used for detecting disconnection of the discharge thermistor when cooling. When the discharge pipe temperature becomes lower than the outdoor heat exchanger temperature, the discharge pipe thermistor is judged as disconnected.
3. The outdoor heat exchanger thermistor is used for high pressure protection during cooling operation.

B Discharge Pipe Thermistor (DOT)

1. The discharge pipe thermistor is used for controlling temperature of the discharge pipe. If the temperature of discharge pipe (used in place of the inner temperature of the compressor) rises abnormally, the operating frequency drops or the operation halts.
2. The discharge pipe thermistor is used for detecting disconnection of the discharge thermistor.

C Indoor Heat Exchanger Thermistor (DCN)

1. The indoor heat exchanger thermistor is used for controlling target discharge temperature. The system sets a target discharge temperature according to the outdoor and indoor heat exchanger temperature, and controls the electronic expansion valve opening so that the target discharge temperature can be obtained.
2. The indoor heat exchanger thermistor is used for preventing freezing. During the cooling operation, if the temperature drops abnormally, the operating frequency becomes lower, then the operation halts.
3. The indoor heat exchanger thermistor is used for anti-icing control. During the cooling operation, if the heat exchanger temperature in the room where operation is halted becomes -1°C , it is assumed as icing.

3. Control Specification

3.1 Mode Hierarchy

Outline

There are two modes; the mode selected in user's place (normal air conditioning mode) and forced operation mode for installation and providing service.

Detail

1. For heat pump model

There are following modes; stop, cooling (includes drying), heating (include defrosting)

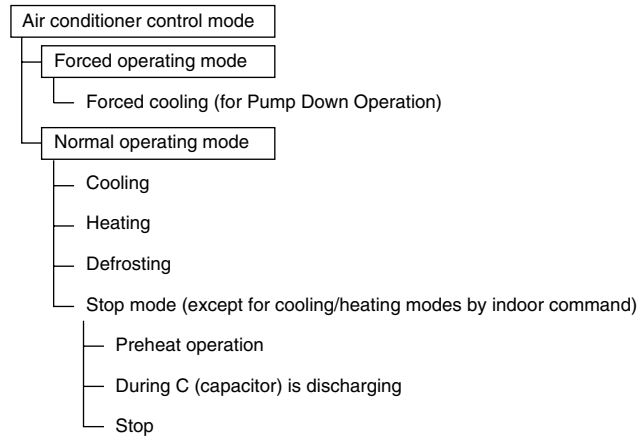

(R2829)

2. For cooling only model

There are following models; stop and cooling (including drying).

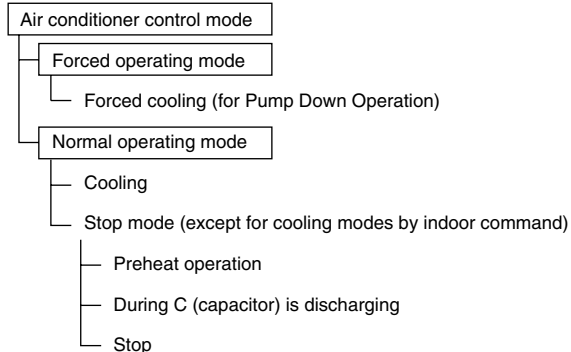

(R2830)



Note: Unless specified otherwise, an indoor dry operation command must be regarded as cooling operation.

3.2 Frequency Control

Outline

Frequency will be determined according to the difference between room and set temperature. The function is explained as follows.

1. How to determine frequency.
2. Frequency command from an indoor unit. (The difference between a room temperature and the temperature set by the remote controller.)
3. Frequency command from an indoor unit.
4. Frequency initial setting.
5. PI control.

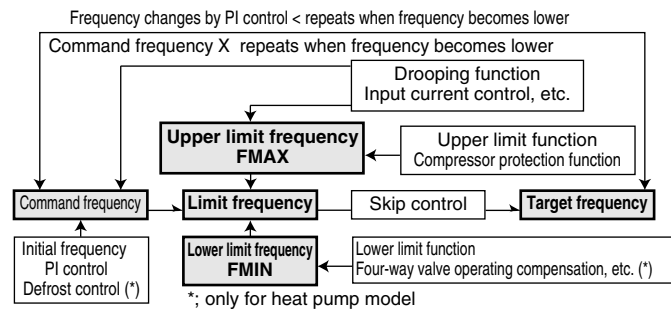

(R2831)

Detail

How to Determine Frequency

The compressor's frequency will finally be determined by taking the following steps.

For Heat Pump Model

1. Determine command frequency

- ◆ Command frequency will be determined in the following order of priority.
 - 1.1 Limiting frequency by drooping function
 - ◆ Input current, discharge pipes, peak cutting, freeze-up protection, dew prevention, fin thermistor temperature.
 - 1.2 Limiting defrost control time
 - 1.3 Forced cooling
 - 1.4 Indoor frequency command

2. Determine upper limit frequency

- ◆ Set a minimum value as an upper limit frequency among the frequency upper limits of the following functions:
Compressor protection, input current, discharge pipes, peak cutting, freeze-up protection, defrost.

3. Determine lower limit frequency

- ◆ Set a maximum value as a lower limit frequency among the frequency lower limits of the following functions:
Four way valve operating compensation, draft prevention, pressure difference upkeep.

4. Determine prohibited frequency

- ◆ There is a certain prohibited frequency such as a power supply frequency.

For Cooling Only Model

1. Determine command frequency

- ◆ Command frequency will be determined in the following order of priority.
 - 1.1 Limiting frequency by drooping function
Input current, discharge pipes, freeze-up protection, dew prevention, fin thermistor temperature.
 - 1.2 Indoor frequency command

2. Determine upper limit frequency

- ◆ Set a minimum value as an upper limit frequency among the frequency upper limits of the following functions:
Compressor protection, input current, discharge pipes, freeze-up protection, dew prevention, fin thermistor temperature.

3. Determine lower limit frequency

- ◆ Set a maximum value as an lower limit frequency among the frequency lower limits of the following functions:
Pressure difference upkeep.

4. Determine prohibited frequency

- ◆ There is a certain prohibited frequency such as a power supply frequency.

Indoor Frequency Command (ΔD signal)

The difference between a room temperature and the temperature set by the remote controller will be taken as the " ΔD signal" and is used for frequency command.

Temperature difference	ΔD signal	Temperature difference	ΔD signal	Temperature difference	ΔD signal	Temperature difference	ΔD signal
0	*Th OFF	2.0	4	4.0	8	6.0	C
0.5	1	2.5	5	4.5	9	6.5	D
1.0	2	3.0	6	5.0	A	7.0	E
1.5	3	3.5	7	5.5	B	7.5	F

*Th OFF = Thermostat OFF

Frequency Initial Setting**<Outline>**

When starting the compressor, or when conditions are varied due to the change of the room, the frequency must be initialized according to the ΔD value of the indoor unit and the Q value of the indoor unit.

Q value: Indoor unit output determined from indoor unit volume, air flow rate and other factors.

PI Control (Determine Frequency Up / Down by ΔD Signal)**1. P control**

Calculate ΔD value in each sampling time (20 seconds), and adjust the frequency according to its difference from the frequency previously calculated.

2. I control

If the operating frequency is not change more than a certain fixed time, adjust the frequency up and down according to the ΔD value, obtaining the fixed ΔD value.

When the ΔD value is small...lower the frequency.

When the ΔD value is large...increase the frequency.

3. Frequency management when other controls are functioning

- ◆ When frequency is drooping;
Frequency management is carried out only when the frequency droops.
- ◆ For limiting lower limit
Frequency management is carried out only when the frequency rises.

4. Upper and lower limit of frequency by PI control

The frequency upper and lower limits are set depending on indoor unit.

When low noise commands come from the indoor unit or when outdoor unit low noise or quiet commands come from indoor unit, the upper limit frequency must be lowered than the usual setting.

3.3 Controls at Mode Changing / Start-up

3.3.1 Preheating Operation

Outline	Operate the inverter in the open phase operation with the conditions including the preheating command from the discharge pipe temperature.
----------------	--

Detail	<p>Preheating ON Condition</p> <ul style="list-style-type: none"> ◆ When the discharge pipe temperature is below 10°C, inverter in open phase operation starts. <p>OFF Condition</p> <ul style="list-style-type: none"> ◆ When the discharge pipe temperature is higher than 12°C, inverter in open phase operation stops.
---------------	--

3.3.2 Four Way Valve Switching

Outline of Heating Operation	<p>Heat Pump Only</p> <p>During the heating operation current must be conducted and during cooling and defrosting current must not be conducted. In order to eliminate the switching sound (as the four way valve coil switches from ON to OFF) when the heating is stopped, the delay switch of the four way valve must be carried out after the operation stopped.</p>
-------------------------------------	---

Detail	<p>The OFF delay of four way valve Energize the coil for 160 sec after unit operation is stopped.</p>
---------------	---

3.3.3 Four Way Valve Operation Compensation

Outline	<p>Heat Pump Only</p> <p>At the beginning of the operation as the four way valve is switched, acquire the differential pressure required for activating the four way valve by having output the operating frequency, which is more than a certain fixed frequency, for a certain fixed time.</p>
----------------	---

Detail	<p>Starting Conditions</p> <ol style="list-style-type: none"> 1. When starting compressor for heating. 2. When the operating mode changes to cooling from heating. 3. When starting compressor for rushing defrosting or resetting. 4. When starting compressor for the first time after the reset with the power is ON. 5. When starting compressor for heating next to the suspension of defrosting. 6. When starting compressor next to the fault of switching over cooling / heating. <p>Set the lower limit frequency (cooling : 68Hz, heating : 66Hz) for 45 seconds with any conditions 1 through 4 above.</p>
---------------	--

3.3.4 3-minute Standby

Prohibit to turn ON the compressor for 3 minutes after turning it off.
(Except when defrosting. (Only for Heat Pump Model).)

3.3.5 Compressor Protection Function

When turning the compressor from OFF to ON, the upper limit of frequency must be set as follows. (The function must not be used when defrosting (only for heat pump model).)

FCG 3	88
FCG 2	64
FCG 1	48
TCG 1	240
TCG 2	360
TCG 3	180

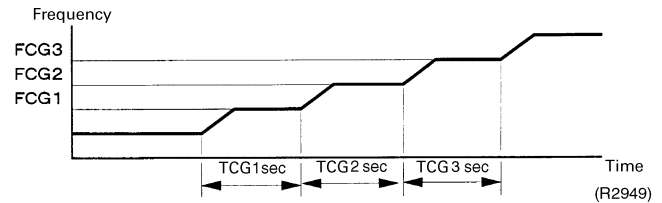

3.4 Discharge Pipe Control

Outline

The discharge pipe temperature is used as the compressor's internal temperature. If the discharge pipe temperature rises above a certain level, the operating frequency upper limit is set to keep this temperature from going up further.

Detail

Divide the Zone

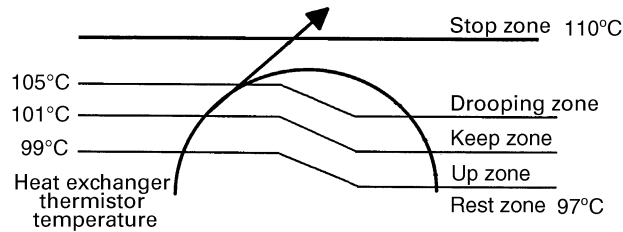

(R4270)

Management within the Zones

Zone	Control contents
Stop zone	When the temperature reaches the stop zone, stop the compressor and correct abnormality.
Drooping zone	Start the timer, and the frequency will be drooping.
Keep zone	Keep the upper limit of frequency.
Return / Reset zone	Cancel the upper limit of frequency.

3.5 Input Current Control

Outline

The microcomputer calculates the input current during the compressor is running, and set the frequency upper limit from such input current.

In case of heat pump model, this control is the upper limit control function of the frequency which takes priority of the lower limit of four way valve activating compensation.

Detail

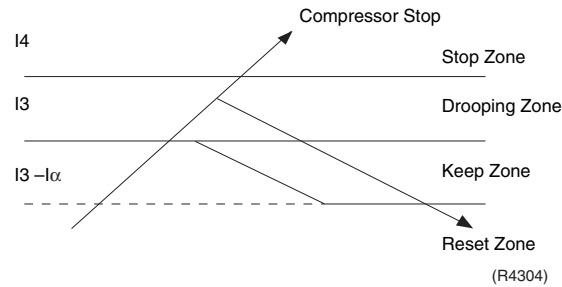

Frequency control in each zone

Drooping zone

- ♦ The maximum limit of the compressor frequency in this control is defined as operation frequency – 2Hz.
- ♦ After this, the output frequency is pulled down by 2Hz every second until it reaches the steady zone.

Keep zone

- ♦ The present maximum frequency goes on.

Reset zone

- ♦ Limit of the frequency is cancelled.

Stop zone

- ♦ After 2.5 s in this zone, the compressor is stopped.

	Cooling		Heating	
	25 class	35 class	25 class	35 class
I4 (A)	12		12	
I3 (A)	6.0	7.25	7.5	8.25
I3-1α (A)	5.25	6.5	6.75	7.5

Limitation of current drooping and stop value according to the outdoor air temperature

1. In case the operation mode is cooling
 - ♦ The current droops when outdoor air temperature becomes higher than a certain level (model by model).
2. In case the operation mode is heating (only for heat pump model)
 - ♦ The current droops when outdoor air temperature becomes higher than a certain level (model by model).

3.6 Freeze-up Protection Control

Outline

During cooling operation, the signals being sent from the indoor unit allow the operating frequency limitation and then prevent freezing of the indoor heat exchanger. (The signal from the indoor unit must be divided into the zones as the followings.)

Detail

Conditions for Start Controlling

Judge the controlling start with the indoor heat exchanger temperature after 2 sec from operation start.

Control in Each Zone

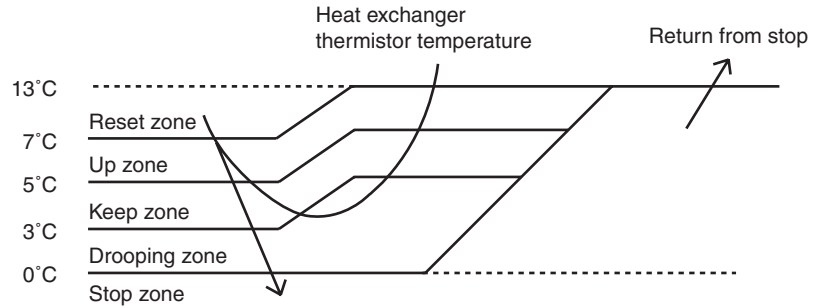

(R4561)

3.7 Heating Peak-cut Control

Outline

Heat Pump Only

During heating operation, the signals being sent from the indoor unit allow the operating frequency limitation and prevent abnormal high pressure. (The signal from the indoor unit must be divided as follows.)

Detail

Conditions for Start Controlling

Judge the controlling start with the indoor heat exchanger temperature after 2 sec. from operation start.

Control in Each Zone

The heat exchange intermediate temperature of indoor unit controls the following.

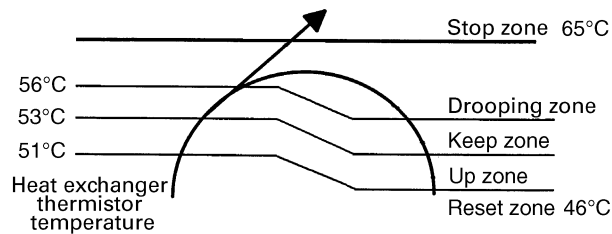

(R4589)

3.8 Fan Control

- Outline** Fan control is carried out with following functions.
1. Fan control when defrosting
 2. Fan OFF delay when stopped
 3. ON/OFF control when cooling operation
 4. Fan control when forced operation
 5. Fan control in low noise mode
 6. Fan control during heating operation
 7. Fan control in the quiet mode
 8. Fan control in the powerful mode
 9. Fan control for pressure difference upkeep
-

- Detail** **Fan OFF Control when Stopped**
- Fan OFF delay for 60 seconds must be made when the compressor is stopped.
-

3.9 Liquid Compression Protection Function 2

- Outline** In order to obtain the dependability of the compressor, the compressor must be stopped according to the conditions of the temperature of the outdoor air and outdoor heat exchanger.
-

- Detail**
- Operation stop depending on the outdoor air temperature
Compressor operation turns OFF under the conditions that the system is in cooling operation and outdoor air temperature is below -10°C .

3.10 Defrost Control

Outline

Heat Pump Only

Defrosting is carried out by the cooling cycle (reverse cycle). The defrosting time or outdoor heat exchanger temperature must be more than its fixed value when finishing.

Detail

Conditions for Starting Defrost

The starting conditions must be made with the outdoor air temperature and heat exchanger temperature. Under the conditions that the system is in heating operation, 6 minutes after the compressor is started and more than 28 minutes of accumulated time pass since the start of the operation or ending the defrosting.

Conditions for Canceling Defrost

The judgment must be made with heat exchanger temperature. (4°C-22°C)

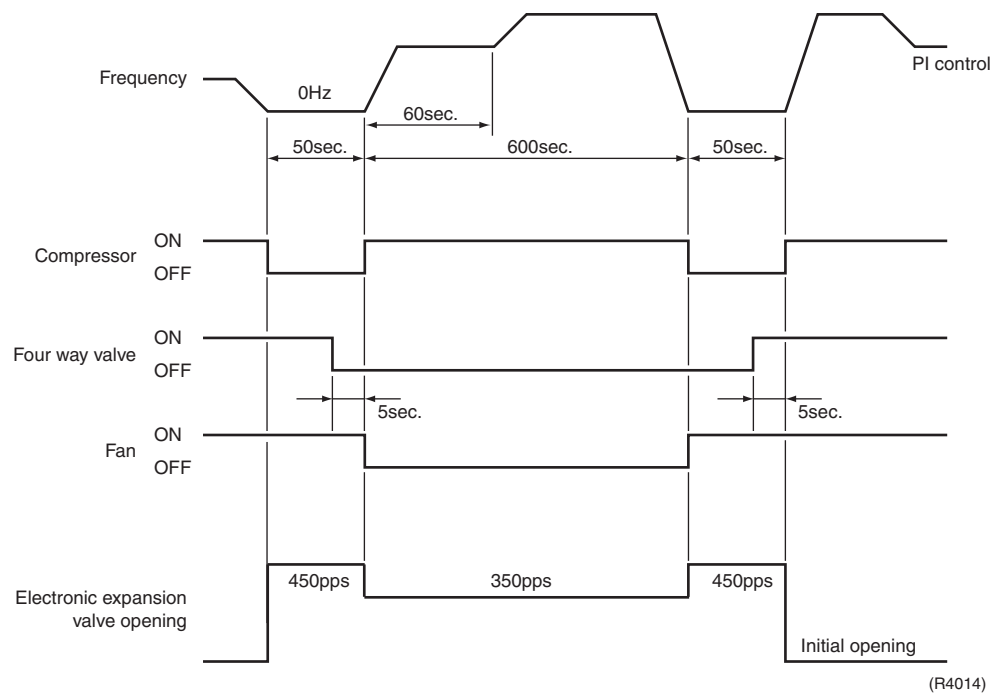

3.11 Electronic Expansion Valve Control

Outline

The following items are included in the electronic expansion valve control.

Electronic expansion valve is fully closed

1. Electronic expansion valve is fully closed when turning on the power.
2. Pressure equalizing control

Open Control

1. Electronic expansion valve control when starting operation
2. Control when frequency changed
3. Control for defrosting (only for heat pump model)
4. Control when a discharge pipe temperature is abnormally high
5. Control when the discharge pipe thermistor is disconnected

Feedback Control

1. Discharge pipe temperature control

Detail

The followings are the examples of control which function in each mode by the electronic expansion valve control.

Operation pattern		Control when frequency changed	Control for abnormally high discharge pipe temperature	
When power is turned ON	○ : function × : not function			
↓		Fully closed when power is turned ON	×	×
Cooling operation		Open control when starting	×	○
↓		(Control of target discharge pipe temperature)	○	○
Stop		Pressure equalizing control	×	×
Heating operation (only for heat pump model)		Open control when starting	×	○
↓		(Control of target discharge pipe temperature)	○	○
Stop		(Defrost control FD=1) (only for heat pump model)	×	×
Heating operation (only for heat pump model)		Pressure equalizing control	×	×
↓		Open control when starting	×	○
Control of discharge pipe thermistor disconnection		Continue	×	×
Stop		Pressure equalizing control	×	×

(R2833)

3.11.1 Fully Closing with Power ON

Initialize the electronic expansion valve when turning on the power, set the opening position and develop pressure equalizing.

3.11.2 Pressure Equalization Control

When the compressor is stopped, open and close the electronic expansion valve and develop pressure equalization.

3.11.3 Opening Limit

Outline

Limit a maximum and minimum opening of the electronic expansion valve.

Detail

- ◆ A maximum electronic expansion valve opening : 480 pulses
 - ◆ A minimum electronic expansion valve opening : 52 pulses
- The electronic expansion valve is fully closed in the room where cooling is stopped and is opened with fixed opening during defrosting.

3.11.4 Starting Operation Control

Control the electronic expansion valve opening when the system is starting, and prevent the system to be super heated or moistened.

3.11.5 High Temperature of the Discharge Pipe

When the compressor is operating, if the discharge pipe temperature exceeds a certain value, open the electronic expansion valve and remove the refrigerant to the low pressure side and lower discharge temperature.

3.11.6 Disconnection of the Discharge Pipe Thermistor

Outline

Detect a disconnected discharge pipe thermistor by comparing the discharge pipe temperature with the condensation temperature. If any is disconnected, open the electronic expansion valve according to the outdoor air temperature and the operating frequency and operate for a specified time, and then stop.

After 3 minutes of waiting, restart the unit and check if any is disconnected. If any is disconnected stop the system after operating for a specified time. If the disconnection is detected 4 times in succession, then the system will be down.

Detail

Detect Disconnection

If the timer for open control (cooling : 13min., heating : 15min.) becomes over, and the 9-minute timer for the compressor operation continuation is not counting time, the following adjustment must be made.

1. When the operation mode is cooling
When the discharge pipe temperature is lower than the outdoor heat exchanger temperature, the discharge pipe thermistor disconnection must be ascertained.
2. When the operation mode is heating (only for heat pump model)
When the discharge pipe temperature is lower than the max temperature of indoor unit heat exchanger, the discharge pipe thermistor disconnection must be ascertained.

Adjustment when the thermistor is disconnected

When compressor stop repeats specified time, the system should be down.

3.11.7 Control when frequency is changed

When the target discharge pipe temperature control is active, if the target frequency is changed for a specified value in a certain time period, cancel the target discharge pipe temperature control and change the target opening of the electronic expansion valve according to the shift.

3.11.8 Target Discharge Pipe Temperature Control

Obtain the target discharge pipe temperature from the indoor and outdoor heat exchanger temperature, and adjust the electronic expansion valve opening so that the actual discharge pipe temperature become close to that temperature. (Indirect SH control using the discharge pipe temperature)

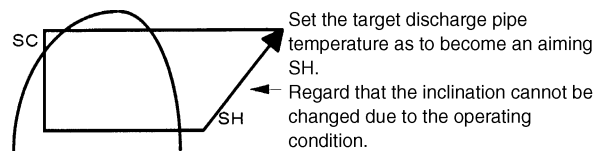

(R1389)

Determine a correction value of the electronic expansion valve compensation and drive it according to the deflection of the target discharge temperature and actual discharge temperature, and the discharge temperature variation by the 20 sec.

3.12 Malfunctions

3.12.1 Sensor Malfunction Detection

Sensor malfunction may occur in the thermistor.

Relating to Thermistor Malfunction

1. Outdoor heat exchanger thermistor
2. Discharge pipe thermistor
3. Fin thermistor
4. Outdoor air thermistor

3.12.2 Detection of Overload and Over Current

Outline

In order to protect the inverter, detect an excessive output current, and for protecting compressor, monitor the OL operation.

Detail

- If the OL (compressor head) temperature exceeds 120°C (depending on the model), the compressor gets interrupted.
- If the inverter current exceeds 22 A, the compressor gets interrupted too.

3.12.3 Insufficient Gas Control

Outline

There are three ways of control to detect insufficient gas.

I Detecting by power consumption

If the power consumption is below the specified value and the frequency is higher than the specified frequency, it is regarded as insufficient gas.

The power consumption is weak comparing with that in the normal operation when gas is insufficient, and gas insufficiency is detected by checking a power consumption.

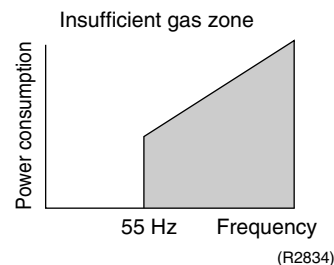

II Detecting by discharge pipe temperature

If the discharge temperature is higher than the target discharge pipe temperature, and the electronic expansion valve is fully open (480 pulses) more than the specified time, it is regarded as insufficient gas.

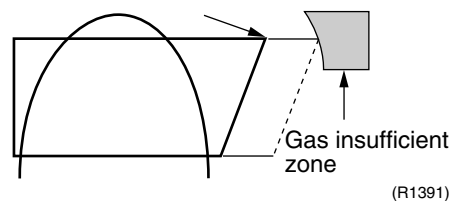

III Detecting by the difference of temperature

If the difference between inhale and exhale temperature is smaller than the specified value, it is regarded as insufficient gas.

Detail**I Judgment by power consumption**

When an output frequency is exceeds 55 Hz and the input current is less than specified value, the adjustment is made for insufficient gas.

II Judgment by discharge pipe temperature

When discharge pipe temperature is 30°C higher than target value and the electronic expansion valve opening is 480 pulses (max.), the adjustment is made for insufficient gas.

III Judgment by the difference of temperature

When the difference of the temperature is smaller than Δ , it is regarded as insufficient gas.

		Δ
Cooling	room temperature – indoor heat exchanger temperature	4.0°C
	outdoor heat exchanger temperature – outdoor temperature	4.0°C
Heating	indoor heat exchanger temperature – room temperature	3.0°C
	outdoor temperature – outdoor heat exchanger temperature	3.0°C

3.13 Forced Operation Mode

Outline

Forced operating mode includes only forced cooling.

Detail**Forced Cooling**

Item	Forced Cooling
Forced operation allowing conditions	1) The outdoor unit is not abnormal and not in the 3-minute stand-by mode. 2) The operating mode of the outdoor unit is the stop mode. 3) The forced operation is ON. The forced operation is allowed when the above "and" conditions are met.
Starting/adjustment	If the forced operation switch is pressed as the above conditions are met.
1) Command frequency	68 Hz
2) Electronic expansion valve opening	It depends on the capacity of the indoor unit.
3) Outdoor unit adjustment	Compressor is in operation.
4) Indoor unit adjustment	The command of forced operation is transmitted to the indoor unit.
End	1) When the forced operation switch is pressed again. 2) The operation is to end automatically after 15 min.
Others	The protect functions are prior to all others in the forced operation.

3.14 Additional Function

3.14.1 POWERFUL Operation Mode

Compressor operating frequency is increased to PI Max. (Max. Hz of operating room) and outdoor unit airflow rate is increased.

3.14.2 Voltage Detection Function

Power supply voltage is detected each time equipment operation starts.

3.15 Facility Setting Jumper (cooling at low outdoor temperature)

Outline

This function is limited only for facilities (the target of air conditioning is equipment (such as computer)). Never use it in a residence or office (the space where there is a human).

Detail

You can expand the operation range to -15°C by cutting jumper 8 (J8) on the PCB. If the outdoor temperature falls to -20°C or lower, the operation will stop. If the outdoor temperature rises, the operation will start again.

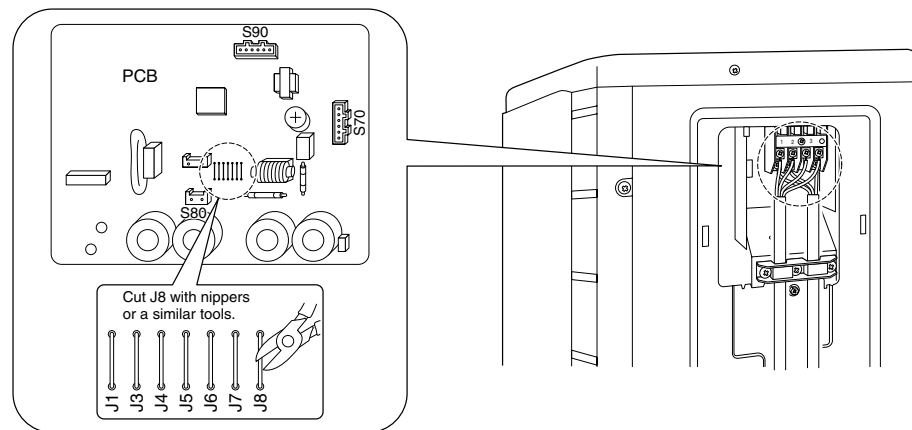

Caution

1. If the outdoor unit is installed where the heat exchanger of the unit is exposed to direct wind, provide a windbreak wall.
2. Intermittent noises may be produced by the indoor unit due to the outdoor fan turning on and off when using facility settings.
3. Do not place humidifiers or other items which might raise the humidity in rooms where facility settings are being used.
A humidifier might cause dew jumping from the indoor unit outlet vent.
4. Cutting jumper 8 (J8) sets the indoor fan tap to the highest position. Notify the user about this.

Part 5

System Configuration

1. System Configuration.....	48
2. Instruction.....	49
2.1 Safety precautions.....	49
2.2 Names of parts.....	51
2.3 Preparation before Operation.....	54
2.4 AUTO · DRY · COOL · HEAT · FAN Operation.....	57
2.5 Adjusting the Air Flow Direction.....	59
2.6 POWERFUL Operation.....	61
2.7 OUTDOOR UNIT SILENT Operation.....	62
2.8 HOME LEAVE Operation.....	63
2.9 TIMER Operation.....	65
2.10 Care and Cleaning.....	67
2.11 Troubleshooting.....	70

1. System Configuration

After the installation and test operation of the room air conditioner have been completed, it should be operated and handled as described below. Every user would like to know the correct method of operation of the room air conditioner, to check if it is capable of cooling (or heating) well, and to know a clever method of using it.



In order to meet this expectation of the users, giving sufficient explanations taking enough time can be said to reduce about 80% of the requests for servicing. However good the installation work is and however good the functions are, the customer may blame either the room air conditioner or its installation work because of improper handling. The installation work and handing over of the unit can only be considered to have been completed when its handling has been explained to the user without using technical terms but giving full knowledge of the equipment.





2. Instruction

2.1 Safety precautions

Safety precautions

- Keep this manual where the operator can easily find them.
- Read this manual attentively before starting up the unit.
- For safety reason the operator must read the following cautions carefully.
- This manual classifies precautions into WARNINGS and CAUTIONS. Be sure to follow all precautions below: they are all important for ensuring safety.

 WARNING If you do not follow these instructions exactly, the unit may cause property damage, personal injury or loss of life.	 CAUTION If you do not follow these instructions exactly, the unit may cause minor or moderate property damage or personal injury.
---	--



- | | |
|--|--|
| <ul style="list-style-type: none">  Never do.  Be sure to earth the air conditioner.  Never touch the air conditioner (including the remote controller) with a wet hand. | <ul style="list-style-type: none">  Be sure to follow the instructions.  Never cause the air conditioner (including the remote controller) to get wet. |
|--|--|

WARNING

- In order to avoid fire, explosion or injury, do not operate the unit when harmful, among which flammable or corrosive gases, are detected near the unit. 
- It is not good for health to expose your body to the air flow for a long time.
- Do not put a finger, a rod or other objects into the air outlet or inlet. As the fan is rotating at a high speed, it will cause injury.
- Do not attempt to repair, relocate, modify or reinstall the air conditioner by yourself. Incorrect work will cause electric shocks, fire etc.
For repairs and reinstallation, consult your Daikin dealer for advice and information.

- The refrigerant used in the air conditioner is safe. Although leaks should not occur, if for some reason any refrigerant happens to leak into the room, make sure it does not come in contact with any flame as of gas heaters, kerosene heaters or gas range. 
- If the air conditioner is not cooling (heating) properly, the refrigerant may be leaking, so call your dealer.
When carrying out repairs accompanying adding refrigerant, check the content of the repairs with our service staff.
- Do not attempt to install the air conditioner by your self. Incorrect work will result in water leakage, electric shocks or fire.
For installation, consult the dealer or a qualified technician.
- In order to avoid electric shock, fire or injury, if you detect any abnormally such as smell of fire, stop the operation and turn off the breaker. And call your dealer for instructions.

CAUTION

- The air conditioner must be earthed. Incomplete earthing may result in electric shocks. Do not connect the earth line to a gas pipe, water pipe, lightning rod, or a telephone earth line. 
- In order to avoid any quality deterioration, do not use the unit for cooling precision instruments, food, plants, animals or works of art. 
- Never expose little children, plants or animals directly to the air flow.
- Do not place appliances which produce open fire in places exposed to the air flow from the unit or under the indoor unit. It may cause incomplete combustion or deformation of the unit due to the heat.
- Do not block air inlets nor outlets. Impaired air flow may result in insufficient performance or trouble.

- Do not stand or sit on the outdoor unit. Do not place any object on the unit to avoid injury, do not remove the fan guard.
- Do not place anything under the indoor or outdoor unit that must be kept away from moisture. In certain conditions, moisture in the air may condense and drip.
- After a long use, check the unit stand and fittings for damage.
- Do not touch the air inlet and aluminum fins of outdoor unit. It may cause injury.
- The appliance is not intended for use by young children or infirm persons without supervision.
- Young children should be supervised to ensure that they do not play with the appliance.

-
- To avoid oxygen deficiency, ventilate the room sufficiently if equipment with burner is used together with the air conditioner. 
 - Before cleaning, be sure to stop the operation, turn the breaker off or pull out the supply cord.
 - Do not connect the air conditioner to a power supply different from the one as specified. It may cause trouble or fire.
 - Depending on the environment, an earth leakage breaker must be installed. Lack of an earth leakage breaker may result in electric shocks.
 - Arrange the drain hose to ensure smooth drainage. Incomplete draining may cause wetting of the building, furniture etc.
 - Do not place objects in direct proximity of the outdoor unit and do not let leaves and other debris accumulate around the unit.
Leaves are a hotbed for small animals which can enter the unit. Once in the unit, such animals can cause malfunctions, smoke or fire when making contact with electrical parts.

-
- Do not operate the air conditioner with wet hands. 

-
- Do not wash the indoor unit with excessive water, only use a slightly wet cloth. 
 - Do not place things such as vessels containing water or anything else on top of the unit. Water may penetrate into the unit and degrade electrical insulations, resulting in an electric shock.

Installation site

- To install the air conditioner in the following types of environments, consult the dealer.
 - Places with an oily ambient or where steam or soot occurs.
 - Salty environment such as coastal areas.
 - Places where sulfide gas occurs such as hot springs.
 - Places where snow may block the outdoor unit.

The drain from the outdoor unit must be discharged to a place of good drainage.

Consider nuisance to your neighbours from noises

- For installation, choose a place as described below.
 - A place solid enough to bear the weight of the unit which does not amplify the operation noise or vibration.
 - A place from where the air discharged from the outdoor unit or the operation noise will not annoy your neighbours.

Electrical work

- For power supply, be sure to use a separate power circuit dedicated to the air conditioner.

System relocation

- Relocating the air conditioner requires specialized knowledge and skills. Please consult the dealer if relocation is necessary for moving or remodeling.

2.2 Names of parts

Names of parts

Indoor Unit

The indoor unit can be installed either to the ceiling or to a wall. The descriptions contained in this manual show the case when installation is being carried out to the ceiling. (The methods of operation used are the same when installing to a wall.)

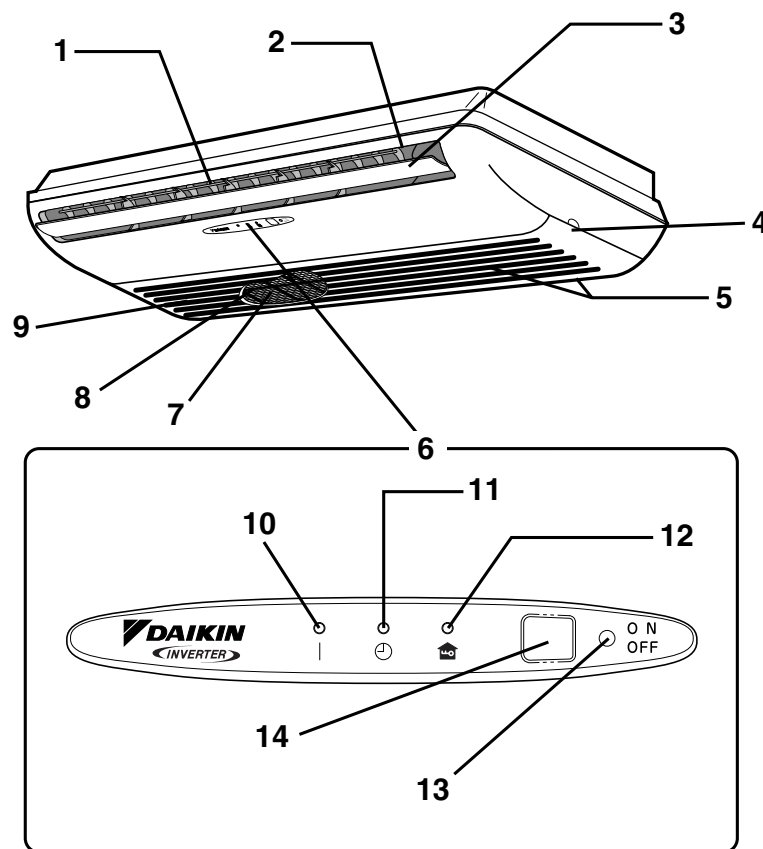

Opening the front grille

How to open the front grille : (page 22)

CAUTION

- Before opening the front grille, be sure to stop the operation and turn the breaker OFF.

■ Outdoor Unit

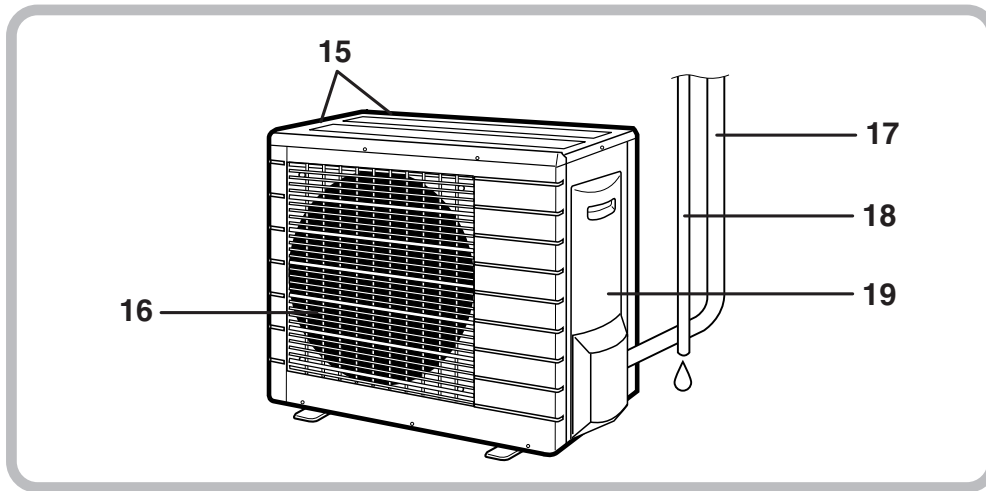

■ Indoor Unit

1. **Louvers (vertical blades):**
The louvers are inside of the air outlet. (page 12.)
2. **Air outlet**
3. **Flap (horizontal blade):** (page 12.)
4. **Grille tab**
5. **Air inlet**
6. **Display**
7. **Air filter**
8. **Photocatalytic deodorizing filter or Air purifying filter:**
 - These filters are attached to the inside of the air filters.
9. **Front grille**
10. **Operation lamp (green)**
11. **TIMER lamp (yellow):** (page 18.)
12. **HOME LEAVE lamp (red):**
Lights up when you use HOME LEAVE Operation. (page 16.)

13. Indoor unit ON/OFF switch: (page 10.)

- Push this switch once to start operation. Push once again to stop it.
- The operation mode refers to the following table.

	Mode	Temperature setting	Air flow rate
FLKS	COOL	22°C	AUTO
FLXS	AUTO	25°C	AUTO

- Push the switch using an object with a sharp tip, such as a pen.
- This switch is useful when the remote controller is missing.

14. Signal receiver:

- It receives signals from the remote controller.
- When the unit receives a signal, you will hear a short beep.
 - Operation startbeep-beep
 - Settings changedbeep
 - Operation stopbeeeeeeep

■ Outdoor Unit

15. **Air inlet:** (Back and side)
16. **Air outlet**
17. **Refrigerant piping and inter-unit cable**

18. Drain hose

19. Earth terminal:

- It is inside of this cover.

Appearance of the outdoor unit may differ from some models.

■ Remote Controller

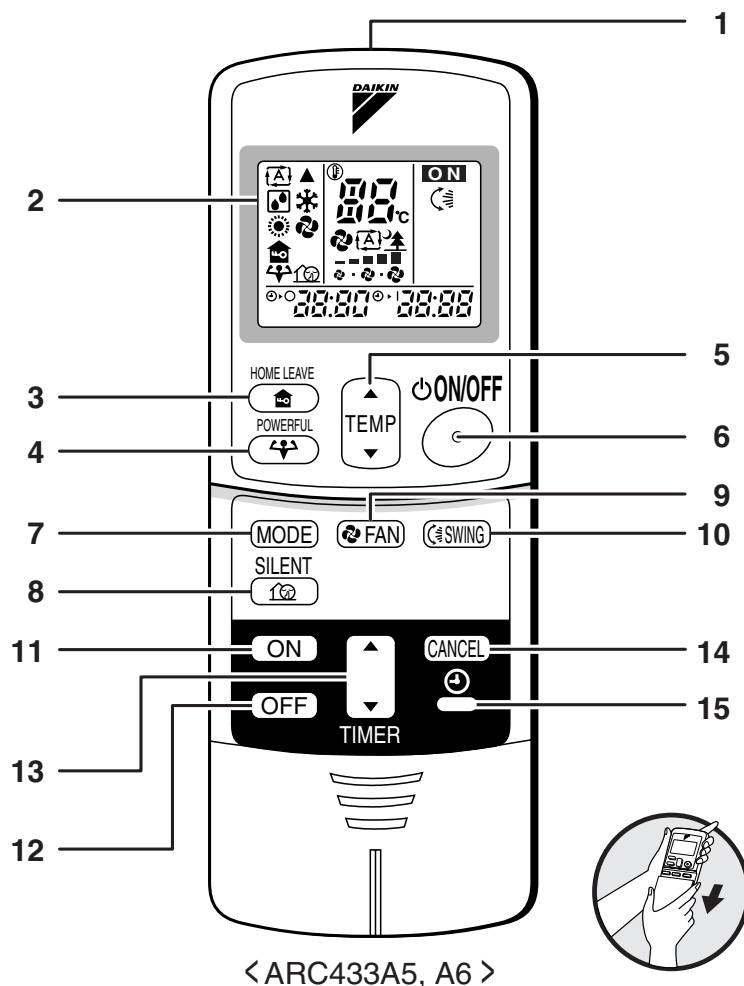

1. Signal transmitter:

- It sends signals to the indoor unit.

2. Display:

- It displays the current settings.
(In this illustration, each section is shown with all its displays ON for the purpose of explanation.)

3. HOME LEAVE button:

for HOME LEAVE operation (page 16.)

4. POWERFUL button:

for POWERFUL operation (page 14.)

5. TEMPERATURE adjustment buttons:

- It changes the temperature setting.

6. ON/OFF button:

- Press this button once to start operation.
Press once again to stop it.

7. MODE selector button:

- It selects the operation mode.
(AUTO/DRY/COOL/HEAT/FAN) (page 10.)

8. OUTDOOR UNIT SILENT button: (page 15.)

9. FAN setting button:

- It selects the air flow rate setting.

10. SWING button: (page 12.)

11. ON TIMER button: (page 19.)

12. OFF TIMER button: (page 18.)

13. TIMER Setting button:

- It changes the time setting.

14. TIMER CANCEL button:

- It cancels the timer setting.

15. CLOCK button: (page 9)

2.3 Preparation before Operation

Preparation Before Operation

■ To set the batteries

1. Press  with a finger and slide the front cover to take it off.
2. Set two dry batteries (AAA).
3. Set the front cover as before.

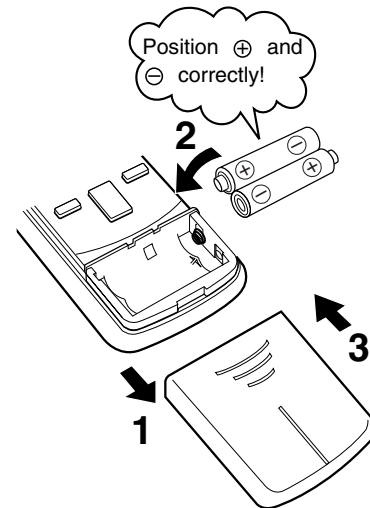

ATTENTION

■ About batteries

- When replacing the batteries, use batteries of the same type, and replace the two old batteries together.
- When the system is not used for a long time, take the batteries out.
- We recommend replacing once a year, although if the remote controller display begins to fade or if reception deteriorates, please replace with new alkali batteries. Using manganese batteries reduces the lifespan.
- The attached batteries are provided for the initial use of the system.
The usable period of the batteries may be short depending on the manufactured date of the air conditioner.

Preparation Before Operation

■ To operate the remote controller

- To use the remote controller, aim the transmitter at the indoor unit. If there is anything to block signals between the unit and the remote controller, such as a curtain, the unit will not operate.
- Do not drop the remote controller. Do not get it wet.
- The maximum distance for communication is about 4 m.

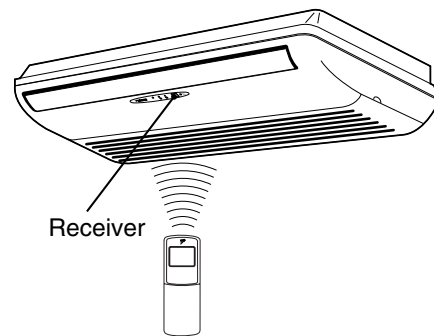

■ To fix the remote controller holder on the wall

1. Choose a place from where the signals reach the unit.
2. Fix the holder to a wall, a pillar, or similar location with the screws procured locally.
3. Place the remote controller in the remote controller holder.

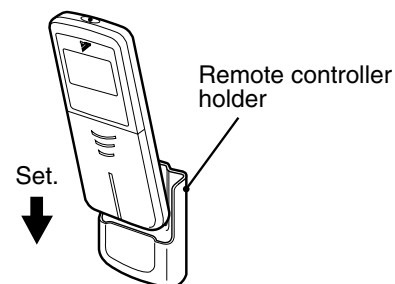

- To remove, pull it upwards.

ATTENTION

■ About remote controller

- Never expose the remote controller to direct sunlight.
- Dust on the signal transmitter or receiver will reduce the sensitivity. Wipe off dust with soft cloth.
- Signal communication may be disabled if an electronic-starter-type fluorescent lamp (such as inverter-type lamps) is in the room. Consult the shop if that is the case.
- If the remote controller signals happen to operate another appliance, move that appliance to somewhere else, or consult the shop.

■ To set the clock

1. Press “CLOCK button”.

0:00 is displayed.

⌚ blinks.

2. Press “TIMER setting button” to set the clock to the present time.

Holding down “▲” or “▼” button rapidly increases or decreases the time display.

3. Press “CLOCK button”.

⌚ blinks.

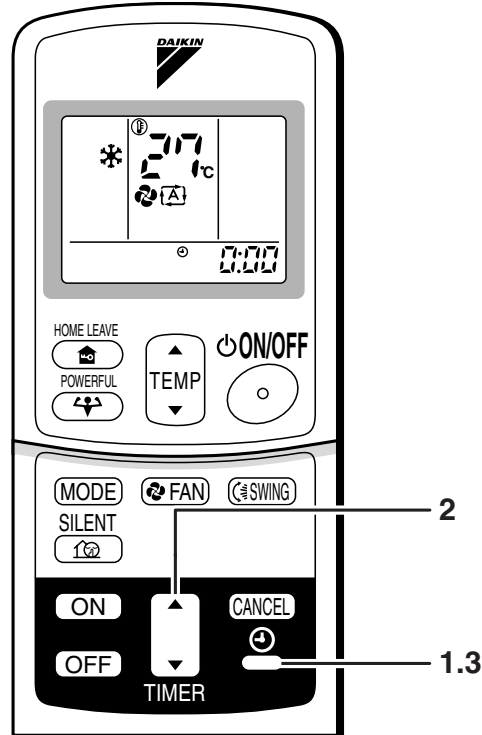

■ Turn the breaker ON

- Turning ON the breaker opens the flap, then closes it again. (This is a normal procedure.)

NOTE

■ Tips for saving energy

- Be careful not to cool (heat) the room too much. Keeping the temperature setting at a moderate level helps save energy.
- Cover windows with a blind or a curtain. Blocking sunlight and air from outdoors increases the cooling (heating) effect.
- Clogged air filters cause inefficient operation and waste energy. Clean them once in about every two weeks.

Recommended temperature setting
For cooling: 26°C – 28°C
For heating: 20°C – 24°C

■ Please note

- The air conditioner always consumes 15-35 watts of electricity even while it is not operating.
- If you are not going to use the air conditioner for a long period, for example in spring or autumn, turn the breaker OFF.
- Use the air conditioner in the following conditions.

Mode	Operating conditions	If operation is continued out of this range
COOL	Outdoor temperature: <2MK(X)S>-10 to 46 °C <3/4MK(X)S>-10 to 46 °C <RK(X)S>-10 to 46 °C Indoor temperature: 18 to 32 °C Indoor humidity: 80% max.	<ul style="list-style-type: none"> • A safety device may work to stop the operation. (In multi system, it may work to stop the operation of the outdoor unit only.) • Condensation may occur on the indoor unit and drip.
HEAT	Outdoor temperature: <2MXS>-10 to 21 °C <3/4MXS>-15 to 21 °C <RXS>-15 to 21 °C Indoor temperature: 10 to 30 °C	<ul style="list-style-type: none"> • A safety device may work to stop the operation.
DRY	Outdoor temperature: <2MK(X)S>-10 to 46 °C <3/4MK(X)S>-10 to 46 °C <RK(X)S>-10 to 46 °C Indoor temperature: 18 to 32 °C Indoor humidity: 80% max.	<ul style="list-style-type: none"> • A safety device may work to stop the operation. • Condensation may occur on the indoor unit and drip.

- Operation outside this humidity or temperature range may cause a safety device to disable the system.

2.4 AUTO · DRY · COOL · HEAT · FAN Operation

AUTO · DRY · COOL · HEAT · FAN Operation

The air conditioner operates with the operation mode of your choice.
 From the next time on, the air conditioner will operate with the same operation mode.

■ To start operation

1. Press “MODE selector button” and select a operation mode.

- Each pressing of the button advances the mode setting in sequence.

: AUTO

: DRY

: COOL

: HEAT

: FAN

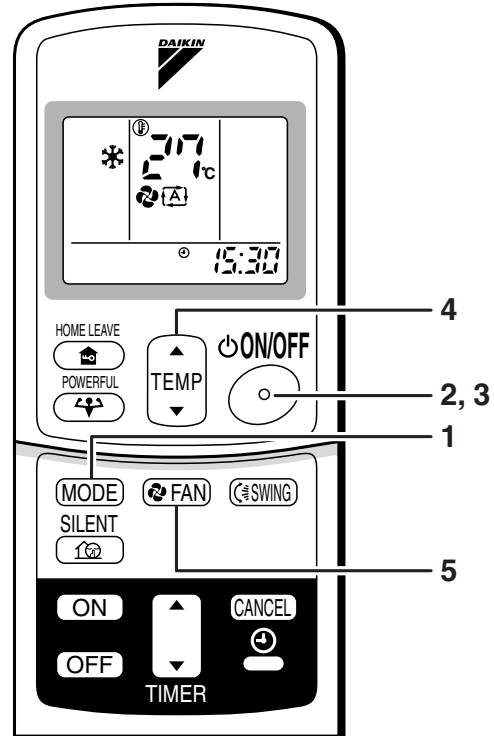
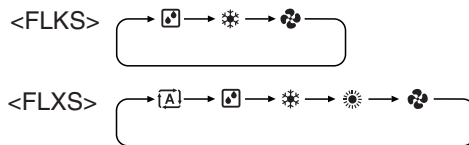

2. Press “ON/OFF button” .

- The OPERATION lamp lights up.

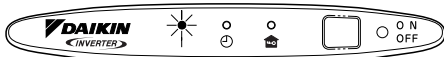

■ To stop operation

3. Press “ON/OFF button” again.

- Then OPERATION lamp goes off.





■ To change the temperature setting

4. Press “TEMPERATURE adjustment button”

DRY or FAN mode	AUTO or COOL or HEAT mode
The temperature setting is not variable.	Press “▲” to raise the temperature and press “▼” to lower the temperature.
	Set to the temperature you like.

■ To change the air flow rate setting

5. Press “FAN setting button”.

DRY mode	AUTO or COOL or HEAT or FAN mode
The air flow rate setting is not variable.	Five levels of air flow rate setting from “  ” to “  ” plus “  ” “  ” are available. 

- Indoor unit quiet operation

When the air flow is set to “”, the noise from the indoor unit will become quieter.

Use this when making the noise quieter.

The unit might lose capacity when the air flow rate is set to a weak level.

NOTE

■ Note on HEAT operation

- Since this air conditioner heats the room by taking heat from outdoor air to indoors, the heating capacity becomes smaller in lower outdoor temperatures. If the heating effect is insufficient, it is recommended to use another heating appliance in combination with the air conditioner.
- The heat pump system heats the room by circulating hot air around all parts of the room. After the start of heating operation, it takes some time before the room gets warmer.
- In heating operation, frost may occur on the outdoor unit and lower the heating capacity. In that case, the system switches into defrosting operation to take away the frost.
- During defrosting operation, hot air does not flow out of indoor unit.

■ Note on DRY operation

- The computer chip works to rid the room of humidity while maintaining the temperature as much as possible. It automatically controls temperature and fan strength, so manual adjustment of these functions is unavailable.

■ Note on AUTO operation

- In AUTO operation, the system selects a temperature setting and an appropriate operation mode (COOL or HEAT) based on the room temperature at the start of the operation.
- The system automatically reselects setting at a regular interval to bring the room temperature to user-setting level.
- If you do not like AUTO operation, you can manually select the operation mode and setting you like.

■ Note on air flow rate setting

- At smaller air flow rates, the cooling (heating) effect is also smaller.

2.5 Adjusting the Air Flow Direction

Adjusting the Air Flow Direction

You can adjust the air flow direction to increase your comfort.

■ To adjust the horizontal blade (flap)

1. Press “SWING button”.

 The display will light up and the flaps will begin to swing.

2. When the flaps have reached the desired position, press “SWING button” once more.

The display will go blank.
The flaps will stop moving.

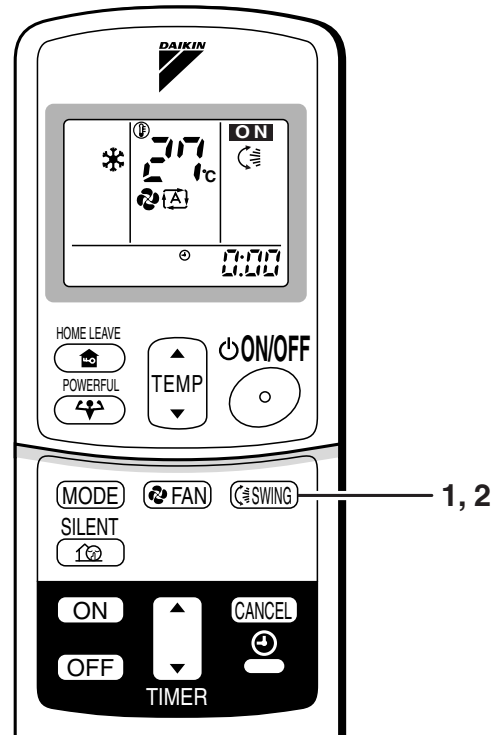

■ To adjust the vertical blades (louvers)

- When adjusting the louver, use a robust and stable stool and watch your steps carefully.
Hold the knob and move the louvers.
(You will find a knob on the left side and the right side blades.)

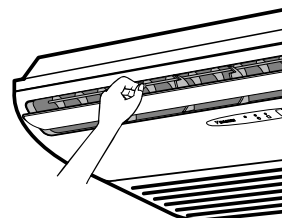

Notes on flap and louvers angles

- Unless [SWING] is selected, you should set the flap at a near- horizontal angle in COOL or DRY mode to obtain the best performance.
- In COOL or DRY mode, if the flap is fixed at a downward position, the flap automatically moves in about 60 minutes to prevent condensation on it.

■ ATTENTION

- Always use a remote controller to adjust the flap angle.
If you attempt to move it forcibly with hand when it is swinging, the mechanism may be broken.
- Be careful when adjusting the louvers. Inside the air outlet, a fan is rotating at a high speed.

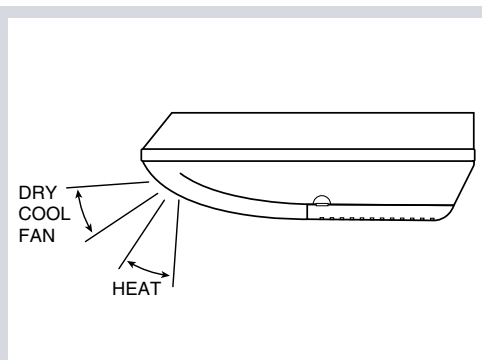

2.6 POWERFUL Operation

POWERFUL Operation

POWERFUL operation quickly maximizes the cooling (heating) effect in any operation mode. You can get the maximum capacity .

■ To start POWERFUL operation

1. Press “POWERFUL button”.
 - POWERFUL operation ends in 20 minutes. Then the system automatically operates again with the settings which were used before POWERFUL operation.
 - When using POWERFUL operation, there are some functions which are not available.

■ To cancel POWERFUL operation

2. Press “POWERFUL button” again.

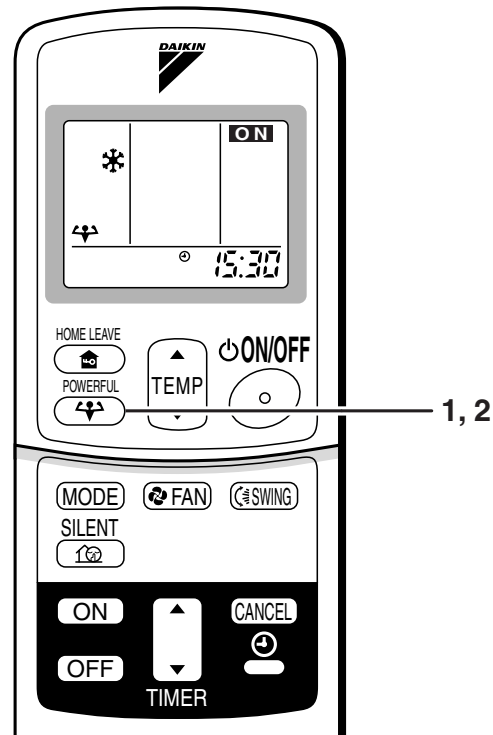

NOTE

- Notes on POWERFUL operation
 - In COOL and HEAT mode
 - To maximize the cooling (heating) effect, the capacity of outdoor unit must be increased and the air flow rate be fixed to the maximum setting.
 - The temperature and air flow settings are not variable.
 - In DRY mode
 - The temperature setting is lowered by 2.5°C and the air flow rate is slightly increased.
 - In FAN mode
 - The air flow rate is fixed to the maximum setting.

2.7 OUTDOOR UNIT SILENT Operation

OUTDOOR UNIT SILENT Operation

OUTDOOR UNIT SILENT operation lowers the noise level of the outdoor unit by changing the frequency and fan speed on the outdoor unit. This function is convenient during night.

■ To start OUTDOOR UNIT SILENT operation

1. Press “SILENT button”.

■ To cancel OUTDOOR UNIT SILENT operation

2. Press “SILENT button” again.

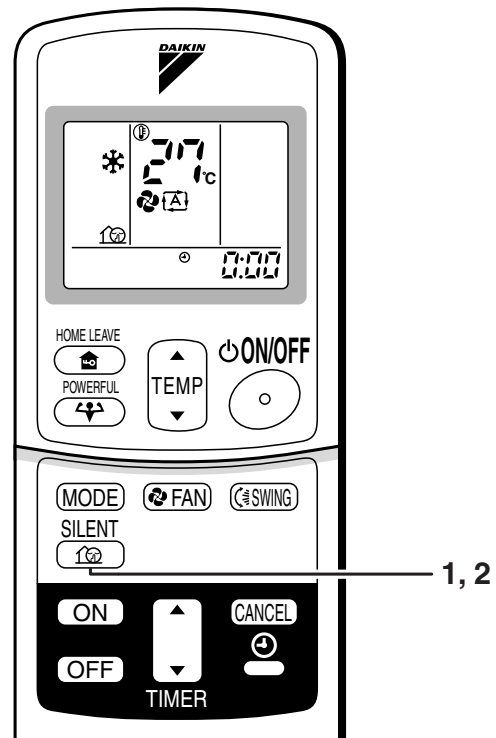

NOTE

■ Note on OUTDOOR UNIT SILENT operation

- This function is available in COOL, HEAT, and AUTO modes. (This is not available in FAN and DRY mode.)
- POWERFUL operation and OUTDOOR UNIT SILENT operation cannot be used at the same time. Priority is given to POWERFUL operation.
- If operation is stopped using the remote controller or the main unit ON/OFF switch when using OUTDOOR UNIT SILENT operation, “” will remain on the remote controller display.

2.8 HOME LEAVE Operation

HOME LEAVE Operation

HOME LEAVE operation is a function which allows you to record your preferred temperature and air flow rate settings.

■ To start HOME LEAVE operation

1. Press “HOME LEAVE button” .
 - The HOME LEAVE lamp lights up.

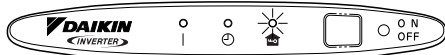

■ To cancel HOME LEAVE operation

2. Press “HOME LEAVE button” again.
 - The HOME LEAVE lamp goes off.

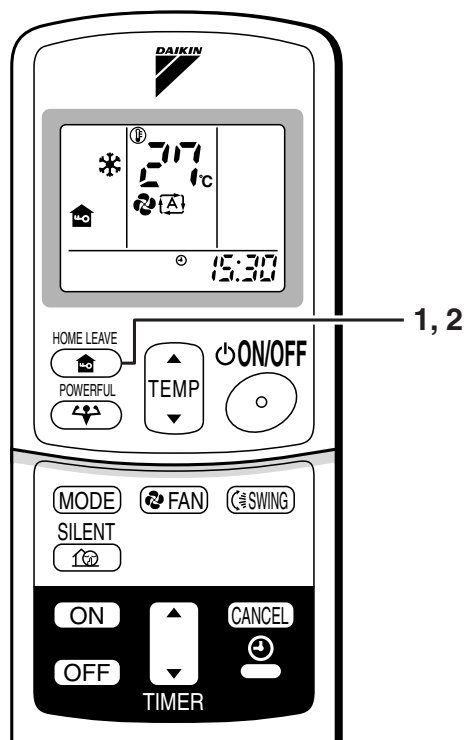

Before using HOME LEAVE operation.

■ To set the temperature and air flow rate for HOME LEAVE operation

When using HOME LEAVE operation for the first time, please set the temperature and air flow rate for HOME LEAVE operation. Record your preferred temperature and air flow rate.

	Initial setting		Selectable range	
	temperature	Air flow rate	temperature	Air flow rate
Cooling	25°C	AUTO	18-32°C	5 step, AUTO and SILENT
Heating	25°C	AUTO	10-30°C	5 step, AUTO and SILENT

1. Press “HOME LEAVE button”. Make sure “” is displayed in the remote controller display.
2. Adjust the set temperature with “▲” or “▼” as you like.
3. Adjust the air flow rate with “FAN” setting button as you like.

Home leave operation will run with these settings the next time you use the unit. To change the recorded information, repeat steps 1 – 3.

■ What's the HOME LEAVE operation

Is there a set temperature and air flow rate which is most comfortable, a set temperature and air flow rate which you use the most? HOME LEAVE operation is a function that allows you to record your favorite set temperature and air flow rate. You can start your favorite operation mode simply by pressing the HOME LEAVE button on the remote controller. This function is convenient in the following situations.

■ Useful in these cases.

1. Use as an energy-saving mode

Set the temperature 2-3°C higher (cooling) or lower (heating) than normal. Setting the fan strength to the lowest setting allows the unit to be used in energy-saving mode. Also convenient for use while you are out or sleeping.

• Every day before you leave the house...



When you go out, push the "HOME LEAVE Operation" button, and the air conditioner will adjust capacity to reach the preset temperature for HOME LEAVE Operation.



When you return, you will be welcomed by a comfortably air conditioned room.

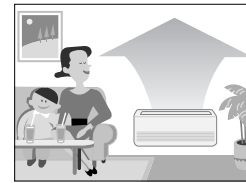

Push the "HOME LEAVE Operation" button again, and the air conditioner will adjust capacity to the set temperature for normal operation.

• Before bed...

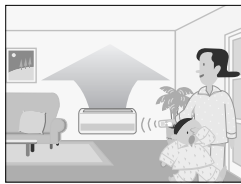

Set the unit to HOME LEAVE Operation before leaving the living room when going to bed.



The unit will maintain the temperature in the room at a comfortable level while you sleep.

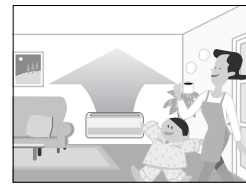

When you enter the living room in the morning, the temperature will be just right. Disengaging HOME LEAVE Operation will return the temperature to that set for normal operation. Even the coldest winters will pose no problem!

2. Use as a favorite mode

Once you record the temperature and air flow rate settings you most often use, you can retrieve them by pressing HOME LEAVE button. You do not have to go through troublesome remote control operations.

NOTE

- Once the temperature and air flow rate for HOME LEAVE operation are set, those settings will be used whenever HOME LEAVE operation is used in the future. To change these settings, please refer to the "Before using HOME LEAVE operation" section above.
- HOME LEAVE operation is only available in COOL and HEAT mode. Cannot be used in AUTO, DRY, and FAN mode.
- HOME LEAVE operation runs in accordance with the previous operation mode (COOL or HEAT) before using HOME LEAVE operation.
- HOME LEAVE operation and POWERFUL operation cannot be used at the same time. Last button that was pressed has priority.
- The operation mode cannot be changed while HOME LEAVE operation is being used.
- When operation is shut off during HOME LEAVE operation, using the remote controller or the indoor unit ON/OFF switch, "🏠" will remain on the remote controller display.

2.9 TIMER Operation

TIMER Operation

Timer functions are useful for automatically switching the air conditioner on or off at night or in the morning. You can also use OFF TIMER and ON TIMER in combination.

■ To use OFF TIMER operation

- Check that the clock is correct.
If not, set the clock to the present time.
(page 9.)

1. Press “OFF TIMER button”.

0:00 is displayed.

⊕-⊖ blinks.

2. Press “TIMER Setting button” until the time setting reaches the point you like.

- Every pressing of either button increases or decreases the time setting by 10 minutes. Holding down either button changes the setting rapidly.

3. Press “OFF TIMER button” again.

- The TIMER lamp lights up.

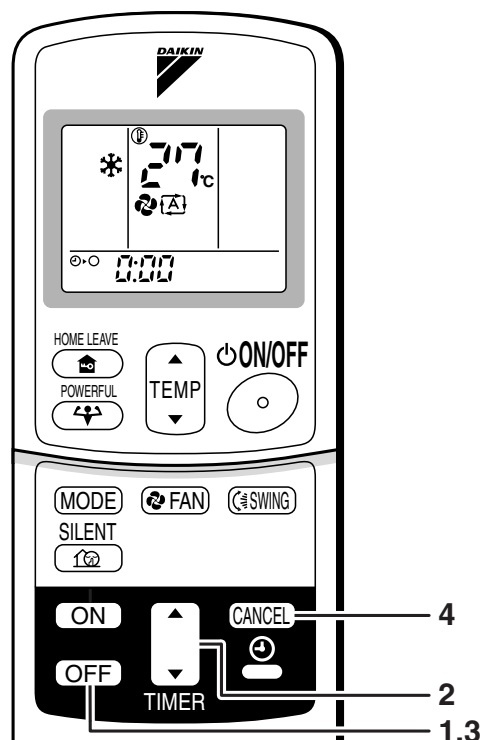
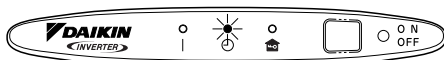

■ To cancel the OFF TIMER operation

4. Press “CANCEL button”.

- The TIMER lamp goes off.

Notes

- When TIMER is set, the present time is not displayed.
- Once you set ON, OFF TIMER, the time setting is kept in the memory. (The memory is canceled when remote controller batteries are replaced.)
- When operating the unit via the ON/OFF Timer, the actual length of operation may vary from the time entered by the user. (Maximum approx. 10 minutes)

■ NIGHT SET MODE

When the OFF TIMER is set, the air conditioner automatically adjusts the temperature setting (0.5°C up in COOL, 2.0°C down in HEAT) to prevent excessive cooling (heating) for your pleasant sleep.

■ To use ON TIMER operation

- Check that the clock is correct. If not, set the clock to the present time (page 9.).

1. Press “ON TIMER button”.

6:00 is displayed.

⊕-| blinks.

2. Press “TIMER Setting button” until the time setting reaches the point you like.

- Every pressing of either button increases or decreases the time setting by 10 minutes. Holding down either button changes the setting rapidly.

3. Press “ON TIMER button” again.

- The TIMER lamp lights up.

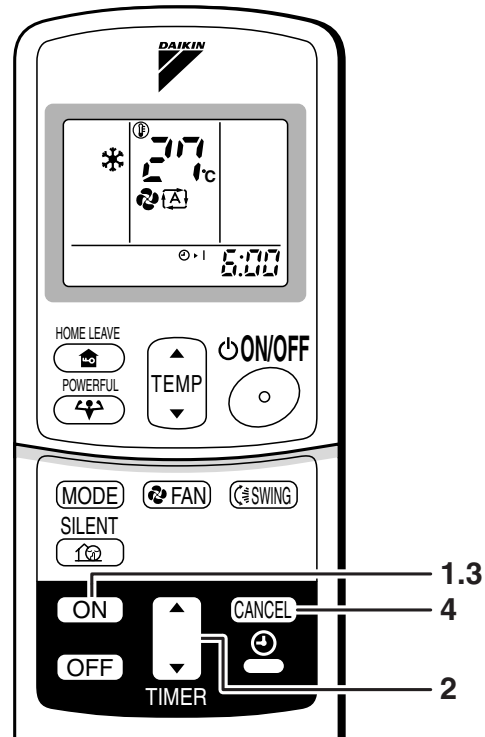
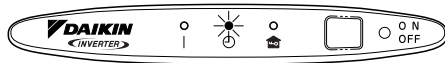

■ To cancel ON TIMER operation

4. Press “CANCEL button”.

- The TIMER lamp goes off.

■ To combine ON TIMER and OFF TIMER

- A sample setting for combining the two timers is shown below.

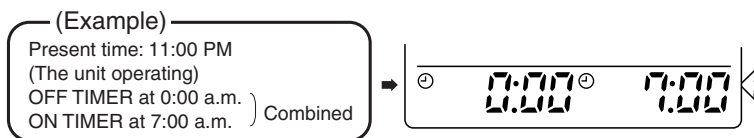

ATTENTION

- In the following cases, set the timer again.
 - After a breaker has turned OFF.
 - After a power failure.
 - After replacing batteries in the remote controller.

2.10 Care and Cleaning

Care and Cleaning



CAUTION Before cleaning, be sure to stop the operation and turn the breaker OFF.

Units

■ Indoor unit, Outdoor unit and Remote controller

1. Wipe them with dry soft cloth.

■ Front grille

1. Open the front grille.

- Hold the grille by the tabs on the two sides and lift it until it stops.

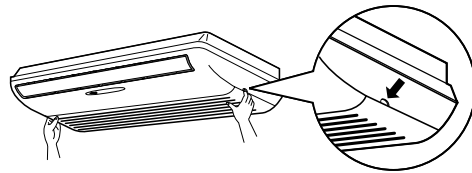

2. Clean the front grille

- Wipe it with a soft cloth soaked in water.
- Only neutral detergent may be used.
- In case of washing the grille with water, dry it with cloth, dry it up in the shade after washing.

3. Close the front grille

- Push the grille at the 5 points indicated by ↑.
- Operation without air filters may result in troubles as dust will accumulate inside the indoor unit.

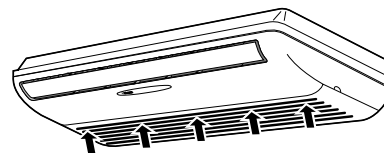

CAUTION

- Don't touch the metal parts of the indoor unit. If you touch those parts, this may cause an injury.
- When opening and closing the front grille, use a robust and stable stool and watch your steps carefully.
- When opening and closing the front grille, support the grille securely with hand to prevent it from falling.
- For cleaning, do not use hot water above 40 °C, benzene, gasoline, thinner, nor other volatile oils, polishing compound, scrubbing brushes, nor other hand stuff.
- After cleaning, make sure that the front grille is securely fixed.

Filters

1. **Open the front grille. (page 22)**
2. **Pull out the air filters.**
 - Push upwards the tab at the center of each air filter, then pull it down.

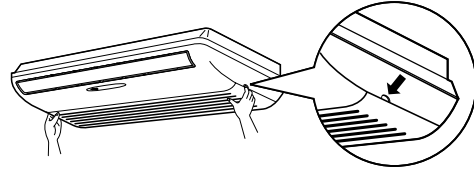

3. **Take off the air purifying filter, photocatalytic deodorizing filter.**
 - Hold the recessed parts of the frame and unhook the four claws.

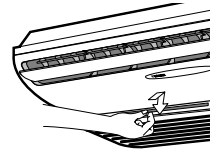

4. **Clean or replace each filter.**
See figure.

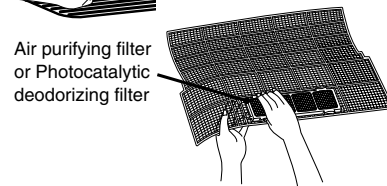

5. **Set the air filter, air purifying filter and photocatalytic deodorizing filter as they were and close the front grille.**
 - Insert claws of the filters into slots of the front panel.
 - Push the grille at the 5 points.

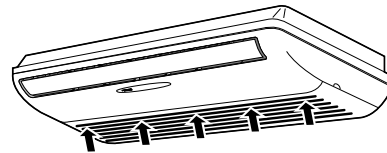

■ Air Filter

1. **Wash the air filters with water or clean them with vacuum cleaner.**
 - If the dust does not come off easily, wash them with neutral detergent thinned with lukewarm water, then dry them up in the shade.
 - It is recommended to clean the air filters every two weeks.

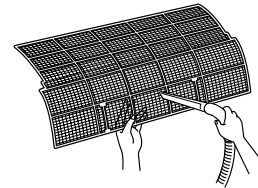

■ Air Purifying Filter (green)

(Replace approximately once every 3 months.)

1. **Detach the filter element and attach a new one.**
 - Insert with the green side up.
 - It is recommended to replace the air purifying filter every three months.

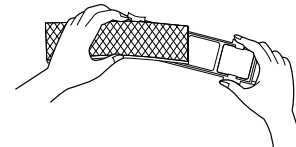

■ Photocatalytic Deodorizing Filter (gray)

[Maintenance]

1. **Dry the photocatalytic deodorizing filter in the sun.**
 - After removing the dust with a vacuum cleaner, place the filter in the sun for approximately 6 hours. By drying the photocatalytic deodorizing filter in the sun, its deodorizing and antibacterial capabilities are regenerated.
 - Because the filter material is paper, it can not be cleaned with water.
 - It is recommended dry the filter once every 6 months.

[Replacement]

1. **Detach the filter element and attach a new one.**

Check

Check that the base, stand and other fittings of the outdoor unit are not decayed or corroded.
Check that nothing blocks the air inlets and the outlets of the indoor unit and the outdoor unit.
Check that the drain comes smoothly out of the drain hose during COOL or DRY operation. If no drain water is seen, water may be leaking from the indoor unit. Stop operation and consult the service shop if this is the case.

■ Before a long idle period

1. Operate the “FAN only” for several hours on a fine day to dry out the inside.
 - Press “MODE” button and select “FAN” operation.
 - Press “ON/OFF” button and start operation.
2. After operation stops, turn off the breaker for the room air conditioner.
3. Clean the air filters and set them again.
4. Take out batteries from the remote controller.

NOTE

- Operation with dirty filters :
 - (1) cannot deodorize the air. (2) cannot clean the air.
 - (3) results in poor heating or cooling. (4) may cause odour.
- The air purifying filter and Photocatalytic deodorizing filter cannot be reused, even if washed.
- In principle, there is no need to replace the photocatalytic deodorizing filter. Remove the dust periodically with a vacuum cleaner. However, it is recommended to replace the filter in the following cases.
 - (1) The paper material is torn or broken during cleaning.
 - (2) The filter has become extremely dirty after long use.
- To order air purifying filter or Photocatalytic deodorizing filter, contact to the service shop where you bought the air conditioner.
- Dispose of old air filters as non-burnable waste and Photocatalytic deodorizing filters as burnable waste.

Item	Part No.
Photocatalytic deodorizing filter (with frame)	KAZ917B41
Photocatalytic deodorizing filter (without frame)	KAZ917B42
Air purifying filter (with frame)	KAF925B41
Air purifying filter (without frame)	KAF925B42

2.11 Troubleshooting

Trouble Shooting

These cases are not troubles.

The following cases are not air conditioner troubles but have some reasons. You may just continue using it.

Case	Explanation
Operation does not start soon. <ul style="list-style-type: none"> When ON/OFF button was pressed soon after operation was stopped. When the mode was reselected. 	<ul style="list-style-type: none"> This is to protect the air conditioner. You should wait for about 3 minutes.
Hot air does not flow out soon after the start of heating operation.	<ul style="list-style-type: none"> The air conditioner is warming up. You should wait for 1 to 4 minutes. (The system is designed to start discharging air only after it has reached a certain temperature.)
The heating operation stops suddenly and a flowing sound is heard.	<ul style="list-style-type: none"> The system is taking away the frost on the outdoor unit. You should wait for about 3 to 8 minutes.
The outdoor unit emits water or steam.	<ul style="list-style-type: none"> In HEAT mode <ul style="list-style-type: none"> The frost on the outdoor unit melts into water or steam when the air conditioner is in defrost operation. In COOL or DRY mode <ul style="list-style-type: none"> Moisture in the air condenses into water on the cool surface of outdoor unit piping and drips.
Mists come out of the indoor unit.	<ul style="list-style-type: none"> This happens when the air in the room is cooled into mist by the cold air flow during cooling operation.
The indoor unit gives out odour.	<ul style="list-style-type: none"> This happens when smells of the room, furniture, or cigarettes are absorbed into the unit and discharged with the air flow. (If this happens, we recommend you to have the indoor unit washed by a technician. Consult the service shop where you bought the air conditioner.)
The outdoor fan rotates while the air conditioner is not in operation.	<ul style="list-style-type: none"> After operation is stopped: <ul style="list-style-type: none"> The outdoor fan continues rotating for another 60 seconds for system protection. While the air conditioner is not in operation: <ul style="list-style-type: none"> When the outdoor temperature is very high, the out door fan starts rotating for system protection.
The operation stopped suddenly. (OPERATION lamp is on)	<ul style="list-style-type: none"> For system protection, the air conditioner may stop operating on a sudden large voltage fluctuation. It automatically resumes operation in about 3 minutes.

Check again.

Please check again before calling a repair person.

Case	Check
The air conditioner does not operate. (OPERATION lamp is off)	<ul style="list-style-type: none"> • Hasn't a breaker turned OFF or a fuse blown? • Isn't it a power failure? • Are batteries set in the remote controller? • Is the timer setting correct?
Cooling (Heating) effect is poor.	<ul style="list-style-type: none"> • Are the air filters clean? • Is there anything to block the air inlet or the outlet of the indoor and the outdoor units? • Is the temperature setting appropriate? • Are the windows and doors closed? • Are the air flow rate and the air direction set appropriately?
Operation stops suddenly. (OPERATION lamp blinks.)	<ul style="list-style-type: none"> • Are the air filters clean? • Is there anything to block the air inlet or the outlet of the indoor and the outdoor units? <p>Clean the air filters or take all obstacles away and turn the breaker OFF. Then turn it ON again and try operating the air conditioner with the remote controller. If the lamp still blinks, call the service shop where you bought the air conditioner.</p>
An abnormal functioning happens during operation.	<ul style="list-style-type: none"> • The air conditioner may malfunction with lightning or radio waves. Turn the breaker OFF, turn it ON again and try operating the air conditioner with the remote controller.

Call the service shop immediately.

 **WARNING**

- When an abnormality (such as a burning smell) occurs, stop operation and turn the breaker OFF. Continued operation in an abnormal condition may result in troubles, electric shocks or fire. Consult the service shop where you bought the air conditioner.
- Do not attempt to repair or modify the air conditioner by yourself. Incorrect work may result in electric shocks or fire. Consult the service shop where you bought the air conditioner.

If one of the following symptoms takes place, call the service shop immediately.

<ul style="list-style-type: none"> ■ The power cord is abnormally hot or damaged. ■ An abnormal sound is heard during operation. ■ The safety breaker, a fuse, or the earth leakage breaker cuts off the operation frequently. ■ A switch or a button often fails to work properly. ■ There is a burning smell. ■ Water leaks from the indoor unit. 	 <div data-bbox="1082 725 1313 967" style="border: 1px solid black; padding: 10px; width: fit-content; margin: 0 auto;"> Turn the breaker OFF and call the service shop. </div>
---	--

<ul style="list-style-type: none"> ■ After a power failure The air conditioner automatically resumes operation in about 3 minutes. You should just wait for a while. 	<ul style="list-style-type: none"> ■ Lightning If lightning may strike the neighbouring area, stop operation and turn the breaker OFF for system protection.
--	--

Disposal requirements



Your air conditioning product is marked with this symbol. This means that electrical and electronic products shall not be mixed with unsorted household waste.

Do not try to dismantle the system yourself: the dismantling of the air conditioning system, treatment of the refrigerant, of oil and of other parts must be done by a qualified installer in accordance with relevant local and national legislation.

Air conditioners must be treated at a specialized treatment facility for re-use, recycling and recovery. By ensuring this product is disposed of correctly, you will help to prevent potential negative consequences for the environment and human health. Please contact the installer or local authority for more information.

Batteries must be removed from the remote controller and disposed of separately in accordance with relevant local and national legislation.

We recommend periodical maintenance

In certain operating conditions, the inside of the air conditioner may get foul after several seasons of use, resulting in poor performance. It is recommended to have periodical maintenance by a specialist aside from regular cleaning by the user. For specialist maintenance, contact the service shop where you bought the air conditioner.

The maintenance cost must be born by the user.

Fault diagnosis

FAULT DIAGNOSIS BY REMOTE CONTROLLER

In the ARC433A series, the temperature display sections on the main unit indicate corresponding codes.

1. When the **TIMER CANCEL** button is held down for 5 seconds, a “00” indication flashes on the temperature display section.

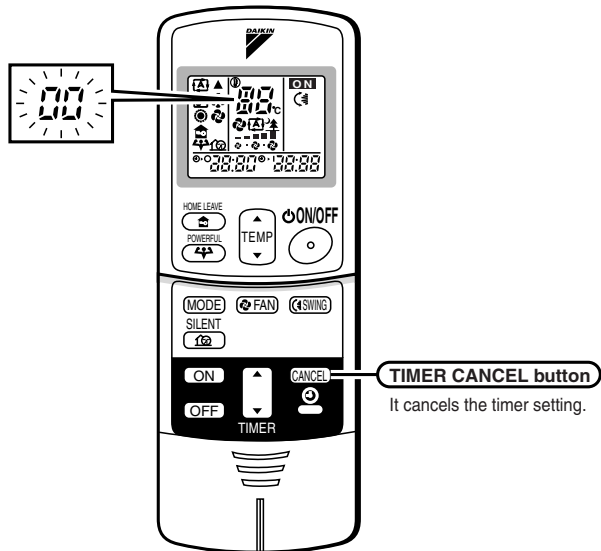

2. Press the **TIMER CANCEL** button repeatedly until a continuous beep is produced.

- The code indication changes as shown below, and notifies with a long beep.

	CODE	MEANING
SYSTEM	00	NORMAL
	U0	REFRIGERANT SHORTAGE
	U2	DROP VOLTAGE OR MAIN CIRCUIT OVERVOLTAGE
	U4	FAILURE OF TRANSMISSION (BETWEEN INDOOR UNIT AND OUTDOOR UNIT)
INDOOR UNIT	A1	INDOOR PCB DEFECTIVENESS
	A5	HIGH PRESSURE CONTROL OR FREEZE-UP PROTECTOR
	A6	FAN MOTOR FAULT
	C4	FAULTY HEAT EXCHANGER TEMPERATURE SENSOR
OUTDOOR UNIT	C9	FAULTY SUCTION AIR TEMPERATURE SENSOR
	EA	COOLING-HEATING SWITCHING ERROR
	E5	OL STARTED
	E6	FAULTY COMPRESSOR START UP
	E7	DC FAN MOTOR FAULT
	E8	OPERATION HALT DUE TO DETECTION OF INPUT OVER CURRENT
	F3	HIGH TEMPERATURE DISCHARGE PIPE CONTROL
	F6	HIGH PRESSURE CONTROL (IN COOLING)
	H6	OPERATION HALT DUE TO FAULTY POSITION DETECTION SENSOR
	H8	CT ABNORMALITY
	H9	FAULTY SUCTION AIR TEMPERATURE SENSOR
	J3	FAULTY DISCHARGE PIPE TEMPERATURE SENSOR
	J6	FAULTY HEAT EXCHANGER TEMPERATURE SENSOR
	L4	HIGH TEMPERATURE AT INVERTER CIRCUIT HEATSINK
	L5	OUTPUT OVERCURRENT
P4	FAULTY INVERTER CIRCUIT HEATSINK TEMPERATURE SENSOR	

NOTE

1. A short beep and two consecutive beeps indicate non-corresponding codes.
2. To cancel the code display, hold the **TIMER CANCEL** button down for 5 seconds. The code display also cancel itself if the button is not pressed for 1 minute.

Part 6

Service Diagnosis

1. Caution for Diagnosis.....	76
2. Problem Symptoms and Measures	77
3. Service Check Function	78
4. Troubleshooting	81
4.1 Error Codes and Description	81
4.2 Indoor Unit PCB Abnormality	82
4.3 Freeze-up Protection Control or High Pressure Control.....	83
4.4 Fan Motor (AC Motor) or Related Abnormality.....	85
4.5 Thermistor or Related Abnormality (Indoor Unit).....	86
4.6 Signal Transmission Error (between Indoor and Outdoor Unit)	87
4.7 Unspecified Voltage (between Indoor and Outdoor Units)	88
4.8 Outdoor Unit PCB Abnormality.....	89
4.9 OL Activation (Compressor Overload)	90
4.10 Compressor Lock	91
4.11 DC Fan Lock	92
4.12 Input Over Current Detection	93
4.13 Four Way Valve Abnormality	94
4.14 Discharge Pipe Temperature Control.....	96
4.15 High Pressure Control in Cooling	97
4.16 Compressor System Sensor Abnormality	99
4.17 Position Sensor Abnormality	100
4.18 DC Voltage / Current Sensor Abnormality.....	101
4.19 Thermistor or Related Abnormality (Outdoor Unit).....	102
4.20 Electrical Box Temperature Rise.....	104
4.21 Radiation Fin Temperature Rise	106
4.22 Output Over Current Detection.....	108
4.23 Insufficient Gas.....	110
4.24 Over-voltage Detection.....	112
5. Check	113
5.1 How to Check.....	113

1. Caution for Diagnosis

The Operation lamp flashes when any of the following errors is detected.

1. When a protection device of the indoor or outdoor unit is activated or when the thermistor malfunctions, disabling equipment operation.
 2. When a signal transmission error occurs between the indoor and outdoor units.
- In either case, conduct the diagnostic procedure described in the following pages.

Location of Operation Lamp

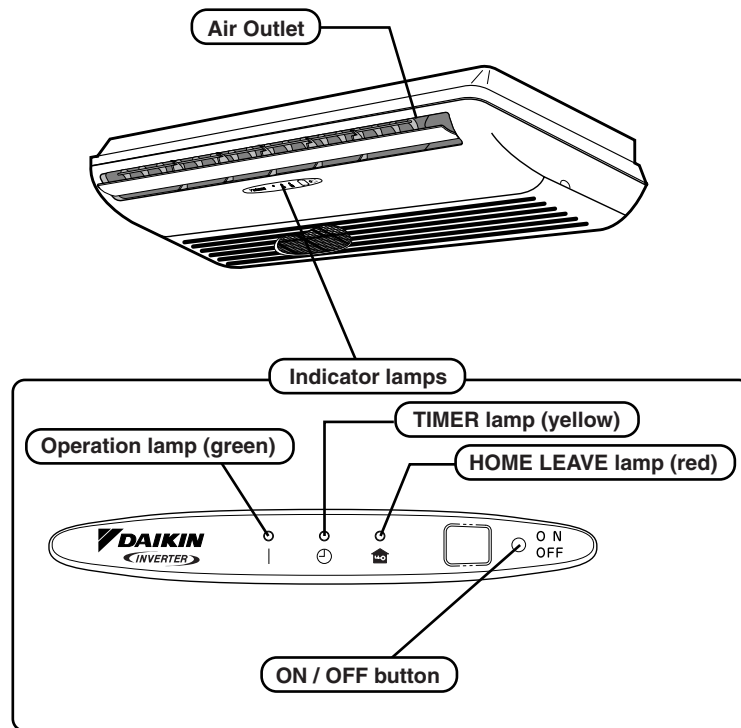

(R2974)

Troubleshooting with the LED Indication

The outdoor unit has one green LED (LED A) on the PCB. The flashing green LED indicates normal condition of microcomputer operation.

2. Problem Symptoms and Measures

Symptom	Check Item	Details of Measure	Reference Page
None of the Units Operates.	Check the power supply.	Check to make sure that the rated voltage is supplied.	—
	Check the type of the indoor units.	Check to make sure that the indoor unit type is compatible with the outdoor unit.	—
	Check the outdoor air temperature.	Heating operation cannot be used when the outdoor air temperature is 21°C or higher (only for heat pump model), and cooling operation cannot be used when the outdoor air temperature is below -10°C.	—
	Diagnosis with remote controller indication	—	81
	Check the remote controller addresses.	Check to make sure that address settings for the remote controller and indoor unit are correct.	—
Operation Sometimes Stops.	Check the power supply.	A power failure of 2 to 10 cycles can stop air conditioner operation. (Operation lamp OFF)	—
	Check the outdoor air temperature.	Heating operation cannot be used when the outdoor air temperature is 21°C or higher (only for heat pump model), and cooling operation cannot be used when the outdoor air temperature is below -10°C.	—
	Diagnosis with remote controller indication	—	81
Equipment operates but does not cool, or does not heat (only for heat pump model).	Check for wiring and piping errors in the indoor and outdoor units connection wires and pipes.	Conduct the wiring/piping error check described on the product diagnosis nameplate.	—
	Check for thermistor detection errors.	Check to make sure that the main unit's thermistor has not dismantled from the pipe holder.	—
	Check for faulty operation of the electronic expansion valve.	Set the units to cooling operation, and compare the temperatures of the liquid side connection pipes of the connection section among rooms to check the opening and closing operation of the electronic expansion valves of the individual units.	—
	Diagnosis with remote controller indication	—	81
	Diagnosis by service port pressure and operating current	Check for insufficient gas.	117
Large Operating Noise and Vibrations	Check the output voltage of the power transistor.	—	118
	Check the power transistor.	—	—
	Check the installation condition.	Check to make sure that the required spaces for installation (specified in the Technical Guide, etc.) are provided.	—

3. Service Check Function

In the **ARC433A** series remote controller, the temperature display sections on the main unit indicate corresponding codes.

Check Method 1

1. When the timer cancel button is held down for 5 seconds, a “00” indication flashes on the temperature display section.

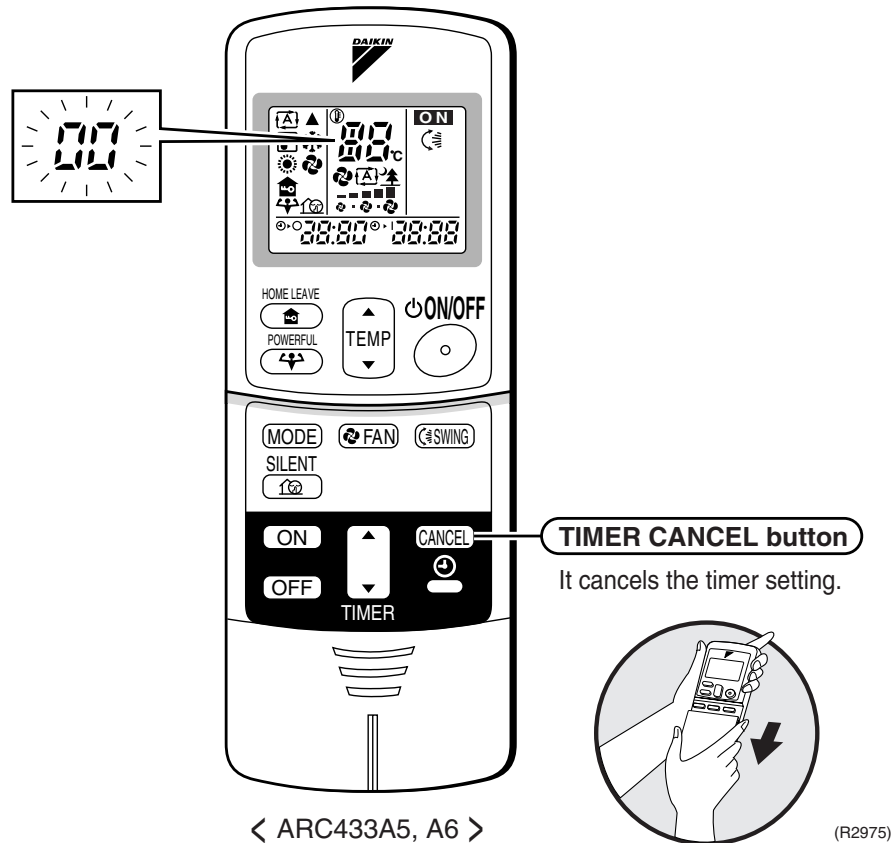

2. Press the timer cancel button repeatedly until a continuous beep is produced.
 - The code indication changes in the sequence shown below, and notifies with a long beep.

No.	Code	No.	Code	No.	Code
1	00	12	C7	23	H0
2	U4	13	H8	24	E1
3	F3	14	J3	25	P4
4	E6	15	R3	26	L3
5	L5	16	R1	27	L4
6	R6	17	C4	28	H6
7	E5	18	C5	29	H7
8	F6	19	H9	30	U2
9	C9	20	J6	31	UH
10	U0	21	UR	32	ER
11	E7	22	R5	33	RH



Note:

1. A short beep and two consecutive beeps indicate non-corresponding codes.
2. To cancel the code display, hold the timer cancel button down for 5 seconds. The code display also cancels itself if the button is not pressed for 1 minute.

Check Method 2

1. Enter the diagnosis mode.
Press the 3 buttons (TEMP▲,TEMP▼, MODE) simultaneously.

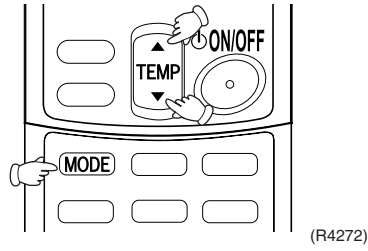

The digit of the number of tens blinks.

★Try again from the start when the digit does not blink.

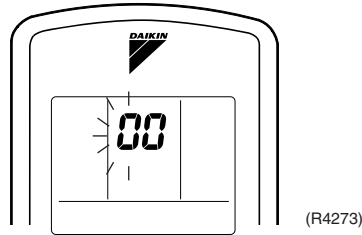

2. Press the TEMP button.
Press TEMP▲ or TEMP▼ and change the digit until you hear the sound of “beep” or “pi pi”.

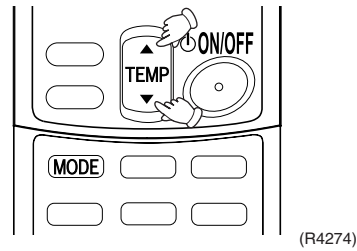

3. Diagnose by the sound.
 - ★“ pi ” : The number of tens does not accord with the error code.
 - ★“ pi pi ” : The number of tens accords with the error code.
 - ★“ beep ” : The both numbers of tens and units accord with the error code. (→See 7.)

4. Enter the diagnosis mode again.
Press the MODE button.

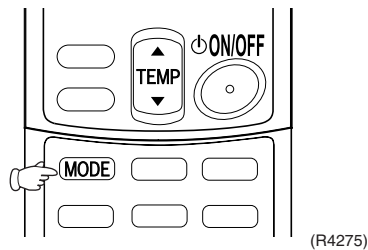

The digit of the number of units blinks.

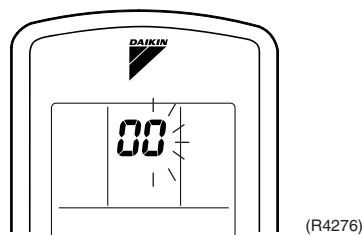

5. Press the TEMP button.
Press TEMP▲ or TEMP▼ and change the digit until you hear the sound of “beep”.

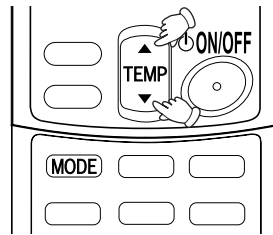

(R4277)

6. Diagnose by the sound.
 - ★“ pi ” : The both numbers of tens and units do not accord with the error code.
 - ★“ pi pi ” : The number of tens accords with the error code.
 - ★“ beep ” : The both numbers of tens and units accord with the error code.
7. Determine the error code.
The digits indicated when you hear the “beep” sound are error code.
(Error codes and description → Refer to page 81.)
8. Exit from the diagnosis mode.
Press the MODE button.

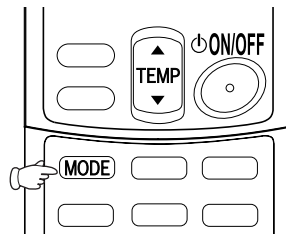

(R4278)

4. Troubleshooting

4.1 Error Codes and Description

	Code Indication	Description	Reference Page
System	<i>00</i>	Normal	—
	<i>U0</i> ★	Insufficient gas	110
	<i>U2</i>	Over-voltage detection	112
	<i>U4</i>	Signal transmission error (between indoor and outdoor unit)	87
	<i>UR</i>	Unspecified voltage (between indoor and outdoor unit)	88
Indoor Unit	<i>R1</i>	Indoor unit PCB abnormality	82
	<i>R5</i>	Freeze-up protection control or high pressure control	83
	<i>R6</i>	Fan motor or related abnormality	85
	<i>C4</i>	Heat exchanger temperature thermistor abnormality	86
	<i>C9</i>	Room temperature thermistor abnormality	86
Outdoor Unit	<i>E1</i>	Outdoor unit PCB abnormality	89
	<i>E5</i> ★	OL activation (compressor overload)	90
	<i>E6</i> ★	Compressor lock	91
	<i>E7</i>	DC fan lock	92
	<i>E8</i>	Input over current detection	93
	<i>ER</i>	Four way valve abnormality	94
	<i>F3</i>	Discharge pipe temperature control	96
	<i>F6</i>	High pressure control in cooling	97
	<i>H0</i>	Compressor system sensor abnormality	99
	<i>H6</i>	Position sensor abnormality	100
	<i>H8</i>	DC voltage/current sensor abnormality	101
	<i>H9</i>	Outdoor air thermistor or related abnormality	102
	<i>J3</i>	Discharge pipe temperature thermistor or related abnormality	102
	<i>J6</i>	Heat exchanger temperature thermistor or related abnormality	102
	<i>L3</i>	Electrical box temperature rise	104
	<i>L4</i>	Radiation fin temperature rise	106
	<i>L5</i>	Output over current detection	108
<i>P4</i>	Heat radiation fin thermistor or related abnormality	102	

★: Displayed only when system-down occurs.

4.2 Indoor Unit PCB Abnormality

Remote
Controller
Display

A1

Method of
Malfunction
Detection

Evaluation of zero-cross detection of power supply by indoor unit.

Malfunction
Decision
Conditions

When there is no zero-cross detection in approximately 10 continuous seconds.

Supposed
Causes

- Faulty indoor unit PCB
- Faulty connector connection

Troubleshooting

 **Caution** Be sure to turn off power switch before connect or disconnect connector, or parts damage may be occurred.

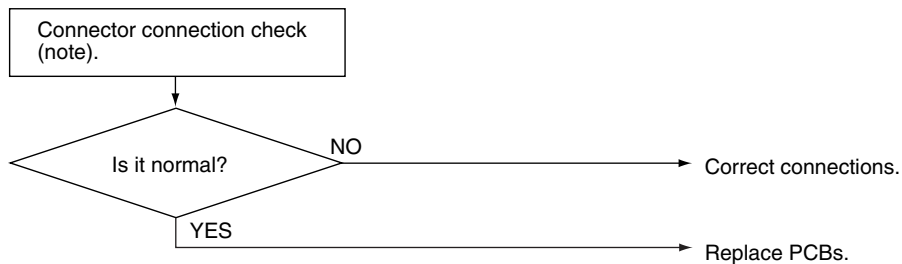

(R1400)

 **Note:** Connector Nos. vary depending on models.

Model Type	Connector No.
Floor/Ceiling Suspended Dual Type	S36~S37

4.3 Freeze-up Protection Control or High Pressure Control

Remote
Controller
Display

AS

Method of
Malfunction
Detection

- High pressure control (heat pump model only)
During heating operations, the temperature detected by the indoor heat exchanger thermistor is used for the high pressure control (stop, outdoor fan stop, etc.)
- Freeze-up protection control (operation halt) is activated during cooling operation according to the temperature detected by the indoor unit heat exchanger thermistor.

Malfunction
Decision
Conditions

- High pressure control
During heating operations, the temperature detected by the indoor heat exchanger thermistor is above 65°C
- Freeze-up protection
When the indoor unit heat exchanger temperature is below 0°C during cooling operation.

Supposed
Causes

- Operation halt due to clogged air filter of the indoor unit.
- Operation halt due to dust accumulation on the indoor unit heat exchanger.
- Operation halt due to short-circuit.
- Detection error due to faulty indoor unit heat exchanger thermistor.
- Detection error due to faulty indoor unit PCB.

Troubleshooting



Check No.06
Refer to P.115



Caution

Be sure to turn off power switch before connect or disconnect connector, or parts damage may be occurred.

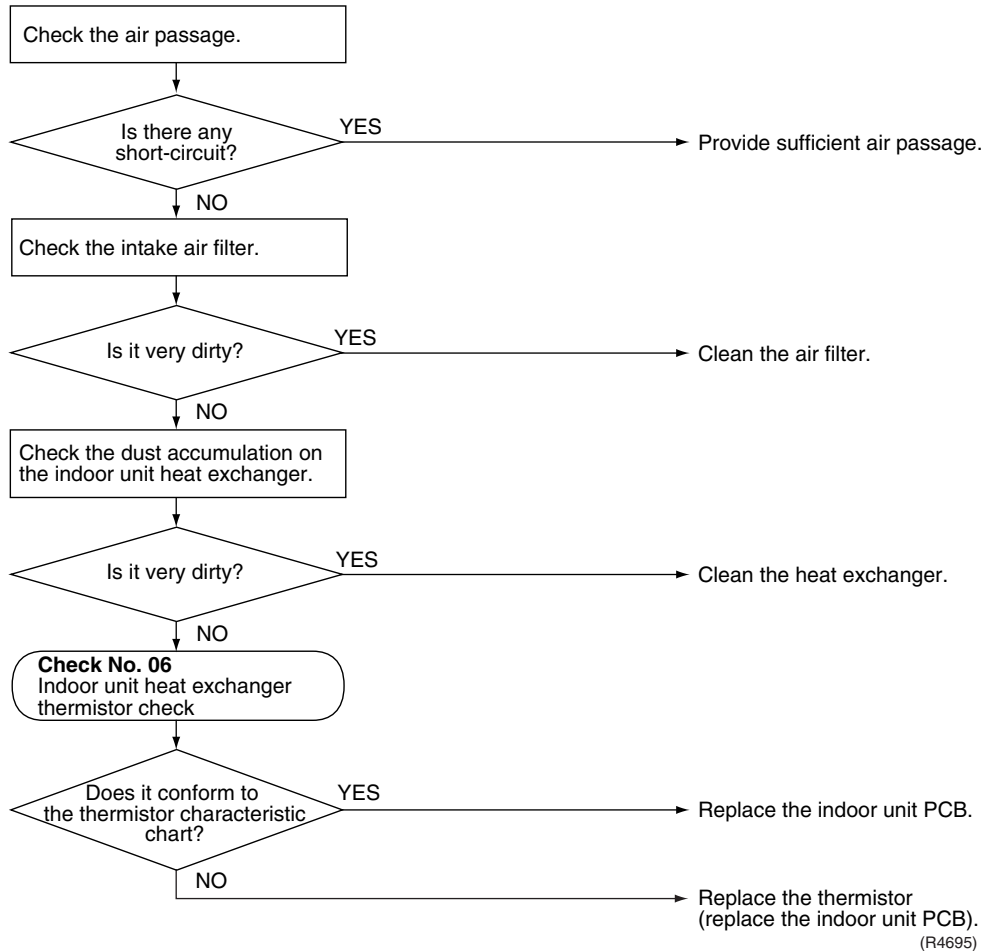

4.4 Fan Motor (AC Motor) or Related Abnormality

Remote
Controller
Display

AB

Method of
Malfunction
Detection

The rotation speed detected by the Hall IC during fan motor operation is used to determine abnormal fan motor operation.

Malfunction
Decision
Conditions

When the detected rotation speed is less than 50% of the HH tap under maximum fan motor rotation demand.

Supposed
Causes

- Operation halt due to short circuit inside the fan motor winding.
- Operation halt due to breaking of wire inside the fan motor.
- Operation halt due to breaking of the fan motor lead wires.
- Operation halt due to faulty capacitor of the fan motor.
- Detection error due to faulty indoor unit PCB.

Troubleshooting



Check No.16
Refer to P.119



Caution

Be sure to turn off power switch before connect or disconnect connector, or parts damage may be occurred.

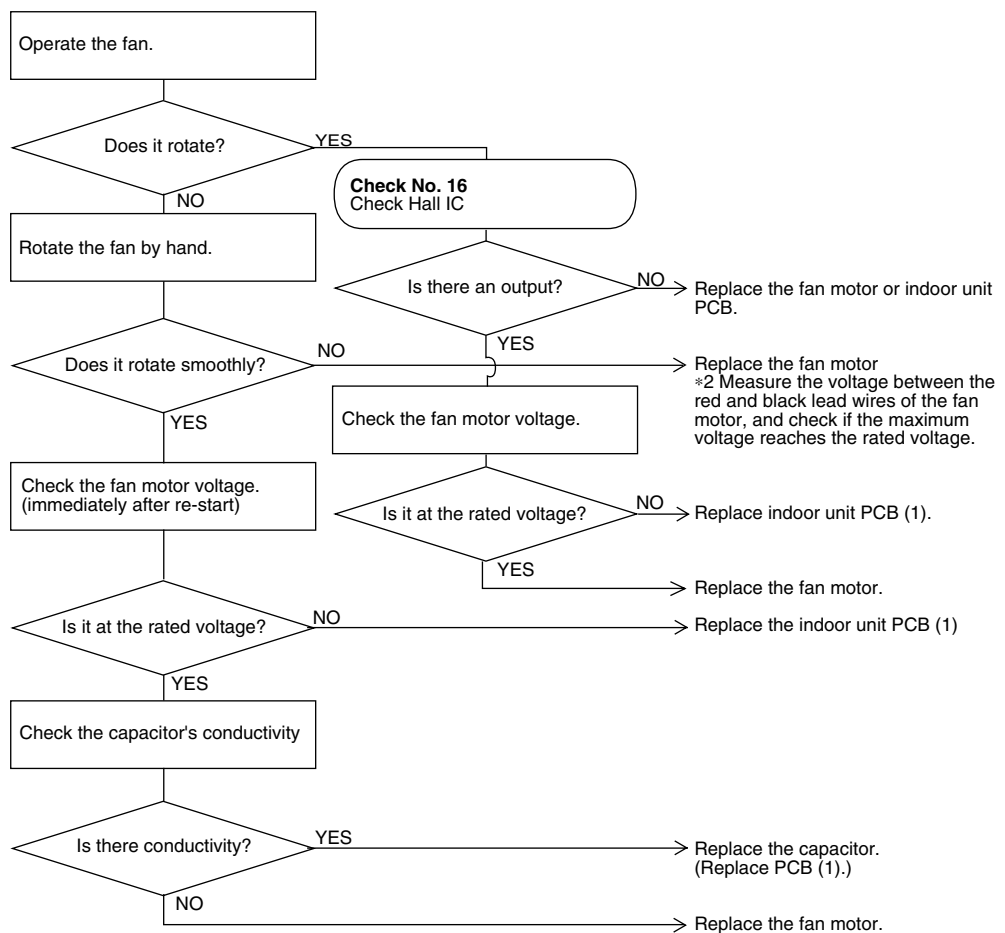

(R1946)

4.5 Thermistor or Related Abnormality (Indoor Unit)

Remote
Controller
Display

Ⓛ4, Ⓛ9

Method of
Malfunction
Detection

The temperatures detected by the thermistors are used to determine thermistor errors.

Malfunction
Decision
Conditions

When the thermistor input is more than 4.96 V or less than 0.04 V during compressor operation*.
* (reference)
When above about 212°C (less than 120 ohms) or below about -50°C (more than 1,860 kohms).



Note: The values vary slightly in some models.

Supposed
Causes

- Faulty connector connection
- Faulty thermistor
- Faulty PCB

Troubleshooting



Check No.06
Refer to P.115



Caution

Be sure to turn off power switch before connect or disconnect connector, or parts damage may be occurred.

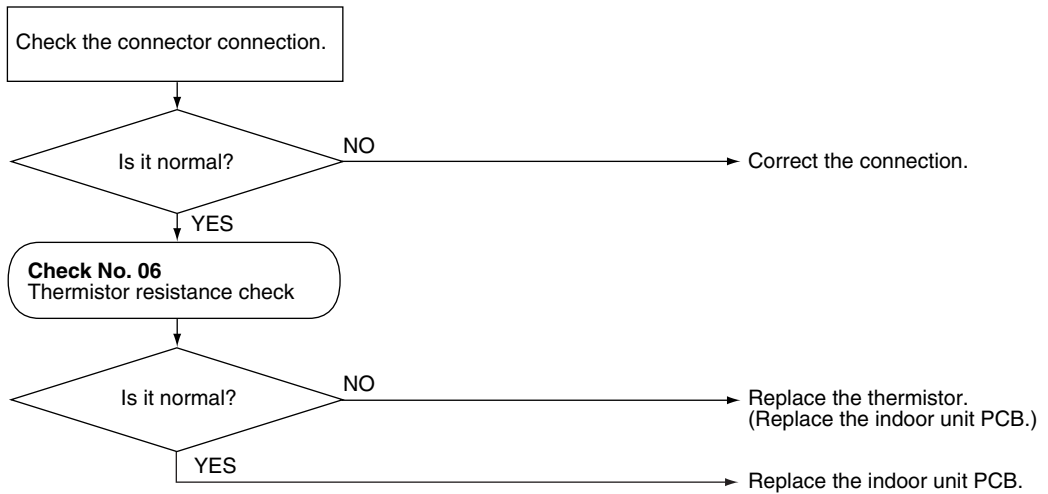

(R4696)

Ⓛ4 : Heat exchanger thermistor
Ⓛ9 : Room temperature thermistor

4.6 Signal Transmission Error (between Indoor and Outdoor Unit)

Remote Controller Display

U4

Method of Malfunction Detection

The data received from the outdoor unit in indoor unit-outdoor unit signal transmission is checked whether it is normal.

Malfunction Decision Conditions

When the data sent from the outdoor unit cannot be received normally, or when the content of the data is abnormal.

Supposed Causes

- Faulty outdoor unit PCB.
- Faulty indoor unit PCB.
- Indoor unit-outdoor unit signal transmission error due to wiring error.
- Indoor unit-outdoor unit signal transmission error due to disturbed power supply waveform.
- Indoor unit-outdoor unit signal transmission error due to breaking of wire in the connection wires between the indoor and outdoor units (wire No. 2).

Troubleshooting

 **Check No.10**
Refer to P.117

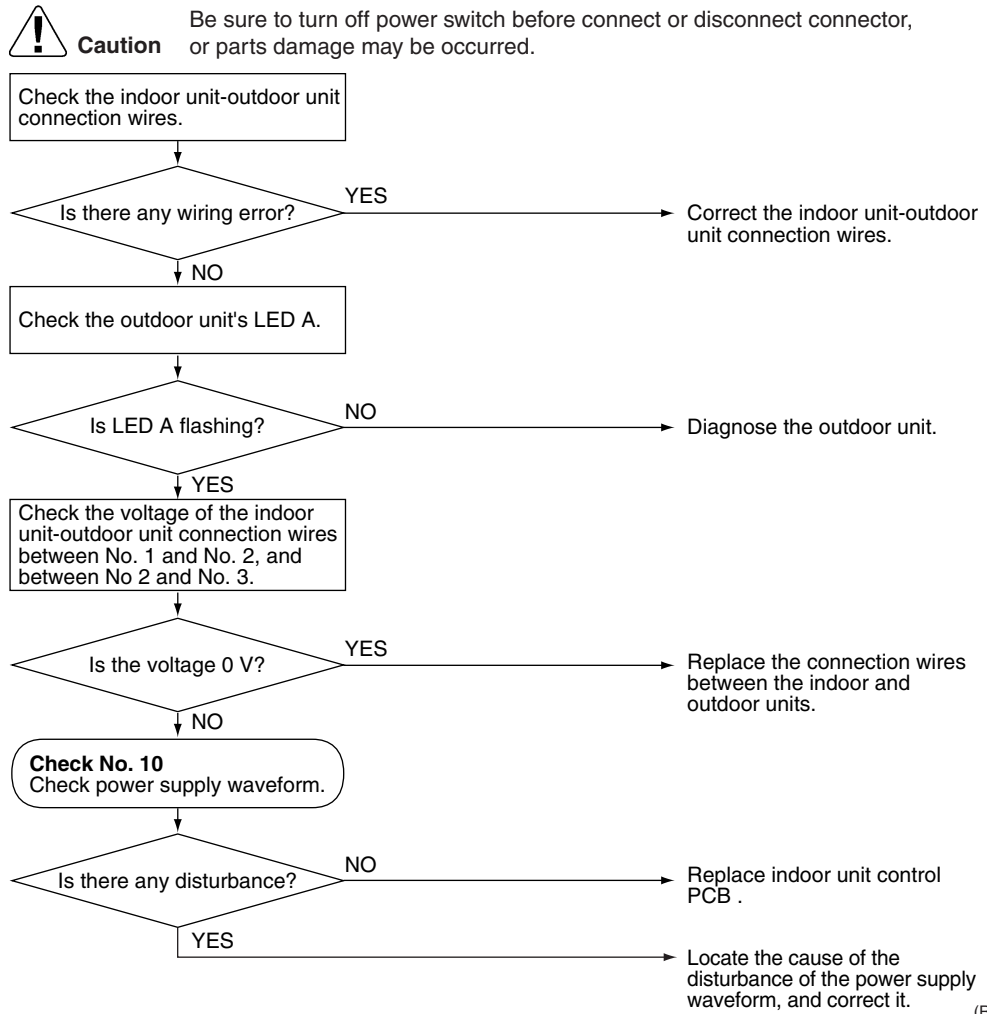

(R2840)

4.7 Unspecified Voltage (between Indoor and Outdoor Units)

Remote
Controller
Display

UR

Method of
Malfunction
Detection

The supply power is detected for its requirements (different from pair type and multi type) by the indoor / outdoor transmission signal.

Malfunction
Decision
Conditions

The pair type and multi type are interconnected.

Supposed
Causes

- Wrong models interconnected
- Wrong indoor unit PCB mounted
- Indoor unit PCB defective
- Wrong outdoor unit PCB mounted or defective

Troubleshooting

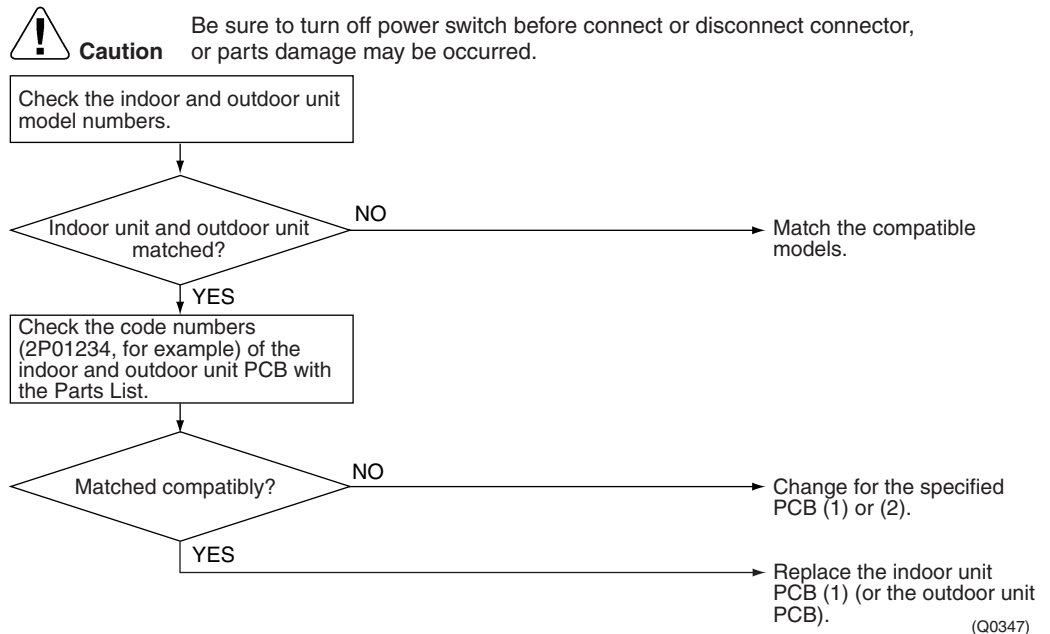

4.8 Outdoor Unit PCB Abnormality

Remote
Controller
Display

E1

Method of
Malfunction
Detection

- The system follows the microprocessor program to make sure it runs normally.
- The system checks to see if the zero-cross signal comes in properly.

Malfunction
Decision
Conditions

- The microprocessor program runs out of control.
- The zero-cross signal is not detected.

Supposed
Causes

- The microcomputer is out of control due to external factors.
 - ◆ Noise
 - ◆ Momentary voltage drop
 - ◆ Momentary power failure, etc.
- Outdoor unit PCB defective
- Broken harness between PCBs

Troubleshooting

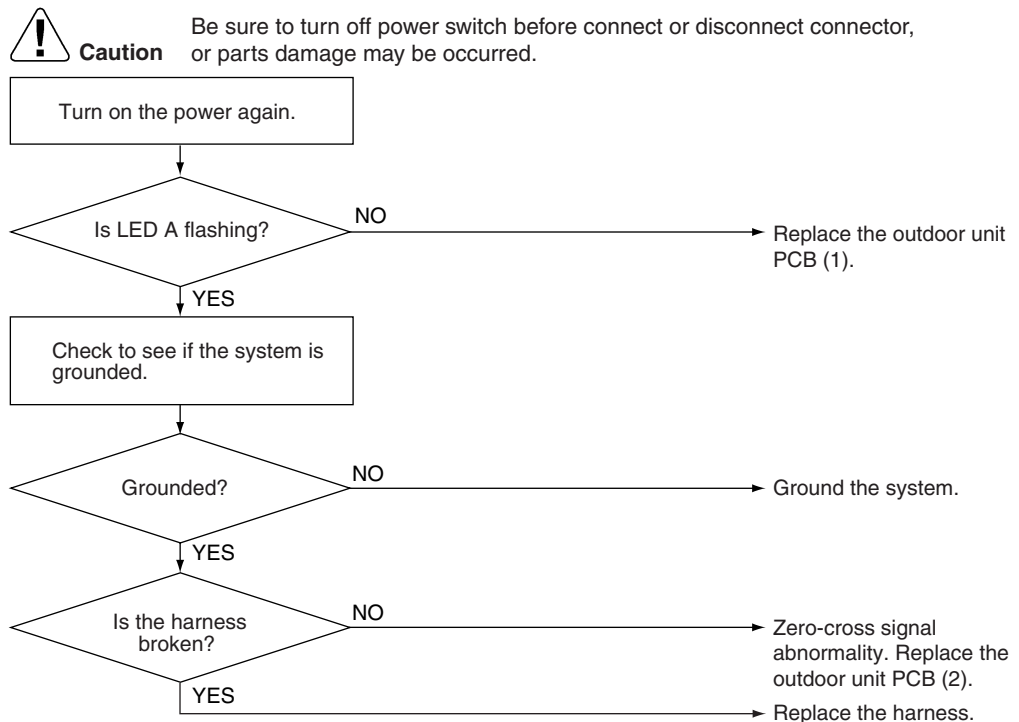

(R4563)

4.9 OL Activation (Compressor Overload)

Remote
Controller
Display

ES

Method of
Malfunction
Detection

A compressor overload is detected through compressor OL.

Malfunction
Decision
Conditions

- If the compressor OL is activated twice, the system will be shut down.
 - The error counter will reset itself if this or any other error does not occur during the following 60-minute compressor running time (total time).
- * The operating temperature condition is not specified.

Supposed
Causes

- Refrigerant shortage
- Four way valve malfunctioning
- Outdoor unit PCB defective
- Water mixed in the local piping
- Electronic expansion valve defective
- Stop valve defective

Troubleshooting

Check No.04
Refer to P.113

Check No.05
Refer to P.114



Check No.06
Refer to P.115

Check No.11
Refer to P.117

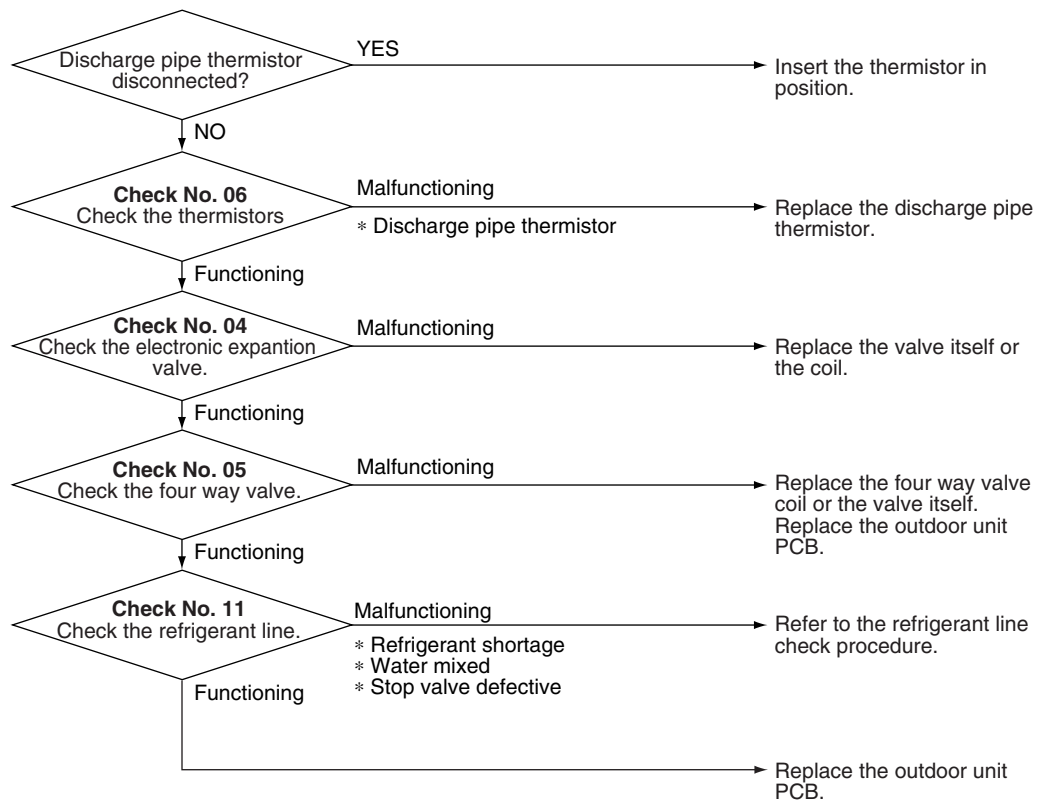

Caution

Be sure to turn off power switch before connect or disconnect connector, or parts damage may be occurred.



(R4697)

4.10 Compressor Lock

Remote
Controller
Display

EG

Method of
Malfunction
Detection

A compressor lock is detected by checking the compressor running condition through the position detection circuit.

Malfunction
Decision
Conditions

- The system judges the compressor lock, and stops due to over current.
- The system judges the compressor lock, and cannot operation with position detection within 15 seconds after start up.
- The system will be shut down if the error occurs 16 times.
- Clearing condition: Continuous run for about 10 minutes (normal)

Supposed
Causes

- Compressor locked
- Compressor harness disconnected

Troubleshooting

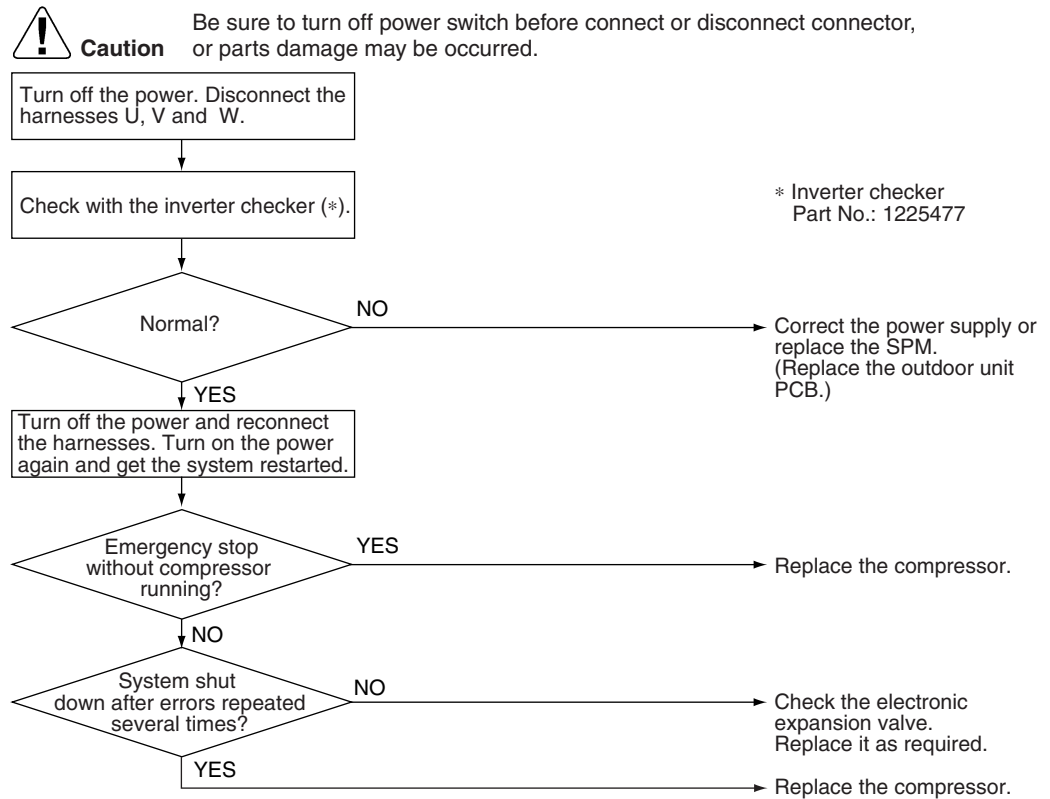

(R2842)



Note: If the model doesn't have SPM, replace the outdoor unit PCB.

4.11 DC Fan Lock

Remote
Controller
Display

E7

Method of
Malfunction
Detection

A fan motor or related error is detected by checking the high-voltage fan motor rpm being detected by the Hall IC.

Malfunction
Decision
Conditions

- The fan does not start in 30 seconds even when the fan motor is running.
- The system will be shut down if the error occurs 16 times.
- Clearing condition: Continuous run for about 10 minutes (normal)

Supposed
Causes

- Fan motor breakdown
- Harness or connector disconnected between fan motor and PCB or in poor contact
- Foreign matters stuck in the fan

Troubleshooting



Check No.15
Refer to P.118

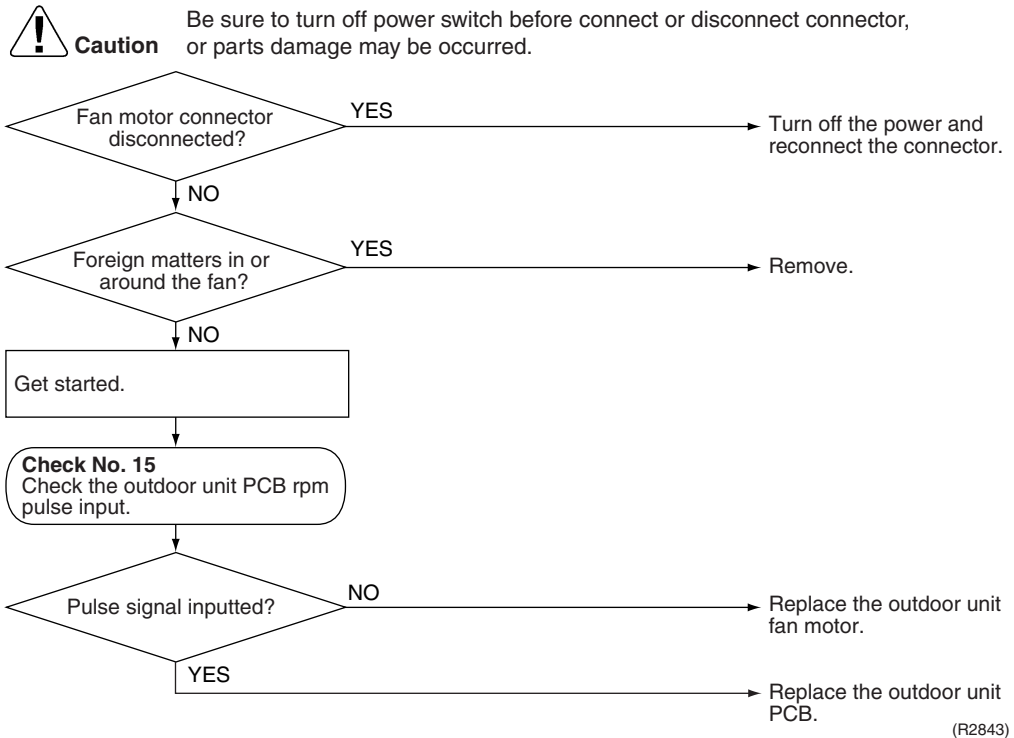

4.12 Input Over Current Detection

Remote
Controller
Display



Method of
Malfunction
Detection

An input over-current is detected by checking the input current value with the compressor running.

Malfunction
Decision
Conditions

- The following current with the compressor running continues for 2.5 seconds.
Cooling / Heating: Above 12A

Supposed
Causes

- Over-current due to compressor failure
- Over-current due to defective power transistor
- Over-current due to defective outdoor unit PCB
- Error detection due to outdoor unit PCB
- Over-current due to short-circuit

Troubleshooting

Check No.07
Refer to P.116

Check No.08
Refer to P.116



Caution Be sure to turn off power switch before connect or disconnect connector, or parts damage may be occurred.

* An input over-current may result from wrong internal wiring. If the wires have been disconnected and reconnected for part replacement, for example, and the system is interrupted by an input over-current, take the following procedure.

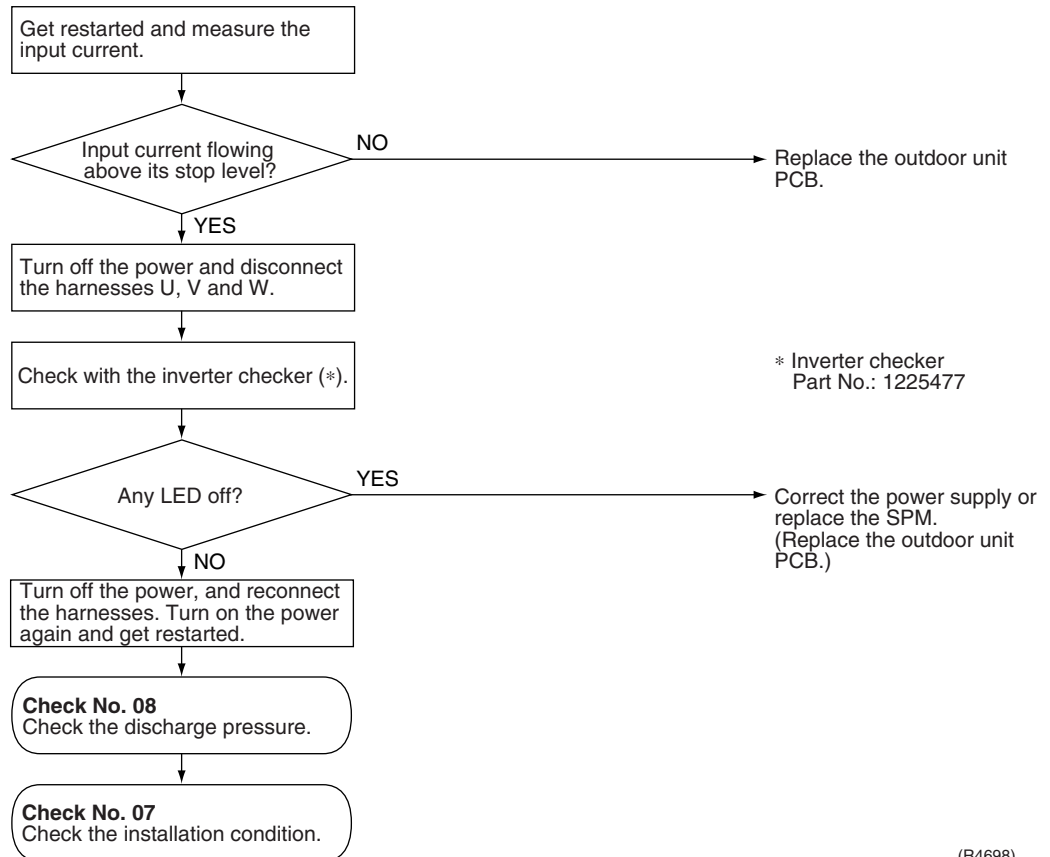

(R4698)



Note: If the model doesn't have SPM, replace the outdoor unit PCB.

4.13 Four Way Valve Abnormality

Remote
Controller
Display

EA

Method of
Malfunction
Detection

The indoor air temperature thermistor, the indoor unit heat exchanger thermistor, the outdoor temperature thermistor and the outdoor unit heat exchanger thermistor are checked to see if they function within their normal ranges in the operating mode.

Malfunction
Decision
Conditions

A following condition continues over 10 minute after operating 5 minutes.

- Cooling / dry operation
(room temp. – indoor heat exchanger temp.) < -5°C
- Heating
(indoor unit heat exchanger temp. – room temp.) < -5°C

Supposed
Causes

- Connector in poor contact
- Thermistor defective
- Outdoor unit PCB defective
- Four way valve coil or harness defective
- Four way valve defective
- Foreign substance mixed in refrigerant
- Insufficient gas

Troubleshooting

 **Check No.05**
Refer to P.114

 **Check No.06**
Refer to P.115

 **Check No.11**
Refer to P.117



Caution Be sure to turn off power switch before connect or disconnect connector, or parts damage may be occurred.

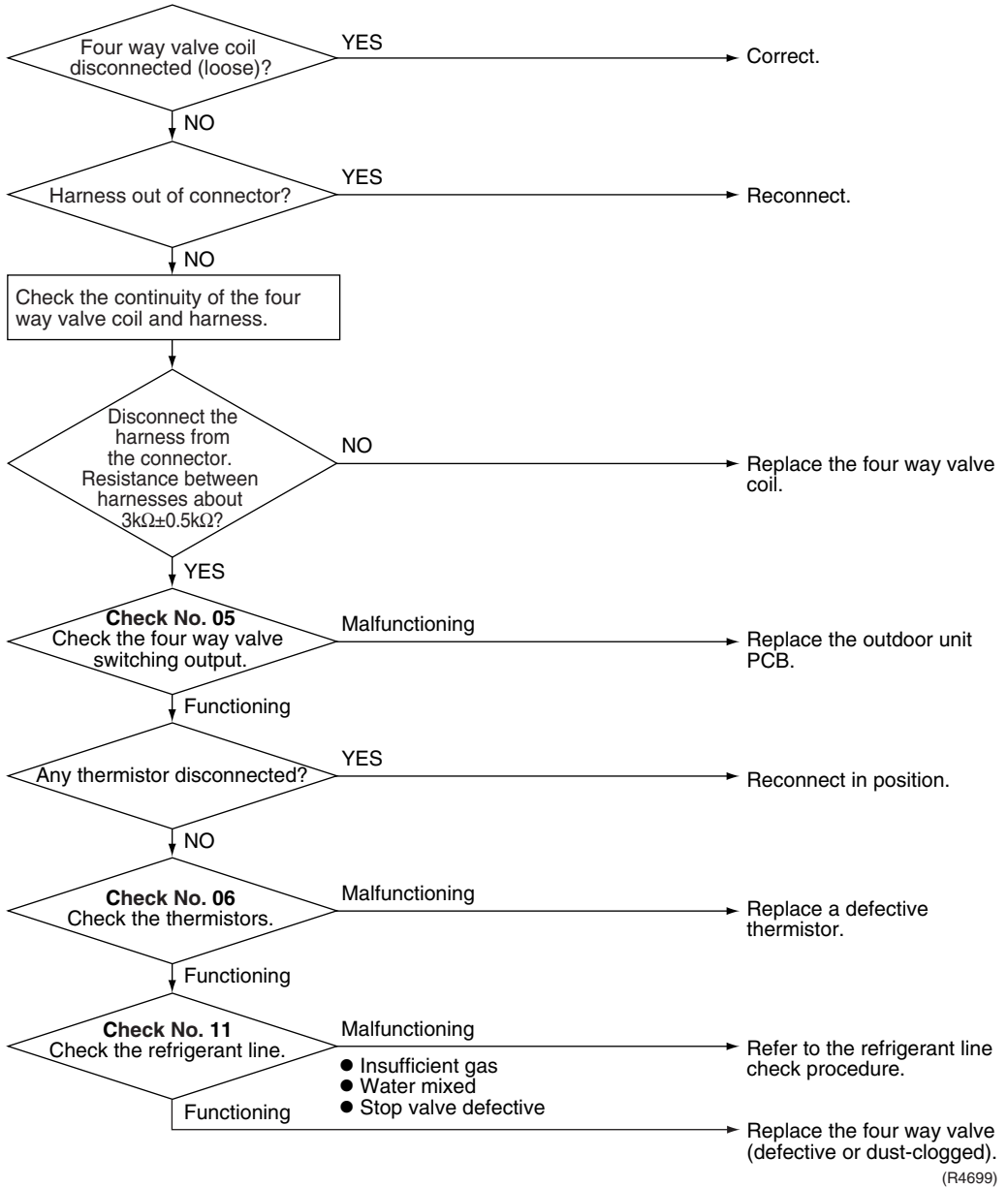

4.14 Discharge Pipe Temperature Control

Remote
Controller
Display



Method of
Malfunction
Detection

The discharge pipe temperature control (stop, frequency drooping, etc.) is checked with the temperature being detected by the discharge pipe thermistor.

Malfunction
Decision
Conditions

- If a stop takes place 4 times successively due to abnormal discharge pipe temperature, the system will be shut down.
- If the temperature being detected by the discharge pipe thermistor rises above Δ °C, the compressor will stop. (The error is cleared when the temperature has dropped below B °C.)

Stop temperatures	Δ	B
(1) above 45Hz (rising), above 40Hz (dropping)	110	97
(2) 30~45Hz (rising), 25~40Hz (dropping)	105	92
(3) below 30Hz (rising), below 25Hz (dropping)	99	86

- The error counter will reset itself if this or any other error does not occur during the following 60-minute compressor running time (total time).

Supposed
Causes

- Refrigerant shortage
- Four way valve malfunctioning
- Discharge pipe thermistor defective (heat exchanger or outdoor air temperature thermistor defective)
- Outdoor unit PCB defective
- Water mixed in the local piping
- Electronic expansion valve defective
- Stop valve defective

Troubleshooting

- Check No.04**
Refer to P.113
- Check No.06**
Refer to P.115
- Check No.11**
Refer to P.117

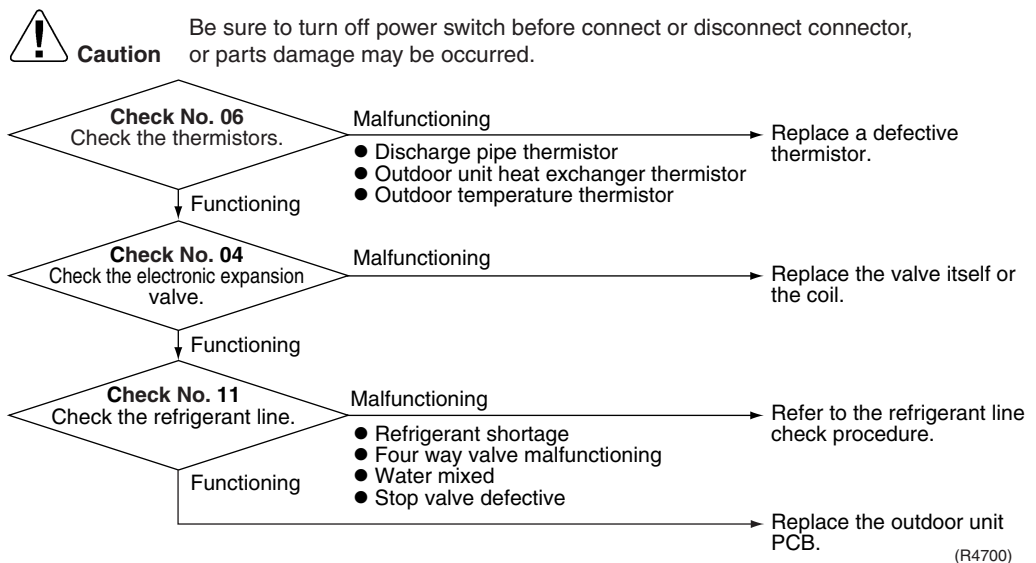

4.15 High Pressure Control in Cooling

Remote
Controller
Display

FB

Method of
Malfunction
Detection

High-pressure control (stop, frequency drop, etc.) is activated in the cooling mode if the temperature being sensed by the heat exchanger thermistor exceeds the limit.

Malfunction
Decision
Conditions

Activated when the temperature being sensed by the heat exchanger thermistor rises above 65°C. (The error is cleared when the temperature drops below 54°C.)

Supposed
Causes

- The installation space is not large enough.
- Faulty outdoor unit fan
- Faulty electronic expansion valve
- Faulty defrost thermistor
- Faulty outdoor unit PCB
- Faulty stop valve
- Dirty heat exchanger

Troubleshooting

Check No.04
 Refer to P.113

Check No.06
 Refer to P.115

Check No.07
 Refer to P.116

Check No.09
 Refer to P.117

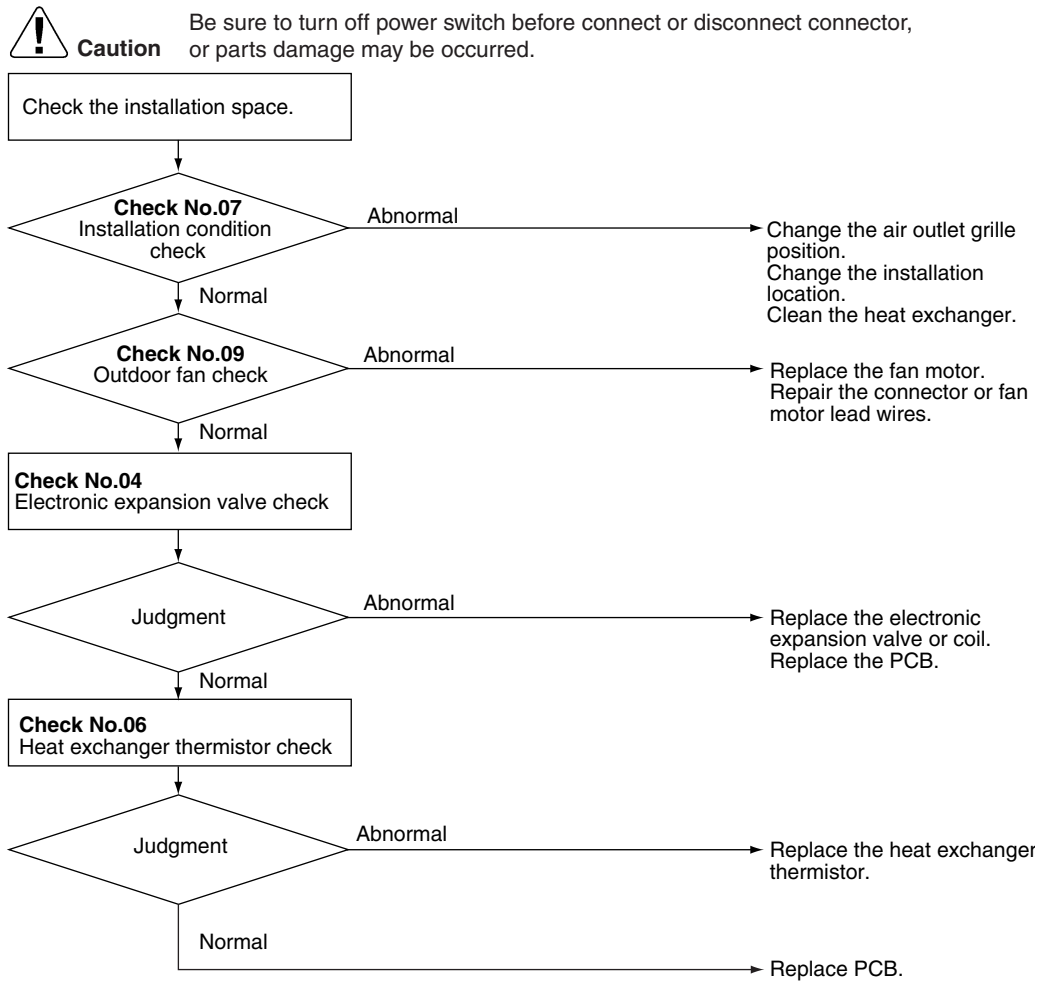

(R4701)

4.16 Compressor System Sensor Abnormality

Remote
Controller
Display

HO

Method of
Malfunction
Detection

- The system checks the DC current before the compressor starts.

Malfunction
Decision
Conditions

- If the DC current before compressor start-up is out of the range 0.5-4.5 V (sensor output converted to voltage value) or if the DC voltage before compressor start-up is below 50 V.

Supposed
Causes

- PCB defective
- Broken or poorly connected harness

Troubleshooting

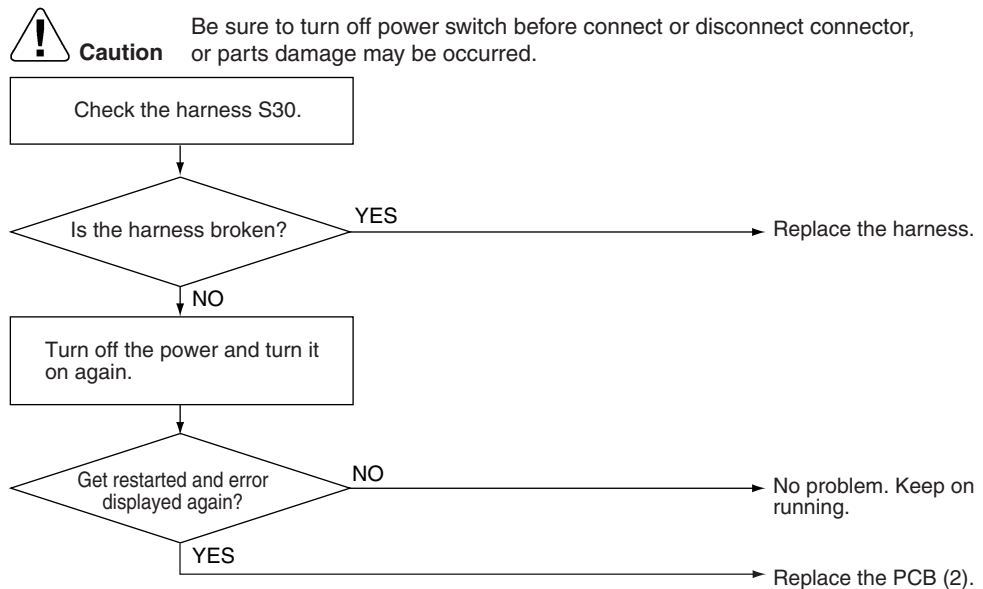

(R4564)

4.17 Position Sensor Abnormality

Remote
Controller
Display

H6

Method of
Malfunction
Detection

A compressor startup failure is detected by checking the compressor running condition through the position detection circuit.

Malfunction
Decision
Conditions

- The compressor fails to start in about 15 seconds after the compressor run command signal is sent.
- Clearing condition: Continuous run for about 10 minutes (normal)
- The system will be shut down if the error occurs 16 times.

Supposed
Causes

- Compressor relay cable disconnected
- Compressor itself defective
- Outdoor unit PCB defective
- Stop valve closed
- Input voltage out of specification

Troubleshooting



Check No.13
Refer to P.118

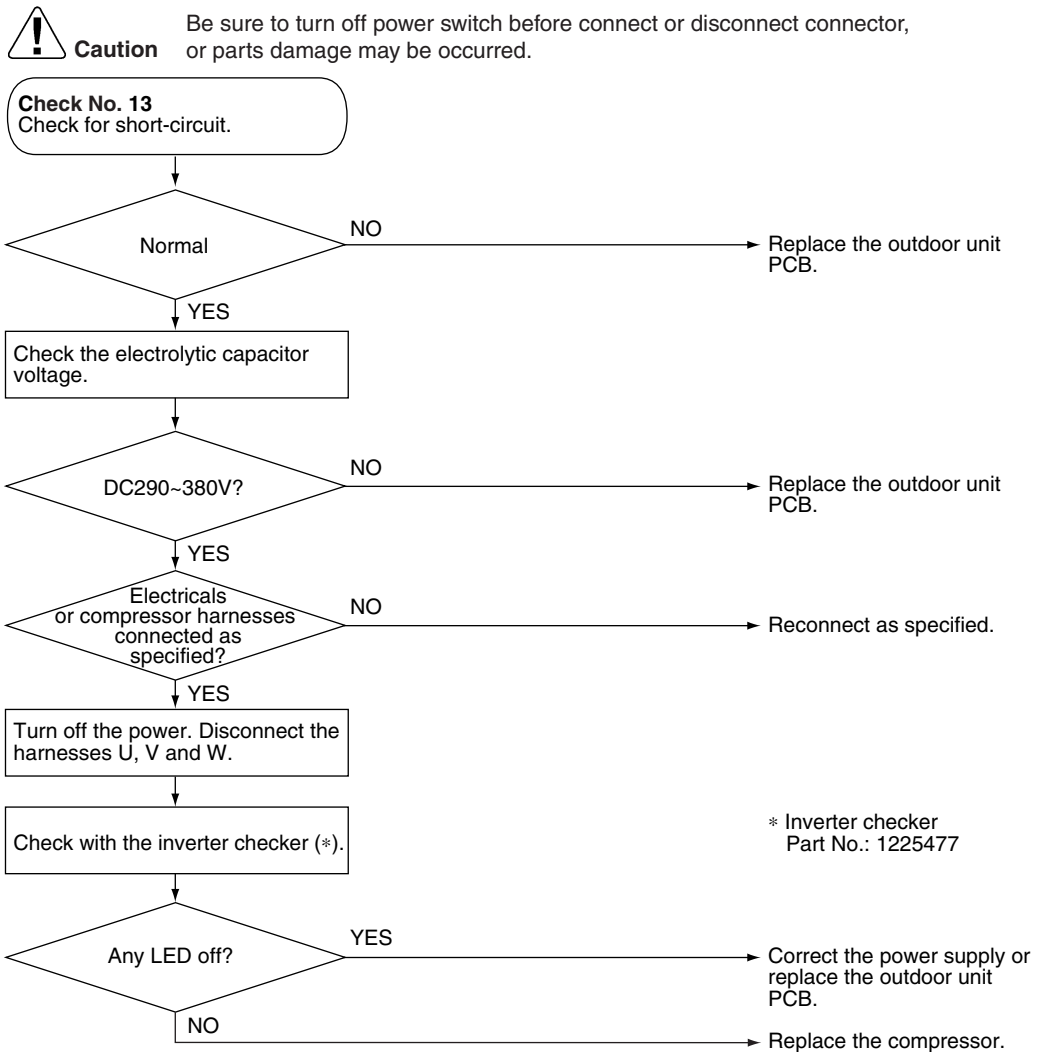

(R3041)

4.18 DC Voltage / Current Sensor Abnormality

Remote
Controller
Display

H8

Method of
Malfunction
Detection

Detecting abnormality of the DC sensor by the running frequency of compressor and by the input current multiplied DC voltage and current.

Malfunction
Decision
Conditions

The compressor running frequency is below 52 Hz.
(The input current is also below 0.5 A.)

- If this error repeats 4 times, the system will be shut down.
- The error counter will reset itself if this or any other error does not occur during the following 60-minute compressor running time (total time).

Supposed
Causes

- Outdoor unit PCB defective

Troubleshooting



Caution

Be sure to turn off power switch before connect or disconnect connector, or parts damage may be occurred.

Replace the outdoor unit PCB.

4.19 Thermistor or Related Abnormality (Outdoor Unit)

Remote
Controller
Display

P4, J3, J6, H9

Method of
Malfunction
Detection

This type of error is detected by checking the thermistor input voltage to the microcomputer.
[A thermistor error is detected by checking the temperature.]

Malfunction
Decision
Conditions

The thermistor input is above 4.96 V or below 0.04 V with the power on.
Error *J3* is judged if the discharge pipe thermistor temperature is smaller than the condenser thermistor temperature.

Supposed
Causes

- Connector in poor contact
- Thermistor defective
- Outdoor unit PCB defective
- Indoor unit PCB defective
- Condenser thermistor defective in the case of *J3* error (outdoor unit heat exchanger thermistor in the cooling mode, or indoor unit heat exchanger thermistor in the heating mode)

Troubleshooting



Check No.06
Refer to P.115

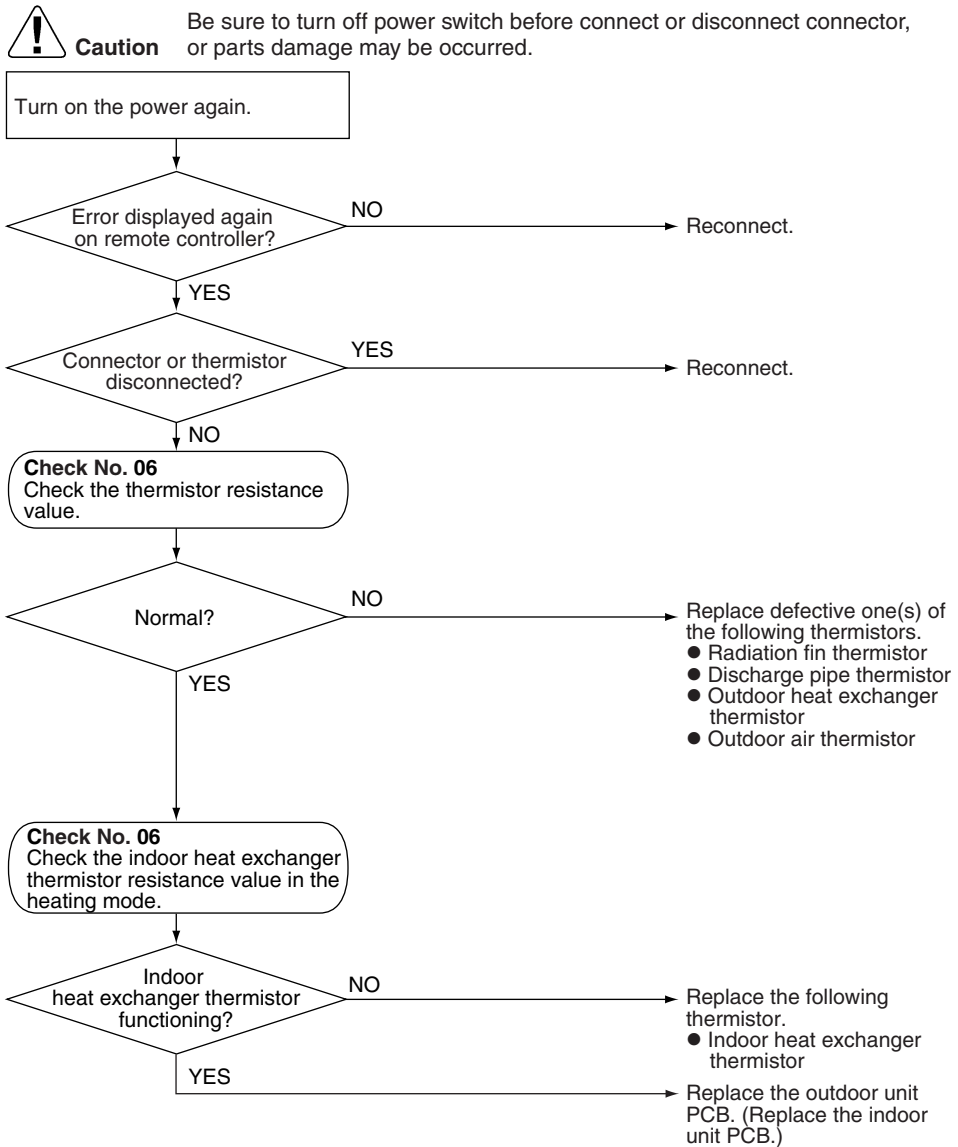

(R4702)

P4 : Radiation fin thermistor
J3 : Discharge pipe thermistor
J5 : Outdoor heat exchanger thermistor
H9 : Outdoor air temperature thermistor

4.20 Electrical Box Temperature Rise

Remote
Controller
Display

L3

Method of
Malfunction
Detection

An electrical box temperature rise is detected by checking the radiation fin thermistor with the compressor off.

Malfunction
Decision
Conditions

With the compressor off, the radiation fin temperature is above 80°C. Reset is made when the temperature drops below 70°C.

Supposed
Causes

- Fin temperature rise due to defective outdoor unit fan
- Fin temperature rise due to short-circuit
- Fin thermistor defective
- Connector in poor contact
- Outdoor unit PCB defective

Troubleshooting

 **Check No.06**
Refer to P.115

 **Check No.07**
Refer to P.116

 **Check No.09**
Refer to P.117

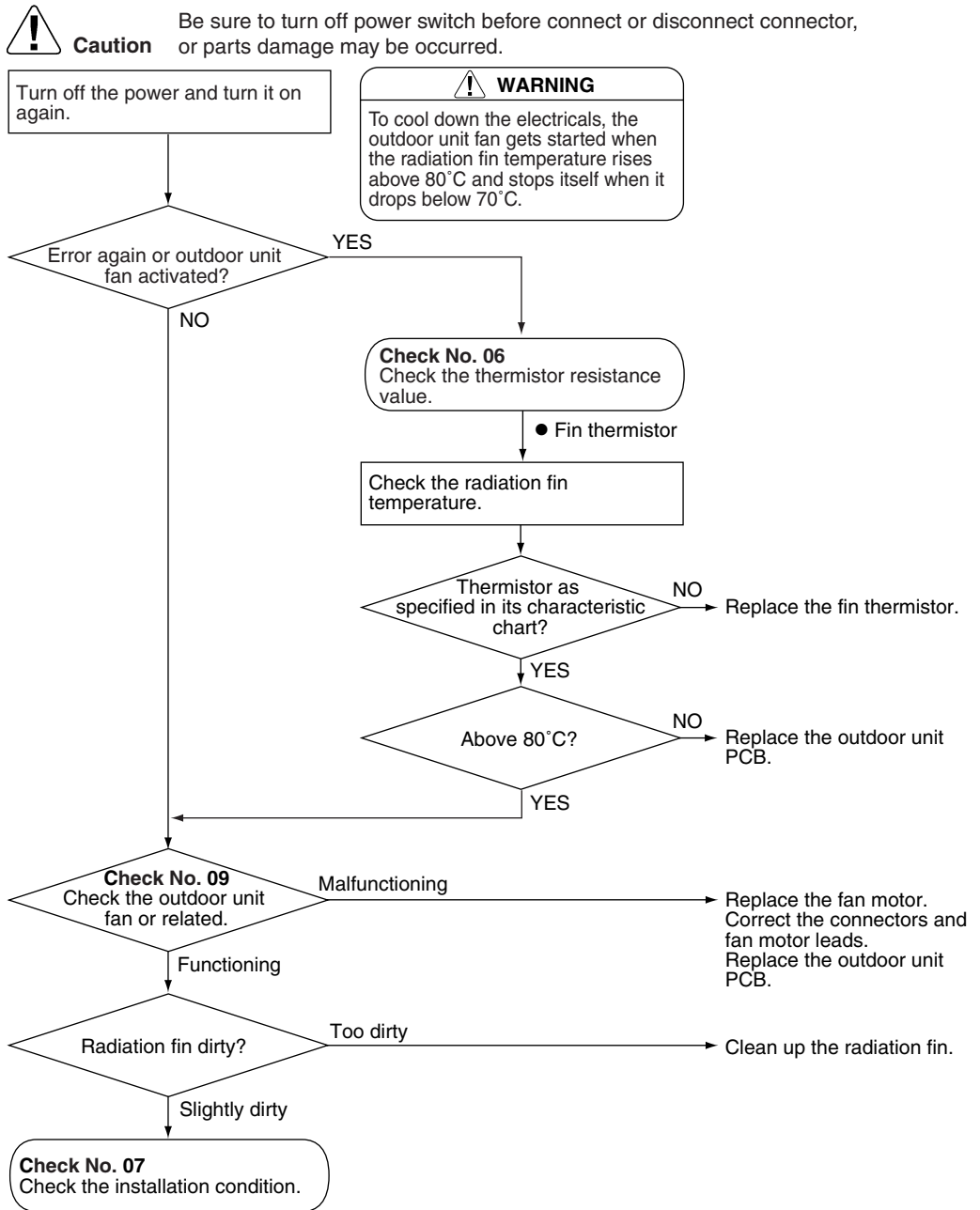

(R4703)

4.21 Radiation Fin Temperature Rise

Remote
Controller
Display

L4

Method of
Malfunction
Detection

A radiation fin temperature rise is detected by checking the radiation fin thermistor with the compressor on.

Malfunction
Decision
Conditions

If the radiation fin temperature with the compressor on is above 90°C.

- If a radiation fin temperature rise takes place 4 times successively, the system will be shut down.
- The error counter will reset itself if this or any other error does not occur during the following 60-minute compressor running time (total time).

Supposed
Causes

- Fin temperature rise due to defective outdoor unit fan
- Fin temperature rise due to short-circuit
- Fin thermistor defective
- Connector in poor contact
- Outdoor unit PCB defective

Troubleshooting

 **Check No.06**
Refer to P.115

 **Check No.07**
Refer to P.116

 **Check No.09**
Refer to P.117

 **Caution** Be sure to turn off power switch before connect or disconnect connector, or parts damage may be occurred.

Turn off the power and turn it on again to get the system started.

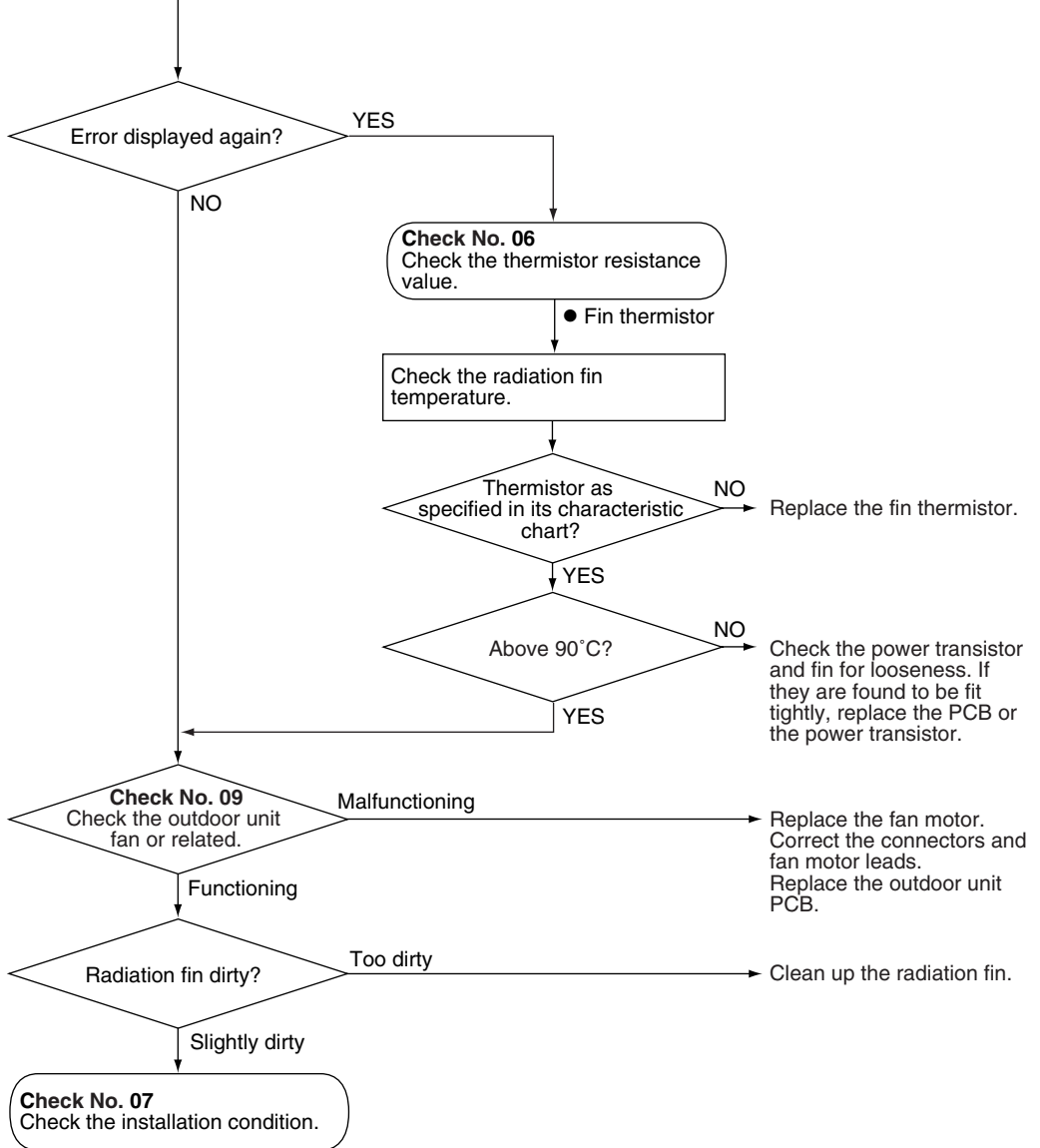

(R4704)

4.22 Output Over Current Detection

Remote
Controller
Display

L5

Method of
Malfunction
Detection

An output over-current is detected by checking the current that flows in the inverter DC section.

Malfunction
Decision
Conditions

- A position signal error occurs while the compressor is running.
- A speed error occurs while the compressor is running.
- An output over-current input is fed from the output over-current detection circuit to the microcomputer.
- The system will be shut down if the error occurs 255 times.
- Clearing condition: Continuous run for about 10 minutes (normal)

Supposed
Causes

- Over-current due to defective power transistor
- Over-current due to wrong internal wiring
- Over-current due to abnormal supply voltage
- Over-current due to defective PCB
- Error detection due to defective PCB
- Over-current due to closed stop valve
- Over-current due to compressor failure
- Over-current due to poor installation condition

Troubleshooting



Check No.07
 Refer to P.116

Check No.08
 Refer to P.116

Check No.13
 Refer to P.118

 **Caution** Be sure to turn off power switch before connect or disconnect connector, or parts damage may be occurred.

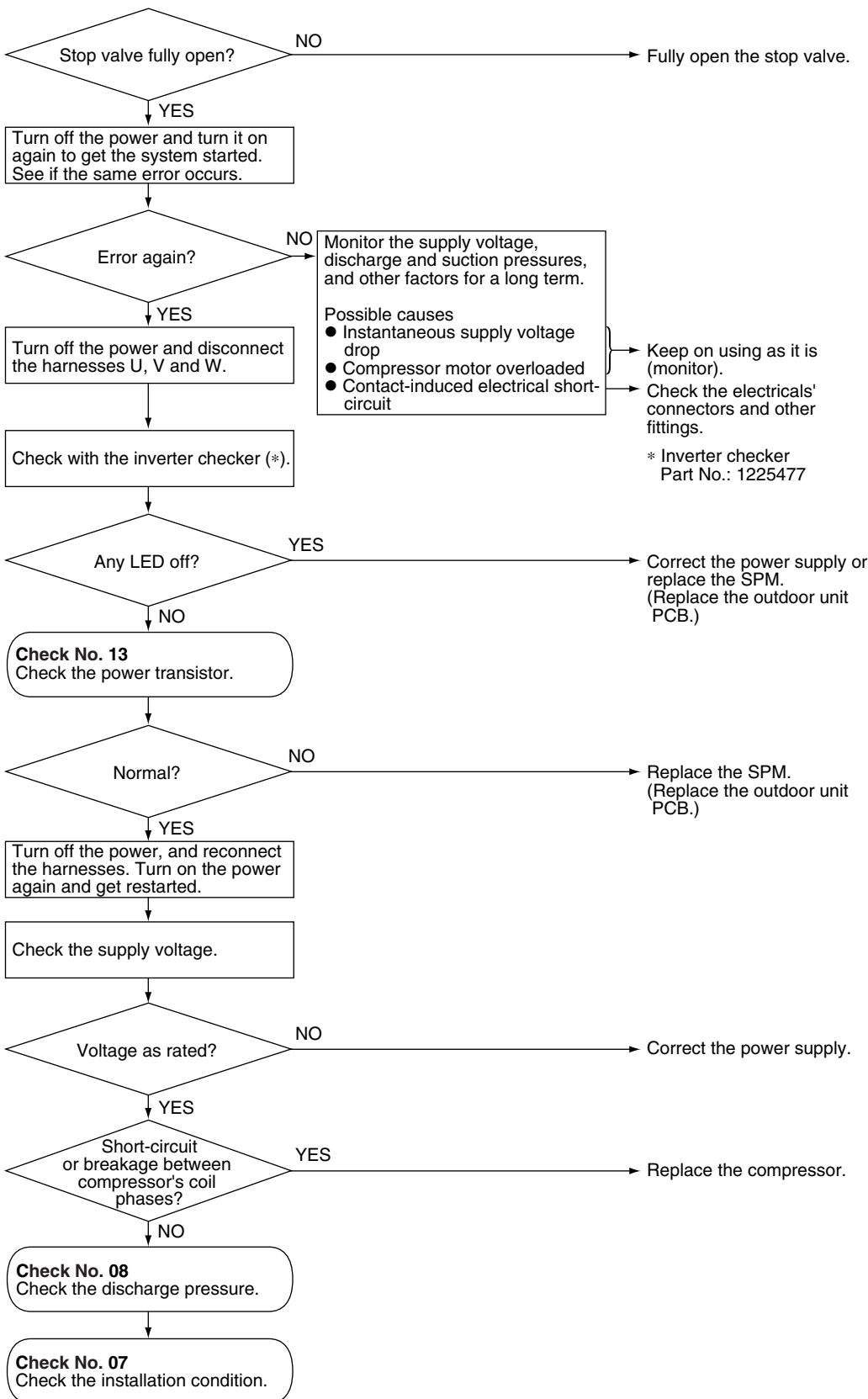
* An output over-current may result from wrong internal wiring. If the wires have been disconnected and reconnected for part replacement, for example, and the system is interrupted by an output over-current, take the following procedure.



* Inverter checker
 Part No.: 1225477

 **Note:** If the model doesn't have SPM, replace the outdoor unit PCB.

(R4705)

4.23 Insufficient Gas

Remote
Controller
Display

U0

Method of
Malfunction
Detection

Gas shortage detection I:

Gas shortage is detected by checking the input current value and the compressor running frequency. If the gas is short, the input current is smaller than the normal value.

Gas shortage detection II:

Gas shortage is detected by checking the discharge temperature and the opening of the electronic expansion valve. If the gas is short, the discharge temperature tends to rise.

Gas shortage detection III:

A gas shortage is detected by checking the difference between inhale and exhale temperature.

Malfunction
Decision
Conditions

Gas shortage detection I:

The following conditions continue for 7 minutes.

- ◆ Input current × input voltage ≤ 640 / 256 × output frequency
- ◆ Output frequency > 55 (Hz)

Gas shortage detection II:

The following conditions continue for 80 seconds.

- ◆ Target opening of the electronic expansion valve ≥ 480 (pulse)
- ◆ Discharge temperature > 255 / 256 × target discharge temperature +30 (°C)

Gas shortage detection III:

When the difference of the temperature is smaller than Δ, it is regarded as insufficient gas.

		Δ
Cooling	room temperature – indoor heat exchanger temperature	4.0°C
	outdoor heat exchanger temperature – outdoor temperature	4.0°C
Heating	indoor heat exchanger temperature – room temperature	3.0°C
	outdoor temperature – outdoor heat exchanger temperature	3.0°C

If a gas shortage error takes place 4 times straight, the system will be shut down. The error counter will reset itself if this or any other error does not occur during the following 60-minute compressor running time (total time).

Supposed
Causes

- Refrigerant shortage (refrigerant leakage)
- Poor compression performance of compressor
- Discharge pipe thermistor disconnected, or indoor unit or outdoor unit heat exchanger thermistor disconnected, room or outdoor air temperature thermistor disconnected
- Stop valve closed
- Electronic expansion valve defective

Troubleshooting



Check No.04
Refer to P.113



Check No.06
Refer to P.115



Caution Be sure to turn off power switch before connect or disconnect connector, or parts damage may be occurred.

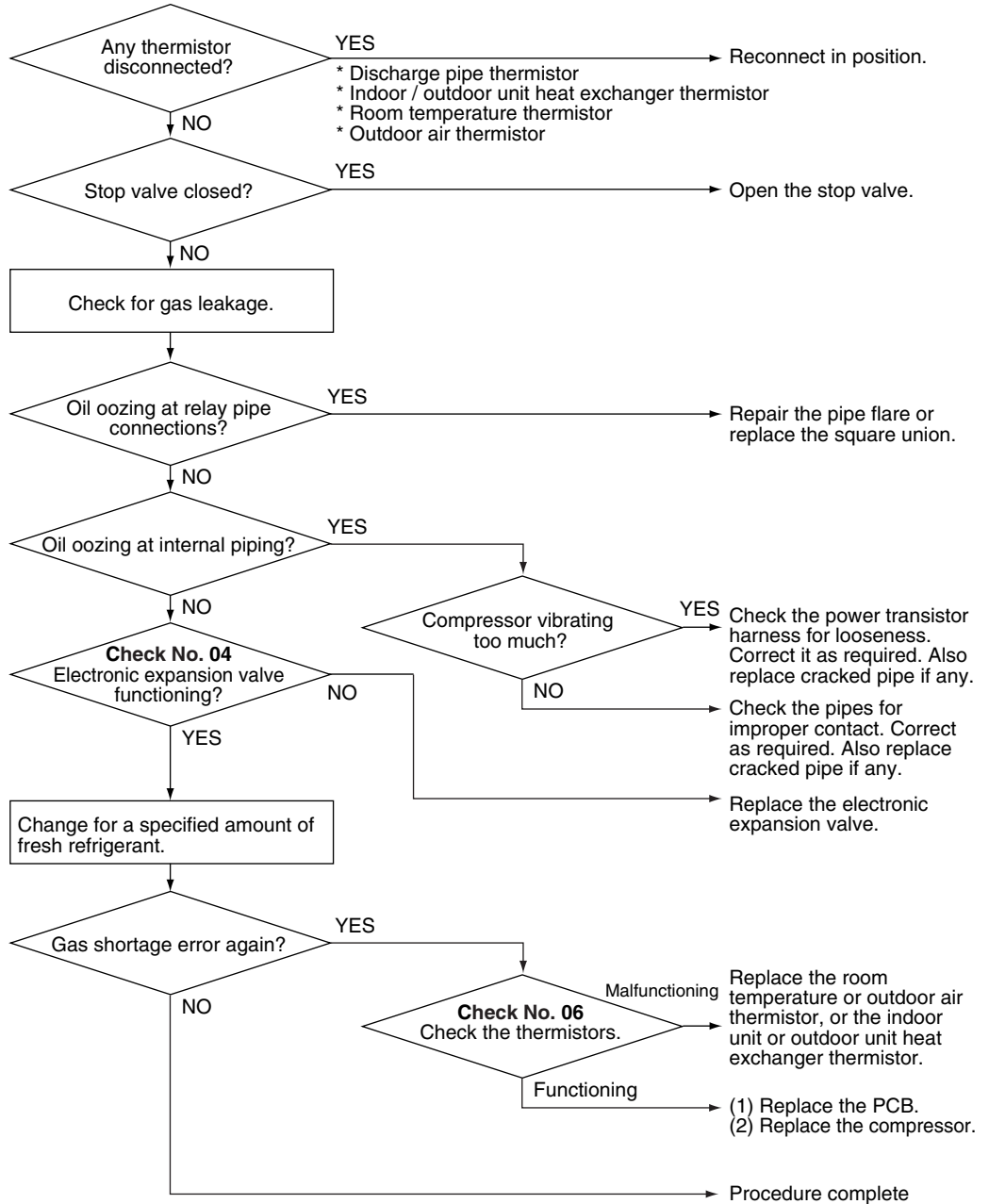

(R4706)

4.24 Over-voltage Detection

Remote Controller Display	<i>U2</i>
Method of Malfunction Detection	An abnormal voltage rise is detected by checking the specified over-voltage detection circuit.
Malfunction Decision Conditions	<ul style="list-style-type: none"> ■ An over-voltage signal is fed from the over-voltage detection circuit to the microcomputer (The voltage is over 400V). ■ The system will be shut down if the error occurs 255 times. ■ Clearing condition: Continuous run for about 10 minutes (normal)
Supposed Causes	<ul style="list-style-type: none"> ■ Supply voltage not as specified ■ Over-voltage detection circuit defective ■ PAM control part(s) defective

Troubleshooting

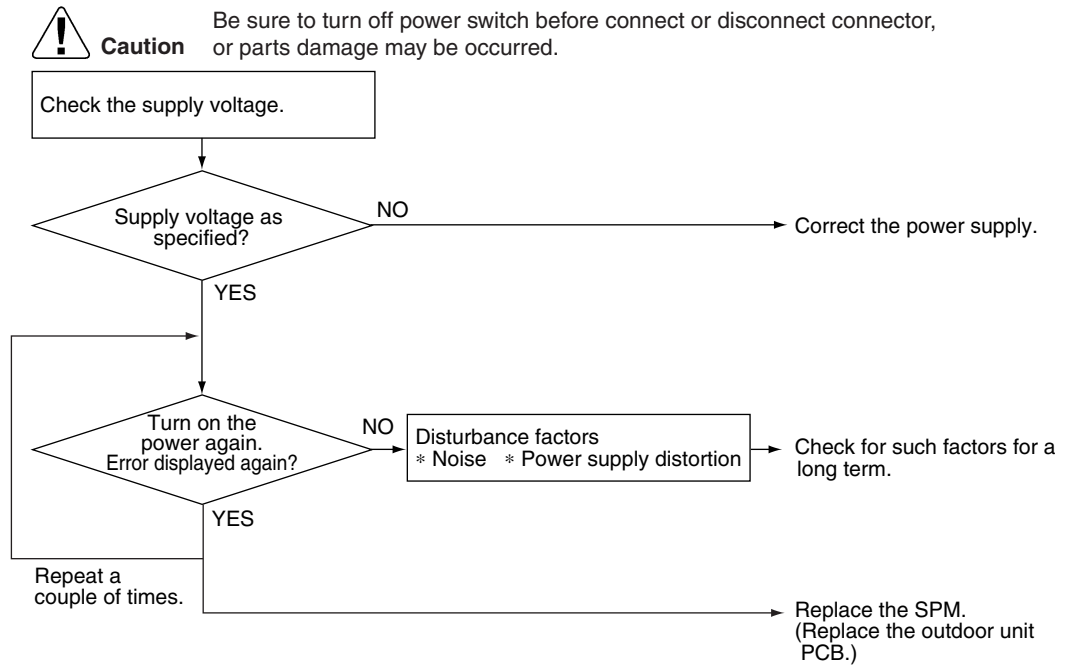

(R2957)



Note: If the model doesn't have SPM, replace the outdoor unit PCB.

5. Check

5.1 How to Check

5.1.1 Electronic Expansion Valve Check

Check No.04

Conduct the followings to check the electronic expansion valve (EV).

1. Check to see if the EV connector is correctly inserted in the PCB. Compare the EV unit and the connector number.
2. Turn the power off and back on again, and check to see if all the EVs generate latching sound.
3. If any of the EVs does not generate latching noise in the above step 2, disconnect that connector and check the conductivity using a tester.
Check the conductivity between pins 1, 3 and 6, and between pins 2, 4 and 5. If there is no conductivity between the pins, the EV coil is faulty.

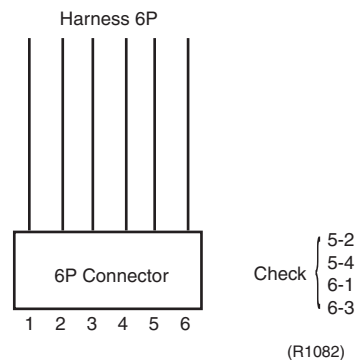

4. If no EV generates latching sound in the above step 2, the outdoor unit PCB is faulty.
5. If the conductivity is confirmed in the above step 2, mount a good coil (which generated latching sound) in the EV unit that did not generate latching sound, and check to see if that EV generates latching sound.
*If latching sound is generated, the outdoor unit PCB is faulty.
*If latching sound is not generated, the EV unit is faulty.



Note: Please note that the latching sound varies depending on the valve type.

5.1.2 Four Way Valve Performance Check

Check No.05

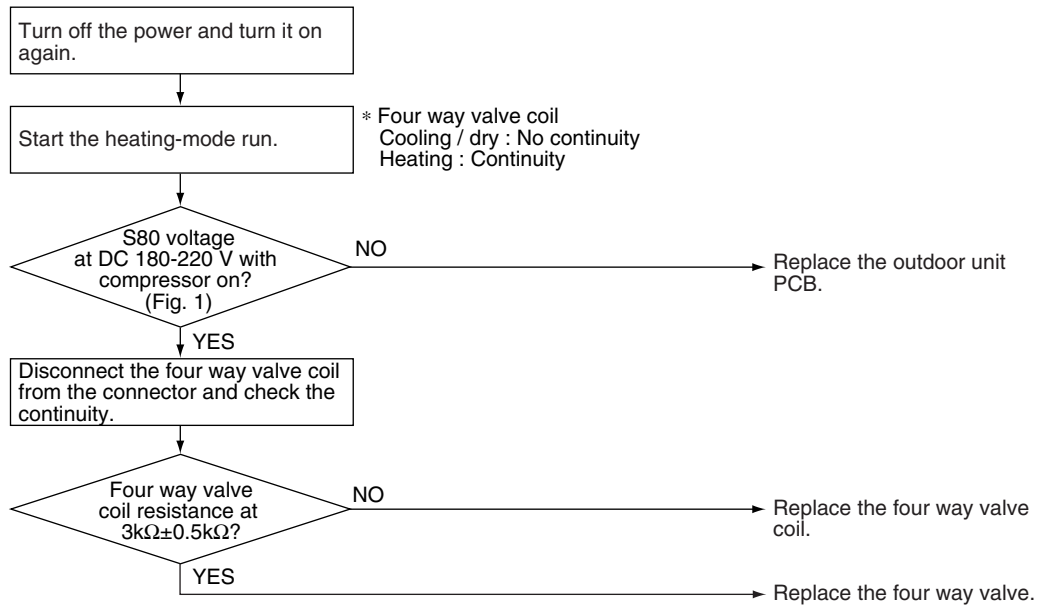

(Fig. 1)

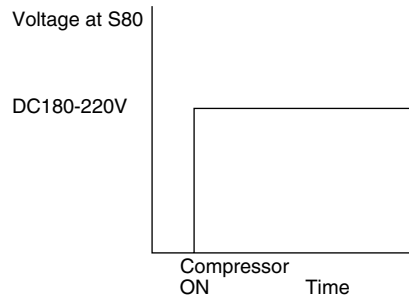

(R3047)

5.1.3 Thermistor Resistance Check

Check No.06

Remove the connectors of the thermistors on the PCB, and measure the resistance of each thermistor using tester.

The relationship between normal temperature and resistance is shown in the graph and the table below.

Temperature (°C)	Thermistor R25°C=20kΩ B=3950
-20	211.0 (kΩ)
-15	150
-10	116.5
-5	88
0	67.2
5	51.9
10	40
15	31.8
20	25
25	20
30	16
35	13
40	10.6
45	8.7
50	7.2

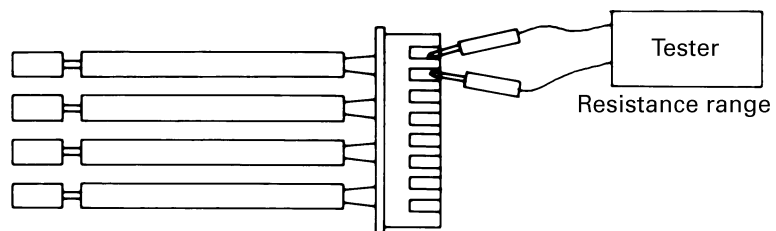

(R25 = 20k Ω 、 B = 3950)

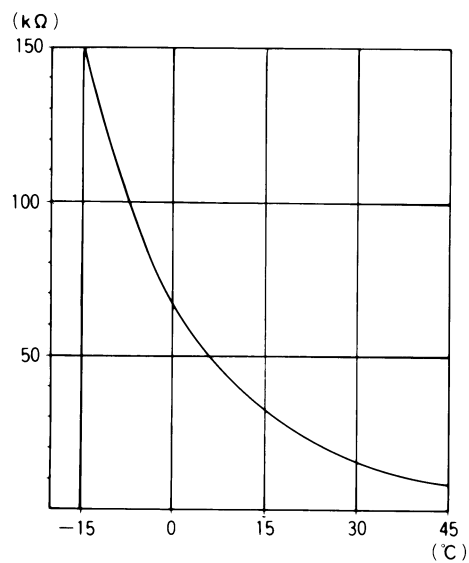

(R1437)

5.1.4 Installation Condition Check

Check No.07

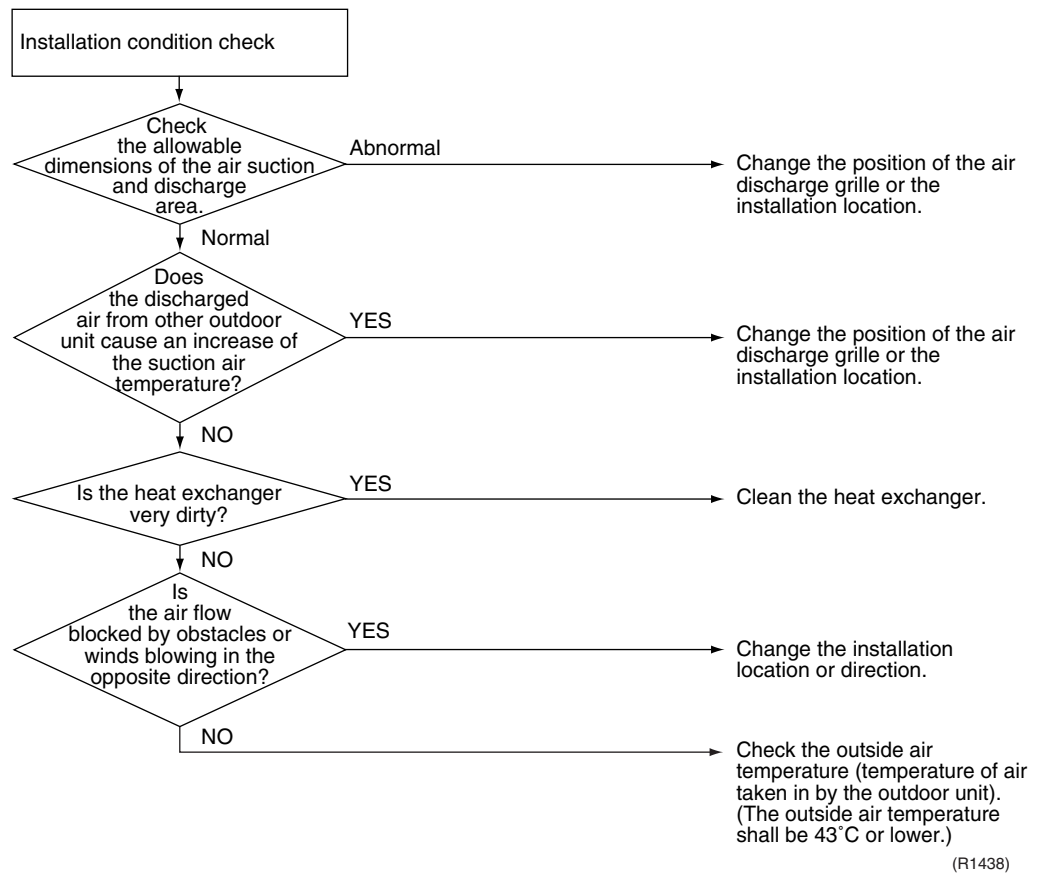

(R1438)

5.1.5 Discharge Pressure Check

Check No.08

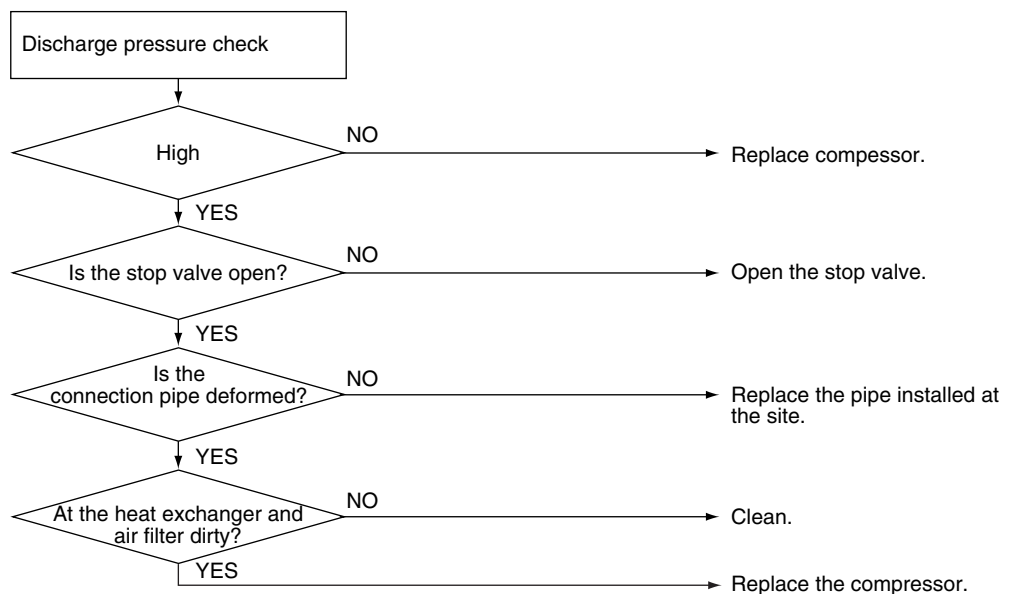

(R1443)

5.1.6 Outdoor Unit Fan System Check

Check No.09

DC motor

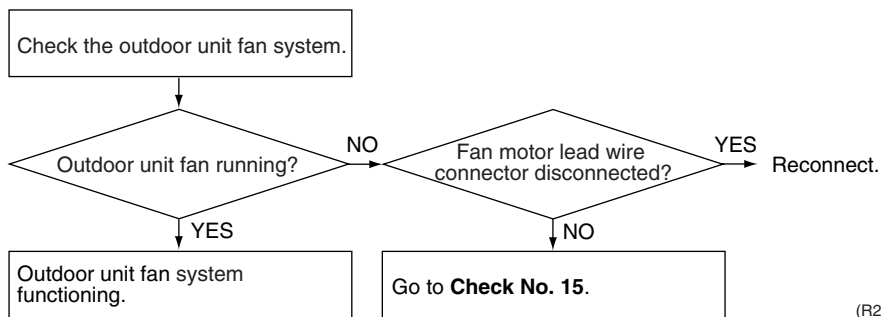

(R2857)

5.1.7 Power Supply Waveforms Check

Check No.10

Measure the power supply waveform between pins 1 and 3 on the terminal board, and check the waveform disturbance.

- Check to see if the power supply waveform is a sine wave (Fig.1).
- Check to see if there is waveform disturbance near the zero cross (sections circled in Fig.2)

[Fig.1]

[Fig.2]

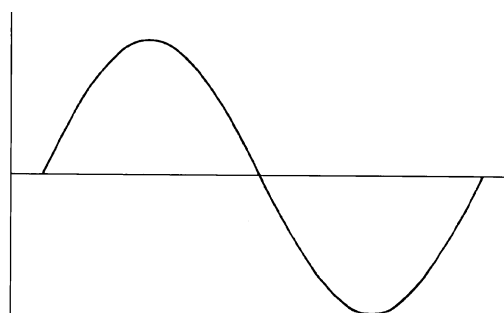

(R1736)

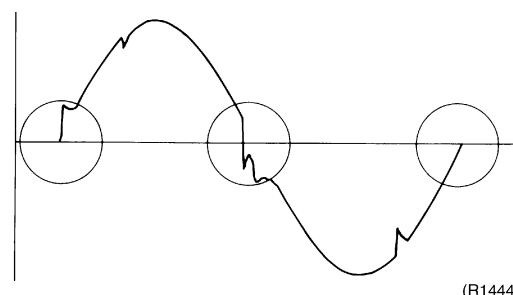

(R1444)

5.1.8 Inverter Units Refrigerant System Check

Check No.11

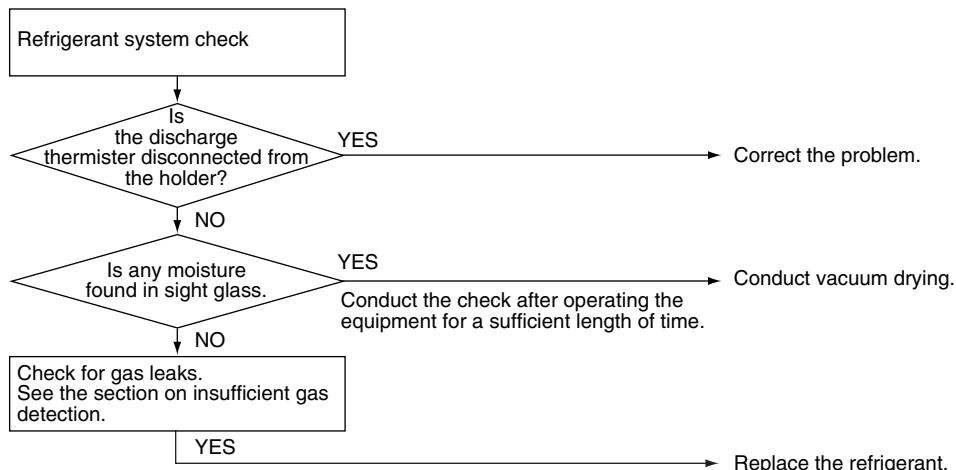

(R1445)

5.1.9 Power Transistor Check

Check No.13



Note: Check to make sure that the voltage between the terminal of Power transistor (+) and (-) is approx. 0 volt before checking power transistor.

< Measuring method >

Disconnect the compressor harness connector from the outdoor unit PCB. To disengage the connector, press the protrusion on the connector.

Then, follow the procedure below to measure resistance between power transistor (+) and (-) and the U, V and W terminals of the compressor connector with a multi-tester. Evaluate the measurement results for a pass/fail judgment.

<Power transistor check>

Negative (-) terminal of tester (positive terminal (+) for digital tester)	Power transistor (+)	UVW	Power transistor (-)	UVW
Positive (+) terminal of tester (negative terminal (-) for digital tester)	UVW	Power transistor (+)	UVW	Power transistor (-)
Normal resistance	Several kΩ to several MΩ (*)			
Unacceptable resistance	Short (0 Ω) or open			

5.1.10 Turning Speed Pulse Input on the Outdoor Unit PCB Check

Check No.15

<Propeller fan motor>

Make sure the voltage of $270\pm 30V$ is being applied.

- (1) Stop the operation first and then the power off, and disconnect the connector S70.
- (2) Make sure there is about DC 270 V between pins 4 and 7.
- (3) With the system and the power still off, reconnect the connector S70.
- (4) Make a turn of the fan motor with a hand, and make sure the pulse (0-15 V) appears twice at pins 1 and 4.

If the fuse is blown out, the outdoor-unit fan may also be in trouble. Check the fan too.

If the voltage in Step (2) is not applied, it means the PCB is defective. Replace the PCB.

If the pulse in Step (4) is not available, it means the Hall IC is defective. Replace the DC fan motor. If there are both the voltage (2) and the pulse (4), replace the PCB.

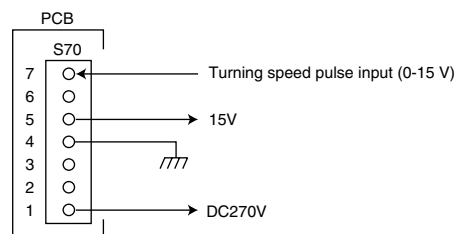

(R2859)

* Propeller fan motor : S70

5.1.11 Hall IC Check

Check No.16

1. Check the connector connection.
2. With the power ON, operation OFF, and the connector connected, check the following.
 - *Output voltage of about 5 V between pins 1 and 3.
 - *Generation of 3 pulses between pins 2 and 3 when the fan motor is operating.

Failure of (1) → faulty PCB → Replace the PCB.

Failure of (2) → faulty hall IC → Replace the fan motor.

Both (1) and (2) result → Replace the PCB.

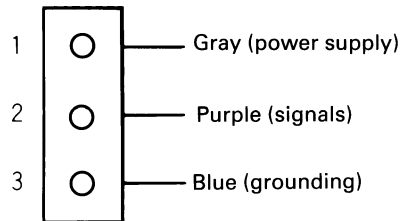

(R1968)

Part 7

Removal Procedure

1. Indoor Unit.....	122
1.1 Removal of the Air Filter / Front Grille	122
1.2 Removal of the Front Panel.....	125
1.3 Removal of the Horizontal Blade.....	127
1.4 Removal of the Signal Receiver Unit / Swing Motor.....	128
1.5 Removal of the Discharge Grille.....	129
1.6 Removal of the Drain Pan	130
1.7 Removal of the Electrical Box / PCB.....	131
1.8 Removal of the Fan Rotor / Fan Motor.....	134
1.9 Removal of the Heat Exchanger	136
2. Outdoor Unit.....	138
2.1 Removal of Panels and Fan Motor.....	138
2.2 Removal of Electrical Box	145
2.3 Removal of Reactor and Partition Plate	147
2.4 Removal of Sound Blanket.....	149
2.5 Removal of Four Way Valve.....	151
2.6 Removal of Compressor.....	153
2.7 Removal of PCB.....	155

1. Indoor Unit

1.1 Removal of the Air Filter / Front Grille

Procedure



Warning Be sure to wait 10 minutes or more after turning off all power supplies before disassembling work.

Step	Procedure	Points
<p>1. Features</p> <ul style="list-style-type: none"> ■ Ceiling-suspended type and floor-mounted type are provided. ■ Explanation will be given by taking the ceiling-suspended type as an example. 		<p>Notes: Removal procedure for the floor-mounted type is same as the ceiling-suspended type.</p>
<p>2. Remove the air filters.</p> <p>1 Pull protrusions on left and right sides with fingers and open the front grille.</p>		

Step	Procedure	Points
2	Holding the tab at the center of filter frame, pull the air filter forward.	
3	Remove the air filter by pulling along the slide guide.	<ul style="list-style-type: none"> ■ Installing filters can be done easily by sliding-in along the slide guide.
3. Remove the front grille.		
1	Disengage the two hooks (left and right sides), using screw driver.	

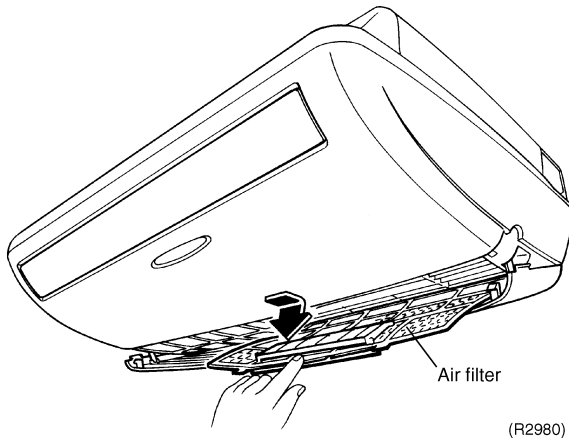

(R2980)

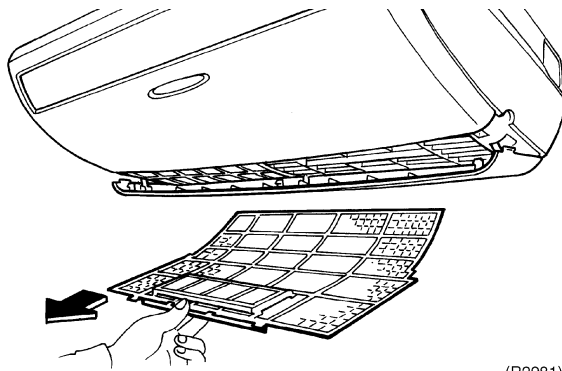

(R2981)

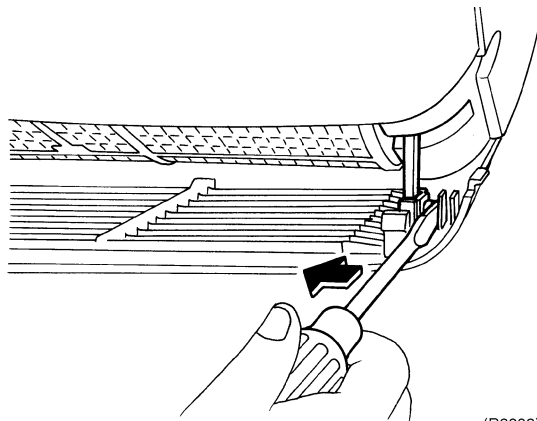

(R2982)

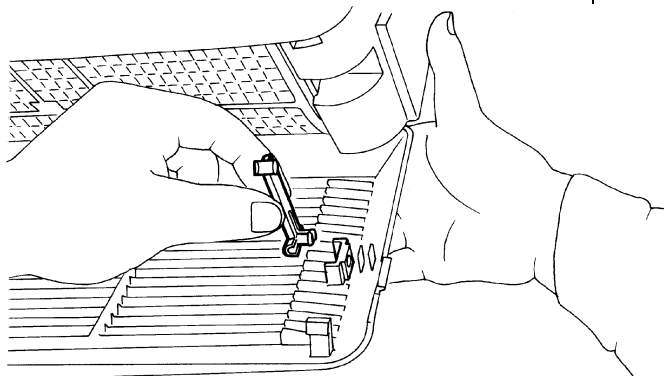

(R2983)

Step	Procedure	Points
2	To remove the front grille, disengage hooks at three locations.	
(R2984)		
4. Remove the side panel cover .	<p>1 Remove the side panel cover for removing of suspension parts.</p> <p>Note: If it is difficult to remove side panel from outside with finger, remove front panel first, then push side panel from inside of unit to outside.</p>	
(R2985)		

1.2 Removal of the Front Panel

Procedure



Warning Be sure to wait 10 minutes or more after turning off all power supplies before disassembling work.

Step	Procedure	Procedure	Points
1	Remove the four screws located at the back of the front panel.	<p>Front panel</p> <p>(R2986)</p>	<p>Notes: For the ceiling-suspended type, remove drain hose before removing the screws.</p>
2	Remove the three screw covers at the front of the front panel.	<p>To open the screw cover</p> <p>(R2987)</p>	
3	Remove the three screws.	<p>(R2988)</p>	

Step	Procedure	Points
4	Disengage the three hooks of the front panel located at discharge port.	
5	Press A-section slightly at the center of the front panel, and disengage hook.	
6	Remove the front panel.	<p>⚠ Caution For ceiling-suspended type, be careful that the front panel may fall when hooks are disengaged. To prevent the front panel from falling down, this service work should be done by two persons.</p>

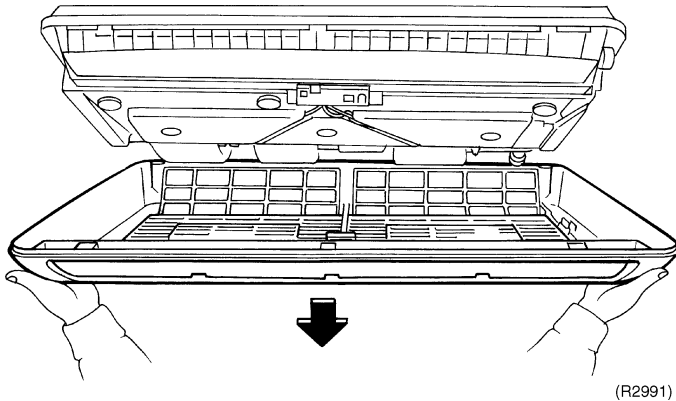
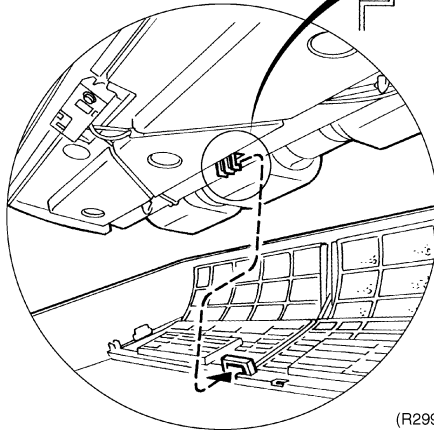
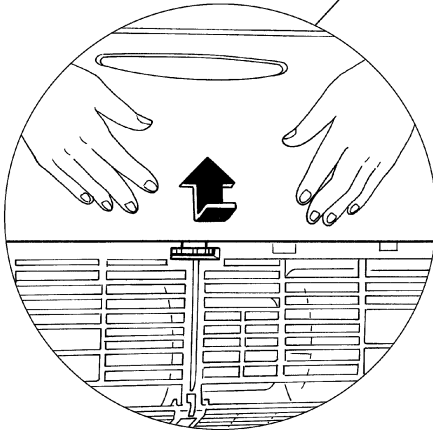
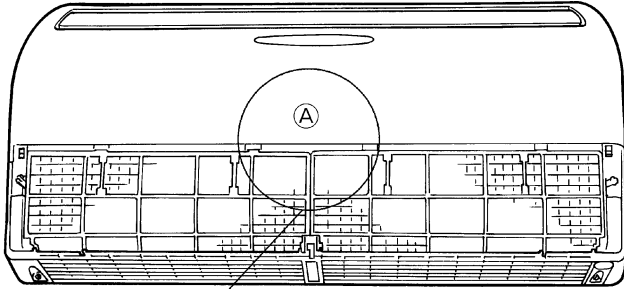
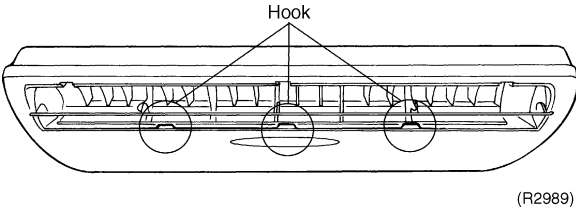

1.3 Removal of the Horizontal Blade

Procedure



Warning Be sure to wait 10 minutes or more after turning off all power supplies before disassembling work.

Step	Procedure	Procedure	Points
1	Open the horizontal blade .	<p>(R2992)</p>	
2	Deflect the three center bearings to left side slightly, and disengage shaft of blade.	<p>(R2993)</p>	
3	Bend the blade slightly to disengage shafts from bearings at both ends. (Remove the left side shaft first.)	<p>(R2994)</p>	

1.4 Removal of the Signal Receiver Unit / Swing Motor

Procedure

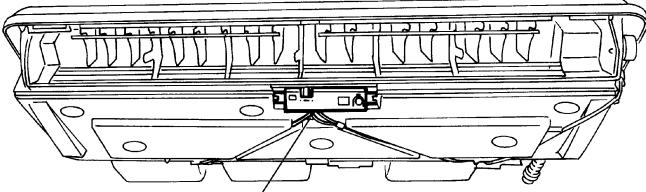
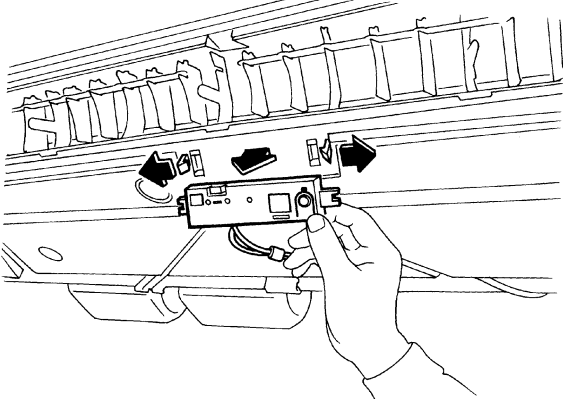
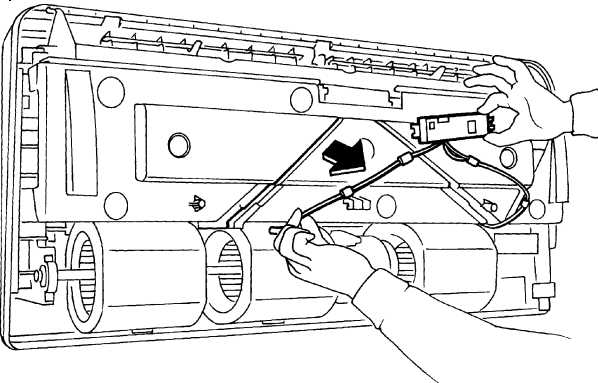
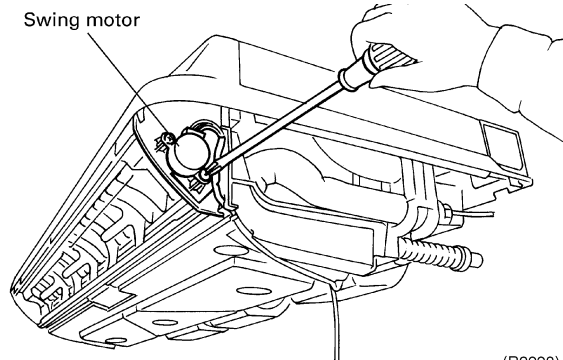

Warning Be sure to wait 10 minutes or more after turning off all power supplies before disassembling work.

Step	Procedure	Points
<p>1. Remove the signal receiver unit.</p> <p>1 Disengage the two hooks (left and right sides) to remove the signal receiver unit.</p> <p>2 Remove the wire harness of the signal receiver from the groove.</p>	 <p style="text-align: center;">Signal receiver unit</p> <p style="text-align: right;">(R2995)</p>  <p style="text-align: right;">(R2996)</p>  <p style="text-align: right;">(R2997)</p>	<p>Note: Rearrange the wire harness in position as it was when reassembling signal receiver unit.</p>
<p>2. Remove the swing motor.</p> <p>1 Remove the two screws holding the swing motor in place.</p>	 <p style="text-align: center;">Swing motor</p> <p style="text-align: right;">(R2998)</p>	

1.5 Removal of the Discharge Grille

Procedure



Warning Be sure to wait 10 minutes or more after turning off all power supplies before disassembling work.

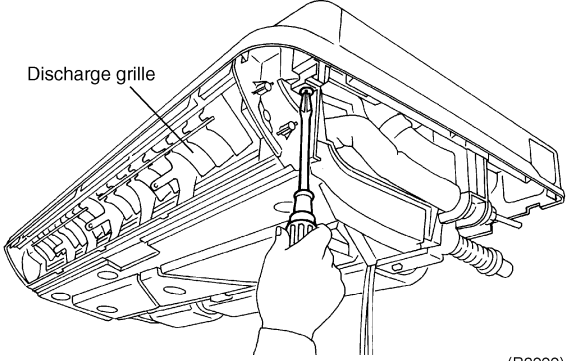
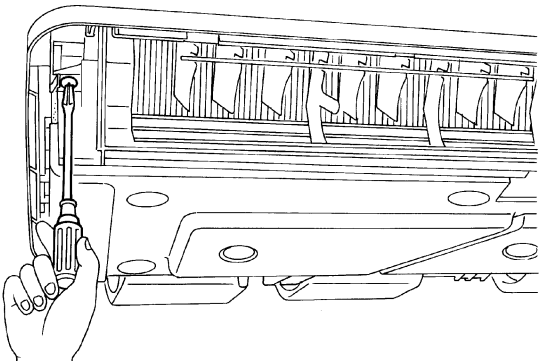
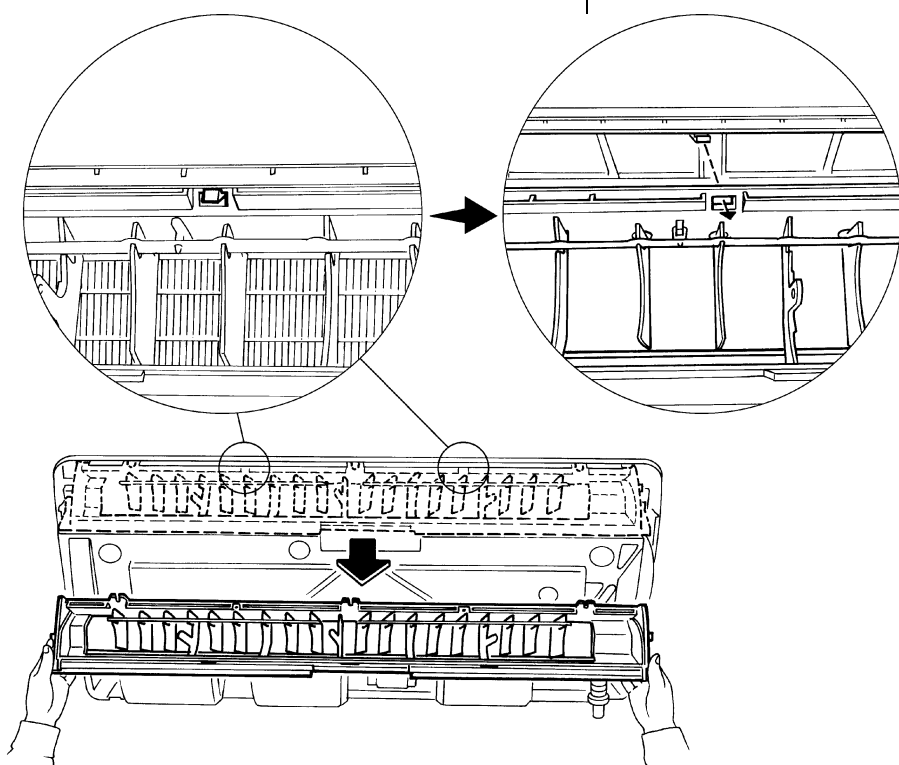

Step	Procedure	Procedure	Points
1	Remove the two screws securing discharge grille.	 <p>(R2999)</p>  <p>(R3000)</p>	
2	Disengage the two hooks (left and right sides) and remove the discharge grille by pulling forward.	 <p>(R3001)</p>	

1.6 Removal of the Drain Pan

Procedure

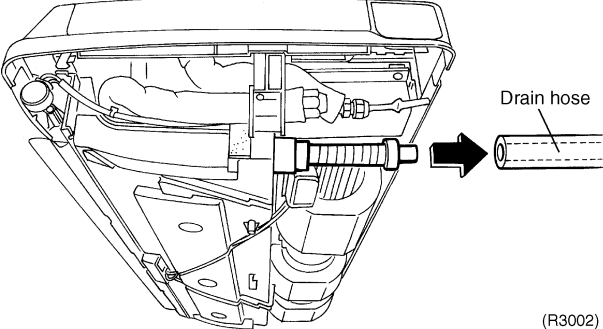

Warning Be sure to wait 10 minutes or more after turning off all power supplies before disassembling work.

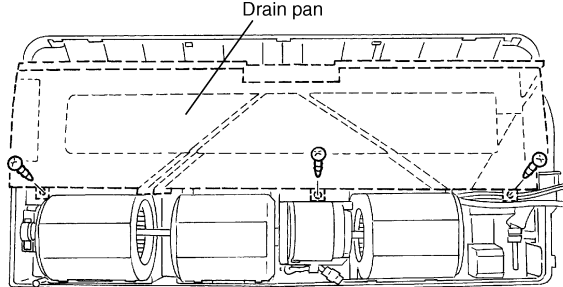
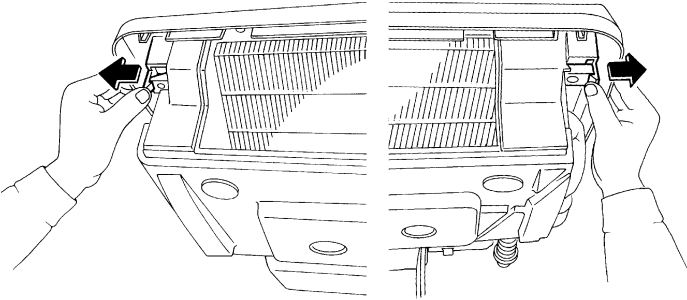
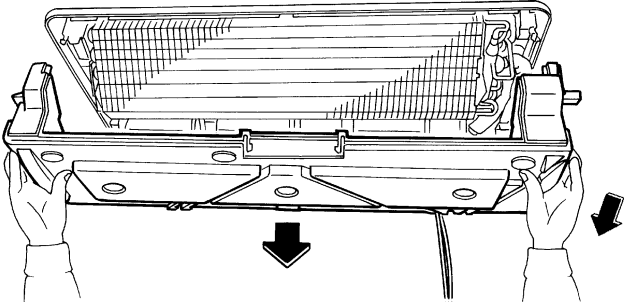
Step	Procedure	Procedure	Points
1	Disconnect the drain hose.	 <p style="text-align: right;">(R3002)</p>	 <p>Caution Be careful not to wet the floor with drain water.</p>
2	Remove the three screws securing the suction side of the drain pan.	 <p style="text-align: center;">Drain pan</p> <p style="text-align: right;">(R3003)</p>	
3	Disengage the two hooks located at both left and right sides of discharge port.	 <p style="text-align: right;">(R3004)</p>	
4	Slide the drain pan toward the suction side and remove it.	 <p style="text-align: right;">(R3005)</p>	

1.7 Removal of the Electrical Box / PCB

Procedure

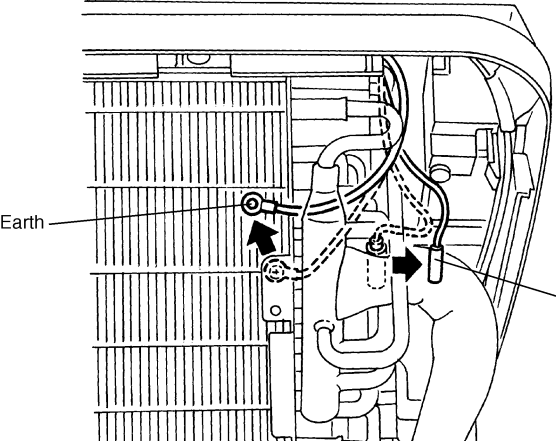
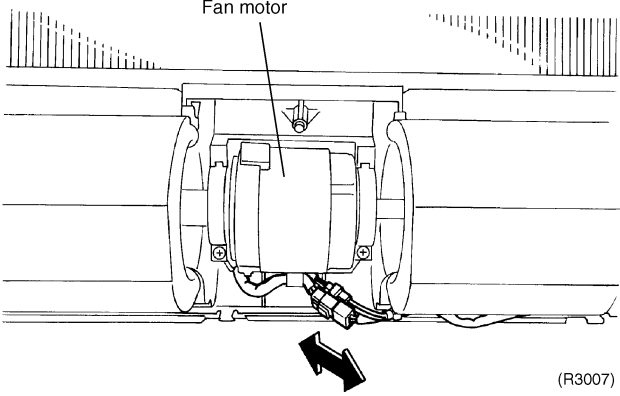
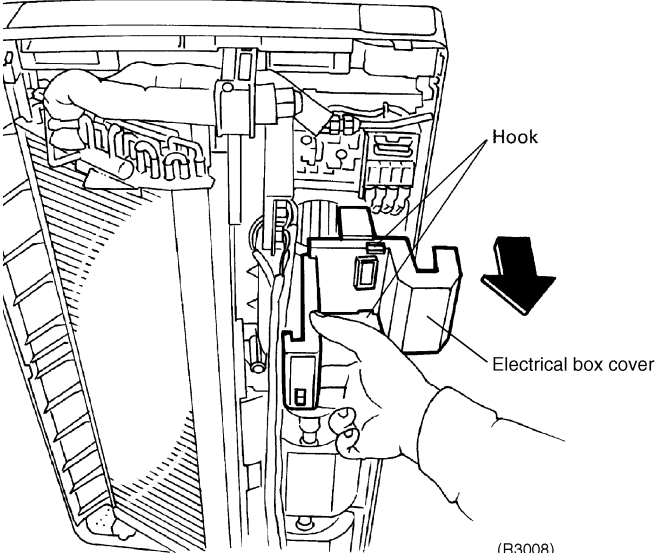

Warning Be sure to wait 10 minutes or more after turning off all power supplies before disassembling work.

Step	Procedure	Points
<p>1. Remove the PCB.</p> <p>1 Disconnect the earth wire and the indoor heat exchanger thermistor harness.</p> <p>2 Remove the two connection wirings at the rear side of the fan motor.</p> <p>3 Remove the electrical box cover. (Disengage the two hooks.)</p>	  	<p>(R3006)</p> <ul style="list-style-type: none"> ■ Clamp harnesses and wires with clips as they were when reassembling. Negligence of above procedure may result in catching wire with front cover and causes malfunction.

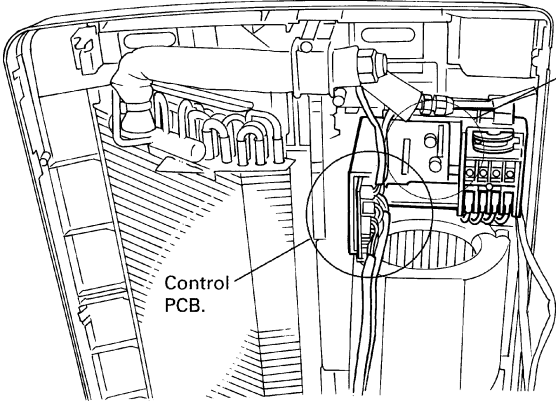
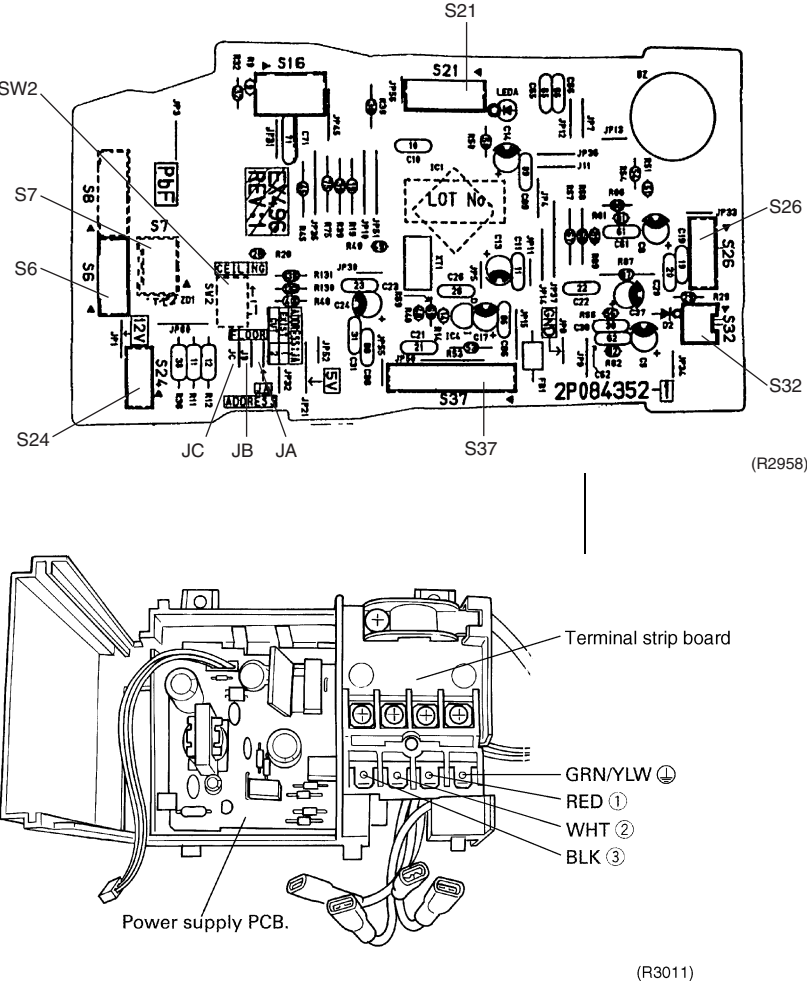
Step	Procedure	Points
4	The illustration shows the control PCB (indoor unit) .	 <p>Control PCB.</p> <p>Power supply PCB.</p> <p>(R3009)</p>
5	Disconnect the terminals from the terminal strip board .	 <p>SW2, S7, S6, S24, JC, JB, JA, S37, S21, S16, S26, S25, S32, S37, 2P084352, LOT No.</p> <p>Terminal strip board</p> <p>Power supply PCB.</p> <p>GRN/YLW ① RED ② WHT ③ BLK ④</p> <p>(R2958)</p> <p>(R3011)</p>

1.8 Removal of the Fan Rotor / Fan Motor

Procedure



Warning Be sure to wait 10 minutes or more after turning off all power supplies before disassembling work.

Step	Procedure	Procedure	Points
<p>1</p> <p>Remove the three fan rotor covers. (Securing hooks are located at A and B-section.)</p> <p>■ The right illustration shows the opposite side.</p>		<p>A-section</p> <p>Fan rotor</p> <p>Fan rotor cover</p> <p>(R3014)</p> <p>B-section</p> <p>(R3015)</p>	<p>Hooks at A-section</p> <p>Hooks at B-section</p> <p>(R3016)</p>
<p>2</p> <p>Disconnect the two connection wirings located at the rear side of the fan motor and unclamp the harness from the clip.</p>		<p>Fan motor</p> <p>(R3017)</p>	

Step	Procedure	Points
3	Remove the two screws to remove fan motor fixtures.	
4	Remove the bearing fixture.	
5	Loosen the shaft supporting section using a hexagonal wrench (for M6) to remove the fan motor.	

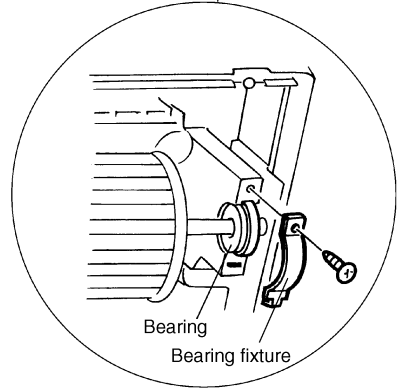
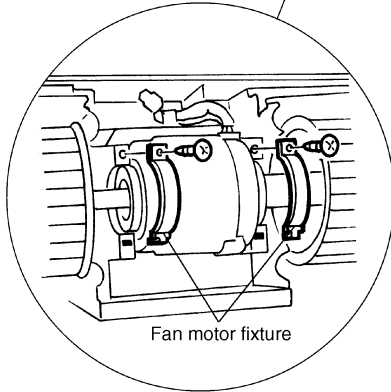
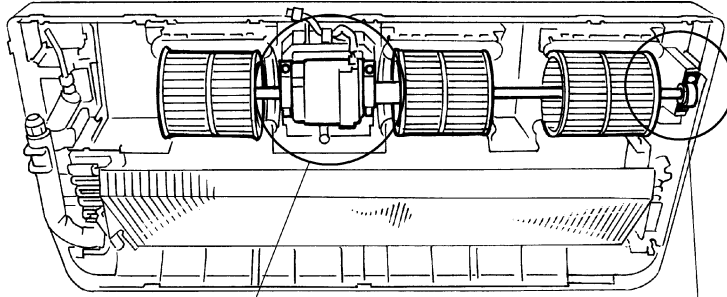

(R3018)

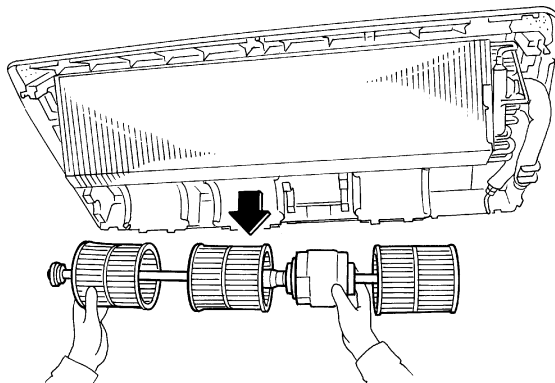

(R3019)

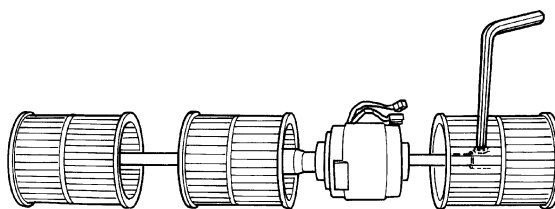

(R3020)

1.9 Removal of the Heat Exchanger

Procedure



Warning Be sure to wait 10 minutes or more after turning off all power supplies before disassembling work.

Step	Procedure	Points
<p>■ Be sure to conduct pump down operation before disassembling refrigerant pipe.</p>		
<p>1 Disconnect the pipe at the heat exchanger side for the auxiliary flexible tube.</p>		<p>(R3021)</p> <p>■ To prevent the heat exchanger from falling down, the service work should be done by two persons.</p>
<p>2 Remove the two screws for piping fixture.</p>		
<p>3 Remove the two screws at the pipe header side of the heat exchanger.</p>		<p>(R302)</p> <p>Caution When removing or reinstalling heat exchanger, be sure to wear protective gloves or wrap heat exchanger with cloths. (Fins can cut fingers.)</p>

Step	Procedure	Points
4	Hooking piece is located on the piping side of the heat exchanger.	<p>Warning Do not contaminate any gas (including air) other than the specified refrigerant (R-410A) into refrigerating cycle. (Contaminating of air or other gas causes abnormal temperature rise in refrigerating cycle, and this results in pipe breakage or personal injuries.)</p>
5	Remove screws at left side, then move heat exchanger to the right.	<p>Warning If gas leaks, repair the spot of leaking, then collect all refrigerant from the unit. After conducting vacuum drying, and charge proper amount of refrigerant.</p>
6	Remove the heat exchanger.	<p>Caution When removing or reinstalling heat exchanger, be sure to wear protective gloves or wrap the heat exchanger with cloths. (Fins can cut fingers.)</p>

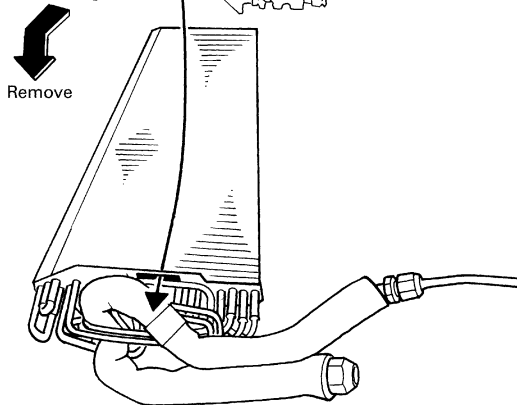
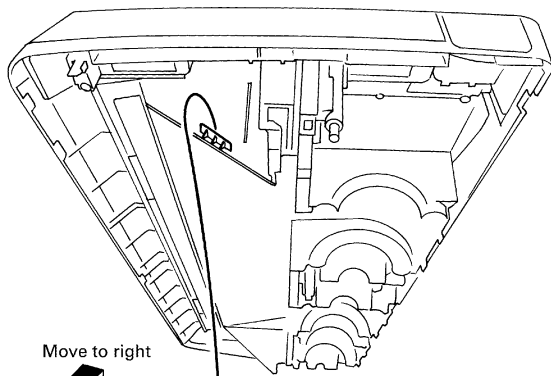

(R3023)

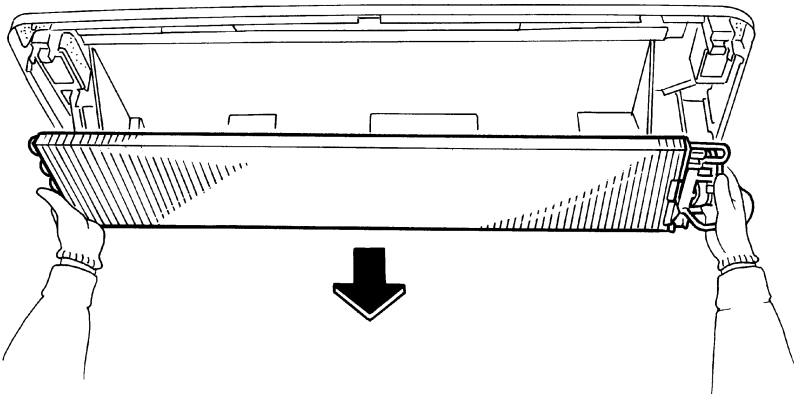

(R3024)

2. Outdoor Unit

2.1 Removal of Panels and Fan Motor

Procedure



Warning Be sure to wait 10 minutes or more after turning off all power supplies before disassembling work.

Step	Procedure	Points
<p>1. Features</p> <p>1 Loosen the screw of the stop valve cover. Pull down the stop valve cover and remove it.</p>	<p>Handle</p> <p>(R3235)</p> <p>Outdoor air thermistor</p> <p>(R3236)</p> <p>Stop valve cover</p> <p>(R3237)</p> <p>Shelter</p> <p>Hooks</p> <p>(R3238)</p>	<ul style="list-style-type: none"> ■ Take care not to cut your finger by the fins of the heat exchanger. ■ The stop valve cover is united with the shelter. ■ When reassembling, make sure to fit the 5 hooks.

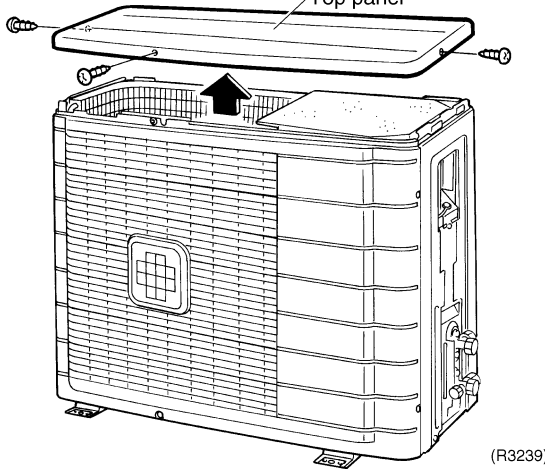
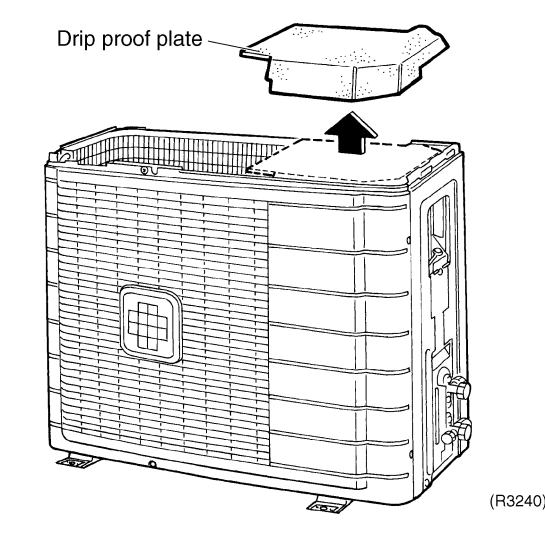
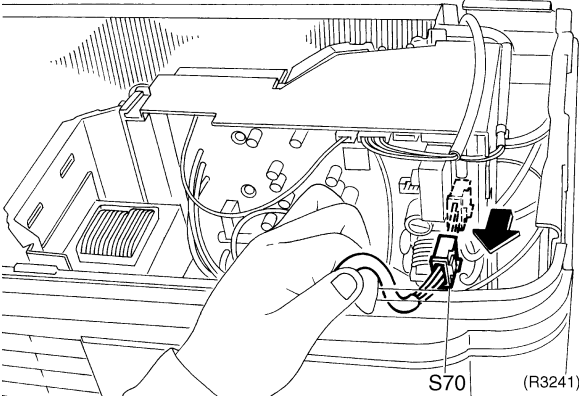
Step	Procedure	Points
2. Remove the panels.		
1	<p>Loosen the 3 screws (front, right, left) and lift the top panel.</p> 	
2	<p>Remove the drip proof plate.</p> 	
3	<p>Disconnect the connector for fan motor (S70).</p> 	<p>■ The fan motor is united with the front panel.</p>
4	<p>Loosen the 5 screws of the front panel.</p> 	

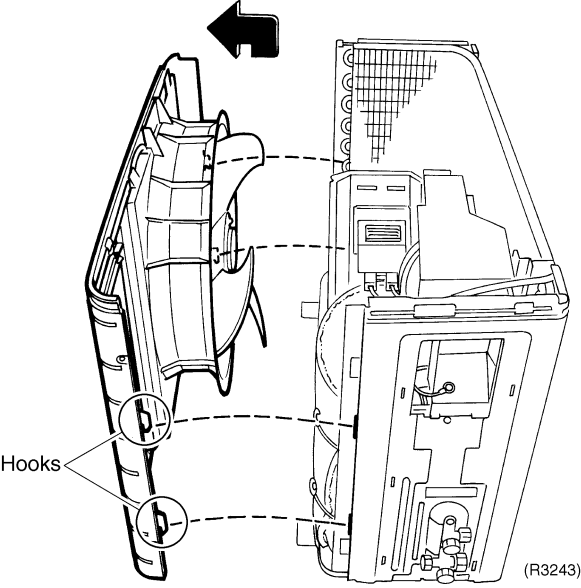
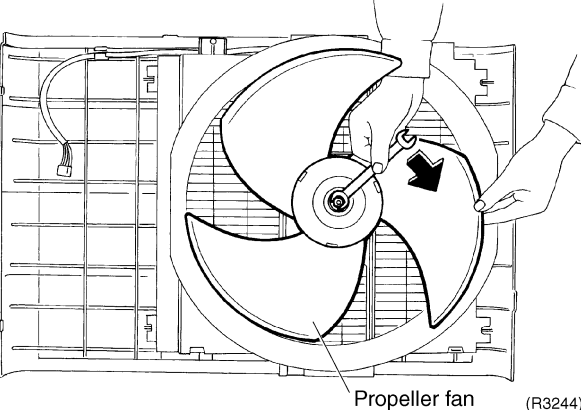
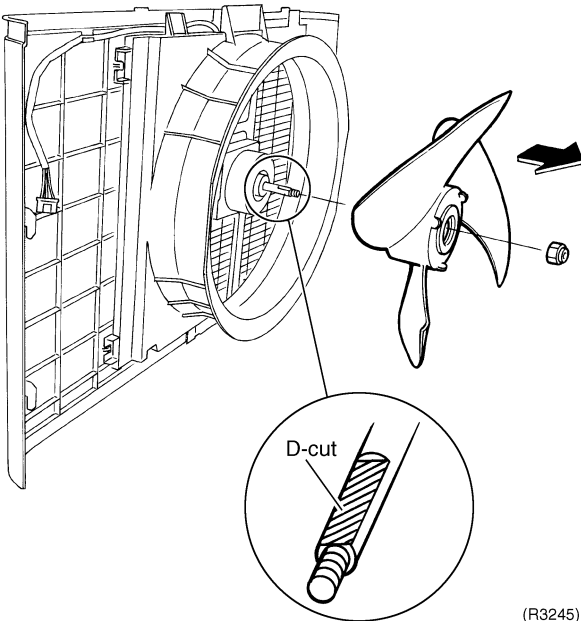
Step	Procedure	Points
5	<p>Undo the hooks. Pull and remove the front panel.</p> 	<ul style="list-style-type: none"> ■ The front panel has 4 hooks. ■ The fan motor is united with the front panel.
3.	<p>Remove the fan motor.</p> <p>1 Unscrew the washer-fitted nut (M10) of the propeller fan with a spanner.</p>  <p>2 Remove the propeller fan.</p> 	<ul style="list-style-type: none"> ■ The screw has reverse winding. ■ Align ▼ mark of the propeller fan with D-cut section of the motor shaft when reassembling.

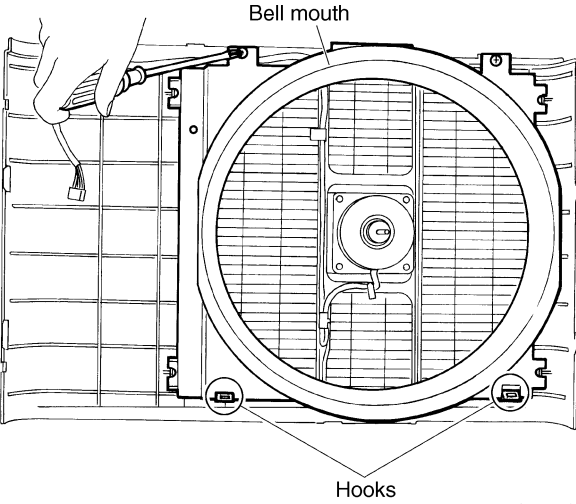
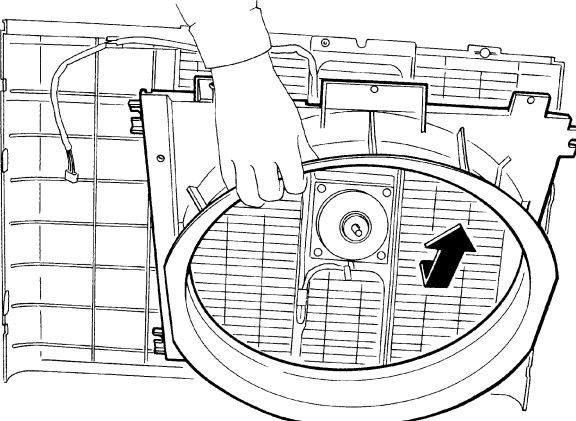
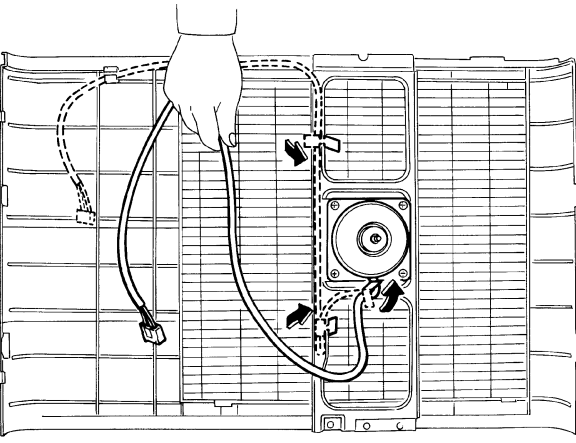
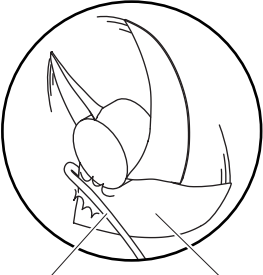
Step	Procedure	Points
<p>3</p> <p>Loosen the 2 screws and lift the bell mouth to undo the hooks. Remove the bell mouth.</p>	 <p>Bell mouth</p> <p>Hooks</p> <p>(R3246)</p>  <p>(R3247)</p>	
<p>4</p> <p>Loosen the fixing hooks and release the lead wire.</p>	 <p>(R3248)</p>	<ul style="list-style-type: none"> ■ Put the lead wire through the back of the motor when reassembling. (so as not to be entangled with the propeller fan)  <p>Lead wire Propeller fan</p> <p>(R3249)</p>

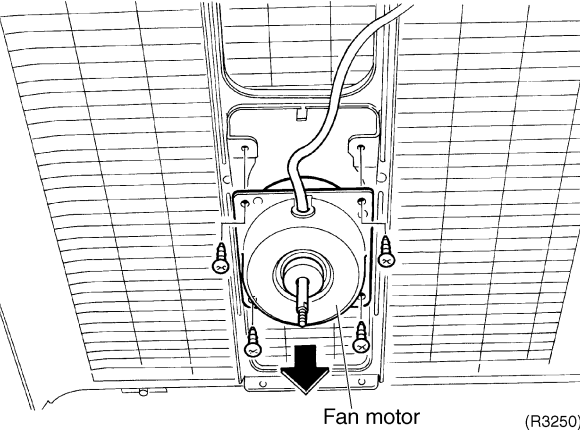
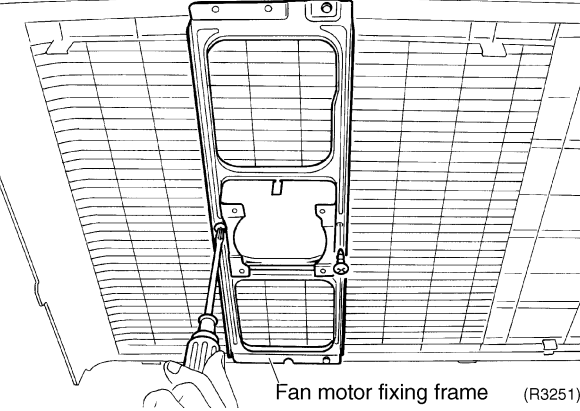
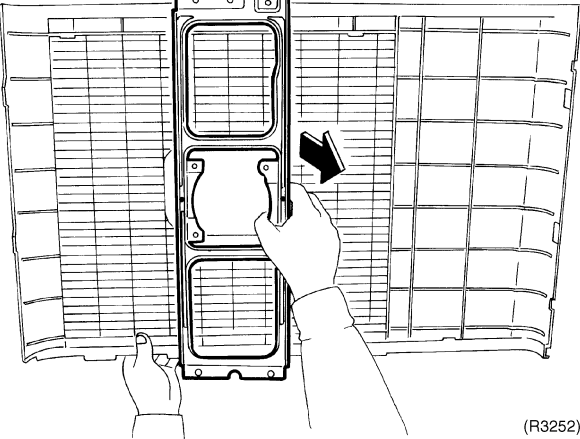
Step	Procedure	Points
5	<p>Loosen the 4 screws to remove the fan motor.</p> 	<ul style="list-style-type: none"> ■ M4×16 ■ DC fan motor
6	<p>Loosen the 2 screws to remove the fan motor fixing frame.</p>  	

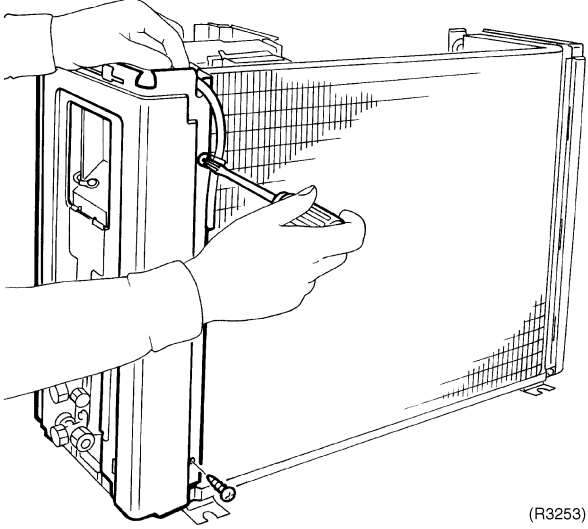
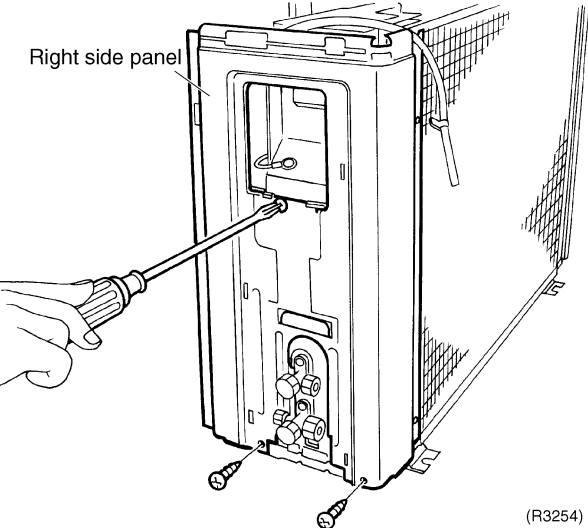
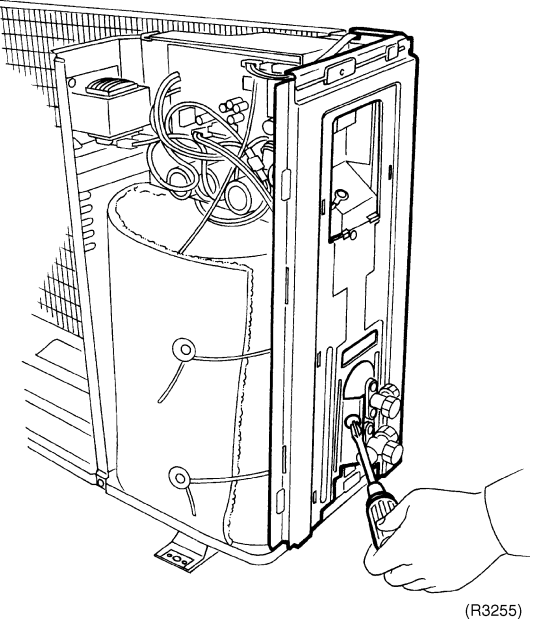
Step	Procedure	Points
4. Remove the right side panel.		
1	<p>Loosen the 2 screws on the rear side.</p>  <p>(R3253)</p>	
2	<p>Loosen the 3 screws on the right side.</p>  <p>Right side panel</p> <p>(R3254)</p>	
3	<p>Loosen the screw and lift the connection port to remove.</p>  <p>(R3255)</p>	

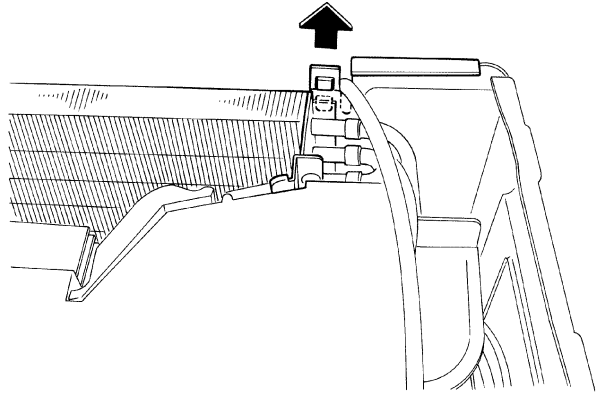
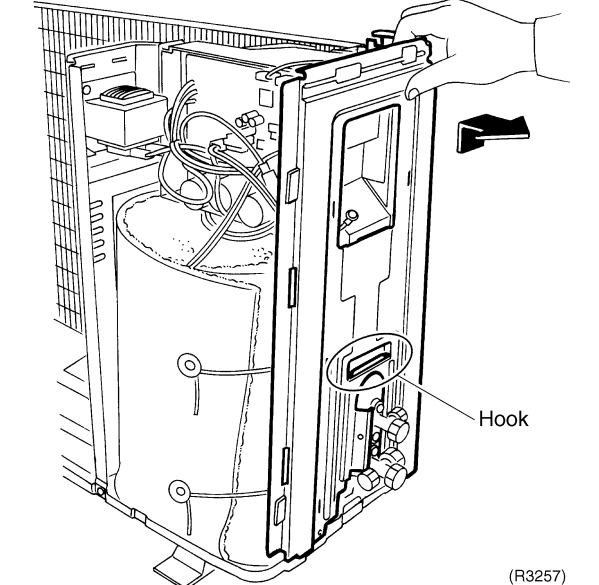
Step	Procedure	Points
	 <p>(R3256)</p>  <p>Hook</p> <p>(R3257)</p>	<ul style="list-style-type: none"> ■ When reassembling, make sure to fit the hook.

2.2 Removal of Electrical Box

Procedure

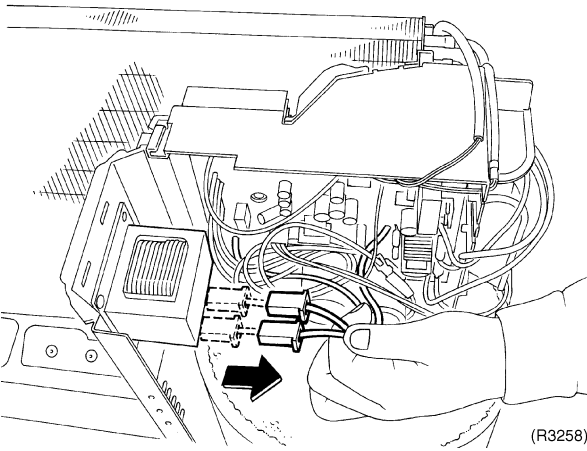
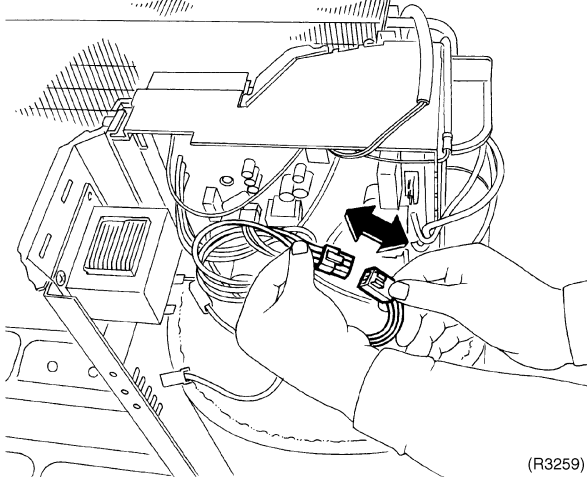
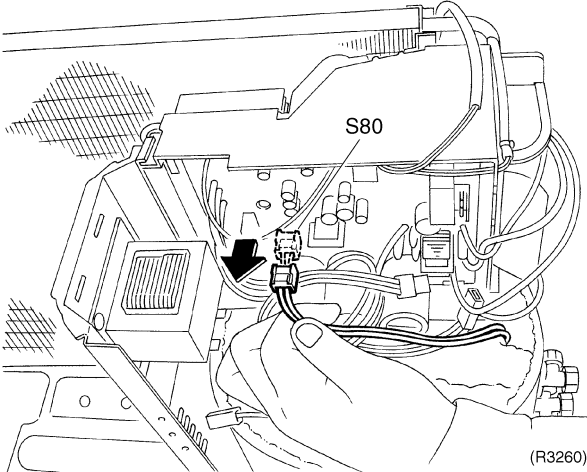

Warning Be sure to wait 10 minutes or more after turning off all power supplies before disassembling work.

Step	Procedure	Points
<ul style="list-style-type: none"> ■ Remove the top panel. ■ Disconnect the connector for fan motor. 	 <p style="text-align: right;">(R3258)</p>	
1. Remove the electrical box.		
1 Disconnect the 2 reactor harnesses.		
2 Disconnect the relay connector for compressor lead wire.	 <p style="text-align: right;">(R3259)</p>	
3 Disconnect the connector for four way valve (S80).	 <p style="text-align: right;">(R3260)</p>	<ul style="list-style-type: none"> ■ When reassembling, coil the excessive lead wire and hang off the hook.

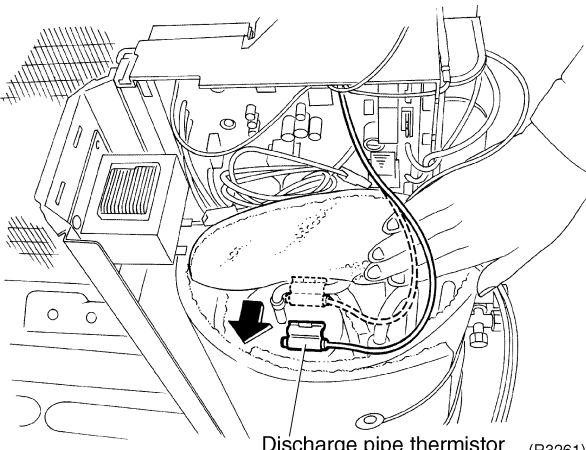
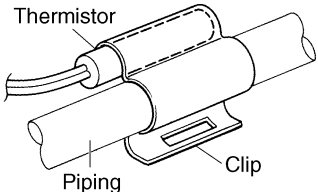
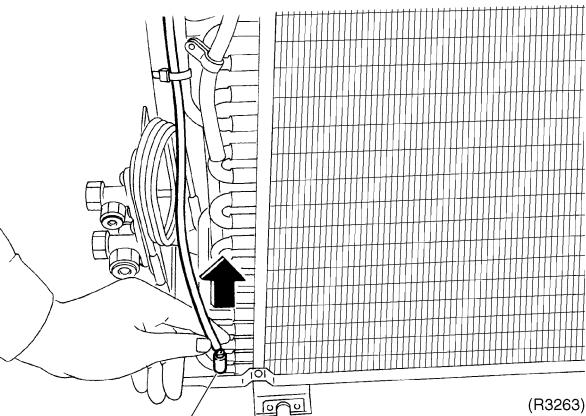
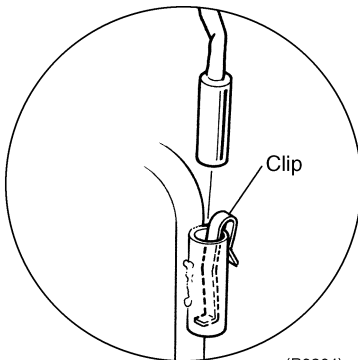
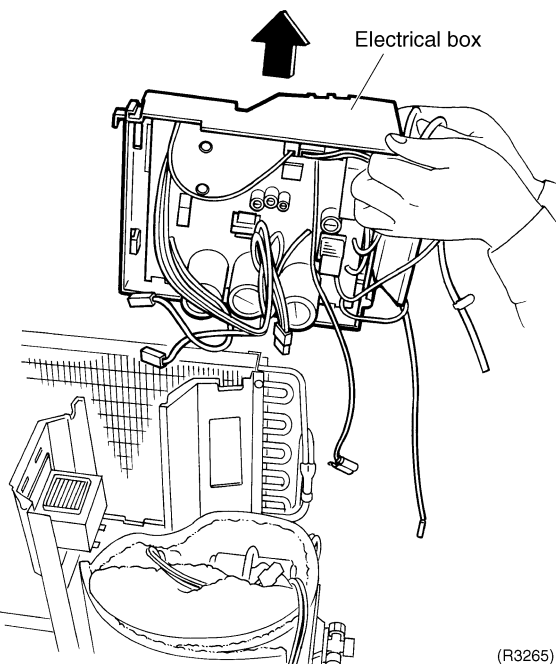
Step	Procedure	Procedure	Points
4	Release the discharge pipe thermistor.	 <p>Discharge pipe thermistor (R3261)</p>	<ul style="list-style-type: none"> ■ Pay attention so as not to lose the clip for thermistor.  <p>(R3262)</p>
5	Release the heat exchanger thermistor.	 <p>Heat exchanger thermistor (R3263)</p>	<ul style="list-style-type: none"> ■ Pay attention so as not to lose the clip.  <p>(R3264)</p>
6	Lift and remove the electrical box.	 <p>Electrical box (R3265)</p>	

2.3 Removal of Reactor and Partition Plate

Procedure

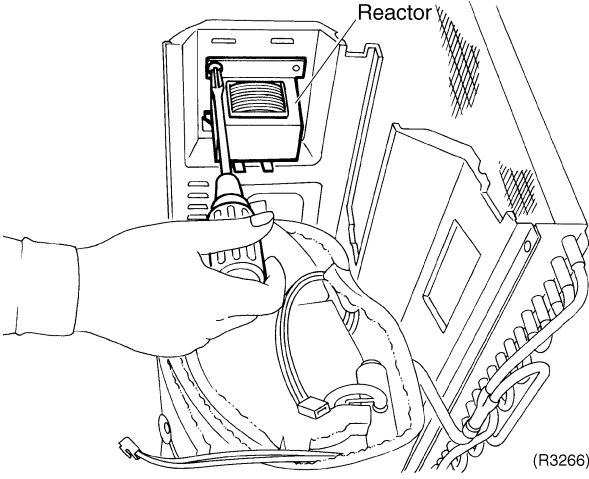
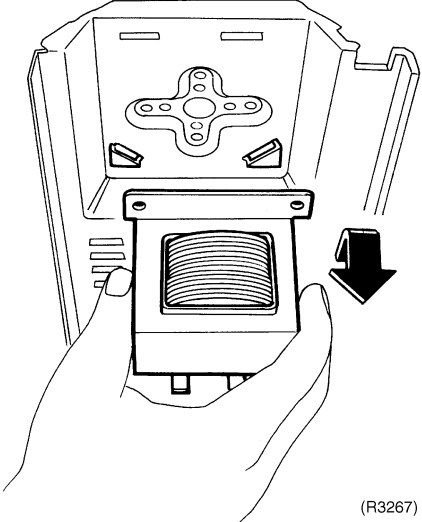
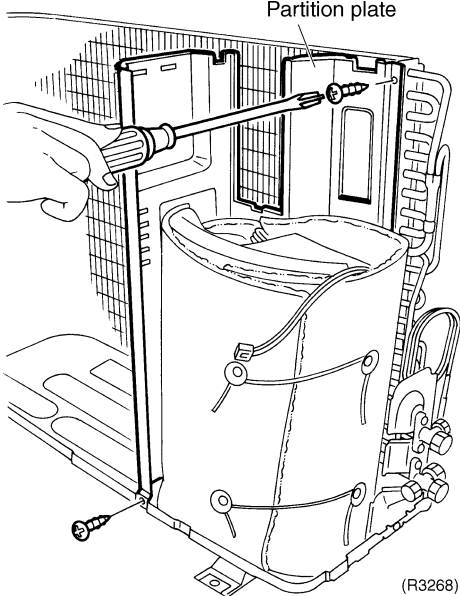

Warning Be sure to wait 10 minutes or more after turning off all power supplies before disassembling work.

Step	Procedure	Points
<ul style="list-style-type: none"> ■ Remove the outer panels. ■ Remove the electrical box. 		
<p>1. Remove the reactor.</p>		
<p>1 Loosen the screw. Lift and remove the reactor.</p>	 	
<p>2. Remove the partition plate.</p>		
<p>1 Loosen the 2 screws.</p>		

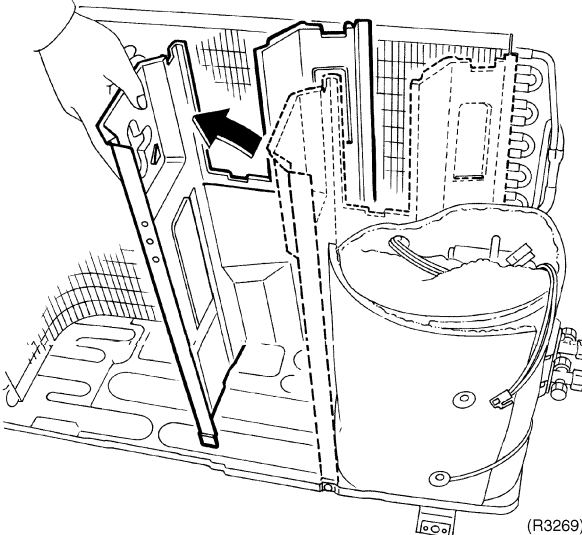
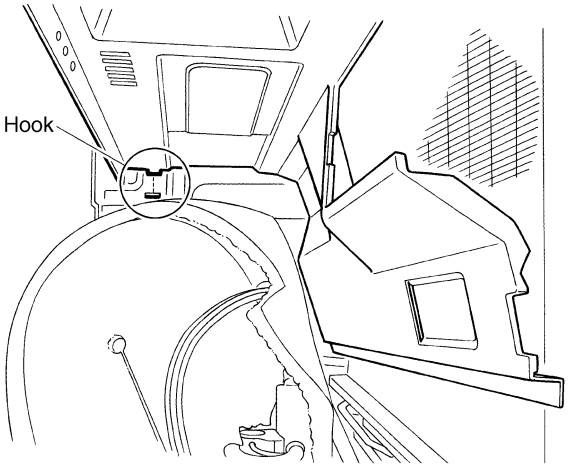
Step	Procedure	Points
<p>2</p>	<p>The partition plate has a hook on the lower side. Lift and pull the partition plate to remove.</p>  <p>(R3269)</p>  <p>(R3270)</p>	<ul style="list-style-type: none"> ■ When reassembling, fit the lower hook into the bottom frame.

2.4 Removal of Sound Blanket

Procedure



Warning Be sure to wait 10 minutes or more after turning off all power supplies before disassembling work.

Step	Procedure	Points
<ul style="list-style-type: none"> ■ Remove the outer panels. ■ Remove the electrical box. 		
<p>1. Remove the sound blanket.</p>		
<p>1 Untie the strings and open the sound blanket.</p>	<p style="text-align: center;">Sound blanket</p> <p style="text-align: right;">(R3271)</p>	
<p>2 Lift and remove the sound blanket (body) as it is opened.</p>	<p style="text-align: right;">(R3272)</p>	<ul style="list-style-type: none"> ■ Since the piping ports on the sound blanket are torn easily, remove the blanket carefully.
<p>3 Lift and remove the sound blanket (top).</p>	<p style="text-align: right;">(R3273)</p>	

Step	Procedure	Points
4	Pull the sound blanket (inner) out.	<ul style="list-style-type: none"> ■ Since the piping ports on the sound blanket are torn easily, remove the blanket carefully.
5	Pull the sound blanket (bottom) out.	

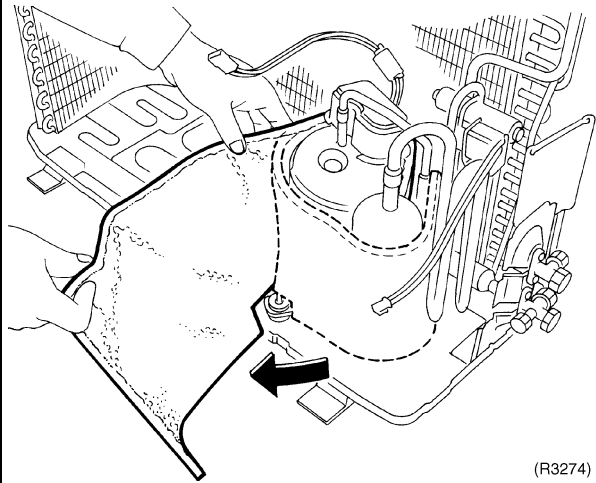

(R3274)

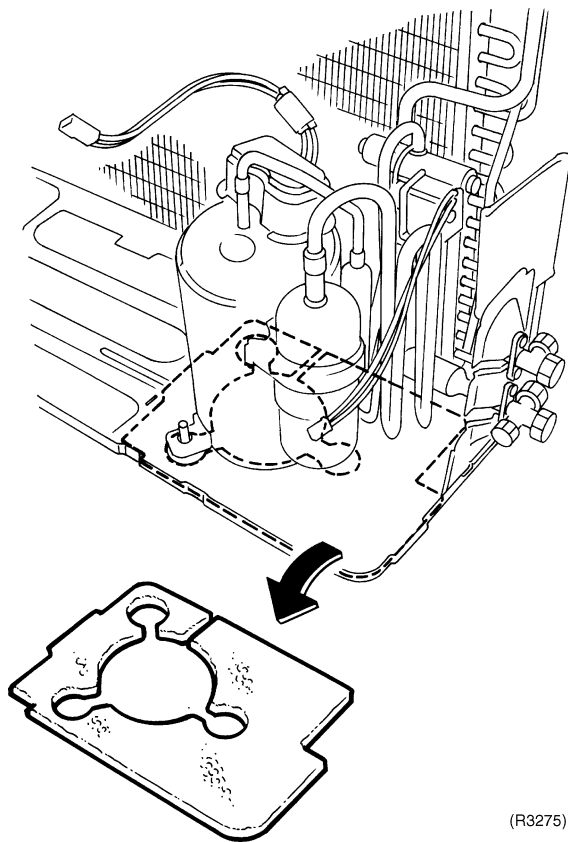

(R3275)

2.5 Removal of Four Way Valve

Procedure

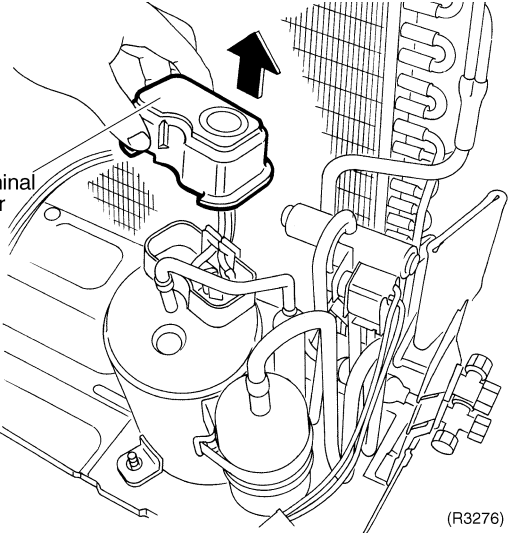
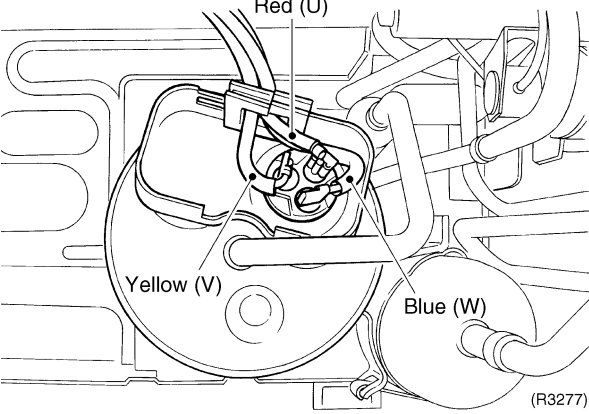
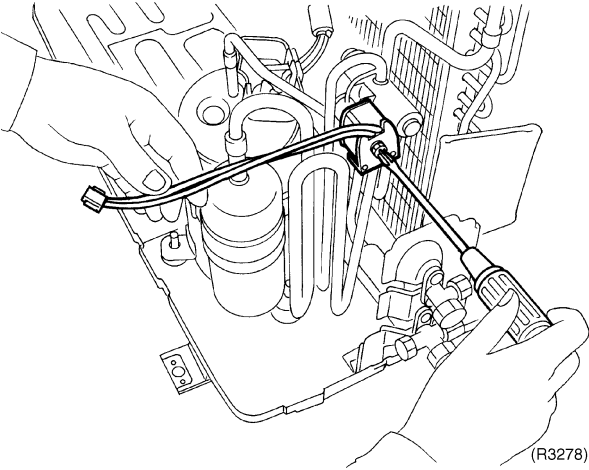

Warning Be sure to wait 10 minutes or more after turning off all power supplies before disassembling work.

Step	Procedure	Points
1. Remove the peripheries.	<p data-bbox="197 400 467 528"> ■ Remove the four way valve and the sheets of putty so as not to burn them. </p>  <p data-bbox="504 546 560 589">Terminal cover</p> <p data-bbox="1002 882 1058 902">(R3276)</p>	<p data-bbox="1094 871 1452 965"> ■ Be careful so as not to burn the compressor terminals or the name plate. </p>
1 Remove the terminal cover.	 <p data-bbox="740 936 815 956">Red (U)</p> <p data-bbox="612 1211 703 1232">Yellow (V)</p> <p data-bbox="890 1234 965 1254">Blue (W)</p> <p data-bbox="1018 1330 1074 1350">(R3277)</p>	<p data-bbox="1094 1003 1233 1032">Make notes.</p>
2 Loosen the screw of the four way valve coil.	 <p data-bbox="1018 1832 1074 1852">(R3278)</p>	

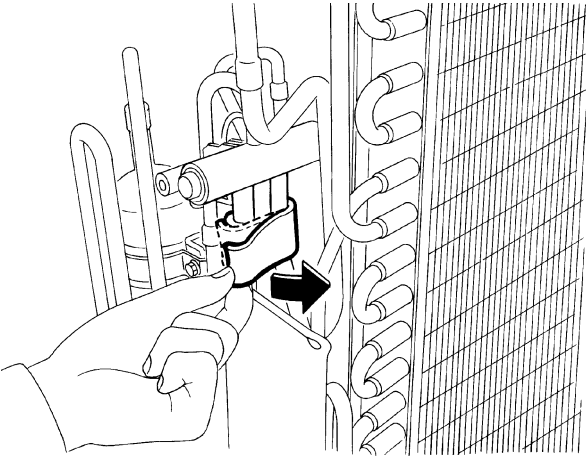
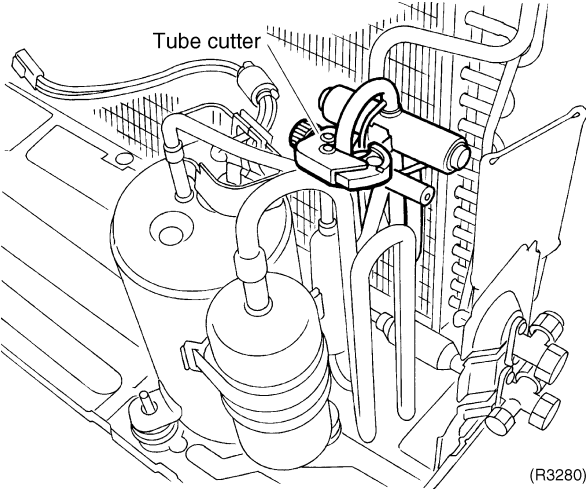
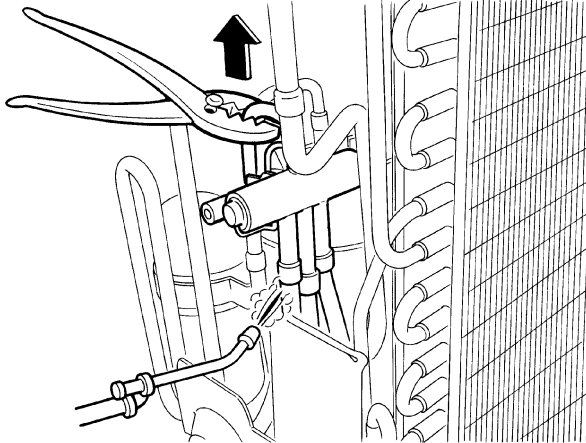
Step	Procedure	Points
<p>3</p> <p>Remove the sheets of putty. Cut the pipe with a tube cutter.</p>	 <p>(R3279)</p>  <p>(R3280)</p>	
<p>4</p> <p>Heat up the brazed part and withdraw the piping with pliers.</p>	 <p>(R3281)</p>	<ul style="list-style-type: none"> ■ Provide a protective sheet or a steel plate so that the brazing flame cannot influence peripheries. ■ Be careful so as not to break the pipes by pressing it excessively by pliers when withdrawing it.

2.6 Removal of Compressor

Procedure



Warning Be sure to wait 10 minutes or more after turning off all power supplies before disassembling work.

Step	Procedure	Points
1.	Remove the compressor.	
1	<p>Unscrew the nut of the compressor.</p> <ul style="list-style-type: none"> ■ Before working, make sure that the refrigerant is empty in the circuit. ■ Be sure to apply nitrogen replacement when heating up the brazed part. 	<p>Warning Ventilate when refrigerant leaks during the work. (If refrigerant contacts fire, it will cause to arise toxic gas.)</p> <ul style="list-style-type: none"> ■ Provide a protective sheet or a steel plate so that the brazing flame cannot influence peripheries. ■ Be careful so as not to burn the compressor terminals or the name plate. ■ Be careful so as not to burn the heat exchanger fin. <p>Warning Since it may happen that refrigeration oil in the compressor will catch fire, prepare wet cloth so as to extinguish fire immediately.</p>
2	<p>Heat up the brazed part of the discharge side and disconnect.</p>	<p>In case of the difficulty with gas brazing machine</p> <ol style="list-style-type: none"> 1. Disconnect the brazed part where is easy to disconnect and restore. 2. Cut pipes on the main unit by a miniature copper tube cutter in order to make it easy to disconnect. <p>Cautions for restoration</p> <ol style="list-style-type: none"> 1. Restore the piping by non-oxidation brazing. 2. It is required to prevent the carbonization of the oil inside the four way valve and the deterioration of the gaskets affected by heat. For the sake of this, wrap the four way valve with wet cloth and provide water so that the cloth will not be dried and avoid excessive heating. (Keep below 120°C) <p>Note: Do not use a metal saw for cutting pipes by all means because the sawdust come into the circuit.</p>

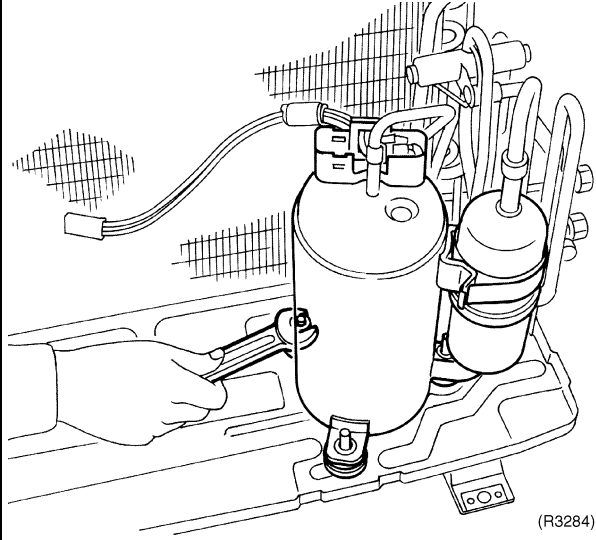

(R3284)

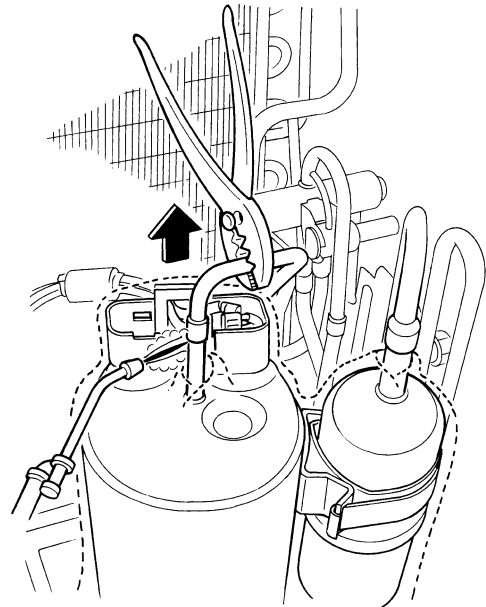

(R3285)

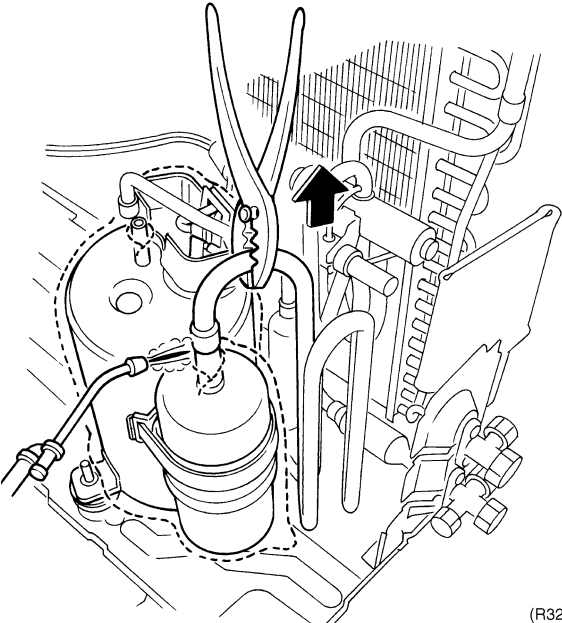
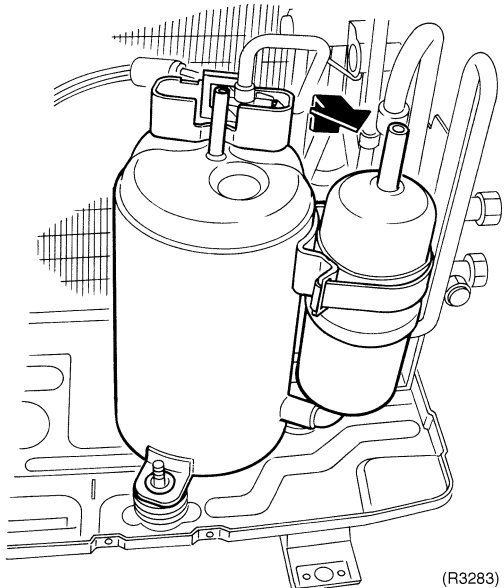
Step	Procedure	Points
3	<p>Heat up the brazed part of the suction side and disconnect.</p>  <p>(R3282)</p>	
4	<p>Lift the compressor up and remove it.</p>  <p>(R3283)</p>	

2.7 Removal of PCB

Procedure

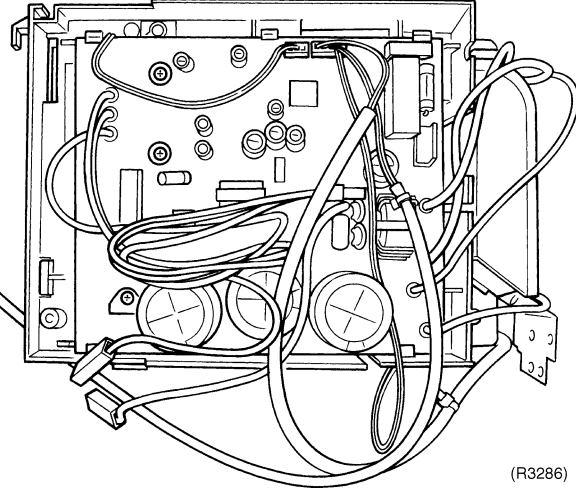
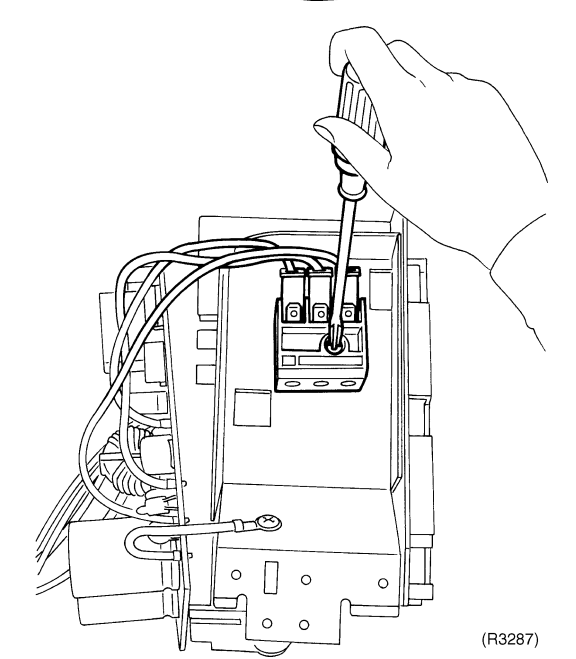
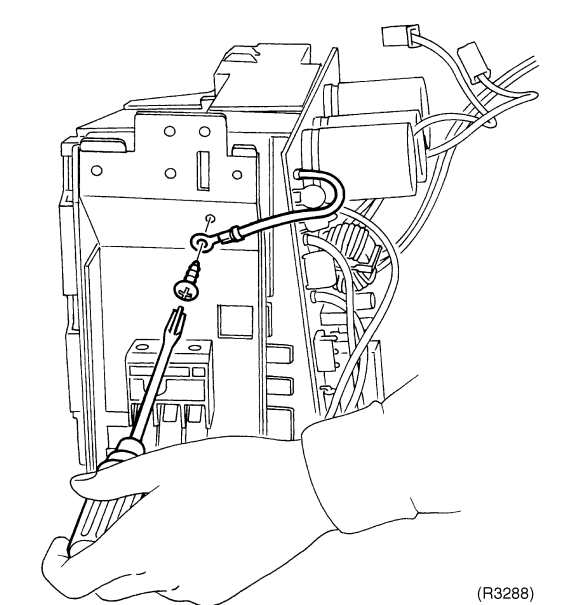

Warning Be sure to wait 10 minutes or more after turning off all power supplies before disassembling work.

Step	Procedure	Points
1. Remove the PCB.		
1 Feature of the PCB	 <p style="text-align: right;">(R3286)</p>	<ul style="list-style-type: none"> ■ You can remove the PCB when you disconnect the read wires on the terminal board without removing the electrical box. ■ PbF (Pb free brazing) is adopted.
2 Loosen the screw on the terminal board.	 <p style="text-align: right;">(R3287)</p>	
3 Release the earth terminal.	 <p style="text-align: right;">(R3288)</p>	

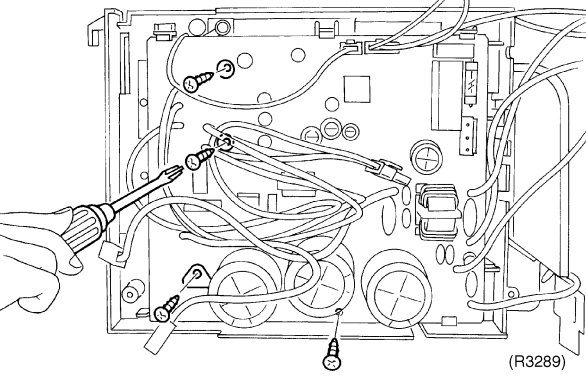
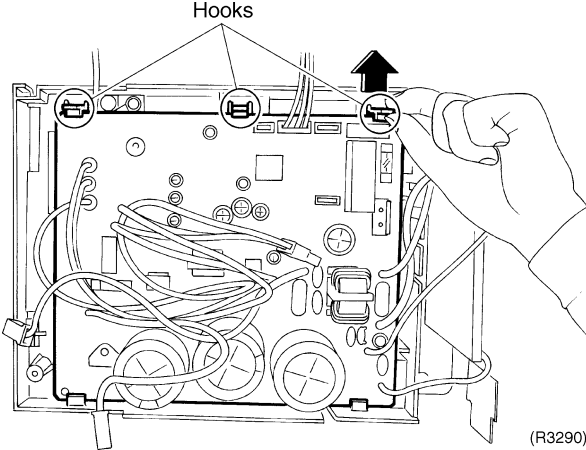
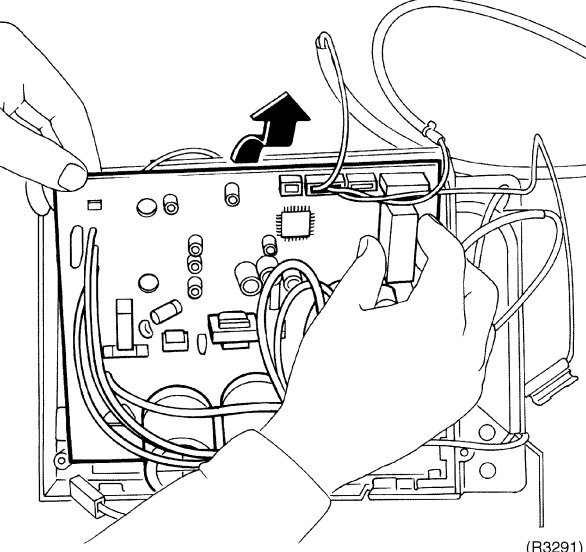
Step	Procedure	Points	Points
4	Loosen the 4 screws.	 <p>(R3289)</p>	
5	Undo the 3 hooks on the upper side.	 <p>Hooks</p> <p>(R3290)</p>	
6	Lift and pull out the PCB.	 <p>(R3291)</p>	

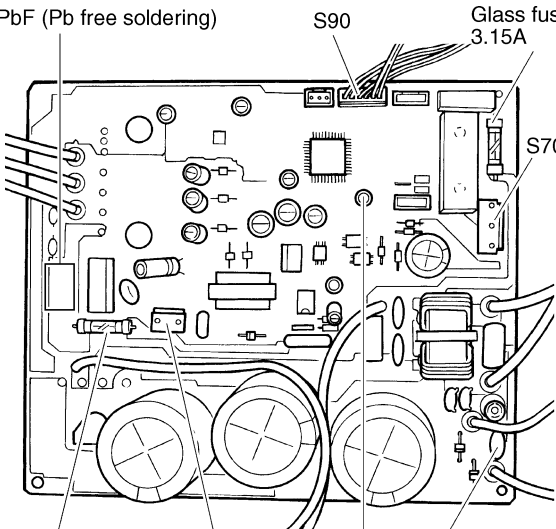
Step	Procedure	Points
<p>7</p> <p>Feature of the PCB S70: fan motor S80: four way valve S90: thermistor (outdoor air, heat exchanger, discharge pipe)</p>	<p>PbF (Pb free soldering)</p>  <p>(R4591)</p>	<p>■ See page 15 for detail.</p>

Part 8 Others

1. Others	160
1.1 Test Run from the Remote Controller	160
1.2 Jumper Settings	161

1. Others

1.1 Test Run from the Remote Controller

For Heat pump

In cooling mode, select the lowest programmable temperature; in heating mode, select the highest programmable temperature.

- Trial operation may be disabled in either mode depending on the room temperature.
- After trial operation is complete, set the temperature to a normal level.
(26°C to 28°C in cooling mode, 20°C to 24°C in heating mode)
- For protection, the system disables restart operation for 3 minutes after it is turned off.

For Cooling Only

Select the lowest programmable temperature.

- Trial operation in cooling mode may be disabled depending on the room temperature.
Use the remote control for trial operation as described below.
- After trial operation is complete, set the temperature to a normal level (26°C to 28°C).
- For protection, the machine disables restart operation for 3 minutes after it is turned off.

Trial Operation and Testing

1. Measure the supply voltage and make sure that it falls in the specified range.
 2. Trial operation should be carried out in either cooling or heating mode.
 3. Carry out the test operation in accordance with the Operation Manual to ensure that all functions and parts, such as louver movement, are working properly.
- The air conditioner requires a small amount of power in its standby mode. If the system is not to be used for some time after installation, shut off the circuit breaker to eliminate unnecessary power consumption.
 - If the circuit breaker trips to shut off the power to the air conditioner, the system will restore the original operation mode when the circuit breaker is opened again.

Trial operation from Remote Controller

- (1) Press ON/OFF button to turn on the system.
- (2) Simultaneously press center of TEMP button and MODE buttons.
- (3) Press MODE button twice.
(“T” will appear on the display to indicate that Trial Operation mode is selected.)
- (4) Trial run mode terminates in approx. 30 minutes and switches into normal mode. To quit a trial operation, press ON/OFF button.

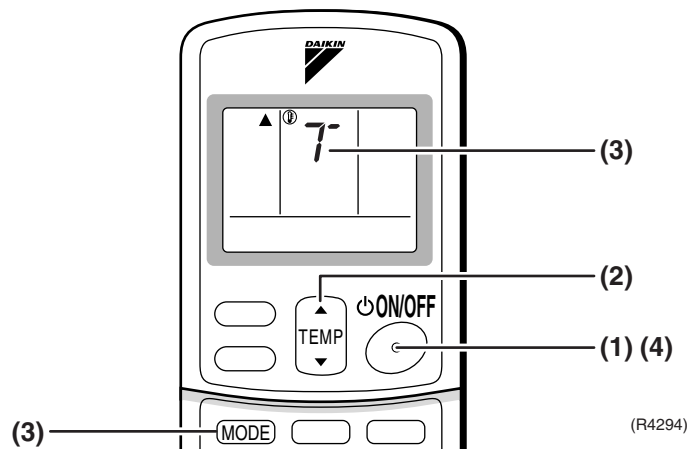

(R4294)

1.2 Jumper Settings

1.2.1 When Two Units are Installed in One Room

When two indoor units are installed in one room, the two wireless remote controllers can be set for different addresses.

How to set the different addresses

■ Control PCB of the indoor unit

- (1) Open the air inlet grille and the screw cover, and remove the 7 screws.
- (2) Release the claws in the 3 places indicated.
- (3) Release the center hook and remove the front panel.
- (4) Release the claws in the 2 places indicated and remove the electric component cover.
- (5) Cut the address jumper **JA** on the control PCB.

■ Wireless remote controller

- (1) Slide the front cover and take it off.
- (2) Cut the address jumper **J4**.

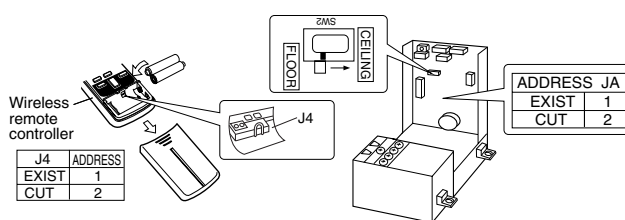

(R4975)

1.2.2 Jumper Setting

Jumper (On indoor control PCB)	Function	When connected (factory set)	When cut
JC	Power failure recovery function	Auto-restart	Unit does not resume operation after recovering from a power failure. Timer ON-OFF settings are cleared.
JB	Fan speed setting when compressor is OFF on thermostat.	Fan speed setting ; Remote controller setting	Fan rpm is set to "0" <Fan stop>

Part 9

Appendix

1. Piping Diagrams.....	164
1.1 Indoor Units.....	164
1.2 Outdoor Units.....	165
2. Wiring Diagrams.....	167
2.1 Indoor Units.....	167
2.2 Outdoor Units.....	167

1. Piping Diagrams

1.1 Indoor Units

FLKS25BVMB, FLKS35BVMB, FLKS25BAVMB, FLKS35BAVMB

FLXS25BVMB, FLXS35BVMB, FLXS25BAVMB, FLXS35BAVMB

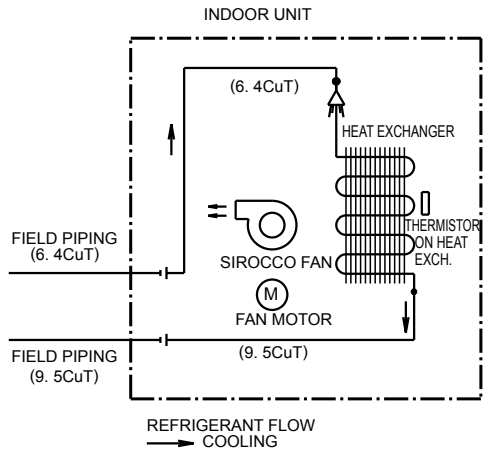

4D034012E

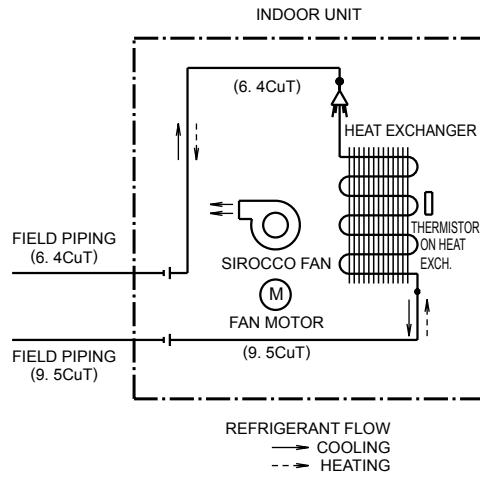

4D048722A

1.2 Outdoor Units

1.2.1 Cooling Only

RKS25DVMB, RKS25D2VMB, RKS25D3VMB

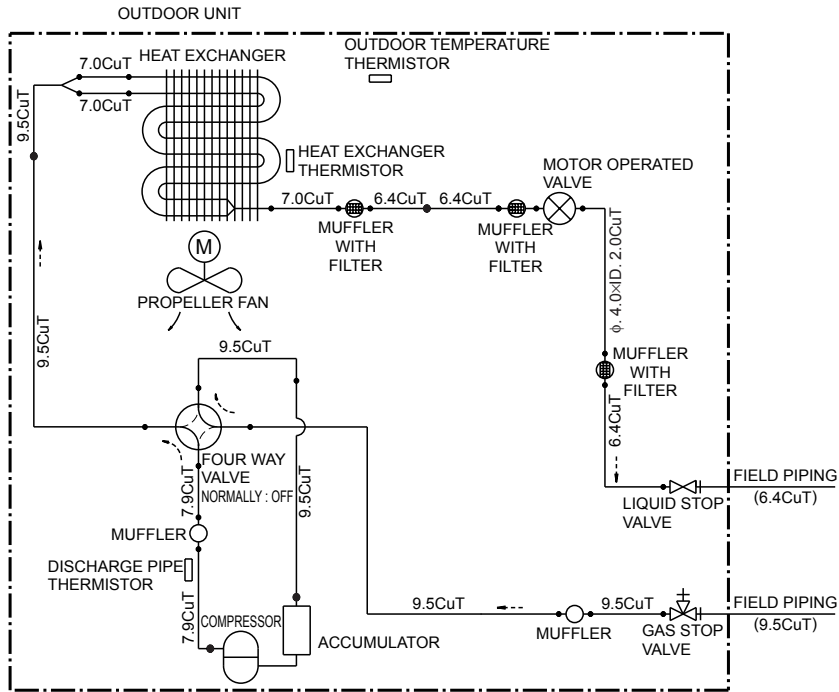

3D047317A

RKS35DVMB, RKS35D2VMB, RKS35D3VMB

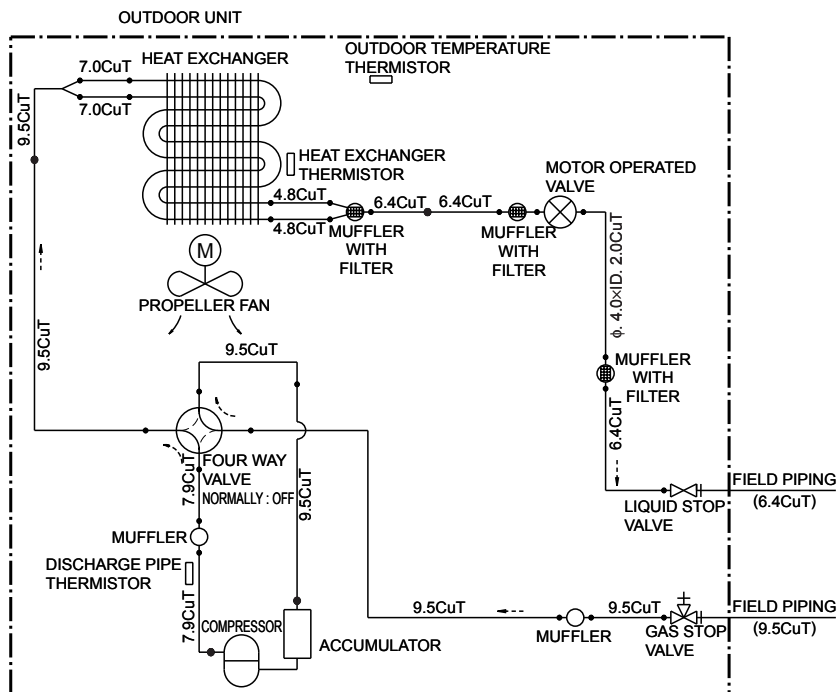

3D047318A

2. Wiring Diagrams

2.1 Indoor Units

FLKS25/35BVMB, FLXS25/35BVMB, FLKS25/35BAVMB, FLXS25/35BAVMB

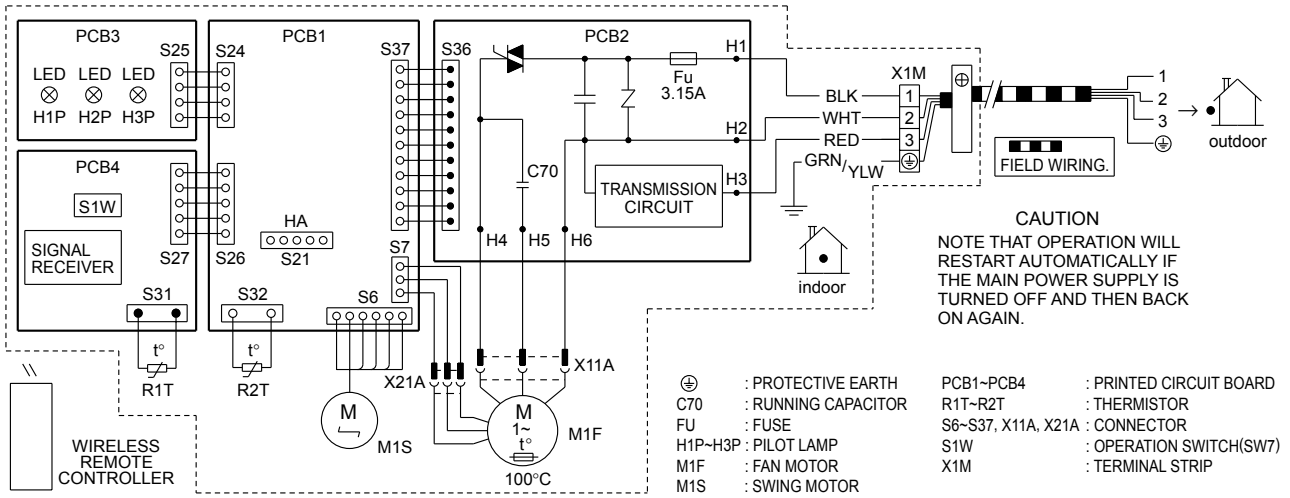

3D033909E

2.2 Outdoor Units

RK(X)S25/35DVMB, RK(X)S25/35D2VMB, RK(X)S25/35D3VMB

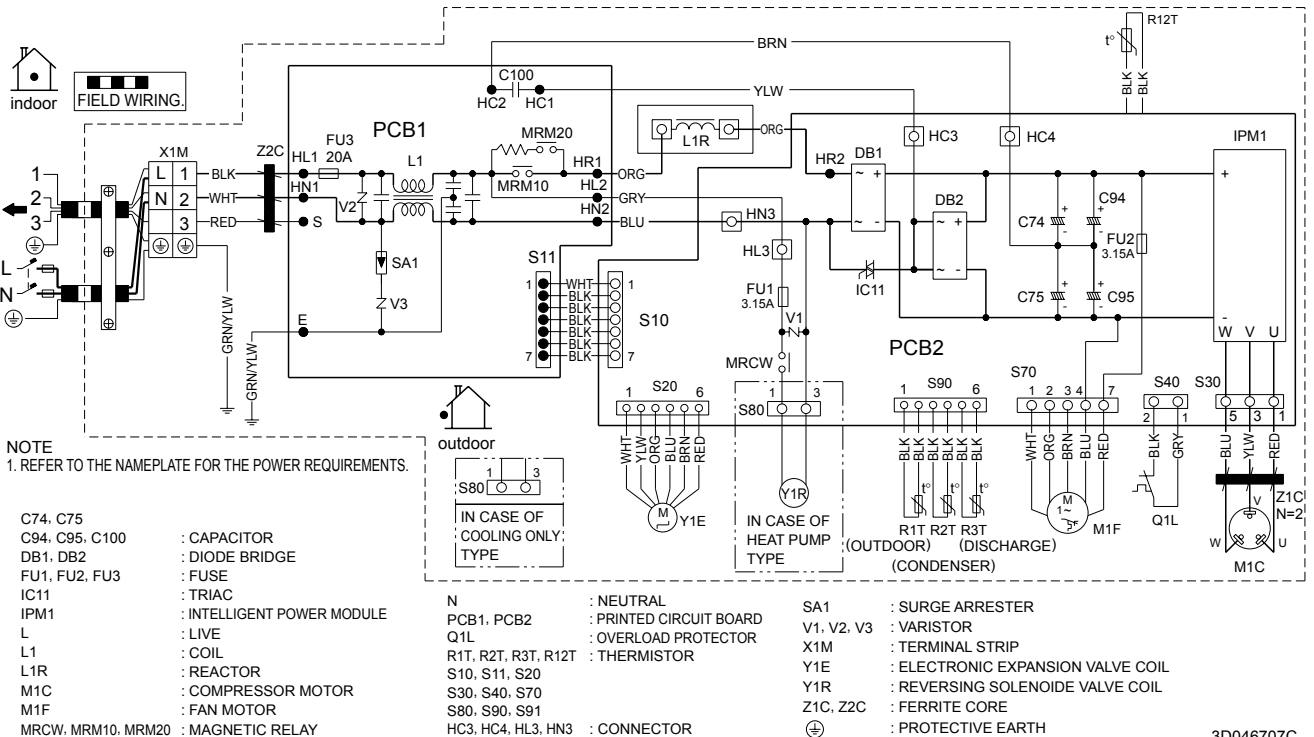

3D046707C

Index

Numerics

00	81
3-minute standby	28, 35

A

A1	82
A5	83
A6	85
address setting jumper	12
adjusting the air flow direction	59
air filter	28, 123
air flow control	21
air purifying filter	28
ARC433A	78
AUTO · DRY · COOL · HEAT · FAN operation	57
automatic operation	23
auto-restart	161
auto-restart function	28
auto-swing	20
auxiliary flexible tube	136

B

bearing fixture	135
bell mouth	141

C

C4	86
C9	86
care and cleaning	67
centralized control	12
check	
discharge pressure check	116
electronic expansion valve check	113
four way valve performance check	114
Hall IC check	119
installation condition check	116
inverter units refrigerant system check	117
outdoor unit fan system check	117
power supply waveforms check	117
power transistor check	118
thermistor resistance check	115
turning speed pulse input on the outdoor unit PCB check	118
check No.04	113
check No.05	114
check No.06	115
check No.07	116
check No.08	116
check No.09	117
check No.10	117
check No.11	117
check No.13	118
check No.15	118
check No.16	119
compressor	153

compressor lock	91
compressor overload	90
compressor protection function	35
compressor system sensor abnormality	99
connectors	12, 14
control PCB (indoor unit)	13, 132
control PCB (outdoor unit)	15

D

DC fan lock	92
DC voltage / current sensor abnormality	101
defrost control	39
diagnosis mode	79
discharge grille	129
discharge pipe	41
discharge pipe control	35
discharge pipe temperature control	42, 96
discharge pipe thermistor	29, 30, 41, 103, 146
discharge pressure check	116
display PCB	13
drain pan	130
drip proof plate	139

E

E1	89
E5	90
E6	91
E7	92
E8	93
EA	94
earth	131
electrical box	133, 145
electrical box cover	131
electrical box temperature rise	104
electronic expansion valve check	113
electronic expansion valve control	40
error codes	
00	81
A1	82
A5	83
A6	85
C4	86
C9	86
E1	89
E5	90
E6	91
E7	92
E8	93
EA	94
F3	96
F6	97
H0	99
H6	100
H8	101
H9	102

J3	102	HL3	14
J6	102	HN3	14
L3	104	HOME LEAVE operation	26, 63
L4	106	horizontal blade	127
L5	108	hot start function	28
P4	102		
U0	110	I	
U2	112	indoor heat exchanger thermistor	29, 30
U4	87	indoor unit PCB abnormality	82
UA	88	input current control	36
error codes and description	81	input over current detection	93
F		installation condition check	116
F3	96	instruction	49
F6	97	insufficient gas	110
facility setting jumper	14, 45	insufficient gas control	43
fan control	38	inverter features	19
fan motor	134, 142	inverter POWERFUL operation	27
fan motor (AC motor) or related abnormality	85	inverter principle	18
fan motor fixing frame	142	inverter units refrigerant system check	117
fan motor fixtures	135		
fan motor, connector	139	J	
fan rotor	134	J3	102
fan rotor covers	134	J4	161
fan speed control	21	J6	102
fan speed setting	12, 161	J8	14
filter PCB	15	JA	12, 161
forced operation mode	44	JB	12, 161
four way valve	151	JC	12, 161
four way valve abnormality	94	jumper settings	161
four way valve operation compensation	34		
four way valve performance check	114	L	
four way valve switching	34	L3	104
four way valve, connector	145	L4	106
freeze-up protection control	37, 83	L5	108
frequency control	18, 32	LED A	14
frequency principle	18	LED1	12
front grille	122	LED2	12
front panel	125, 139	LED3	12
FU1	12, 14	liquid compression protection function 2	38
FU2	14		
FU3	14	M	
function of thermistor	29	mode hierarchy	31
functions	2	mold proof air filter	28
fuse	12, 14		
H		N	
H0	99	names of parts	51
H6	100	night set mode	25
H8	101		
H9	102	O	
HA	12	OL activation	90
Hall IC	21	ON/OFF button on indoor unit	28
Hall IC check	119	opening limit	41
HC3	14	operation lamp	76
HC4	14	outdoor air temperature thermistor	103
heat exchanger	136	outdoor heat exchanger thermistor	29, 30, 103
heat exchanger thermistor	86, 131, 146	outdoor unit fan system check	117
heating peak-cut control	37	outdoor unit PCB abnormality	89
high pressure control	83	OUTDOOR UNIT SILENT operation	62
high pressure control in cooling	97	output over current detection	108
		over current	43, 93, 108
		overload	43, 90

overload protector	14	safety precautions	49
over-voltage detection	112	self-diagnosis digital display	28
P		sensor malfunction detection	43
P4	102	service check function	78
partition plate	147	shelter	138
PCB	155	side panel cover	124
photocatalytic deodorizing filter	28	signal receiver PCB	13
PI control	33	signal receiver unit	128
piping diagrams	164	signal receiving sign	28
piping fixture	136	signal transmission error	87
position sensor abnormality	100	sound blanket	149
power failure recovery function	12, 161	specifications	6
power supply PCB (indoor unit)	13, 133	starting operation control	41
power supply waveforms check	117	stop valve cover	138
power transistor check	118	SW1	12
POWERFUL operation	27, 61	SW2	12
POWERFUL operation mode	44	swing motor	128
preheating operation	34	T	
preparation before operation	54	terminal board	155
pressure equalization control	41	terminal cover	151
printed circuit board (PCB)		terminal strip	132
control PCB (indoor unit)	13, 132	test run	160
control PCB (outdoor unit)	15	thermistor	
display PCB	13	discharge pipe thermistor ...	29, 30, 41, 103, 146
filter PCB	15	function	29
power supply PCB (indoor unit)	13, 133	heat exchanger thermistor	86, 146
signal receiver PCB	13	indoor heat exchanger thermistor	29, 30, 131
problem symptoms and measures	77	outdoor air temperature thermistor	103
programme dry function	22	outdoor heat exchanger thermistor ...	29, 30, 103
propeller fan	140	radiation fin thermistor	103
R		room temperature thermistor	86
radiation fin temperature rise	106	thermistor or related abnormality (indoor unit)	86
radiation fin thermistor	103	thermistor or related abnormality (outdoor unit) ..	102
reactor	147	thermistor resistance check	115
reactor harnesses	145	thermostat control	24
remote controller	78	TIMER operation	65
room temperature thermistor	86	top panel	139
RTH	12	troubleshooting	70, 81
S		troubleshooting with the LED indication	76
S10	14	turning speed pulse input on the outdoor unit PCB	
S11	14	check	118
S20	14	U	
S21	12	U0	110
S24	12	U2	112
S25	12	U4	87
S26	12	UA	88
S27	12	unspecified voltage	88
S30	14	V	
S31	12	V1	12, 14
S32	12	V2	14
S36	12	V3	14
S37	12	varistor	12, 14
S40	14	voltage detection function	44
S6	12	W	
S7	12	wiring diagrams	167
S70	14, 139, 157		
S80	14, 145, 157		
S90	14, 157		

Drawings & Flow Charts

A		
ARC433A	78	
automatic air flow control	21	
automatic operation	23	
auto-swing	20	
C		
compressor lock	91	
compressor protection function	35	
compressor system sensor abnormality	99	
control PCB (indoor unit)	13	
control PCB (outdoor unit)	15	
D		
DC fan lock	92	
DC voltage / current sensor abnormality	101	
defrost control	39	
diagnosis mode	79	
discharge pipe control	35	
discharge pipe temperature control	96	
discharge pressure check	116	
display PCB	13	
E		
electrical box temperature rise	104	
electronic expansion valve check	113	
electronic expansion valve control	40	
F		
facility setting jumper	45	
fan motor (AC motor) or related abnormality	85	
filter PCB	15	
four way valve abnormality	94	
four way valve performance check	114	
freeze-up protection control	37	
freeze-up protection control or high pressure control	83	
frequency control	32	
frequency principle	18	
function of thermistor cooling only model	30	
heat pump model	29	
H		
Hall IC check	119	
heating peak-cut control	37	
high pressure control in cooling	97	
HOME LEAVE operation	26	
I		
indoor unit PCB abnormality	82	
input current control	36	
input over current detection	93	
installation condition check	116	
insufficient gas	110	
insufficient gas control	43	
inverter features	19	
inverter POWERFUL operation	27	
inverter units refrigerant system check	117	
J		
jumper settings	161	
M		
mode hierarchy	31	
N		
night set mode	25	
O		
OL activation (compressor overload)	90	
ON/OFF button on indoor unit	28	
operation lamp, location	76	
outdoor unit fan system check	117	
outdoor unit PCB abnormality	89	
output over current detection	108	
over-voltage detection	112	
P		
pipings diagrams		
FLKS25BAVMB	164	
FLKS25BVMB	164	
FLKS35BAVMB	164	
FLKS35BVMB	164	
FLXS25BAVMB	164	
FLXS25BVMB	164	
FLXS35BAVMB	164	
FLXS35BVMB	164	
RKS25D2VMB	165	
RKS25D3VMB	165	
RKS25DVMB	165	
RKS35D2VMB	165	
RKS35D3VMB	165	
RKS35DVMB	165	
RXS25D2VMB	166	
RXS25D3VMB	166	
RXS25DVMB	166	
RXS35D2VMB	166	
RXS35D3VMB	166	
RXS35DVMB	166	
position sensor abnormality	100	
power supply PCB (indoor unit)	13	
power supply waveforms check	117	
POWERFUL operation	27	
programme dry function	22	
R		
radiation fin temperature rise	106	
remote controller	78	

S

service check function	78
signal receiver PCB	13
signal transmission error (between indoor and outdoor units)	87

T

target discharge pipe temperature control	42
thermistor or related abnormality (indoor unit)	86
thermistor or related abnormality (outdoor unit) ...	102
thermistor resistance check	115
thermostat control	24
trial operation from remote controller	160
turning speed pulse input on the outdoor unit PCB check	118

U

unspecified voltage (between indoor and outdoor units)	88
---	----

W

wiring diagrams	
FLKS25/35BAVMB	167
FLKS25/35BVMB	167
FLXS25/35BAVMB	167
FLXS25/35BVMB	167
RK(X)S25/35D2VMB	167
RK(X)S25/35D3VMB	167
RK(X)S25/35DVMB	167

Warning



- Ask a qualified installer or contractor to install this product. Do not try to install the product yourself. Improper installation can result in water or refrigerant leakage, electrical shock, fire or explosion.
- Use only those parts and accessories supplied or specified by Daikin. Ask a qualified installer or contractor to install those parts and accessories. Use of unauthorized parts and accessories or improper installation of parts and accessories can result in water or refrigerant leakage, electrical shock, fire or explosion.
- Read the User's Manual carefully before using this product. The User's Manual provides important safety instructions and warnings. Be sure to follow these instructions and warnings.

For any inquiries, contact your local distributor.

Cautions on product corrosion

1. Air conditioners should not be installed in areas where corrosive gases, such as acid gas or alkaline gas, are produced.
2. If the outdoor unit is to be installed close to the sea shore, direct exposure to the sea breeze should be avoided and choose an outdoor unit with anti-corrosion treatment.



The air conditioners manufactured by Daikin Industries have received **ISO 9001** certification for quality assurance.

Certificate Number. JMB-0107
JQA-0495
JQA-1452



All Daikin Industries locations and subsidiaries in Japan have received environmental management system standard **ISO 14001** certification.

Daikin Industries, Ltd.
Domestic Group
Certificate Number. EC99J2044

About ISO 14001

ISO 14001 is the standard defined by the International Organization for Standardization (ISO) relating to environmental management systems. Our group has been acknowledged by an internationally accredited compliance organisation as having an appropriate programme of environmental protection procedures and activities to meet the requirements of ISO 14001.

Dealer

DAIKIN INDUSTRIES, LTD.

Head Office:
Umeda Center Bldg., 2-4-12, Nakazaki-Nishi,
Kita-ku, Osaka, 530-8323 Japan

Tokyo Office:
JR Shinagawa East Bldg., 2-18-1, Konan,
Minato-ku, Tokyo, 108-0075 Japan

<http://www.daikin.com/global/>

©All rights reserved