

# technical data



**FLKS-BAVMB**

**Flexi Type,  
Inverter Controlled Unit**

air conditioning systems

Split  
Sky Air

# TABLE OF CONTENTS

## FLKS-BAVMB

1	Features .....	2
2	Specifications .....	3
	For indoor units only .....	3
	Technical Specifications .....	3
	Electrical Specifications .....	4
3	Options .....	5
4	Control systems .....	6
5	Dimensional drawing & centre of gravity .....	7
	Dimensional drawing .....	7
	Centre of gravity .....	8
6	Piping diagram .....	9
7	Wiring diagram .....	10
	Wiring diagram .....	10
8	Sound data .....	11
	Sound level data .....	11
	Sound pressure spectrum .....	12
9	Installation .....	13
	Installation method .....	13

# 1 Features

- Slim&smart
- Lightweight but sturdy design
- Can fit on either ceiling or lower wall. Its low height enables it to fit beneath a window
- The home leave operation saves energy during absence
- Powerful mode can be selected for rapid cooling
- Auto-swing function ensures efficient air and temperature distribution.
- Air purification filter: deodorises the air and helps to prevent bacterial and viral propagation
- The photocatalytic deodorising air filter: powerfully decomposes cigarette and pet odours, removes house dust and pollen and deactivates bacteria and viruses
- Washable front panel
- Indoor unit silent operation: "Silent" button on the remote control lowers the operation sound of the indoor unit by 3dB(A) (only if connected to a DC inverter controlled outdoor unit)
- Easy to install
- Up to 4 indoor units can be connected to 1 Multi outdoor unit. All indoor units are individually controllable with remote control and do not need to be installed in the same room or at the same time. They operate simultaneously within the same cooling m
- Daikin remote controls give you easy control at your fingertips.
- The remote control has a 24-hour timer
- The indoor unit also has a start/stop button mounted on the front panel
- Up to 5 indoor units can be operated from a single centralised control
- Purpose-designed holder provided for your remote control

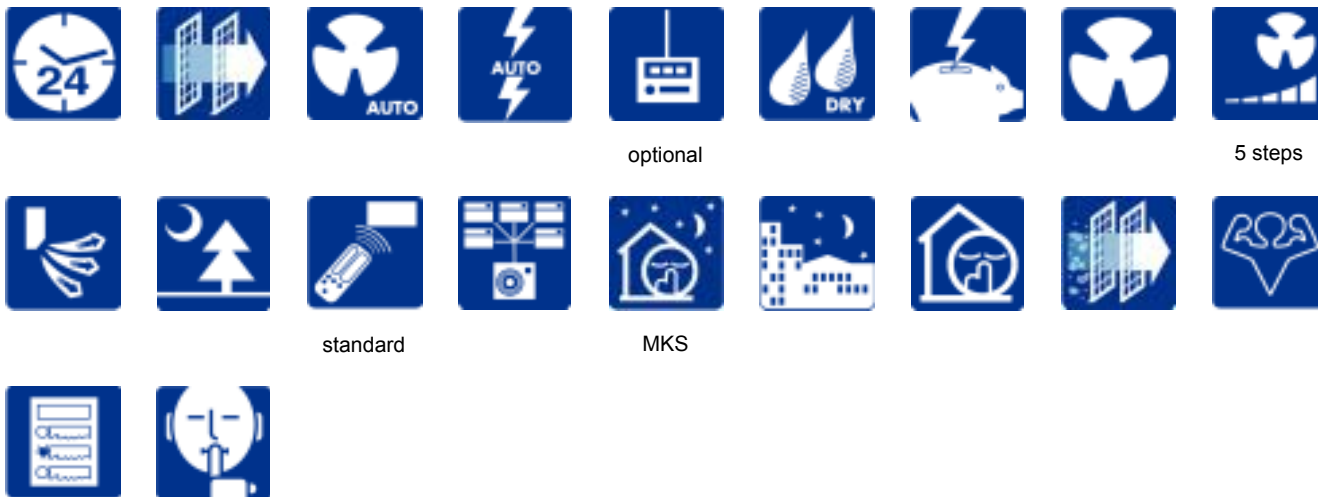

1

## 2 Specifications

2-1 FOR INDOOR UNITS ONLY			FLKS25BAVMB	FLKS35BAVMB	FLKS50BAVMB	FLKS60BAVMB
Nominal Input	Cooling	kW	0.074	0.078	0.096	0.098

2-2 TECHNICAL SPECIFICATIONS				FLKS25BAVMB	FLKS35BAVMB	FLKS50BAVMB	FLKS60BAVMB	
Casing	Colour			Almond white				
Dimensions	Packing	Height	mm	566	566	566	566	
		Width	mm	1100	1100	1100	1100	
		Depth	mm	280	280	280	280	
	Unit	Height	mm	490	490	490	490	
		Width	mm	1050	1050	1050	1050	
		Depth	mm	200	200	200	200	
Weight	Unit		kg	16.0	16.0	17.0	17.0	
	Packed Unit		kg	22.0	22.0	24.0	24.0	
Heat Exchanger	Dimensions	Length	mm	840	840	840	840	
		Nr of Rows			2	2	3	3
		Fin Pitch	mm	1.75	1.75	1.50	1.50	
		Nr of Stages			8	8	10	10
	Tube type		Hi-XA (7)					
Fin		Type	ML fin (Multi louver)					
Fan	Type			Sirocco fan				
	Quantity			1	1	1	1	
Air Flow Rate	Cooling	High	m³/min	7.60	8.60	11.40	12.00	
		Medium	m³/min	6.80	7.60	10.00	10.70	
		Low	m³/min	6.00	6.6	8.50	9.30	
		Silent Operation	m³/min	5.2	5.6	7.5	8.3	
Fan	Motor	Quantity		1	1	1	1	
		Model		KFP-220-34-4A				
		Number of steps		5 steps, silent and auto				
Motor	Speed (cooling)	High	rpm	820	920	1380	1380	
		Medium	rpm	740	820	1240	1240	
		Low	rpm	660	720	1100	1100	
		Silent Operation	rpm	580	620	1000	1000	
Fan	Motor	Output (high)	W	34	34	34	34	
Cooling	Sound Power	High	dBA	53.0	54.0	63.0	64.0	
		Low	dBA	31.0	32.0	39.0	41.0	
	Sound Pressure	High	dBA	37.0	38.0	47.0	48.0	
		Medium	dBA	34.0	35.0	43.0	45.0	
		Silent Operation	dBA	28.0	29.0	36.0	39.0	
Refrigerant	Type			R-410A				
Piping connections	Liquid (OD)	Diameter (OD)	mm	6.4	6.4	6.35	6.35	
		Gas	Diameter (OD)	mm	9.5	9.5	12.7	12.7
	Drain	Diameter (OD)	mm	18	18	18	18	
		Heat Insulation			Both liquid and gas pipes			
Air Filter				Removable/washable/Mildew proof				
Air direction control				Left, right, up and downwards				
Temperature control				Microcomputer control				

## 2 Specifications

2-2 TECHNICAL SPECIFICATIONS			FLKS25BAVMB	FLKS35BAVMB	FLKS50BAVMB	FLKS60BAVMB
Standard Accessories	Item		Installation and operation manual			
	Quantity		1	1	1	1
	Item		Infrared remote control			
	Quantity		1	1	1	1
	Item		Batteries			
	Quantity		2	2	2	2
	Item		Remote control holder			
	Quantity		1	1	1	1
	Item		Air purification filter			
	Quantity		1	1	1	1
	Item		Heat insulation tube (refrigerant pipe)	Heat insulation tube (refrigerant pipe)	Heat insulation tube (refrigerant pipe)	Heat insulation tube (refrigerant pipe)
	Quantity		1	1	2	2
	Item		Mounting plate			
	Quantity		1	1	1	1
	Item		Side cover			
	Quantity		2	2	2	2
	Item		Binding band			
Quantity		4	4	4	4	
Item		Photocatalytic deodorizing filter				
Quantity		1	1	1	1	
Item				Extension auxiliary pipe	Extension auxiliary pipe	
Quantity				2	2	
Notes			Sound values are measured in an anechoic room.			
			Sound pressure level is a relative value, depending on the distance and acoustic environment. For more details, please refer to sound level drawings of this chapter.			
			The sound power level is an absolute value indicating the power which a sound source generates.			

2-3 ELECTRICAL SPECIFICATIONS				FLKS25BAVMB	FLKS35BAVMB	FLKS50BAVMB	FLKS60BAVMB
Power Supply	Name			VM			
	Phase			1	1	1	1
	Frequency		Hz	50/60			
	Voltage		V	220-240/220-230			
Current	Nominal running current (RLA)	Cooling	A	0.340	0.36	0.450	0.450
Wiring connections	For Power Supply	Quantity		3	3	3	3
		Remark		4 for interunit wiring(included earth wiring)			
Voltage range	Minimum			-10%			
	Maximum			+10%			
Power Supply Intake				Outdoor unit only			

### 3 Options

FLK/XS-B		25	35	50	60
Wiring adapter for time clock / remote control (1)	Normal open contact	KRP413A1S			
	Normal open pulse contact	KRP413A1S			
Centralised control board	1 up to 5 rooms (2)	KRC72			
Central remote control		DCS302C51			
Unified ON/OFF control		DCS301B51			
Schedule timer		DST301B51			
Interface adapter (3)		KRP928A2S			
Photocatalytic deodorising filter, with frame		KAZ917A41			
Photocatalytic deodorising filter, without frame		KAZ917A42			
Air purification filter with frame		KAF925B41			
Air purification filter without frame		KAF925B42			
Anti-theft protection for remote control		KKF917AA4			

(1) Wiring adapter is also required for each indoor unit.  
 (2) Wiring adapter supplied by Daikin. Time clock and other devices: field supply.  
 (3) For DIII-NET adapter

## 4 Control systems

FLK/XS -B

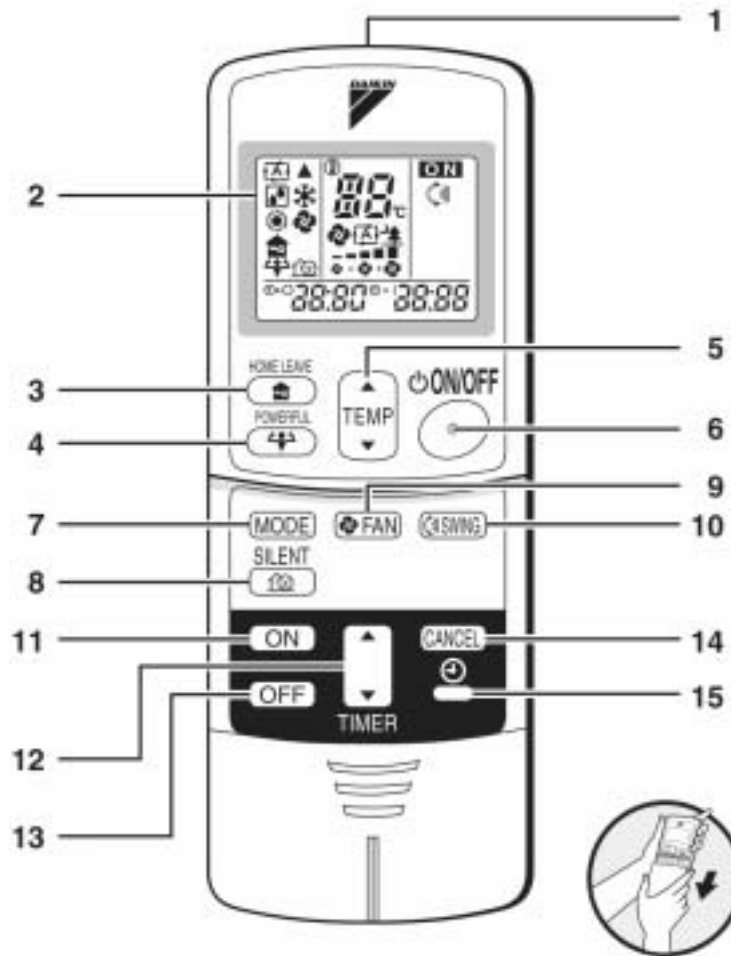

<ARC433A5, A6>

- |   |  |
|---|--|
| <p>1 <b>Signal transmitter:</b><br/>• It sends signals to the indoor unit.</p> <p>2 <b>Display:</b><br/>• It displays the current settings. (In this illustration, each section is shown with all its displays ON for the purpose of explanation.)</p> <p>3 <b>HOME LEAVE button:</b><br/>for HOME LEAVE operation</p> <p>4 <b>POWERFUL button:</b><br/>for POWERFUL operation</p> <p>5 <b>TEMPERATURE adjustment buttons:</b><br/>• It changes the temperature setting</p> <p>6 <b>ON/OFF button:</b><br/>• Press this button once to start operation. Press once again to stop it.</p> <p>7 <b>MODE selector button:</b><br/>• It selects the operation mode<br/>(Auto  / Dry  / Cool  / Heat  / Fan </p> | <p>8 <b>OUTDOOR UNIT SILENT button:</b><br/>SILENT operation</p> <p>9 <b>FAN setting button:</b><br/>• It selects the air flow rate setting.</p> <p>10 <b>SWING button</b></p> <p>11 <b>ON TIMER button</b></p> <p>12 <b>OFF TIMER button</b></p> <p>13 <b>TIMER setting button:</b><br/>• It changes the time setting</p> <p>14 <b>TIMER CANCEL button:</b><br/>It cancels the timer setting.</p> <p>15 <b>CLOCK button</b></p> |
|---|--|

# 5 Dimensional drawing & centre of gravity

## 5 - 1 Dimensional drawing

**FLK/XS25-35-50-60B**  
**Floor level installation**  
 The mark (→) shows piping direction

**unit (mm)**

Required space (for performance and maintenance)

Air flow (indoor)

200MIN (space for maintenance)      200MIN (space for performance)

50MIN (space for performance)

- Liquid pipe (6.4CuT)
- Gas pipe (A CuT)
- Drain hose (ID  $\phi$  14 - OD  $\phi$  18)

	A
FLX(K)S25B	$\phi$ 9.5
FLX(K)S35B	$\phi$ 9.5
FLX(K)S50B	$\phi$ 12.7
FLX(K)S60B	$\phi$ 12.7

Wall hole for refrigerant piping  $\phi$  80 hole

Wall hole for embedded piping  $\phi$  80 hole

Location of wall holes

50MIN (space for maintenance)

3D033695C

**FLK/XS25-35-50-60B**  
**Ceiling suspended installation**  
 The mark (→) shows piping direction

**unit (mm)**

Required service space (ceiling suspended) (for performance and maintenance)

Air flow (indoor)

200MIN (space for maintenance)      200MIN (space for performance)

- Liquid pipe (6.4CuT)
- Gas pipe (A CuT)

	A
FLX(K)S25B	$\phi$ 9.5
FLX(K)S35B	$\phi$ 9.5
FLX(K)S50B	$\phi$ 12.7
FLX(K)S60B	$\phi$ 12.7

Wall hole for refrigerant  $\phi$  65 hole

$\phi$  40 drain hose hole

- Drain hose (ID  $\phi$  14 - OD  $\phi$  18)

Standard locations of wall holes

Wall hole for embedded piping  $\phi$  65 hole

50 min (space for maintenance)

Location of suspension bolts

3D033694B



## 5 Dimensional drawing & centre of gravity

### 5 - 2 Centre of gravity

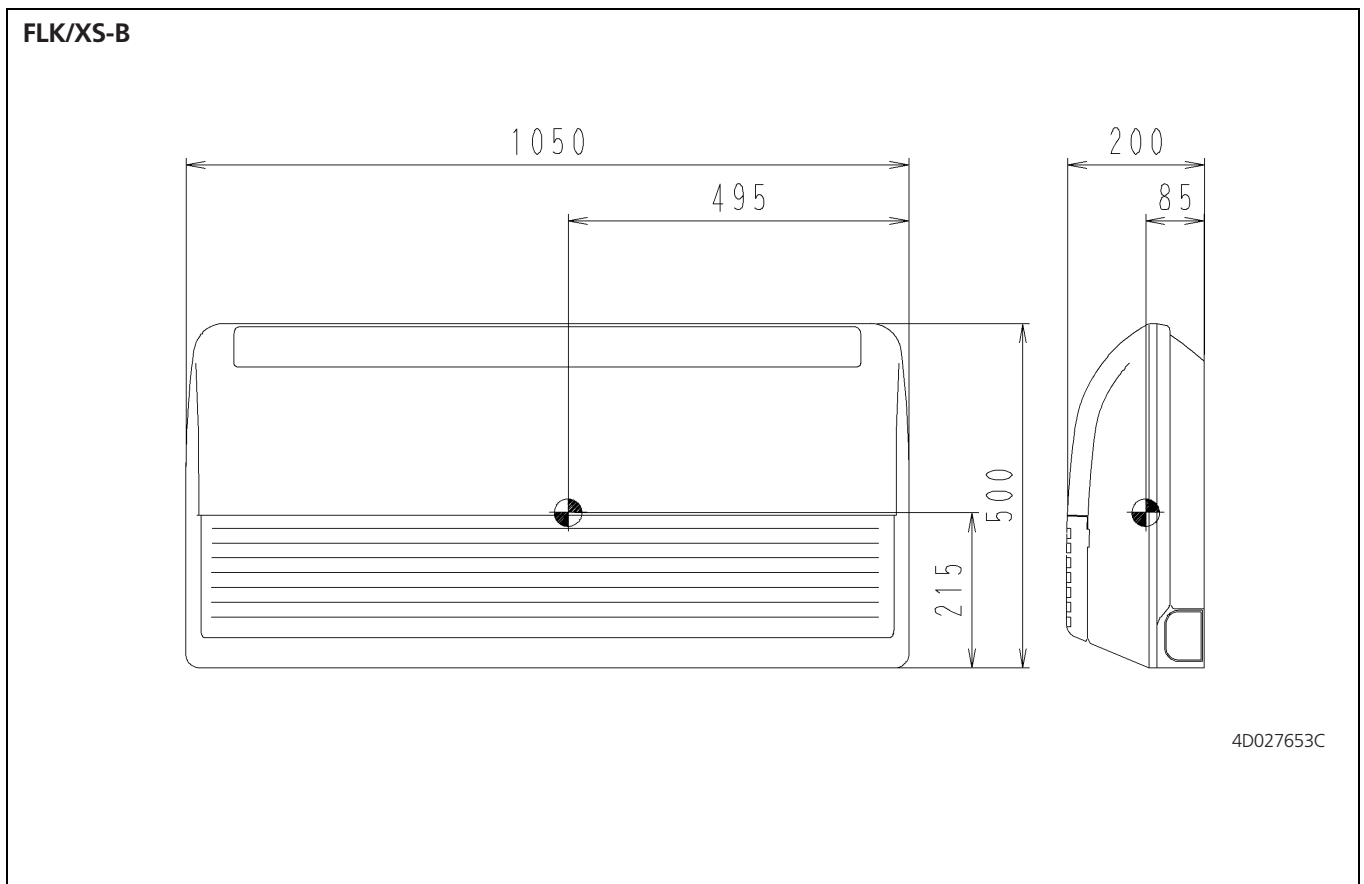

# 6 Piping diagram

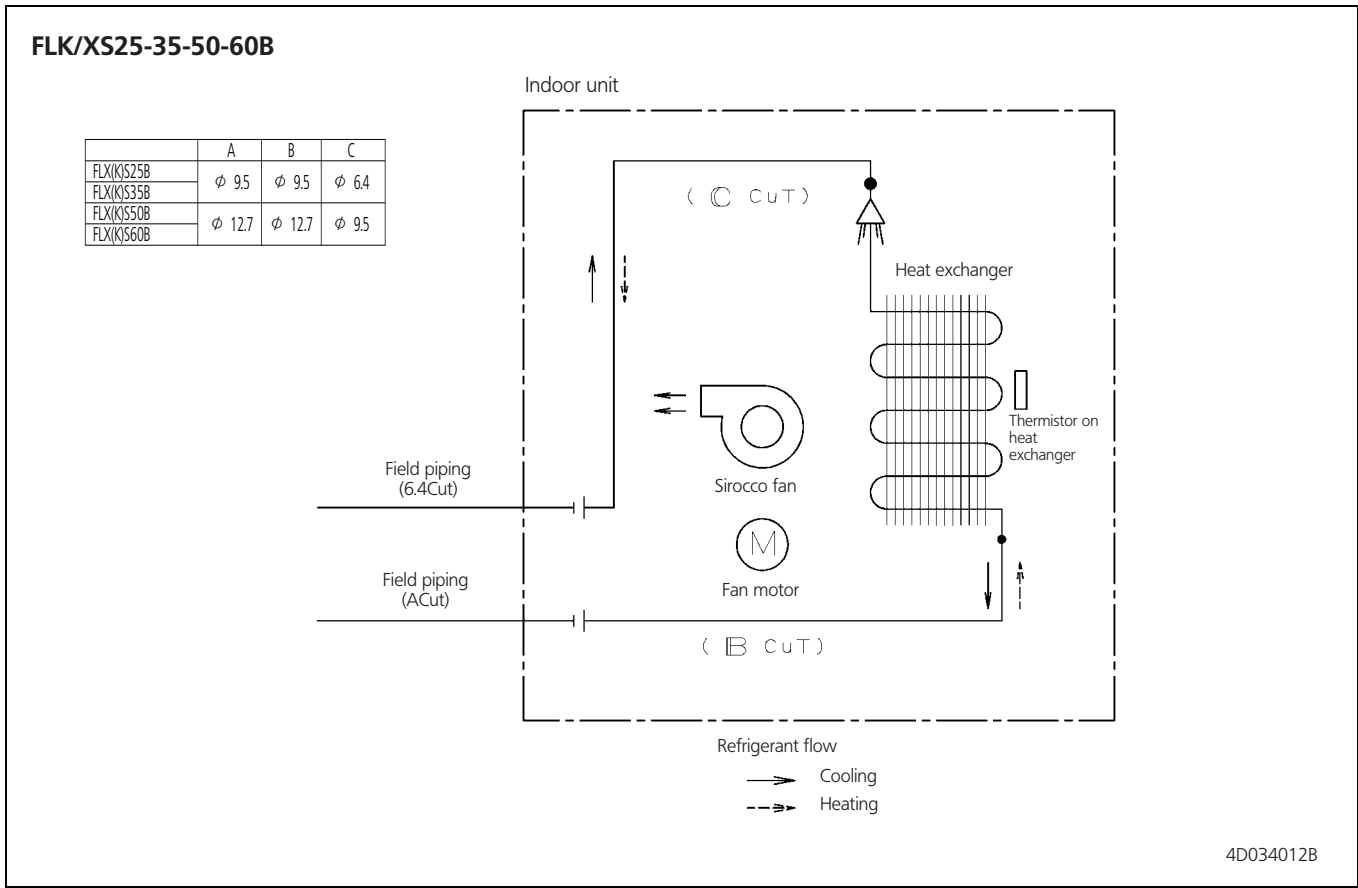

# 7 Wiring diagram

## 7 - 1 Wiring diagram

FLK/XS25-35-50-60B

**Caution:**

Notice that operation will restart automatically when the main power supply is turned off and then turned on again.

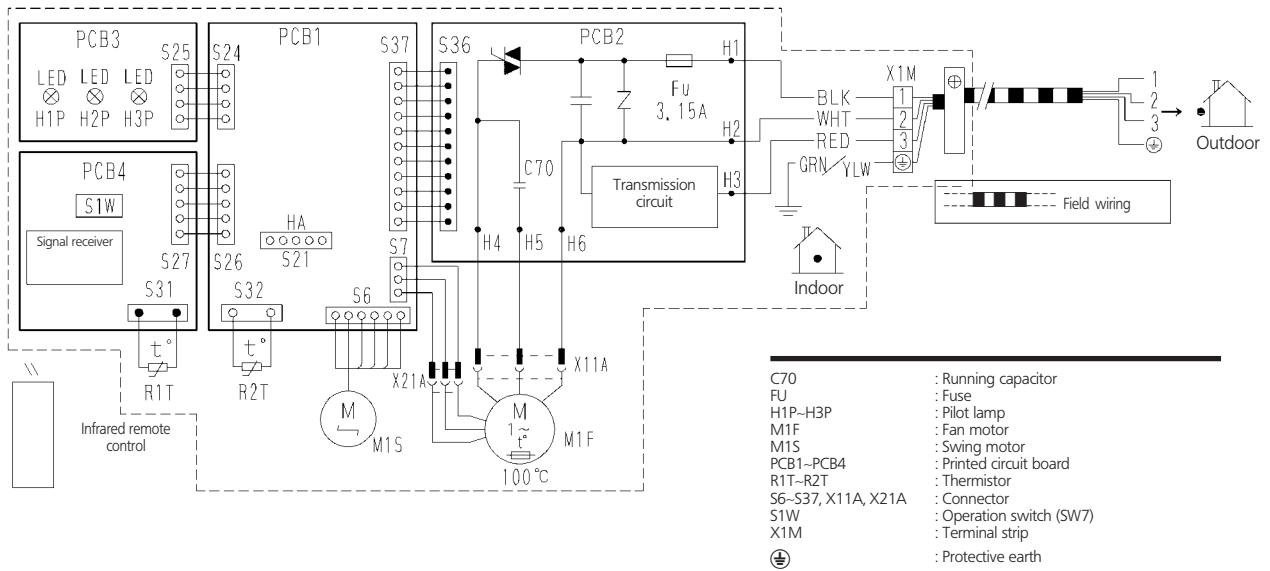

3D033909B

## 8 Sound data

### 8 - 1 Sound level data

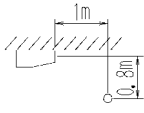
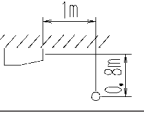
Cooling only					
Model	Sound pressure level			Measuring location	Sound power level (Cooling)
	230V, 50Hz				
	Cooling				
	H	L	SL		
FLKS25B	37	31	28	Location of microphone 	53
FLKS35B	38	32	29		54
FLKS50B	47	39	36		63
FLKS60B	48	41	39		64
Heat pump					
Model	Sound pressure level			Measuring location	Sound power level (Cooling/Heating)
	230V, 50Hz				
	Cooling/Heating				
	H	L	SL		
FLXS25B	37/37	31/31	28/29	Location of microphone 	53/*
FLXS35B	38/39	32/33	29/30		54/*
FLXS50B	47/46	39/35	36/33		63/*
FLXS60B	48/47	41/37	39/34		64/63
* Sound power levels were not available at time of publication					

# 8 Sound data

## 8 - 2 Sound pressure spectrum

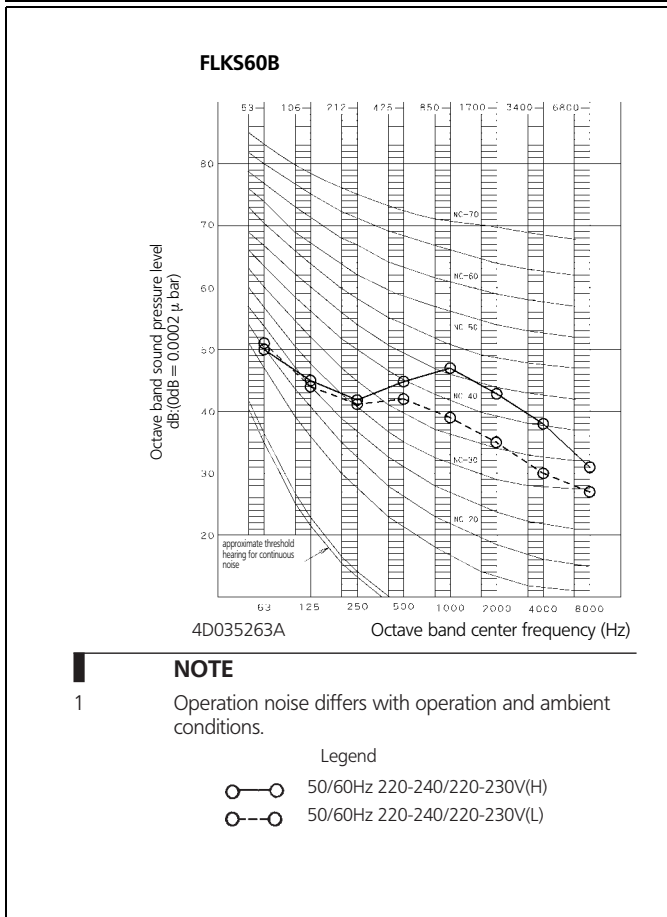
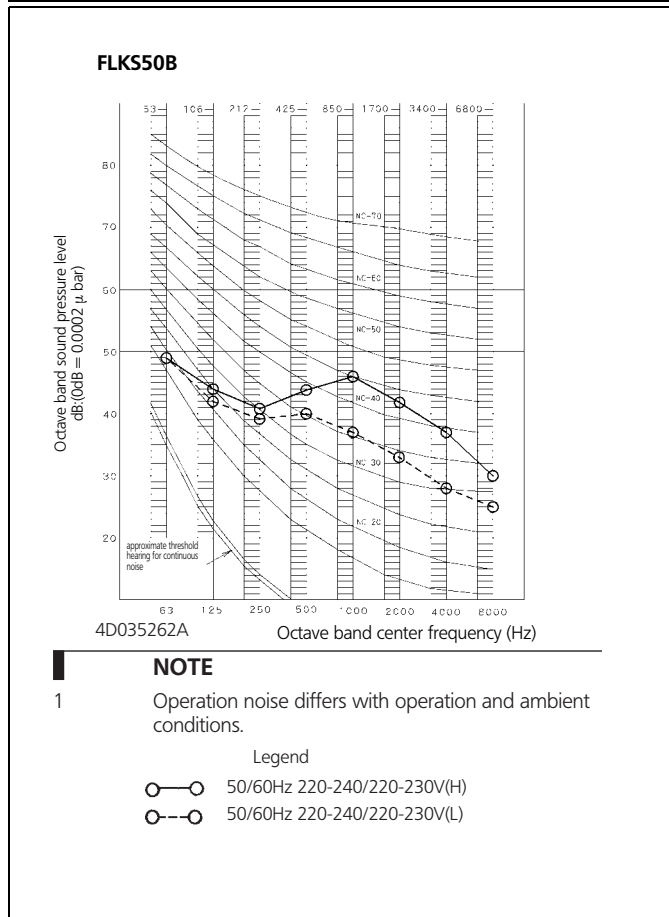
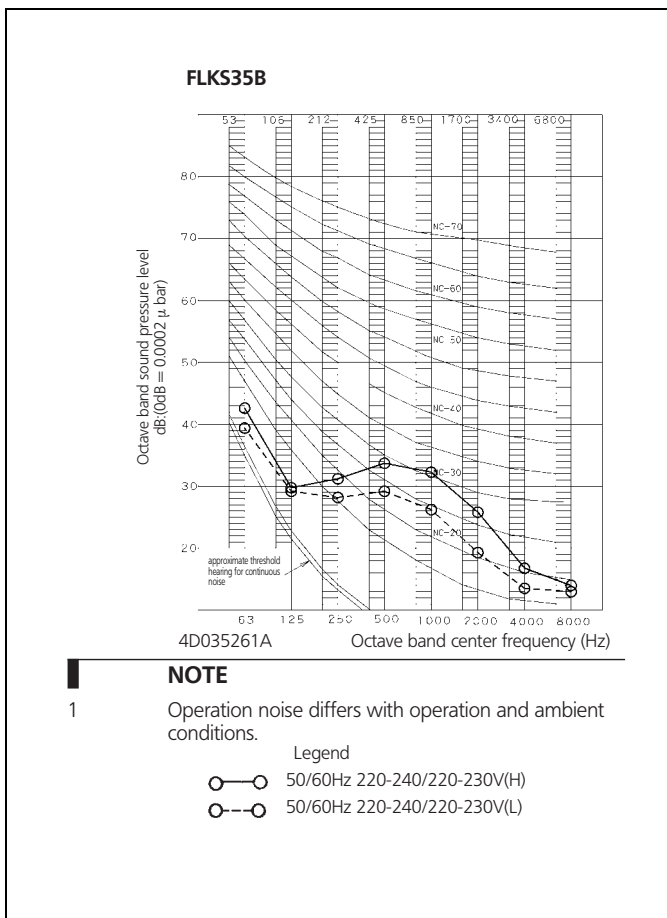
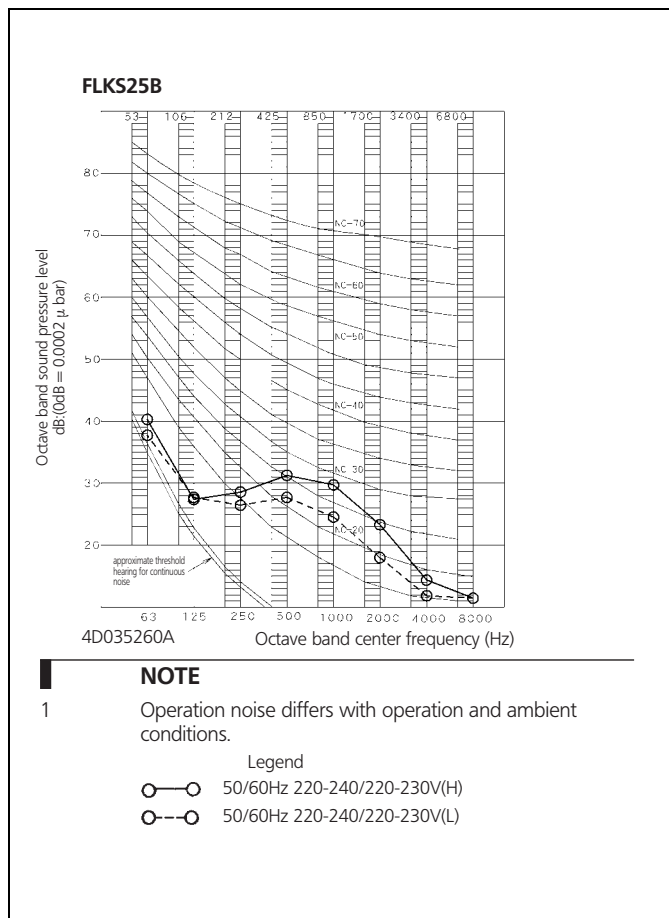

# 9 Installation

## 9 - 1 Installation method

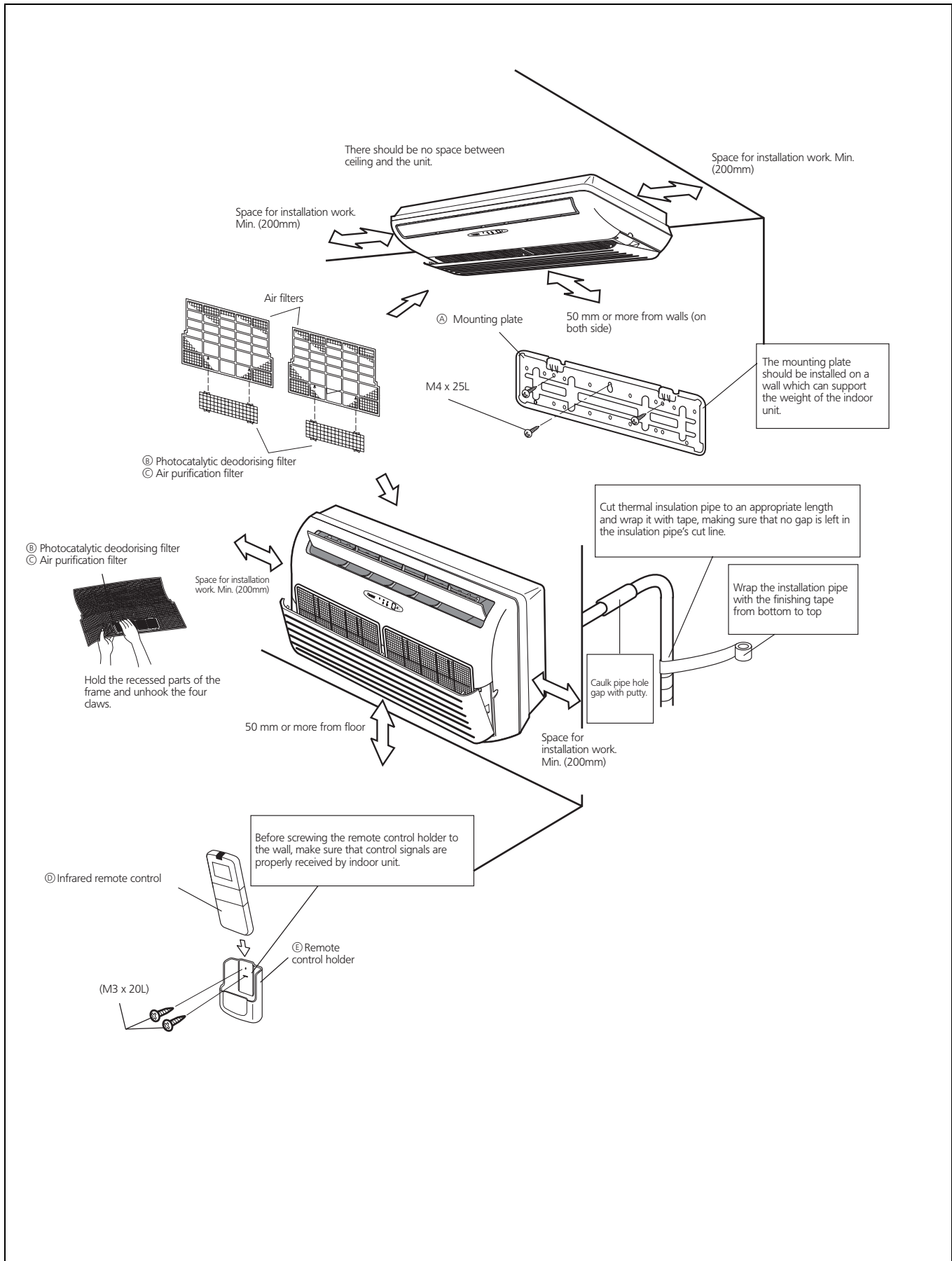

# 9 Installation

## 9 - 1 Installation method

### Ceiling mounting

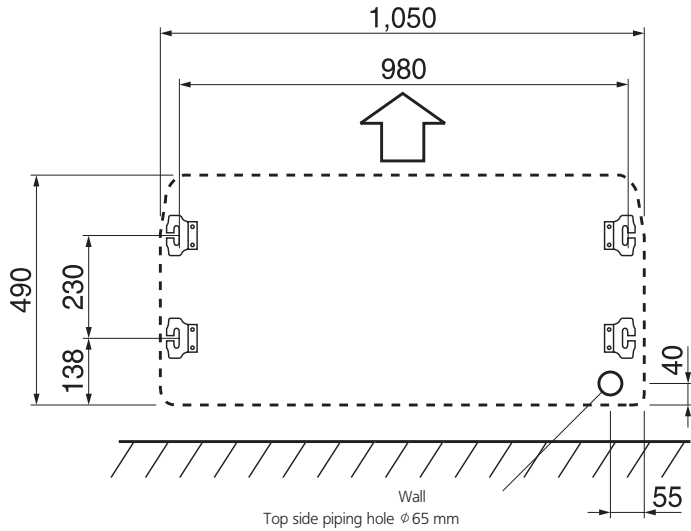
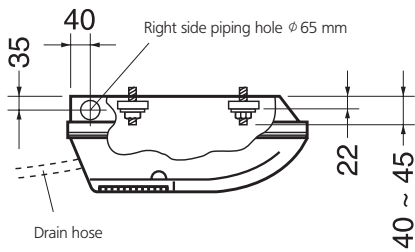
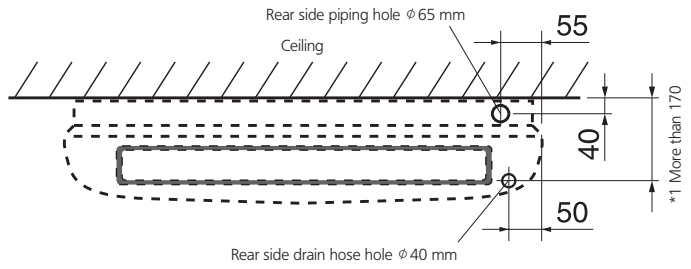
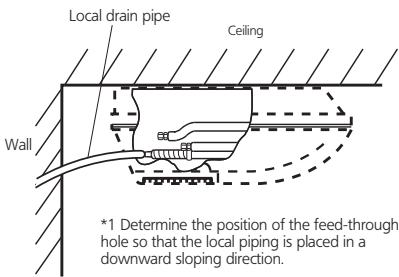

### Wall mounting

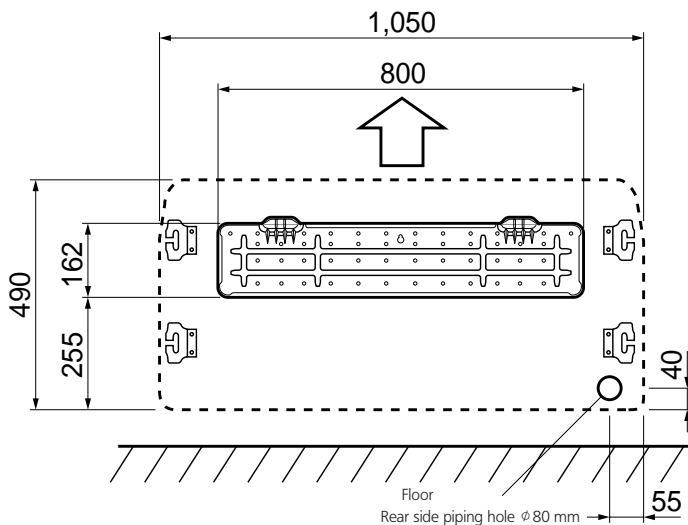
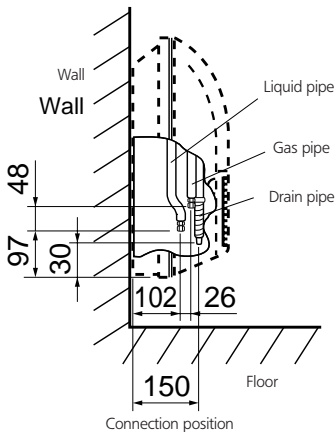
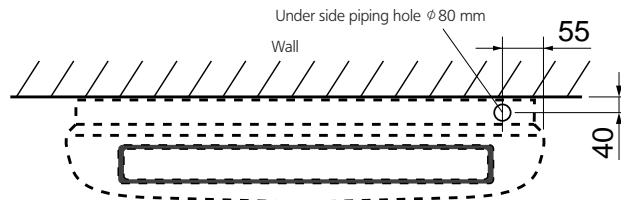
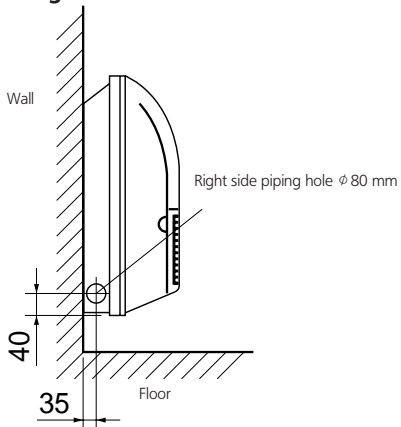

# Split - Sky Air

The present publication is drawn up by way of information only and does not constitute an offer binding upon Daikin Europe N.V.. Daikin Europe N.V. has compiled the content of this publication to the best of its knowledge. No express or implied warranty is given for the completeness, accuracy, reliability or fitness for particular purpose of its content and the products and services presented therein. Specifications are subject to change without prior notice. Daikin Europe N.V. explicitly rejects any liability for any direct or indirect damage, in the broadest sense, arising from or related to the use and/or interpretation of this publication. All content is copyrighted by Daikin Europe N.V..



ISO14001 assures an effective environmental management system in order to help protect human health and the environment from the potential impact of our activities, products and services and to assist in maintaining and improving the quality of the environment.



Daikin units comply with the European regulations that guarantee the safety of the product.



Daikin Europe N.V. is approved by LRQA for its Quality Management System in accordance with the ISO9001 standard. ISO9001 pertains to quality assurance regarding design, development, manufacturing as well as to services related to the product.



Daikin Europe N.V. is participating in the EUROVENT Certification Programme. Products are as listed in the EUROVENT Directory of Certified Products.

## **DAIKIN EUROPE N.V.**

Zandvoordestraat 300  
B-8400 Ostend - Belgium  
[www.daikineurope.com](http://www.daikineurope.com)

