

Service Manual

Inverter Pair Wall Mounted Type L-Series



[Applied Models]

- Inverter Pair : Heat Pump

Inverter Pair Wall Mounted Type L-Series

●Heat Pump

Indoor Unit

FTXG20LV1BW
FTXG20LV1BS
FTXG25LV1BW
FTXG25LV1BS
FTXG35LV1BW
FTXG35LV1BS
FTXG50LV1BW
FTXG50LV1BS

Outdoor Unit

RXG20L2V1B
RXG25L2V1B
RXG35L2V1B
RXG50L2V1B

1. Safety Cautions.....	V
1.1 Warnings and Cautions Regarding Safety of Workers.....	v
1.2 Warnings and Cautions Regarding Safety of Users.....	vii
2. Used Icons	x
Part 1 List of Functions	1
1. Functions.....	2
Part 2 Specifications	3
1. Specifications	4
Part 3 Printed Circuit Board Connector Wiring Diagram	8
1. Indoor Unit.....	9
2. Outdoor Unit.....	11
2.1 20/25/35 Class	11
2.2 50 Class	13
Part 4 Function and Control.....	15
1. Main Functions.....	16
1.1 Temperature Control	16
1.2 Frequency Principle.....	16
1.3 Operation Starting Control.....	18
1.4 Airflow Direction Control.....	19
1.5 Fan Speed Control for Indoor Unit	20
1.6 Program Dry Operation	21
1.7 Automatic Operation.....	22
1.8 Thermostat Control.....	23
1.9 NIGHT SET Mode	24
1.10 ECONO Operation	24
1.11 2-Area INTELLIGENT EYE Operation	25
1.12 Inverter POWERFUL Operation	27
1.13 Multi-Monitor Lamp / TIMER Lamp	27
1.14 Clock Setting	28
1.15 WEEKLY TIMER Operation	29
1.16 Other Functions.....	35
2. Function of Thermistor	36
3. Control Specification	37
3.1 Mode Hierarchy	37
3.2 Frequency Control.....	37
3.3 Controls at Mode Changing / Start-up.....	39
3.4 Discharge Pipe Temperature Control.....	40
3.5 Input Current Control.....	41
3.6 Freeze-up Protection Control	42
3.7 Heating Peak-cut Control	42
3.8 Outdoor Fan Control.....	43
3.9 Liquid Compression Protection Function.....	43
3.10 Defrost Control	44
3.11 Electronic Expansion Valve Control	45
3.12 Malfunctions	48

Part 5 Remote Controller	49
1. Remote controller.....	50
Part 6 Service Diagnosis.....	52
1. General Problem Symptoms and Check Items	53
2. Troubleshooting with LED	54
2.1 Indoor Unit.....	54
2.2 Outdoor Unit.....	54
3. Service Diagnosis	55
4. Troubleshooting	58
4.1 Error Codes and Description	58
4.2 Indoor Unit PCB Abnormality	59
4.3 Freeze-up Protection Control / Heating Peak-cut Control	60
4.4 Fan Motor (DC Motor) or Related Abnormality.....	61
4.5 Thermistor or Related Abnormality (Indoor Unit).....	63
4.6 Front Panel Open / Close Fault.....	64
4.7 Refrigerant Shortage	65
4.8 Low-voltage Detection or Over-voltage Detection.....	67
4.9 Signal Transmission Error (Between Indoor Unit and Outdoor Unit).....	69
4.10 Unspecified Voltage (Between Indoor Unit and Outdoor Unit)	71
4.11 Outdoor Unit PCB Abnormality.....	72
4.12 OL Activation (Compressor Overload)	73
4.13 Compressor Lock	75
4.14 DC Fan Lock	76
4.15 Input Overcurrent Detection	77
4.16 Four Way Valve Abnormality	78
4.17 Discharge Pipe Temperature Control.....	80
4.18 High Pressure Control in Cooling	81
4.19 Compressor System Sensor Abnormality	82
4.20 Position Sensor Abnormality	83
4.21 DC Voltage / Current Sensor Abnormality (20/25/35 Class Only).....	85
4.22 Thermistor or Related Abnormality (Outdoor Unit).....	86
4.23 Electrical Box Temperature Rise	88
4.24 Radiation Fin Temperature Rise	89
4.25 Output Overcurrent Detection	91
5. Check	93
5.1 Thermistor Resistance Check	93
5.2 Fan Motor Connector Output Check	94
5.3 Power Supply Waveforms Check.....	94
5.4 Electronic Expansion Valve Check.....	94
5.5 Four Way Valve Performance Check	95
5.6 Inverter Unit Refrigerant System Check.....	95
5.7 Inverter Analyzer Check	96
5.8 Rotation Pulse Check on the Outdoor Unit PCB	97
5.9 Installation Condition Check.....	98
5.10 Discharge Pressure Check.....	99
5.11 Outdoor Fan System Check	99
5.12 Main Circuit Short Check.....	100
5.13 Power Module Check	101

Part 7 Trial Operation and Field Settings..... 103

1. Tips for Servicing	104
1.1 Pump Down Operation	104
1.2 Forced Cooling Operation	104
2. Trial Operation	106
3. Field Settings	107
3.1 When 2 Units are installed in 1 Room	107
3.2 Model Type Setting	107
3.3 Standby Electricity Saving	108
3.4 Jumper Settings	109
4. Silicon Grease on Power Transistor / Diode Bridge	110





Part 8 Appendix..... 111

1. Piping Diagrams	112
1.1 Indoor Unit	112
1.2 Outdoor Unit	112
2. Wiring Diagrams	114
2.1 Indoor Unit	114
2.2 Outdoor Unit	114



1. Safety Cautions

Be sure to read the following safety cautions before conducting repair work. After the repair work is complete, be sure to conduct a test operation to ensure that the equipment operates normally, and explain the cautions for operating the product to the customer.







Caution Items





The caution items are classified into  **Warning** and  **Caution**. The  **Warning** items are especially important since they can lead to death or serious injury if they are not followed closely. The  **Caution** items can also lead to serious accidents under some conditions if they are not followed. Therefore, be sure to observe all the safety caution items described below.







Pictograms



-  This symbol indicates the item for which caution must be exercised. The pictogram shows the item to which attention must be paid.
-  This symbol indicates the prohibited action. The prohibited item or action is shown in the illustration or near the symbol.
-  This symbol indicates the action that must be taken, or the instruction. The instruction is shown in the illustration or near the symbol.

1.1 Warnings and Cautions Regarding Safety of Workers









 Warning	
Do not store the equipment in a room with successive fire sources (e.g., naked flame, gas appliance, electric heater).	
Be sure to disconnect the power cable plug from the plug socket before disassembling the equipment for repair. Working on the equipment that is connected to the power supply may cause an electrical shock. If it is necessary to supply power to the equipment to conduct the repair or inspecting the circuits, do not touch any electrically charged sections of the equipment.	
If the refrigerant gas is discharged during the repair work, do not touch the discharged refrigerant gas. The refrigerant gas may cause frostbite.	
When disconnecting the suction or discharge pipe of the compressor at the welded section, evacuate the refrigerant gas completely at a well-ventilated place first. If there is gas remaining inside the compressor, the refrigerant gas or refrigerating machine oil discharges when the pipe is disconnected, and it may cause injury.	
If the refrigerant gas leaks during the repair work, ventilate the area. The refrigerant gas may generate toxic gases when it contacts flames.	
Be sure to discharge the capacitor completely before conducting repair work. The step-up capacitor supplies high-voltage electricity to the electrical components of the outdoor unit. A charged capacitor may cause an electrical shock.	









 Warning	
<p>Do not start or stop the air conditioner operation by plugging or unplugging the power cable plug. Plugging or unplugging the power cable plug to operate the equipment may cause an electrical shock or fire.</p>	
<p>Be sure to wear a safety helmet, gloves, and a safety belt when working at a high place (more than 2 m). Insufficient safety measures may cause a fall accident.</p>	
<p>In case of R-32 / R-410A refrigerant models, be sure to use pipes, flare nuts and tools for the exclusive use of the R-32 / R-410A refrigerant. The use of materials for R-22 refrigerant models may cause a serious accident such as a damage of refrigerant cycle as well as an equipment failure.</p>	
<p>Do not mix air or gas other than the specified refrigerant (R-32 / R-410A / R-22) in the refrigerant system. If air enters the refrigerating system, an excessively high pressure results, causing equipment damage and injury.</p>	



 Caution	
<p>Do not repair the electrical components with wet hands. Working on the equipment with wet hands may cause an electrical shock.</p>	
<p>Do not clean the air conditioner by splashing water. Washing the unit with water may cause an electrical shock.</p>	
<p>Be sure to provide the earth / grounding when repairing the equipment in a humid or wet place, to avoid electrical shocks.</p>	
<p>Be sure to turn off the power switch and unplug the power cable when cleaning the equipment. The internal fan rotates at a high speed, and may cause injury.</p>	
<p>Be sure to conduct repair work with appropriate tools. The use of inappropriate tools may cause injury.</p>	
<p>Be sure to check that the refrigerating cycle section has cooled down enough before conducting repair work. Working on the unit when the refrigerating cycle section is hot may cause burns.</p>	









 Caution	
<p>Use the welder in a well-ventilated place. Using the welder in an enclosed room may cause oxygen deficiency.</p>	

1.2 Warnings and Cautions Regarding Safety of Users

 Warning	
<p>Do not store the equipment in a room with successive fire sources (e.g., naked flame, gas appliance, electric heater).</p>	
<p>Be sure to use parts listed in the service parts list of the applicable model and appropriate tools to conduct repair work. Never attempt to modify the equipment. The use of inappropriate parts or tools may cause an electrical shock, excessive heat generation or fire.</p>	
<p>If the power cable and lead wires have scratches or deteriorated, be sure to replace them. Damaged cable and wires may cause an electrical shock, excessive heat generation or fire.</p>	
<p>Do not use a joined power cable or extension cable, or share the same power outlet with other electrical appliances, since it may cause an electrical shock, excessive heat generation or fire.</p>	
<p>Be sure to use an exclusive power circuit for the equipment, and follow the local technical standards related to the electrical equipment, the internal wiring regulations, and the instruction manual for installation when conducting electrical work. Insufficient power circuit capacity and improper electrical work may cause an electrical shock or fire.</p>	
<p>Be sure to use the specified cable for wiring between the indoor and outdoor units. Make the connections securely and route the cable properly so that there is no force pulling the cable at the connection terminals. Improper connections may cause excessive heat generation or fire.</p>	
<p>When wiring between the indoor and outdoor units, make sure that the terminal cover does not lift off or dismount because of the cable. If the cover is not mounted properly, the terminal connection section may cause an electrical shock, excessive heat generation or fire.</p>	
<p>Do not damage or modify the power cable. Damaged or modified power cable may cause an electrical shock or fire. Placing heavy items on the power cable, and heating or pulling the power cable may damage the cable.</p>	





 Warning	
<p>Do not mix air or gas other than the specified refrigerant (R-32 / R-410A / R-22) in the refrigerant system. If air enters the refrigerating system, an excessively high pressure results, causing equipment damage and injury.</p>	
<p>If the refrigerant gas leaks, be sure to locate the leaking point and repair it before charging the refrigerant. After charging refrigerant, make sure that there is no refrigerant leak. If the leaking point cannot be located and the repair work must be stopped, be sure to perform pump-down and close the service valve, to prevent the refrigerant gas from leaking into the room. The refrigerant gas itself is harmless, but it may generate toxic gases when it contacts flames, such as fan and other heaters, stoves and ranges.</p>	
<p>When relocating the equipment, make sure that the new installation site has sufficient strength to withstand the weight of the equipment. If the installation site does not have sufficient strength and if the installation work is not conducted securely, the equipment may fall and cause injury.</p>	
<p>Check to make sure that the power cable plug is not dirty or loose, then insert the plug into a power outlet securely. If the plug has dust or loose connection, it may cause an electrical shock or fire.</p>	
<p>Be sure to install the product correctly by using the provided standard installation frame. Incorrect use of the installation frame and improper installation may cause the equipment to fall, resulting in injury.</p>	For unitary type only 
<p>Be sure to install the product securely in the installation frame mounted on the window frame. If the unit is not securely mounted, it may fall and cause injury.</p>	For unitary type only 
<p>When replacing the coin battery in the remote controller, be sure to dispose of the old battery to prevent children from swallowing it. If a child swallows the coin battery, see a doctor immediately.</p>	

 Caution	
<p>Installation of a leakage breaker is necessary in some cases depending on the conditions of the installation site, to prevent electrical shocks.</p>	
<p>Do not install the equipment in a place where there is a possibility of combustible gas leaks. If the combustible gas leaks and remains around the unit, it may cause a fire.</p>	

 Caution	
<p>Check to see if the parts and wires are mounted and connected properly, and if the connections at the soldered or crimped terminals are secure. Improper installation and connections may cause excessive heat generation, fire or an electrical shock.</p>	
<p>If the installation platform or frame has corroded, replace it. Corroded installation platform or frame may cause the unit to fall, resulting in injury.</p>	
<p>Check the earth / grounding, and repair it if the equipment is not properly earthed / grounded. Improper earth / grounding may cause an electrical shock.</p>	
<p>Be sure to measure the insulation resistance after the repair, and make sure that the resistance is 1 MΩ or higher. Faulty insulation may cause an electrical shock.</p>	
<p>Be sure to check the drainage of the indoor unit after the repair. Faulty drainage may cause the water to enter the room and wet the furniture and floor.</p>	
<p>Do not tilt the unit when removing it. The water inside the unit may spill and wet the furniture and floor.</p>	
<p>Be sure to install the packing and seal on the installation frame properly. If the packing and seal are not installed properly, water may enter the room and wet the furniture and floor.</p>	<p>For unitary type only</p> <div style="text-align: center;">  </div>

2. Used Icons

The following icons are used to attract the attention of the reader to specific information.

Icon	Type of Information	Description
 Warning	Warning	A Warning is used when there is danger of personal injury.
 Caution	Caution	A Caution is used when there is danger that the reader, through incorrect manipulation, may damage equipment, lose data, get an unexpected result or has to restart (part of) a procedure.
 Note:	Note	A Note provides information that is not indispensable, but may nevertheless be valuable to the reader, such as tips and tricks.
	Reference	A Reference guides the reader to other places in this binder or in this manual, where he/she will find additional information on a specific topic.

Part 1

List of Functions

1. Functions.....2

1. Functions

Category	Functions	FTXG20/25/35/50LV1BW(S) FXG20/25/35/50L2V1B	Category	Functions	FTXG20/25/35/50LV1BW(S) FXG20/25/35/50L2V1B
Basic Function	Inverter (with inverter power control)	●	Health & Clean	Air-purifying filter	—
	PAM control	●		Photocatalytic deodorizing filter	—
	Standby electricity saving	●		Air-purifying filter with photocatalytic deodorizing function	—
Compressor	Oval scroll compressor	—	Timer	Titanium apatite photocatalytic air-purifying filter	●
	Swing compressor	●		Air filter (prefilter)	●
	Rotary compressor	—		Wipe-clean flat panel	●
	Reluctance DC motor	●		Washable grille	—
Comfortable Airflow	Power-airflow flap	—	Worry Free (Reliability & Durability)	MOLD PROOF operation	—
	Power-airflow dual flaps	●		Heating dry operation	—
	Power-airflow diffuser	—		Good-sleep cooling operation	—
	Wide-angle louvers	●		WEEKLY TIMER operation	●
	Auto-swing (up and down)	●		24-hour ON/OFF timer	●
	Auto-swing (right and left)	●		NIGHT SET mode	●
	3-D airflow	●		Auto-restart (after power failure)	●
	COMFORT AIRFLOW operation	●		Self-diagnosis (digital, led) display	●
Comfort Control	Auto fan speed	●	Flexibility	Wiring error check function	—
	Indoor unit quiet operation	●		Anti-corrosion treatment of outdoor heat exchanger	●
	NIGHT QUIET mode (automatic)	—		Multi-split / split type compatible indoor unit	●
	OUTDOOR UNIT QUIET operation (manual)	●		Flexible power supply correspondence	—
	INTELLIGENT EYE operation	●		High ceiling application	—
	Quick warming function (preheating operation)	●		Chargeless	10 m
	Hot-start function	●		Either side drain (right or left)	●
	Automatic defrosting	●		Power selection	—
Operation	Automatic operation	●	Remote Control	5-room centralized controller (option)	●
	Program dry operation	●		Remote control adaptor (normal open pulse contact) (option)	●
	Fan only	●		Remote control adaptor (normal open contact) (option)	●
Lifestyle Convenience	New POWERFUL operation (non-inverter)	—	Remote Controller	DIII-NET compatible (adaptor) (option)	●
	Inverter POWERFUL operation	●		Wireless	●
	Priority-room setting	—		Wired (option)	—
	COOL / HEAT mode lock	—			
	HOME LEAVE operation	—			
	ECONO operation	●			
	Indoor unit ON/OFF button	●			
	Signal receiving sign	●			
	Multi-colored indicator lamp (multi-monitor lamp)	●			
	Monitor brightness setting	●			
R/C with back light	●				
Temperature display	—				

Note: ● : Available
— : Not available

Part 2 Specifications

1. Specifications4

1. Specifications

50 Hz, 220 - 230 - 240 V

Model	Indoor Unit		FTXG20LV1BW		FTXG20LV1BS	
	Outdoor Unit		RXG20L2V1B		RXG20L2V1B	
			Cooling	Heating	Cooling	Heating
Capacity Rated (Min. ~ Max.)	kW		2.3 (1.3 ~ 2.8)	2.5 (1.3 ~ 4.3)	2.3 (1.3 ~ 2.8)	2.5 (1.3 ~ 4.3)
	Btu/h		7,800 (4,400 ~ 9,500)	8,500 (4,400 ~ 14,600)	7,800 (4,400 ~ 9,500)	8,500 (4,400 ~ 14,600)
	kcal/h		1,980 (1,120 ~ 2,410)	2,150 (1,120 ~ 3,700)	1,980 (1,120 ~ 2,410)	2,150 (1,120 ~ 3,700)
Running Current (Rated)	A		2.8 - 2.7 - 2.6	2.8 - 2.7 - 2.6	2.8 - 2.7 - 2.6	2.8 - 2.7 - 2.6
Power Consumption Rated (Min. ~ Max.)	W		501 (320 ~ 760)	500 (310 ~ 1,120)	501 (320 ~ 760)	500 (310 ~ 1,120)
Power Factor (Rated)	%		81.3 - 80.7 - 80.2	81.1 - 80.5 - 80.1	81.3 - 80.7 - 80.2	81.1 - 80.5 - 80.1
EER (Cooling) / COP (Heating) Rated (Min. ~ Max.)	W/W		4.59 (4.06 ~ 3.68)	5.00 (4.19 ~ 3.84)	4.59 (4.06 ~ 3.68)	5.00 (4.19 ~ 3.84)
Piping Connections	Liquid	mm	φ 6.4		φ 6.4	
	Gas	mm	φ 9.5		φ 9.5	
	Drain	mm	φ 18.0		φ 18.0	
Heat Insulation			Both Liquid and Gas Pipes		Both Liquid and Gas Pipes	
Max. Interunit Piping Length	m		20		20	
Max. Interunit Height Difference	m		15		15	
Chargeless	m		10		10	
Amount of Additional Charge of Refrigerant	g/m		20		20	
Indoor Unit			FTXG20LV1BW		FTXG20LV1BS	
Front Panel Color			White		Silver	
Airflow Rate	H	m ³ /min (cfm)	8.9 (313)	10.2 (361)	8.9 (313)	10.2 (361)
	M		6.6 (234)	8.4 (298)	6.6 (234)	8.4 (298)
	L		4.4 (155)	6.3 (223)	4.4 (155)	6.3 (223)
	SL		2.6 (91)	3.8 (133)	2.6 (91)	3.8 (133)
Fan	Type		Cross Flow Fan		Cross Flow Fan	
	Motor Output	W	29		29	
	Speed	Steps	5 Steps, Quiet, Auto		5 Steps, Quiet, Auto	
Air Direction Control			Right, Left, Horizontal, Downwards		Right, Left, Horizontal, Downwards	
Air Filter			Removable / Washable / Mildew Proof		Removable / Washable / Mildew Proof	
Running Current (Rated)	A		0.12 - 0.12 - 0.12	0.15 - 0.15 - 0.15	0.12 - 0.12 - 0.12	0.15 - 0.15 - 0.15
Power Consumption (Rated)	W		23 - 23 - 23	31 - 31 - 31	23 - 23 - 23	31 - 31 - 31
Power Factor (Rated)	%		87.1 - 83.3 - 79.9	93.9 - 89.9 - 86.1	87.1 - 83.3 - 79.9	93.9 - 89.9 - 86.1
Temperature Control			Microcomputer Control		Microcomputer Control	
Dimensions (H x W x D)	mm		303 x 998 x 212		303 x 998 x 212	
Packaged Dimensions (H x W x D)	mm		322 x 1,101 x 389		322 x 1,101 x 389	
Weight (Mass)	kg		12		12	
Gross Weight (Gross Mass)	kg		16		16	
Sound Pressure Level	H / M / L / SL	dB(A)	38 / 32 / 25 / 19	40 / 34 / 28 / 19	38 / 32 / 25 / 19	40 / 34 / 28 / 19
Sound Power Level	dB		54	56	54	56
Outdoor Unit			RXG20L2V1B		RXG20L2V1B	
Casing Color			Ivory White		Ivory White	
Compressor	Type		Hermetically Sealed Swing Type		Hermetically Sealed Swing Type	
	Model		1YC23APXD		1YC23APXD	
	Motor Output	W	600		600	
Refrigerant Oil	Type		FVC50K		FVC50K	
	Charge	L	0.375		0.375	
Refrigerant	Type		R-410A		R-410A	
	Charge	kg	1.05		1.05	
Airflow Rate	H	m ³ /min (cfm)	34.5 (1,218)	31.1 (1,098)	34.5 (1,218)	31.1 (1,098)
	SL		31.0 (1,094)	26.4 (932)	31.0 (1,094)	26.4 (932)
Fan	Type		Propeller		Propeller	
	Motor Output	W	23		23	
Running Current (Rated)	A		2.68 - 2.58 - 2.48	2.65 - 2.55 - 2.45	2.68 - 2.58 - 2.48	2.65 - 2.55 - 2.45
Power Consumption (Rated)	W		478 - 478 - 478	472 - 472 - 472	478 - 478 - 478	472 - 472 - 472
Power Factor (Rated)	%		81.1 - 80.6 - 80.3	81.0 - 80.5 - 80.3	81.1 - 80.6 - 80.3	81.0 - 80.5 - 80.3
Starting Current	A		2.8		2.8	
Dimensions (H x W x D)	mm		550 x 765 x 285		550 x 765 x 285	
Packaged Dimensions (H x W x D)	mm		612 x 906 x 402		612 x 906 x 402	
Weight (Mass)	kg		35		35	
Gross Weight (Gross Mass)	kg		38		38	
Sound Pressure Level	H / SL	dB(A)	46 / 43	47 / 44	46 / 43	47 / 44
Sound Power Level	dB		61	62	61	62
Drawing No.			3D086752		3D086756	

Note: ■ The data are based on the conditions shown in the table below.

Cooling	Heating	Piping Length
Indoor ; 27°CDB / 19°CWB	Indoor ; 20°CDB	5 m
Outdoor ; 35°CDB / 24°CWB	Outdoor ; 7°CDB / 6°CWB	

Conversion Formulae
kcal/h = kW × 860
Btu/h = kW × 3412
cfm = m ³ /min × 35.3

50 Hz, 220 - 230 - 240 V

Model	Indoor Unit		FTXG25LV1BW		FTXG25LV1BS	
	Outdoor Unit		RXG25L2V1B		RXG25L2V1B	
			Cooling	Heating	Cooling	Heating
Capacity Rated (Min. ~ Max.)	kW		2.4 (1.3 ~ 3.0)	3.4 (1.3 ~ 4.5)	2.4 (1.3 ~ 3.0)	3.4 (1.3 ~ 4.5)
	Btu/h		8,200 (4,400 ~ 10,200)	11,600 (4,400 ~ 15,400)	8,200 (4,400 ~ 10,200)	11,600 (4,400 ~ 15,400)
	kcal/h		2,060 (1,120 ~ 2,580)	2,920 (1,120 ~ 3,870)	2,060 (1,120 ~ 2,580)	2,920 (1,120 ~ 3,870)
Running Current (Rated)	A		2.9 - 2.8 - 2.7	4.4 - 4.2 - 4.0	2.9 - 2.8 - 2.7	4.4 - 4.2 - 4.0
Power Consumption Rated (Min. ~ Max.)	W		523 (320 ~ 820)	769 (310 ~ 1,320)	523 (320 ~ 820)	769 (310 ~ 1,320)
Power Factor (Rated)	%		82.0 - 81.2 - 80.7	79.4 - 79.6 - 80.1	82.0 - 81.2 - 80.7	79.4 - 79.6 - 80.1
EER (Cooling) / COP (Heating) Rated (Min. ~ Max.)	W/W		4.59 (4.06 ~ 3.66)	4.42 (4.19 ~ 3.41)	4.59 (4.06 ~ 3.66)	4.42 (4.19 ~ 3.41)
Piping Connections	Liquid	mm	φ 6.4		φ 6.4	
	Gas	mm	φ 9.5		φ 9.5	
	Drain	mm	φ 18.0		φ 18.0	
Heat Insulation			Both Liquid and Gas Pipes		Both Liquid and Gas Pipes	
Max. Interunit Piping Length	m		20		20	
Max. Interunit Height Difference	m		15		15	
Chargeless	m		10		10	
Amount of Additional Charge of Refrigerant	g/m		20		20	
Indoor Unit			FTXG25LV1BW		FTXG25LV1BS	
Front Panel Color			White		Silver	
Airflow Rate	H	m ³ /min (cfm)	8.9 (313)	11.0 (388)	8.9 (313)	11.0 (388)
	M		6.6 (234)	8.6 (303)	6.6 (234)	8.6 (303)
	L		4.4 (155)	6.3 (223)	4.4 (155)	6.3 (223)
	SL		2.6 (91)	3.8 (133)	2.6 (91)	3.8 (133)
Fan	Type		Cross Flow Fan		Cross Flow Fan	
	Motor Output	W	29		29	
	Speed	Steps	5 Steps, Quiet, Auto		5 Steps, Quiet, Auto	
Air Direction Control			Right, Left, Horizontal, Downwards		Right, Left, Horizontal, Downwards	
Air Filter			Removable / Washable / Mildew Proof		Removable / Washable / Mildew Proof	
Running Current (Rated)	A		0.12 - 0.12 - 0.12	0.16 - 0.16 - 0.16	0.12 - 0.12 - 0.12	0.16 - 0.16 - 0.16
Power Consumption (Rated)	W		23 - 23 - 23	33 - 33 - 33	23 - 23 - 23	33 - 33 - 33
Power Factor (Rated)	%		87.1 - 83.3 - 79.9	93.8 - 89.6 - 85.9	87.1 - 83.3 - 79.9	93.8 - 89.6 - 85.9
Temperature Control			Microcomputer Control		Microcomputer Control	
Dimensions (H x W x D)	mm		303 x 998 x 212		303 x 998 x 212	
Packaged Dimensions (H x W x D)	mm		322 x 1,101 x 389		322 x 1,101 x 389	
Weight (Mass)	kg		12		12	
Gross Weight (Gross Mass)	kg		16		16	
Sound Pressure Level	H / M / L / SL	dB(A)	38 / 32 / 25 / 19	41 / 34 / 28 / 19	38 / 32 / 25 / 19	41 / 34 / 28 / 19
Sound Power Level	dB		54	56	54	56
Outdoor Unit			RXG25L2V1B		RXG25L2V1B	
Casing Color			Ivory White		Ivory White	
Compressor	Type		Hermetically Sealed Swing Type		Hermetically Sealed Swing Type	
	Model		1YC23APXD		1YC23APXD	
	Motor Output	W	600		600	
Refrigerant Oil	Type		FVC50K		FVC50K	
	Charge	L	0.375		0.375	
Refrigerant	Type		R-410A		R-410A	
	Charge	kg	1.05		1.05	
Airflow Rate	H	m ³ /min (cfm)	34.5 (1,218)	31.1 (1,098)	34.5 (1,218)	31.1 (1,098)
	SL		31.0 (1,094)	26.4 (932)	31.0 (1,094)	26.4 (932)
Fan	Type		Propeller		Propeller	
	Motor Output	W	23		23	
Running Current (Rated)	A		2.78 - 2.68 - 2.58	4.24 - 4.04 - 3.84	2.78 - 2.68 - 2.58	4.24 - 4.04 - 3.84
Power Consumption (Rated)	W		500 - 500 - 500	736 - 736 - 736	500 - 500 - 500	736 - 736 - 736
Power Factor (Rated)	%		81.8 - 81.1 - 80.7	78.9 - 79.2 - 79.8	81.8 - 81.1 - 80.7	78.9 - 79.2 - 79.8
Starting Current	A		4.4		4.4	
Dimensions (H x W x D)	mm		550 x 765 x 285		550 x 765 x 285	
Packaged Dimensions (H x W x D)	mm		612 x 906 x 402		612 x 906 x 402	
Weight (Mass)	kg		35		35	
Gross Weight (Gross Mass)	kg		38		38	
Sound Pressure Level	H / SL	dB(A)	46 / 43	47 / 44	46 / 43	47 / 44
Sound Power Level	dB		61	62	61	62
Drawing No.			3D086753		3D086757	

Note: ■ The data are based on the conditions shown in the table below.

Cooling	Heating	Piping Length
Indoor ; 27°CDB / 19°CWB	Indoor ; 20°CDB	5 m
Outdoor ; 35°CDB / 24°CWB	Outdoor ; 7°CDB / 6°CWB	

Conversion Formulae
kcal/h = kW × 860
Btu/h = kW × 3412
cfm = m ³ /min × 35.3

50 Hz, 220 - 230 - 240 V

Model	Indoor Unit		FTXG35LV1BW		FTXG35LV1BS	
	Outdoor Unit		RXG35L2V1B		RXG35L2V1B	
			Cooling	Heating	Cooling	Heating
Capacity Rated (Min. ~ Max.)	kW		3.5 (1.4 ~ 3.8)	4.0 (1.4 ~ 5.0)	3.5 (1.4 ~ 3.8)	4.0 (1.4 ~ 5.0)
	Btu/h		11,900 (4,800 ~ 13,000)	13,600 (4,800 ~ 17,100)	11,900 (4,800 ~ 13,000)	13,600 (4,800 ~ 17,100)
	kcal/h		3,010 (1,200 ~ 3,270)	3,440 (1,200 ~ 4,300)	3,010 (1,200 ~ 3,270)	3,440 (1,200 ~ 4,300)
Running Current (Rated)	A		5.0 - 4.8 - 4.6	5.5 - 5.3 - 5.1	5.0 - 4.8 - 4.6	5.5 - 5.3 - 5.1
Power Consumption Rated (Min. ~ Max.)	W		882 (350 ~ 1,190)	985 (320 ~ 1,490)	882 (350 ~ 1,190)	985 (320 ~ 1,490)
Power Factor (Rated)	%		80.2 - 79.9 - 79.9	81.1 - 80.8 - 80.5	80.2 - 79.9 - 79.9	81.1 - 80.8 - 80.5
EER (Cooling) / COP (Heating) Rated (Min. ~ Max.)	W/W		3.97 (4.06 ~ 3.19)	4.06 (4.38 ~ 3.36)	3.97 (4.06 ~ 3.19)	4.06 (4.38 ~ 3.36)
Piping Connections	Liquid	mm	φ 6.4		φ 6.4	
	Gas	mm	φ 9.5		φ 9.5	
	Drain	mm	φ 18.0		φ 18.0	
Heat Insulation			Both Liquid and Gas Pipes		Both Liquid and Gas Pipes	
Max. Interunit Piping Length	m		20		20	
Max. Interunit Height Difference	m		15		15	
Chargeless	m		10		10	
Amount of Additional Charge of Refrigerant	g/m		20		20	
Indoor Unit			FTXG35LV1BW		FTXG35LV1BS	
Front Panel Color			White		Silver	
Airflow Rate	H	m³/min (cfm)	10.9 (385)	12.4 (438)	10.9 (385)	12.4 (438)
	M		7.8 (276)	9.6 (340)	7.8 (276)	9.6 (340)
	L		4.8 (168)	6.9 (245)	4.8 (168)	6.9 (245)
	SL		2.9 (102)	4.1 (144)	2.9 (102)	4.1 (144)
Fan	Type		Cross Flow Fan		Cross Flow Fan	
	Motor Output	W	29		29	
	Speed	Steps	5 Steps, Quiet, Auto		5 Steps, Quiet, Auto	
Air Direction Control			Right, Left, Horizontal, Downwards		Right, Left, Horizontal, Downwards	
Air Filter			Removable / Washable / Mildew Proof		Removable / Washable / Mildew Proof	
Running Current (Rated)	A		0.16 - 0.16 - 0.16	0.21 - 0.21 - 0.21	0.16 - 0.16 - 0.16	0.21 - 0.21 - 0.21
Power Consumption (Rated)	W		33 - 33 - 33	42 - 42 - 42	33 - 33 - 33	42 - 42 - 42
Power Factor (Rated)	%		93.8 - 89.6 - 85.9	90.9 - 87.0 - 83.3	93.8 - 89.6 - 85.9	90.9 - 87.0 - 83.3
Temperature Control			Microcomputer Control		Microcomputer Control	
Dimensions (H x W x D)	mm		303 x 998 x 212		303 x 998 x 212	
Packaged Dimensions (H x W x D)	mm		322 x 1,101 x 389		322 x 1,101 x 389	
Weight (Mass)	kg		12		12	
Gross Weight (Gross Mass)	kg		16		16	
Sound Pressure Level	H / M / L / SL	dB(A)	45 / 34 / 26 / 20	45 / 37 / 29 / 20	45 / 34 / 26 / 20	45 / 37 / 29 / 20
Sound Power Level	dB		59	59	59	59
Outdoor Unit			RXG35L2V1B		RXG35L2V1B	
Casing Color			Ivory White		Ivory White	
Compressor	Type		Hermetically Sealed Swing Type		Hermetically Sealed Swing Type	
	Model		1YC23APXD		1YC23APXD	
	Motor Output	W	600		600	
Refrigerant Oil	Type		FVC50K		FVC50K	
	Charge	L	0.375		0.375	
Refrigerant	Type		R-410A		R-410A	
	Charge	kg	1.05		1.05	
Airflow Rate	H	m³/min (cfm)	37.0 (1,306)	31.1 (1,098)	37.0 (1,306)	31.1 (1,098)
	SL		31.0 (1,094)	26.4 (932)	31.0 (1,094)	26.4 (932)
Fan	Type		Propeller		Propeller	
	Motor Output	W	23		23	
Running Current (Rated)	A		4.84 - 4.64 - 4.44	5.29 - 5.09 - 4.89	4.84 - 4.64 - 4.44	5.29 - 5.09 - 4.89
Power Consumption (Rated)	W		849 - 849 - 849	943 - 943 - 943	849 - 849 - 849	943 - 943 - 943
Power Factor (Rated)	%		79.7 - 79.6 - 79.7	81.0 - 80.6 - 80.4	79.7 - 79.6 - 79.7	81.0 - 80.6 - 80.4
Starting Current	A		5.5		5.5	
Dimensions (H x W x D)	mm		550 x 765 x 285		550 x 765 x 285	
Packaged Dimensions (H x W x D)	mm		612 x 906 x 402		612 x 906 x 402	
Weight (Mass)	kg		35		35	
Gross Weight (Gross Mass)	kg		38		38	
Sound Pressure Level	H / SL	dB(A)	48 / 44	48 / 45	48 / 44	48 / 45
Sound Power Level	dB		63	63	63	63
Drawing No.			3D086754		C: 3D086758	

Note: ■ The data are based on the conditions shown in the table below.

Cooling	Heating	Piping Length
Indoor ; 27°CDB / 19°CWB	Indoor ; 20°CDB	5 m
Outdoor ; 35°CDB / 24°CWB	Outdoor ; 7°CDB / 6°CWB	

Conversion Formulae
kcal/h = kW x 860
Btu/h = kW x 3412
cfm = m³/min x 35.3

50 Hz, 220 - 230 - 240 V

Model	Indoor Unit		FTXG50LV1BW		FTXG50LV1BS	
	Outdoor Unit		RXG50L2V1B		RXG50L2V1B	
			Cooling	Heating	Cooling	Heating
Capacity Rated (Min. ~ Max.)	kW		4.8 (1.7 ~ 5.3)	5.8 (1.7 ~ 6.5)	4.8 (1.7 ~ 5.3)	5.8 (1.7 ~ 6.5)
	Btu/h		16,400 (5,800 ~ 18,100)	19,800 (5,800 ~ 22,200)	16,400 (5,800 ~ 18,100)	19,800 (5,800 ~ 22,200)
	kcal/h		4,130 (1,460 ~ 4,560)	4,990 (1,460 ~ 5,590)	4,130 (1,460 ~ 4,560)	4,990 (1,460 ~ 5,590)
Running Current (Rated)	A		6.5 - 6.2 - 5.9	7.4 - 7.1 - 6.8	6.5 - 6.2 - 5.9	7.4 - 7.1 - 6.8
Power Consumption Rated (Min. ~ Max.)	W		1,360 (370 ~ 1,880)	1,589 (310 ~ 2,490)	1,360 (370 ~ 1,880)	1,589 (310 ~ 2,490)
Power Factor (Rated)	%		95.1 - 95.4 - 96.0	97.6 - 97.3 - 97.4	95.1 - 95.4 - 96.0	97.6 - 97.3 - 97.4
EER (Cooling) / COP (Heating) Rated (Min. ~ Max.)	W/W		3.53 (4.59 ~ 2.82)	3.65 (5.48 ~ 2.61)	3.53 (4.59 ~ 2.82)	3.65 (5.48 ~ 2.61)
Piping Connections	Liquid	mm	φ 6.4		φ 6.4	
	Gas	mm	φ 12.7		φ 12.7	
	Drain	mm	φ 18.0		φ 18.0	
Heat Insulation			Both Liquid and Gas Pipes		Both Liquid and Gas Pipes	
Max. Interunit Piping Length	m		30		30	
Max. Interunit Height Difference	m		20		20	
Chargeless	m		10		10	
Amount of Additional Charge of Refrigerant	g/m		20		20	
Indoor Unit			FTXG50LV1BW		FTXG50LV1BS	
Front Panel Color			White		Silver	
Airflow Rate	H	m³/min (cfm)	10.9 (385)	12.6 (446)	10.9 (385)	12.6 (446)
	M		8.9 (313)	10.5 (372)	8.9 (313)	10.5 (372)
	L		6.8 (239)	8.1 (284)	6.8 (239)	8.1 (284)
	SL		3.6 (128)	5.0 (176)	3.6 (128)	5.0 (176)
Fan	Type		Cross Flow Fan		Cross Flow Fan	
	Motor Output	W	29		29	
	Speed	Steps	5 Steps, Quiet, Auto		5 Steps, Quiet, Auto	
Air Direction Control			Right, Left, Horizontal, Downwards		Right, Left, Horizontal, Downwards	
Air Filter			Removable / Washable / Mildew Proof		Removable / Washable / Mildew Proof	
Running Current (Rated)	A		0.16 - 0.16 - 0.16	0.21 - 0.21 - 0.21	0.16 - 0.16 - 0.16	0.21 - 0.21 - 0.21
Power Consumption (Rated)	W		33 - 33 - 33	43 - 43 - 43	33 - 33 - 33	43 - 43 - 43
Power Factor (Rated)	%		93.8 - 89.6 - 85.9	93.1 - 89.0 - 85.3	93.8 - 89.6 - 85.9	93.1 - 89.0 - 85.3
Temperature Control			Microcomputer Control		Microcomputer Control	
Dimensions (H x W x D)	mm		303 x 998 x 212		303 x 998 x 212	
Packaged Dimensions (H x W x D)	mm		322 x 1,101 x 389		322 x 1,101 x 389	
Weight (Mass)	kg		12		12	
Gross Weight (Gross Mass)	kg		16		16	
Sound Pressure Level	H / M / L / SL	dB(A)	46 / 40 / 35 / 32	47 / 41 / 35 / 32	46 / 40 / 35 / 32	47 / 41 / 35 / 32
Sound Power Level	dB		60	60	60	60
Outdoor Unit			RXG50L2V1B		RXG50L2V1B	
Casing Color			Ivory White		Ivory White	
Compressor	Type		Hermetically Sealed Swing Type		Hermetically Sealed Swing Type	
	Model		2YC36GXD		2YC36GXD	
	Motor Output	W	1,100		1,100	
Refrigerant Oil	Type		FVC50K		FVC50K	
	Charge	L	0.395		0.395	
Refrigerant	Type		R-410A		R-410A	
	Charge	kg	1.60		1.60	
Airflow Rate	H	m³/min (cfm)	49.8 (1,758)	44.8 (1,581)	49.8 (1,758)	44.8 (1,581)
	SL		42.6 (1,504)	38.3 (1,352)	42.6 (1,504)	38.3 (1,352)
Fan	Type		Propeller		Propeller	
	Motor Output	W	53		53	
Running Current (Rated)	A		6.34 - 6.04 - 5.74	7.19 - 6.89 - 6.59	6.34 - 6.04 - 5.74	7.19 - 6.89 - 6.59
Power Consumption (Rated)	W		1,327 - 1,327 - 1,327	1,546 - 1,546 - 1,546	1,327 - 1,327 - 1,327	1,546 - 1,546 - 1,546
Power Factor (Rated)	%		95.1 - 95.5 - 96.3	97.7 - 97.6 - 97.7	95.1 - 95.5 - 96.3	97.7 - 97.6 - 97.7
Starting Current	A		7.4		7.4	
Dimensions (H x W x D)	mm		735 x 825 x 300		735 x 825 x 300	
Packaged Dimensions (H x W x D)	mm		797 x 992 x 437		797 x 992 x 437	
Weight (Mass)	kg		48		48	
Gross Weight (Gross Mass)	kg		52		52	
Sound Pressure Level	H / SL	dB(A)	48 / 44	48 / 44	48 / 44	48 / 44
Sound Power Level	dB		63	63	63	63
Drawing No.			3D086755		C: 3D086759	

Note: ■ The data are based on the conditions shown in the table below.

Cooling	Heating	Piping Length
Indoor ; 27°CDB / 19°CWB	Indoor ; 20°CDB	5 m
Outdoor ; 35°CDB / 24°CWB	Outdoor ; 7°CDB / 6°CWB	

Conversion Formulae
kcal/h = kW × 860
Btu/h = kW × 3412
cfm = m³/min × 35.3

Part 3

Printed Circuit Board

Connector Wiring Diagram

1. Indoor Unit.....	9
2. Outdoor Unit.....	11
2.1 20/25/35 Class	11
2.2 50 Class	13

1. Indoor Unit

Control PCB (A1P)

- | | |
|----------------|--|
| 1) S21 | Connector for centralized control (HA) |
| 2) S25 | Connector for INTELLIGENT EYE sensor PCB |
| 3) S32 | Indoor heat exchanger thermistor |
| 4) S41 | Connector for swing motors |
| 5) S42 | Connector for reduction motor (front panel mechanism) and limit switch |
| 6) S46 | Connector for signal receiver / display PCB |
| 7) S200 | Connector for fan motor |
| 8) H1, H2, H3, | Connector for terminal board (indoor - outdoor transmission) |
| 9) FG | Connector for terminal board (frame ground) |
| 10) JB | Fan speed setting when compressor stops for thermostat OFF |
| JC | Power failure recovery function (auto-restart) |
| | * Refer to page 109 for detail. |
| 11) LED A | LED for service monitor (green) |
| 12) F1U, F2U | Fuse (3.15 A, 250 V) |
| 13) V1 | Varistor |

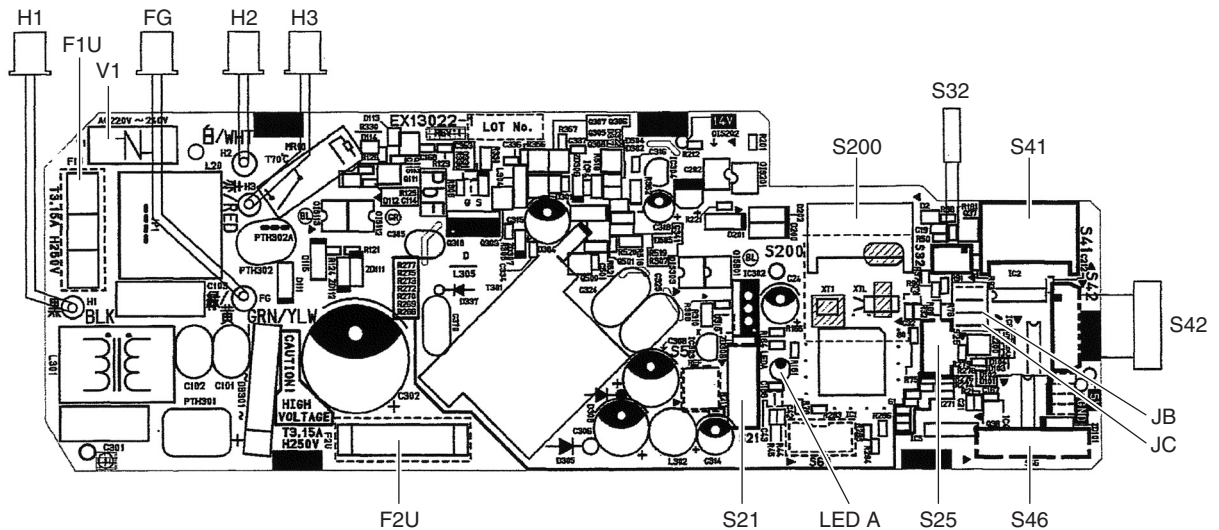

2P357399-1



Caution

Replace the PCB if you accidentally cut the jumpers other than JB and JC.

Jumpers are necessary for electronic circuit. Improper operation may occur if you cut any of them.

**Signal Receiver /
Display PCB
(A2P)**

- | | |
|--------|--|
| 1) S51 | Connector for control PCB |
| 2) S52 | Connector for room temperature thermistor |
| 3) S1W | Forced cooling operation ON/OFF button
* Refer to page 104 for detail. |
| 4) H1P | LED for operation (multi-color) |
| 5) H2P | LED for INTELLIGENT EYE (green) |
| 6) JA | Address setting jumper
* Refer to page 107 for detail. |

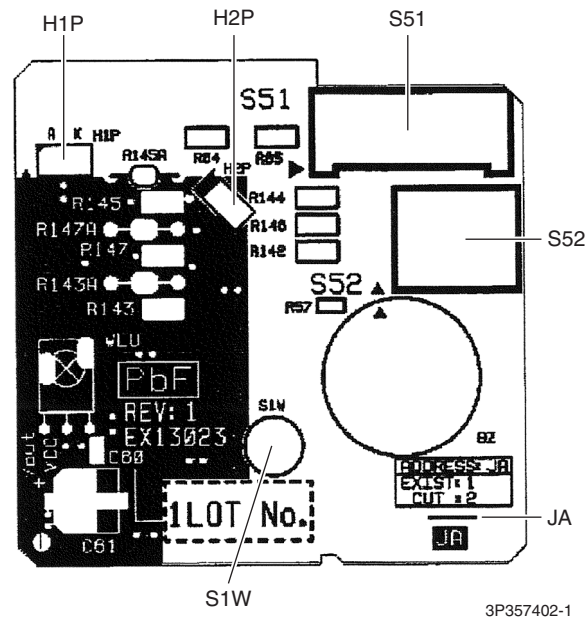

Caution

Replace the PCB if you accidentally cut the jumpers other than JA.

Jumpers are necessary for electronic circuit. Improper operation may occur if you cut any of them.

**INTELLIGENT
EYE Sensor PCB
(A3P)**

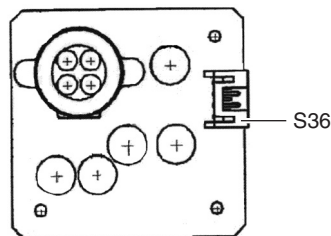
- | | |
|--------|---------------------------|
| 1) S36 | Connector for control PCB |
|--------|---------------------------|



3E860004-1

2. Outdoor Unit

2.1 20/25/35 Class

Main PCB (PCB2)

- | | |
|-------------|--|
| 1) S10 | Connector for filter PCB |
| 2) S20 | Connector for electronic expansion valve coil |
| 3) S40 | Connector for overload protector |
| 4) S50 | Connector for magnetic relay |
| 5) S70 | Connector for fan motor |
| 6) S80 | Connector for four way valve coil |
| 7) S90 | Connector for thermistors
(outdoor temperature, outdoor heat exchanger, discharge pipe) |
| 8) S100 | Connector for forced operation button PCB |
| 9) HL3, HN3 | Connector for filter PCB |
| 10) HR2 | Connector for reactor |
| 11) U, V, W | Connector for compressor |
| 12) FU2 | Fuse (3.15 A, 250 V) |
| 13) LED A | LED for service monitor (green) |
| 14) V1 | Varistor |
| 15) J5 | Jumper for improvement of defrost performance |
- * Refer to page 109 for detail.

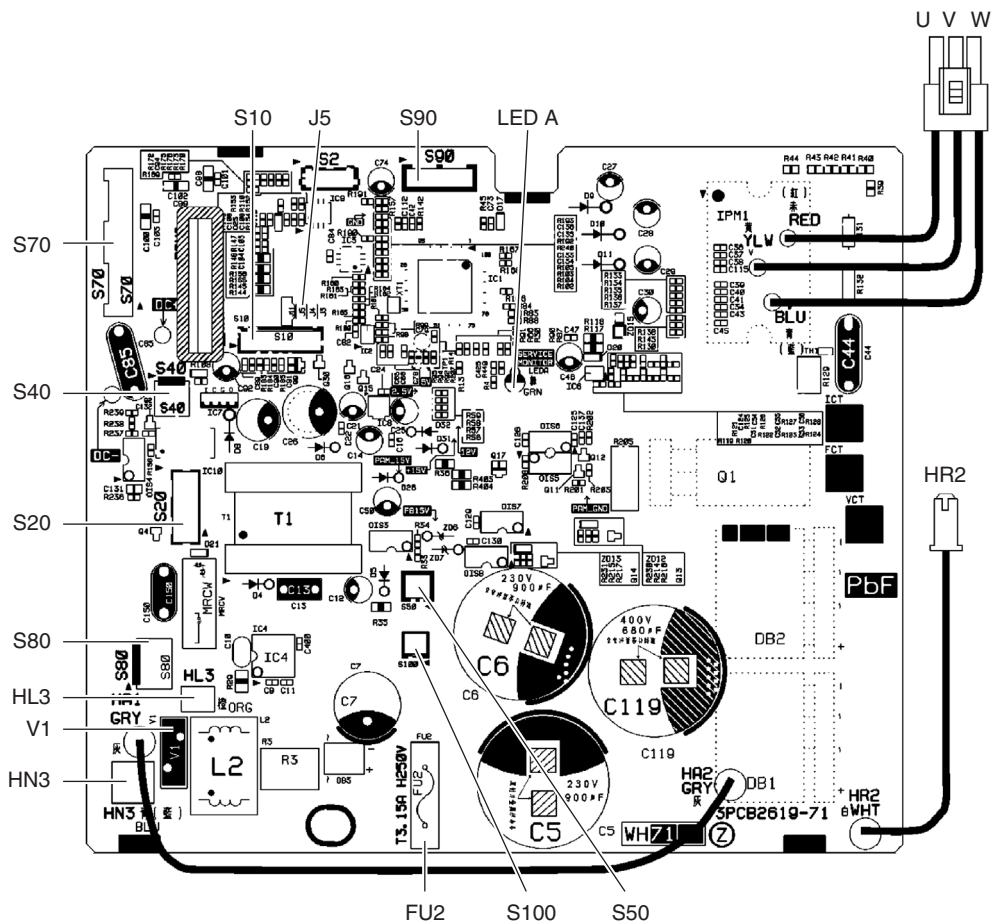

2P358715-2



Caution

Replace the PCB if you accidentally cut the jumpers other than J5.

Jumpers are necessary for electronic circuit. Improper operation may occur if you cut any of them.

Filter PCB (PCB1)

- 1) S11 Connector for main PCB
- 2) AC1, AC2, S Connector for terminal board
- 3) E1, E2 Terminal for earth wire
- 4) HL2, HN2 Connector for main PCB
- 5) HR1 Connector for reactor
- 6) FU1 Fuse (3.15 A, 250 V)
- 7) FU3 Fuse (20 A, 250 V)
- 8) V2, V3 Varistor

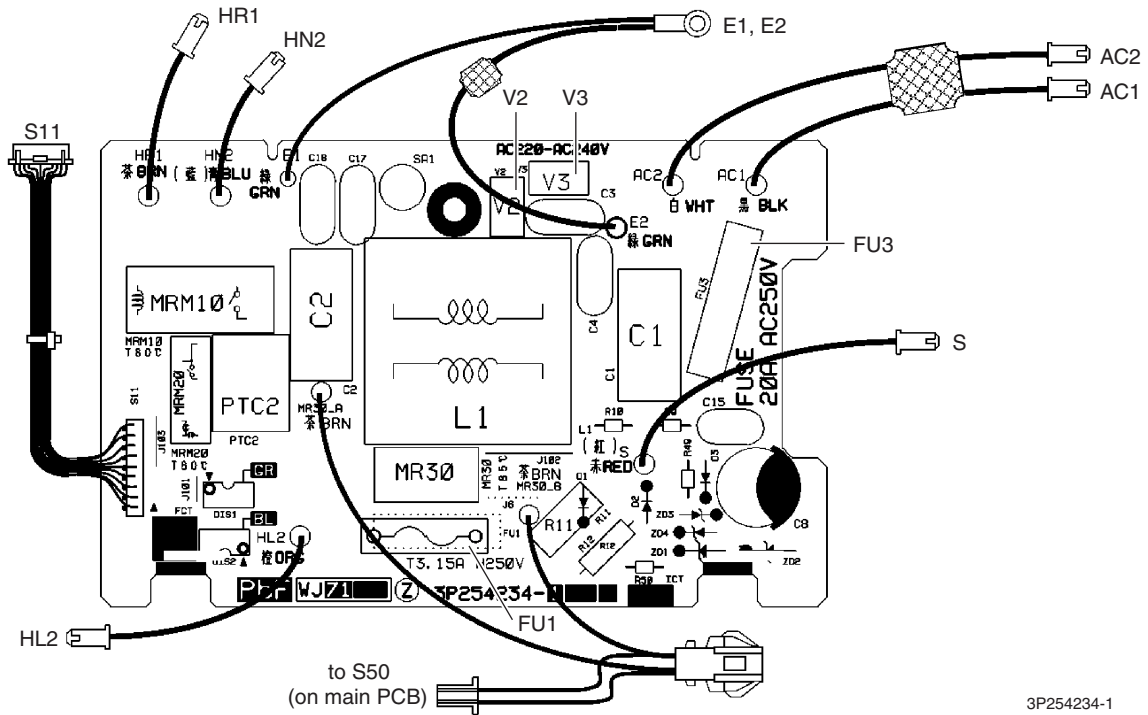

Forced Operation Button PCB (PCB3)

- 1) S110 Connector for main PCB
 - 2) SW1 Forced cooling operation ON/OFF button
- * Refer to page 104 for detail.

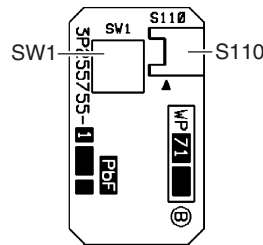

2.2 50 Class

Main PCB (PCB2)

- | | |
|-------------|--|
| 1) S10 | Connector for S11 on filter PCB |
| 2) S12 | Connector for HL4, HN4 on filter PCB |
| 3) S20 | Connector for electronic expansion valve coil |
| 4) S40 | Connector for overload protector |
| 5) S50 | Connector for magnetic relay |
| 6) S70 | Connector for fan motor |
| 7) S80 | Connector for four way valve coil |
| 8) S90 | Connector for thermistors
(outdoor temperature, outdoor heat exchanger, discharge pipe) |
| 9) HL3, HN3 | Connector for HL2, HN2 on filter PCB |
| 10) U, V, W | Terminal for compressor |
| 11) FU2 | Fuse (3.15 A, 250 V) |
| 12) LED A | LED for service monitor (green) |
| 13) V1 | Varistor |
| 14) J8 | Jumper for improvement of defrost performance |
- * Refer to page 109 for detail.

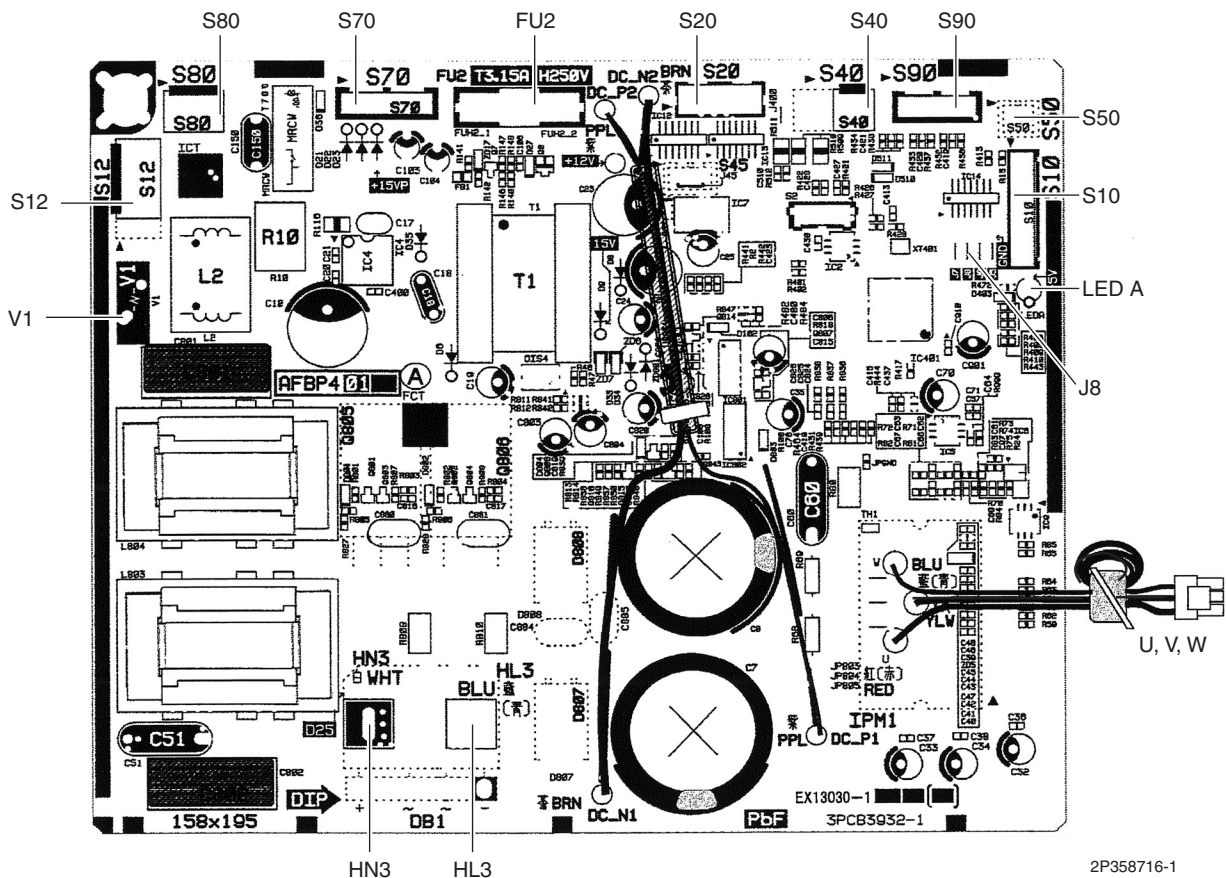

Caution

Replace the PCB if you accidentally cut the jumpers other than J8.

Jumpers are necessary for electronic circuit. Improper operation may occur if you cut any of them.

Filter PCB (PCB1)

- | | |
|----------------|--|
| 1) S11 | Connector for S10 on main PCB |
| 2) HL1, HN1, S | Connector for terminal board |
| 3) E1, E2 | Terminal for earth wire |
| 4) HL2, HN2 | Connector for HL3, HN3 on main PCB |
| 5) HL4, HN4 | Connector for S12 on main PCB |
| 6) FU1 | Fuse (3.15 A, 250 V) |
| 7) FU3 | Fuse (30 A, 250 V) |
| 8) V2, V3 | Varistor |
| 9) SW1 | Forced cooling operation ON/OFF button |
- * Refer to page 104 for detail.

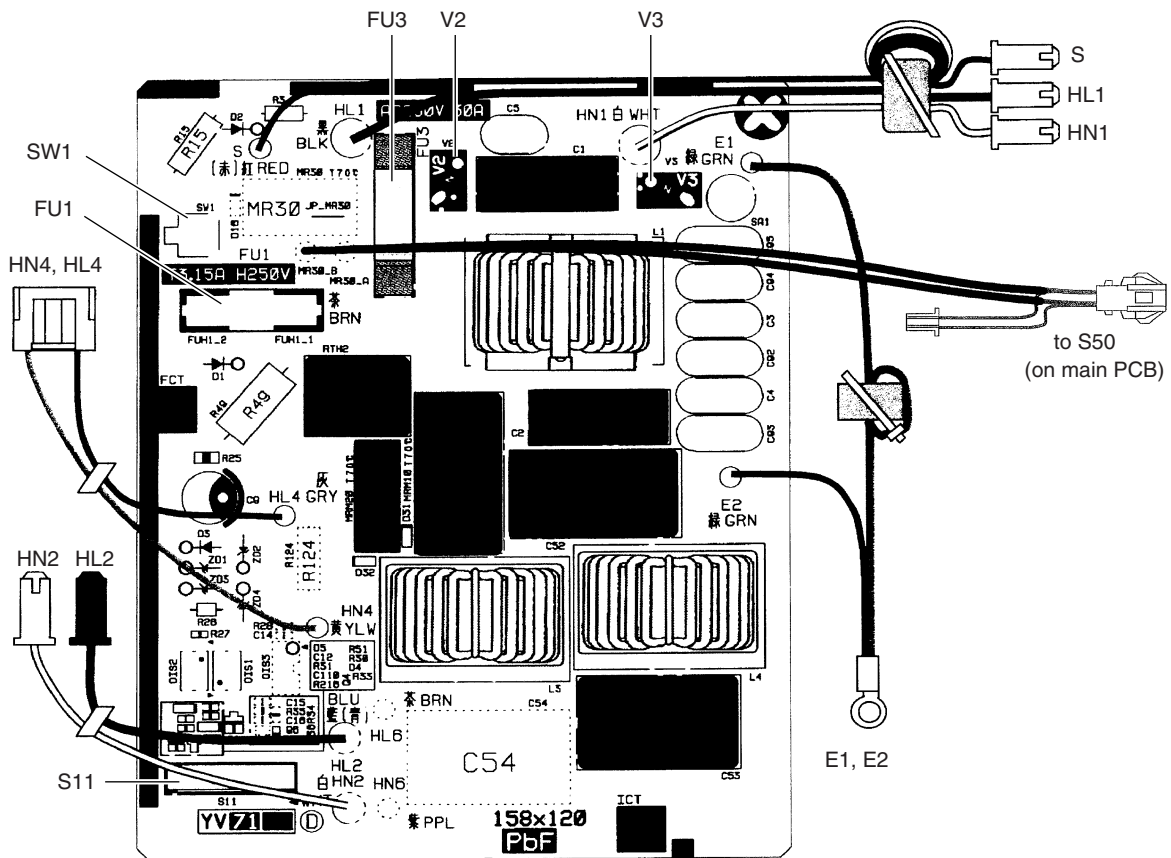

3P273862-4

Part 4

Function and Control

1. Main Functions	16
1.1 Temperature Control	16
1.2 Frequency Principle.....	16
1.3 Operation Starting Control.....	18
1.4 Airflow Direction Control.....	19
1.5 Fan Speed Control for Indoor Unit	20
1.6 Program Dry Operation	21
1.7 Automatic Operation.....	22
1.8 Thermostat Control.....	23
1.9 NIGHT SET Mode	24
1.10 ECONO Operation	24
1.11 2-Area INTELLIGENT EYE Operation	25
1.12 Inverter POWERFUL Operation	27
1.13 Multi-Monitor Lamp / TIMER Lamp	27
1.14 Clock Setting	28
1.15 WEEKLY TIMER Operation	29
1.16 Other Functions.....	35
2. Function of Thermistor	36
3. Control Specification	37
3.1 Mode Hierarchy	37
3.2 Frequency Control.....	37
3.3 Controls at Mode Changing / Start-up.....	39
3.4 Discharge Pipe Temperature Control.....	40
3.5 Input Current Control.....	41
3.6 Freeze-up Protection Control	42
3.7 Heating Peak-cut Control	42
3.8 Outdoor Fan Control.....	43
3.9 Liquid Compression Protection Function.....	43
3.10 Defrost Control	44
3.11 Electronic Expansion Valve Control	45
3.12 Malfunctions	48

1. Main Functions

1.1 Temperature Control

Definitions of Temperatures

The definitions of temperatures are classified as following.

- ◆ Room temperature: temperature of lower part of the room
- ◆ Set temperature: temperature set by remote controller
- ◆ Room thermistor temperature: temperature detected by room temperature thermistor
- ◆ Target temperature: temperature determined by microcomputer

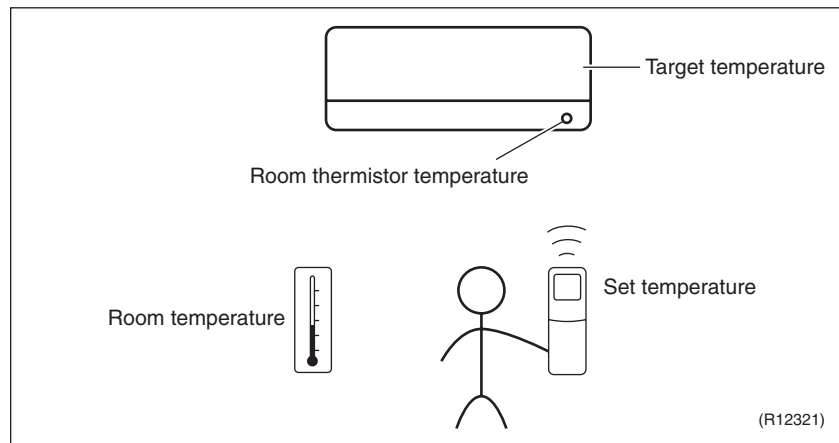

Temperature Control

The temperature of the room is detected by the room temperature thermistor. However, there is a difference between the temperature detected by room temperature thermistor and the temperature of lower part of the room, depending on the type of the indoor unit or installation condition. Practically, the temperature control is done by the target temperature appropriately adjusted for the indoor unit and the temperature detected by room temperature thermistor.

1.2 Frequency Principle

Control Parameters

The frequency of the compressor is controlled by the following 2 parameters:

- The load condition of the operating indoor unit
- The difference between the room thermistor temperature and the target temperature

The target frequency is adapted by additional parameters in the following cases:

- Frequency restrictions
- Initial settings
- Forced cooling operation

Inverter Principle

To regulate the capacity, a frequency control is needed. The inverter makes it possible to control the rotation speed of the compressor. The following table explains the inverter principle:

Phase	Description
1	The supplied AC power source is converted into the DC power source for the present.
2	The DC power source is reconverted into the three phase AC power source with variable frequency. <ul style="list-style-type: none"> ■ When the frequency increases, the rotation speed of the compressor increases resulting in an increase of refrigerant circulation. This leads to a larger amount of heat exchange per unit. ■ When the frequency decreases, the rotation speed of the compressor decreases resulting in a decrease of refrigerant circulation. This leads to a smaller amount of heat exchange per unit.

The following drawing shows a schematic view of the inverter principle:

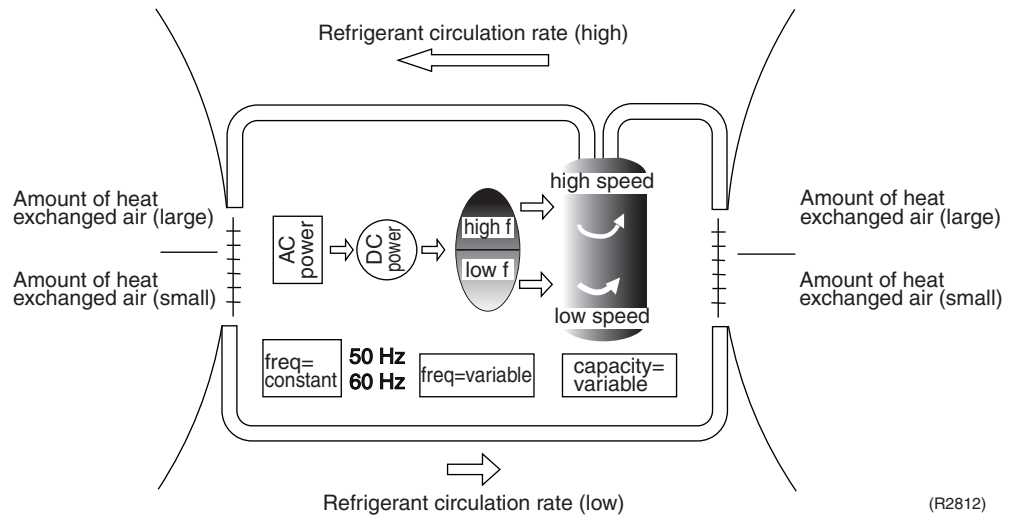

Inverter Features

The inverter provides the following features:

- The regulating capacity can be changed according to the changes in the outdoor temperature and cooling / heating load.
- Quick heating and quick cooling
The rotation speed of the compressor is increased when starting the heating (or cooling). This enables to reach the set temperature quickly.
- Even during extreme cold weather, high capacity is achieved. It is maintained even when the outdoor temperature is 2°C.
- Comfortable air conditioning
A fine adjustment is integrated to keep the room temperature constant.
- Energy saving heating and cooling
Once the set temperature is reached, the energy saving operation enables to maintain the room temperature at low power.

Frequency Limits

The following functions regulate the minimum and maximum frequency:

Frequency	Functions
Low	<ul style="list-style-type: none"> ■ Four way valve operation compensation. Refer to page 39.
High	<ul style="list-style-type: none"> ■ Compressor protection function. Refer to page 40. ■ Discharge pipe temperature control. Refer to page 40. ■ Input current control. Refer to page 41. ■ Freeze-up protection control. Refer to page 42. ■ Heating peak-cut control. Refer to page 42. ■ Defrost control. Refer to page 44.

Forced Cooling Operation

Refer to page 104 for detail.

1.3 Operation Starting Control

Outline The system carries out the following control at the beginning to conduct every functional parts properly.

Control Flow

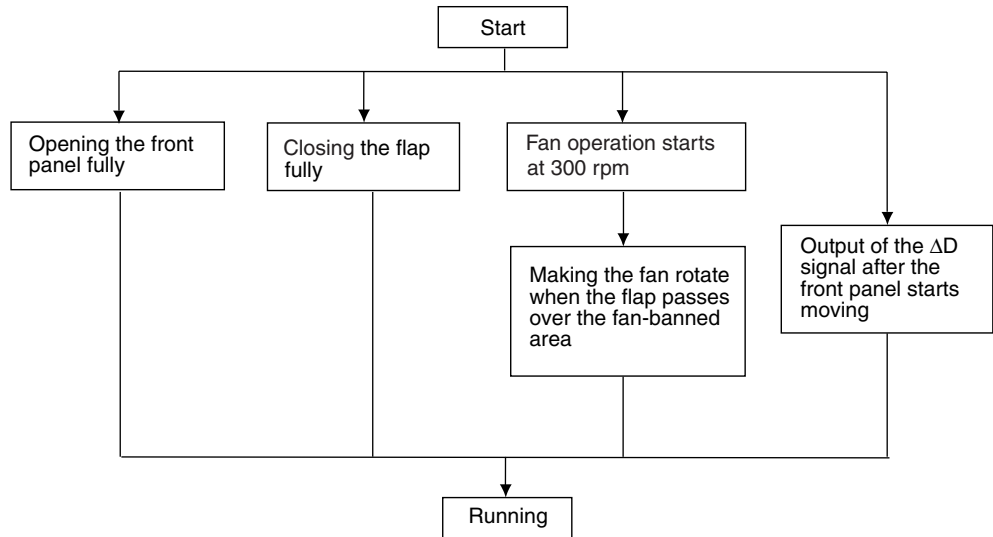

(R20133)

Timing Chart

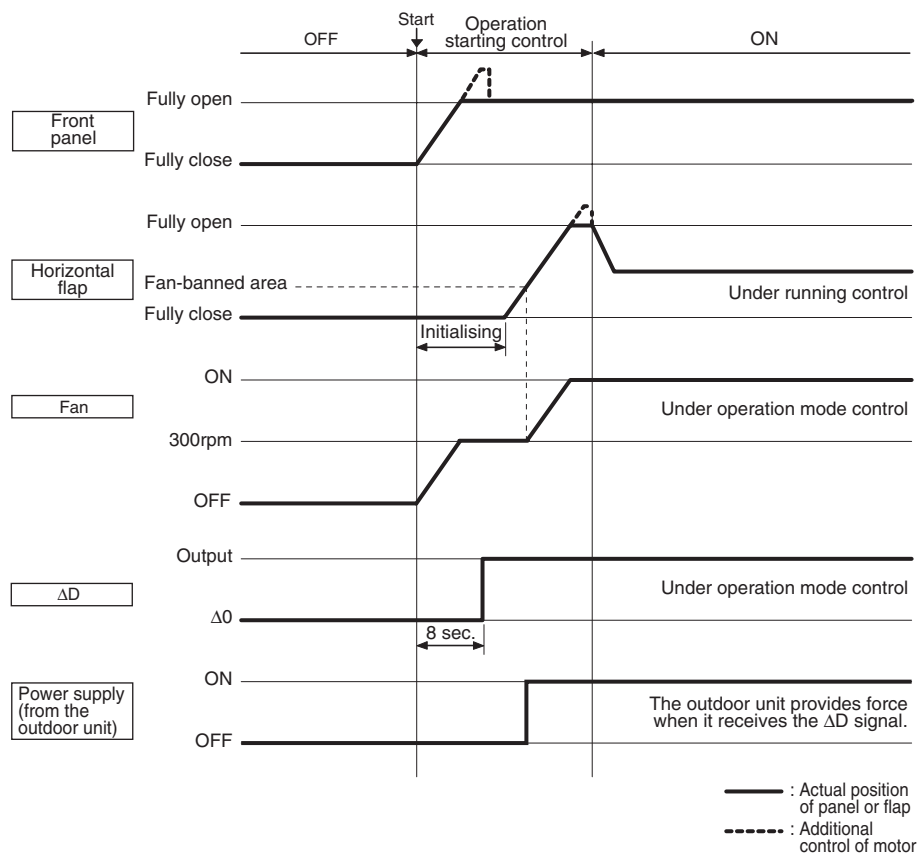

(R20134)

1.4 Airflow Direction Control

Power-Airflow Dual Flaps

The large flap sends a large volume of air downward to the floor and provides an optimum control in cooling, dry, and heating operation.

<Cooling / Dry>

During cooling or dry operation, the flap retracts into the indoor unit. Then, cool air can be blown far and distributed all over the room.

<Heating>

During heating operation, the large flap directs airflow downward to spread the warm air to the entire room.

Wide-Angle Louvers

The louvers, made of elastic synthetic resin, provide a wide range of airflow that guarantees comfortable air distribution.

Auto-Swing

The following table explains the auto-swing process for cooling, dry, heating, and fan:

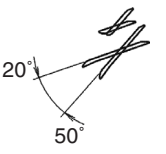
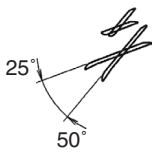
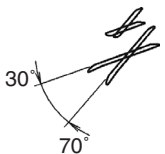
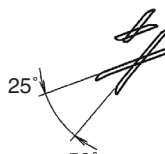
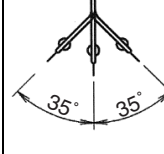
Vertical Swing (up and down)				Horizontal Swing (right and left)
Cooling	Dry	Heating	Fan	
 (R19937)	 (R19938)	 (R19939)	 (R19940)	 (R19941)

3-D Airflow

Alternative repetition of vertical and horizontal swing motions enables uniform air-conditioning of the entire room.

When the horizontal swing and vertical swing are both set to automatic operation, the airflow becomes 3-D airflow. The horizontal and vertical swing motions are alternated and the airflow direction changes in the order shown in the following diagram.

- (1) The vertical blades (louvers) move from the right to the left.
- (2) The horizontal blades (flaps) move downward.
- (3) The vertical blades (louvers) move from the left to the right.
- (4) The horizontal blades (flaps) move upward.

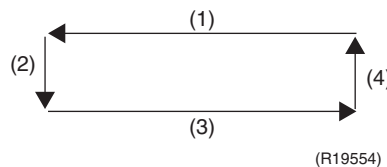

COMFORT AIRFLOW Operation

The flap is controlled not to blow the air directly at the people in the room.

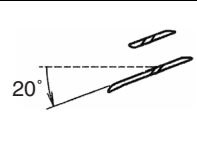
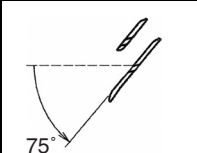
Cooling / Dry	Heating
 (R19922)	 (R19923)



1.5 Fan Speed Control for Indoor Unit

Outline

Phase control and fan speed control contains 9 steps: LLL, LL, SL, L, ML, M, MH, H, and HH. The airflow rate can be automatically controlled depending on the difference between the room thermistor temperature and the target temperature.

Automatic Fan Speed Control

In automatic fan speed operation, the step SL is not available.

Step	Cooling	Heating
LLL	 (R11681)	 (R6834)
LL		
L		
ML		
M		
MH		
H		
HH (POWERFUL)		

↔ = The airflow rate is automatically controlled within this range when the **FAN** setting button is set to automatic.

<Cooling>

The following drawing explains the principle of fan speed control for cooling.

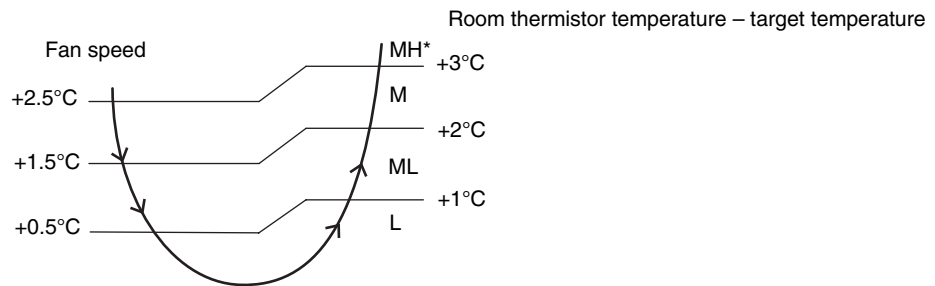

(R14588)

*The upper limit is M tap for 30 minutes from the operation start.

<Heating>

In heating operation, the fan speed is regulated according to the indoor heat exchanger temperature and the difference between the room thermistor temperature and the target temperature.

COMFORT AIRFLOW Operation

- The fan speed is controlled automatically.
- The latest command has the priority between POWERFUL and COMFORT AIRFLOW.

1.6 Program Dry Operation

Outline

Program dry operation removes humidity while preventing the room temperature from lowering. Since the microcomputer controls both the temperature and airflow rate, the temperature adjustment and **FAN** setting buttons are inoperable.

Detail

The microcomputer automatically sets the temperature and airflow rate. The difference between the room thermistor temperature at start-up and the target temperature is divided into two zones. Then, the unit operates in an appropriate capacity for each zone to maintain the temperature and humidity at a comfortable level.

Room thermistor temperature at start-up	Target temperature X	Thermostat OFF point Y	Thermostat ON point Z
24°C or more	Room thermistor temperature at start-up	$X - 2.0^{\circ}\text{C}$	$X - 0.5^{\circ}\text{C}$ or $Y + 0.5^{\circ}\text{C}$ (zone B) continues for 10 min.
23.5°C ⋮ 18°C		$X - 1.5^{\circ}\text{C}$	$X - 0.5^{\circ}\text{C}$ or $Y + 0.5^{\circ}\text{C}$ (zone B) continues for 10 min.
17.5°C ⋮	18°C	$X - 1.5^{\circ}\text{C}$	$X - 0.5^{\circ}\text{C} = 17.5^{\circ}\text{C}$ or $Y + 0.5^{\circ}\text{C}$ (zone B) continues for 10 min.

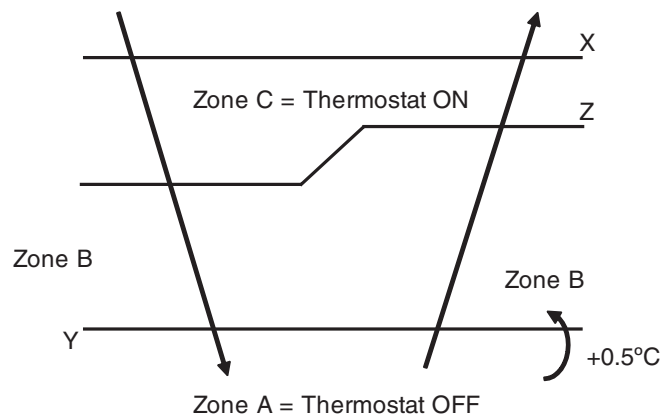

(R11581)

1.7 Automatic Operation

Outline

Automatic Cooling / Heating Function

When the automatic operation is selected with the remote controller, the microcomputer automatically determines the operation mode as cooling or heating according to the room temperature and the set temperature at start-up.

The unit automatically switches the operation mode to maintain the room temperature at the set temperature.

Detail

Ts: set temperature (set by remote controller)

Tt: target temperature (determined by microcomputer)

Tr: room thermistor temperature (detected by room temperature thermistor)

C: correction value

- The set temperature (Ts) determines the target temperature (Tt).
(Ts = 18 ~ 30°C).
- The target temperature (Tt) is calculated as;

$$Tt = Ts + C$$
 where C is the correction value.

$$C = 0^{\circ}\text{C}$$
- Thermostat ON/OFF point and operation mode switching point are as follows.
 Tr means the room thermistor temperature.
 - Heating → Cooling switching point:

$$Tr \geq Tt + 3.0^{\circ}\text{C}$$
 - Cooling → Heating switching point:

$$Tr < Tt - 2.5^{\circ}\text{C}$$
 - Thermostat ON/OFF point is the same as the ON/OFF point of cooling or heating operation.
- During initial operation
 - $Tr \geq Ts$: Cooling operation
 - $Tr < Ts$: Heating operation

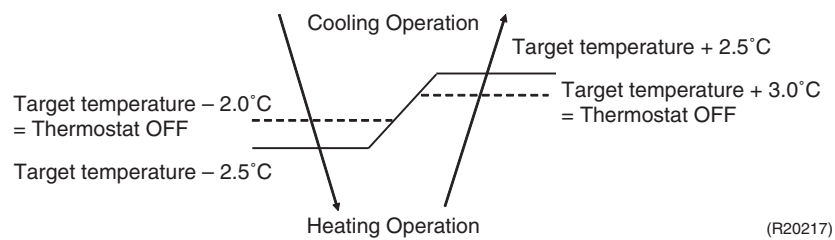

Ex: When the target temperature is 25°C

Cooling → 23.0°C: Thermostat OFF → 22.0°C: Switch to heating

Heating → 26.5°C: Thermostat OFF → 28.0°C: Switch to cooling

1.8 Thermostat Control

Outline Thermostat control is based on the difference between the room thermistor temperature and the target temperature.

Detail

Thermostat OFF Condition

- ◆ The temperature difference is in the zone A.

Thermostat ON Conditions

- ◆ The temperature difference returns to the zone C after being in the zone A.
- ◆ The system resumes from defrost control in any zones except A.
- ◆ The operation turns on in any zones except A.
- ◆ The monitoring time has passed while the temperature difference is in the zone B.
(Cooling / Dry: 10 minutes, Heating: 10 seconds)

<Cooling / Dry>

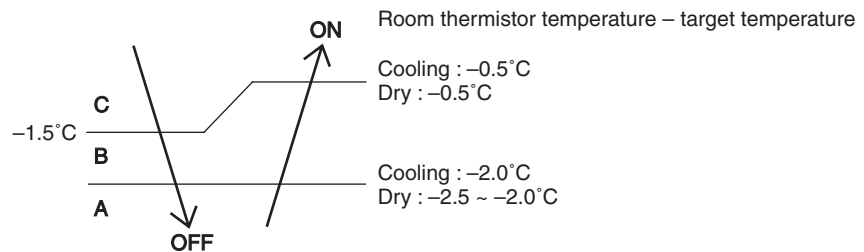

(R12319)

<Heating>

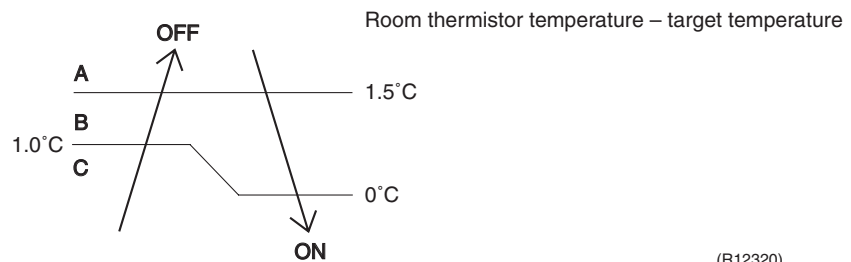

(R12320)



Refer to Temperature Control on page 16 for detail.

1.9 NIGHT SET Mode

Outline When the OFF TIMER is set, NIGHT SET Mode is automatically activated. NIGHT SET Mode keeps the airflow rate setting.

Detail NIGHT SET Mode continues operation at the target temperature for the first one hour, then automatically raises the target temperature slightly in the case of cooling, or lowers it slightly in the case of heating. This prevents excessive cooling in summer and excessive heating in winter to ensure comfortable sleeping conditions, and also conserves electricity.

<Cooling>

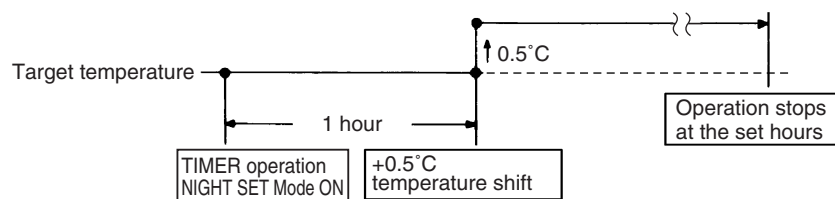

(R18917)

<Heating>

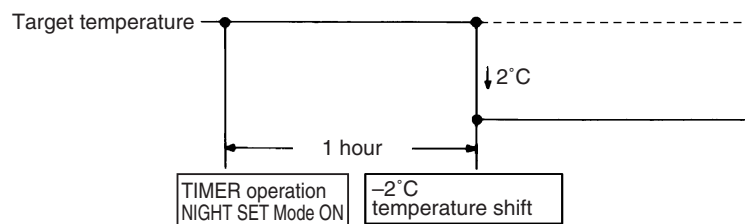

(R19386)

1.10 ECONO Operation

Outline ECONO operation reduces the maximum operating current and the power consumption. This operation is particularly convenient for energy-saving. It is also a major bonus when breaker capacity does not allow the use of multiple electrical devices and air conditioners. It can be easily activated by pushing the **ECONO** button on the wireless remote controller.

Detail

- When this function is activated, the maximum capacity also decreases.
- The remote controller can send the ECONO command when the unit is in cool or dry operation. This function can only be set when the unit is running. Pressing the **ON/OFF** button on the remote controller cancels the function.
- This function and POWERFUL operation cannot be used at the same time. The latest command has the priority.

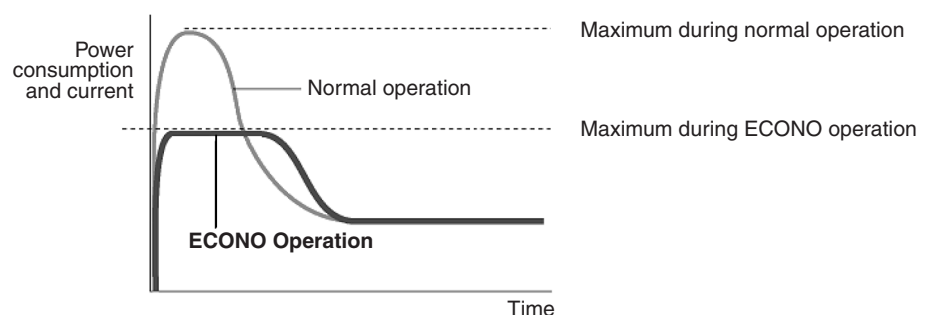

(R19427)

1.11 2-Area INTELLIGENT EYE Operation

Outline

The following functions can be performed by a motion sensor (INTELLIGENT EYE).

1. Reduction of the capacity when there is nobody in the room in order to save electricity (energy saving operation)
2. Dividing the room into plural areas and detecting existence of humans in each area.
Moving the airflow direction to the area with no human automatically to avoid direct airflow on humans.

Detail

1. Detection method of INTELLIGENT EYE

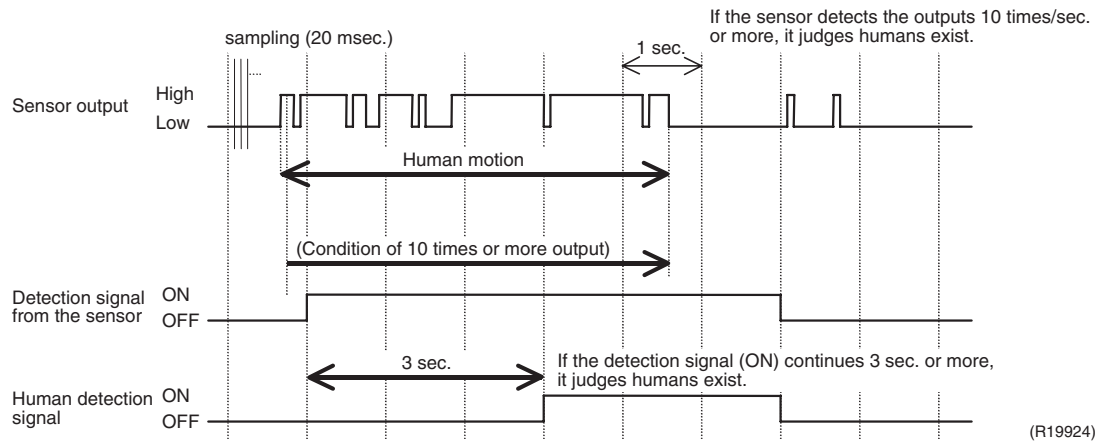

- The sensor detects human motion by receiving infrared rays and displays the pulse wave output.
- The microcomputer in the indoor unit carries out a sampling every 20 msec. and if it detects 10 cycles of the wave in one second in total, and when the ON signal continues 3 sec., it judges human is in the room as the motion signal is ON.
- 2-area INTELLIGENT EYE sensor is divided into 2 areas and detects humans in each area.
- The sensor may detect human motion with up to 20 msec. latency.

■ Image of 2-area INTELLIGENT EYE

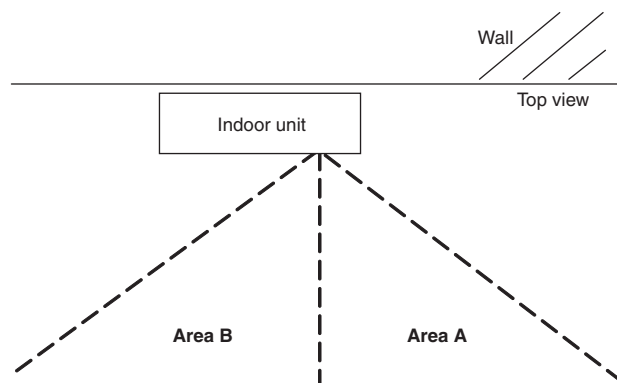

· A microcomputer judges human existence by the sensor signal from each area A and B.

(R12276)

2. The motions (in cooling)

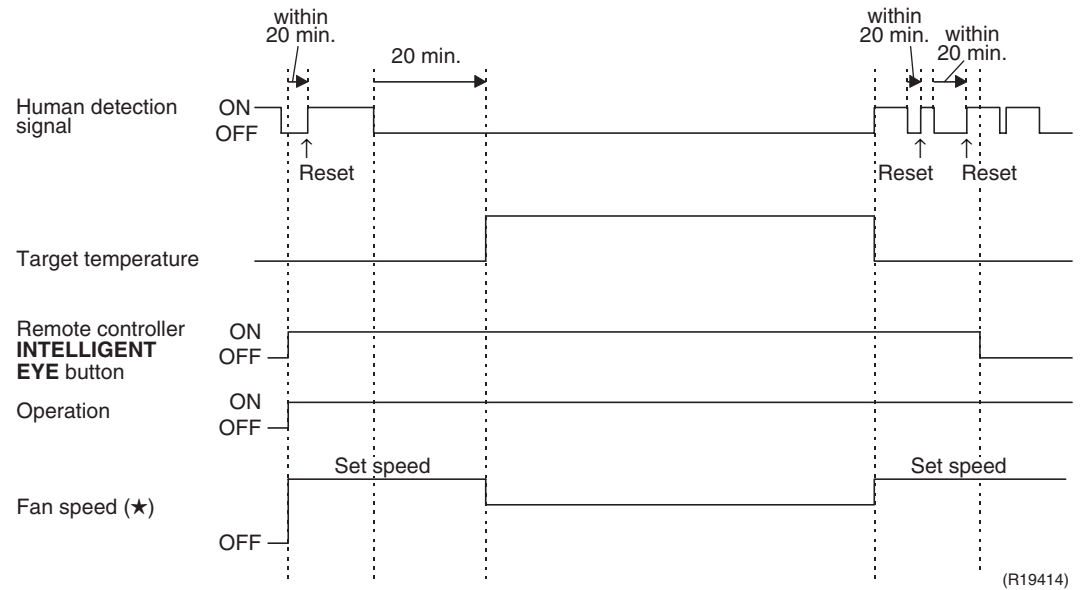

★ In FAN operation, the fan speed is reduced by 60 rpm.

- When the microcomputer does not have a signal from the sensor in 20 minutes, it judges that nobody is in the room and operates the unit at a temperature shifted from the target temperature. (cooling / dry: 1 ~ 2°C higher, heating: 2°C lower, automatic: according to the operation mode at that time.)

3. Airflow direction in 2-area INTELLIGENT EYE operation

- Detection method: The opposite area of detected area is set as the target direction.

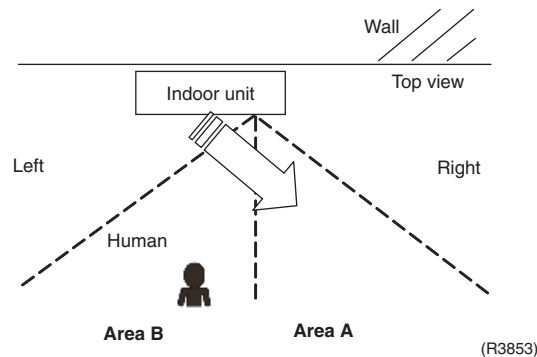

1. Detection signal ON in both area A and B: Shift the airflow direction to area B (left side)
2. Detection signal ON in area A: Shift the airflow direction to area B (left side)
3. Detection signal ON in area B: Shift the airflow direction to area A (right side)
4. Detection signal OFF in both area A and B: No change

*When the detection signal is OFF for 20 minutes in both area A and B, the unit starts energy saving operation.



Note:

For dry operation, the temperature cannot be set with a remote controller, but the target temperature is shifted internally.

1.12 Inverter POWERFUL Operation

Outline

In order to exploit the cooling and heating capacity to full extent, the air conditioner can be operated by increasing the indoor fan rotating speed and the compressor frequency.

Detail

When the **POWERFUL** button is pressed, the fan speed and target temperature are converted to the following states for 20 minutes.

Operation mode	Fan speed	Target temperature
COOL	H tap + A rpm	18°C
DRY	Dry rotating speed + A rpm	Lowered by 2.5°C
HEAT	H tap + A rpm	31°C
FAN	H tap + A rpm	—
AUTO	Same as cooling / heating in POWERFUL operation	The target temperature is kept unchanged.

A = 60 ~ 80 rpm (depending on the model)

Ex: POWERFUL operation in cooling.

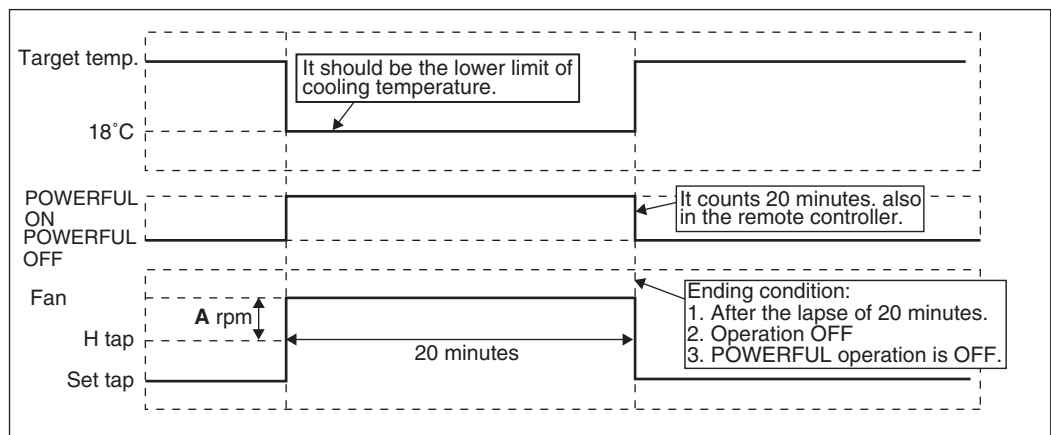

(R19177)



Note: POWERFUL Operation cannot be used together with OUTDOOR UNIT QUIET Operation.

1.13 Multi-Monitor Lamp / TIMER Lamp

Current operation mode is displayed in color of the lamp of the indoor unit. Operating status can be monitored even in automatic operation in accordance with the actual operation mode.

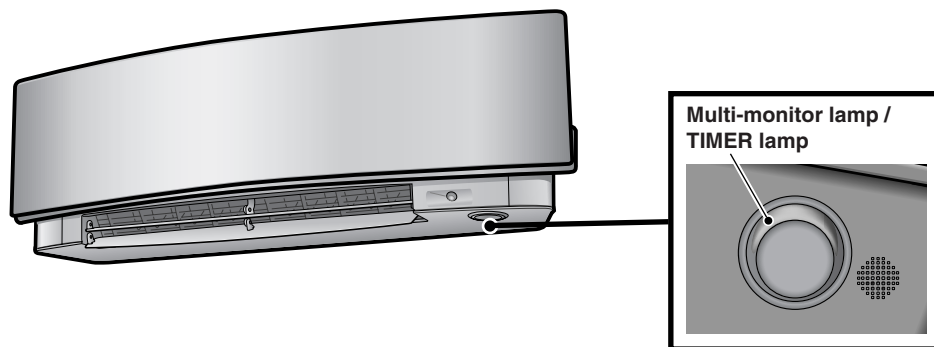

(R19925)

The lamp color changes according to the operation.

- * AUTO Red / Blue
- * DRY Green
- * COOL Blue
- * HEAT Red
- * FAN White
- * TIMER Orange

Brightness Setting

Each time the **Brightness** button on the remote controller is pressed, the brightness of the multi-monitor lamp changes to high, low, or off.

1.14 Clock Setting

ARC466 Series

The clock can be set by taking the following steps:

1. Press the **CLOCK** button.
→ 0:00 is displayed and **MON** and ☉ blink.
2. Press the **SELECT ▲** or **▼** button to set the clock to the current day of the week.
3. Press the **CLOCK** button.
→ ☉ blinks.
4. Press the **SELECT ▲** or **▼** button to adjust the clock to the present time.
Holding down the **SELECT ▲** or **▼** button increases or decreases the time display rapidly.
5. Press the **CLOCK** button to set the clock. (Point the remote controller at the indoor unit when pressing the button.)
→ : blinks and clock setting is completed.

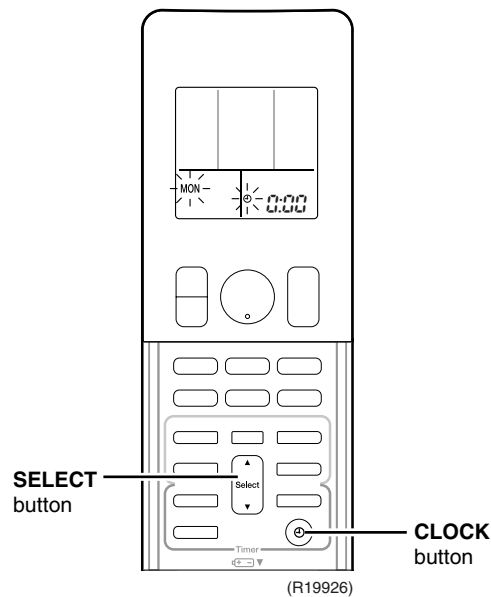

1.15 WEEKLY TIMER Operation

Outline

Up to 4 timer settings can be saved for each day of the week (up to 28 settings in total). The 3 items: ON/OFF, temperature, and time can be set.

Detail

■ Setting example of the WEEKLY TIMER

The same timer settings are made for the week from Monday through Friday while different timer settings are made for the weekend.

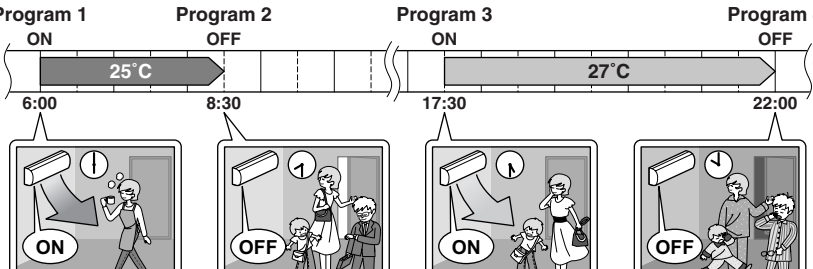
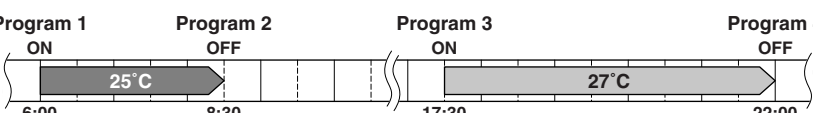
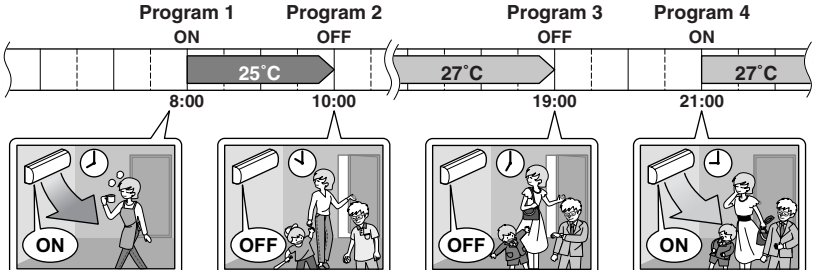
[Monday]	<p>Make timer settings up to programs 1-4.</p> <p>Program 1 ON Program 2 OFF Program 3 ON Program 4 OFF</p> 
[Tuesday] to [Friday]	<p>Use the copy mode to make settings for Tuesday to Friday, because these settings are the same as those for Monday.</p> <p>Program 1 ON Program 2 OFF Program 3 ON Program 4 OFF</p> 
[Saturday]	No timer settings
[Sunday]	<p>Make timer settings up to programs 1-4.</p> <p>Program 1 ON Program 2 OFF Program 3 OFF Program 4 ON</p> 

- Up to 4 reservations per day and 28 reservations per week can be set in the WEEKLY TIMER. The effective use of the copy mode ensures ease of making reservations.
- The use of ON-ON-ON-ON settings, for example, makes it possible to schedule operating mode and set temperature changes. Furthermore, by using OFF-OFF-OFF-OFF settings, only the turn off time of each day can be set. This will turn off the air conditioner automatically if the user forgets to turn it off.

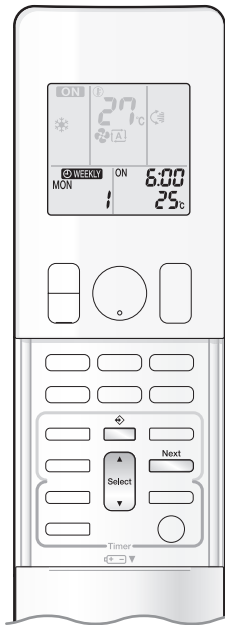

■ To use WEEKLY TIMER operation

Setting mode

- Make sure the day of the week and time are set. If not, set the day of the week and time.

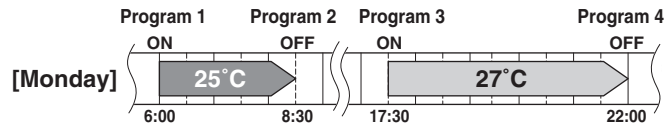

Setting Displays

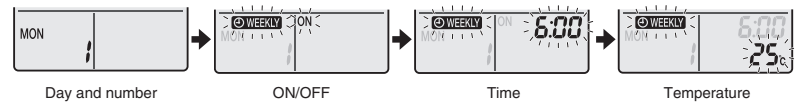

1. Press .

- The day of the week and the reservation number of the current day will be displayed.
- 1 to 4 settings can be made per day.

2. Press to select the desired day of the week and reservation number.

- Pressing  changes the reservation number and the day of the week.

3. Press .

- The day of the week and reservation number will be set.
- "WEEKLY" and "ON" blink.

4. Press to select the desired mode.

- Pressing  changes "ON" or "OFF" setting in sequence.

Pressing  alternates the following items appearing on the LCD in rotational sequence.



- In case the reservation has already been set, selecting "blank" deletes the reservation.
- Go to step 9 if "blank" is selected.
- To return to the day of the week and reservation number setting, press .

5. Press .

- The ON/OFF TIMER mode will be set.
- "WEEKLY" and the time blink.

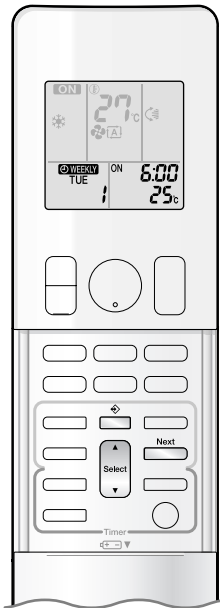

6. Press to select the desired time.

- The time can be set between 0:00 and 23:50 in 10 minute intervals.
- To return to the ON/OFF TIMER mode setting, press .
- Go to step 9 when setting the OFF TIMER.

7. Press .

- The time will be set.
- “ WEEKLY” and the temperature blink.

8. Press to select the desired temperature.

- The temperature can be set between 10°C and 32°C.
COOL or AUTO: The unit operates at 18°C even if it is set at 10°C to 17°C.
HEAT or AUTO: The unit operates at 30°C even if it is set at 31°C to 32°C.
- To return to the time setting, press .
- The set temperature is only displayed when the mode setting is on.

9. Press .

- Be sure to direct the remote controller toward the indoor unit and check for a receiving tone and flashing of the multi-monitor lamp.
- The temperature and time are set while in ON TIMER operation, and the time is set while in OFF TIMER operation.
- The next reservation screen will appear.
- To continue further settings, repeat the procedure from step 4.
- The multi-monitor lamp blinks twice.
The TIMER lamp periodically lights orange.
The multi-monitor lamp will not blink orange if all the reservation settings are deleted.

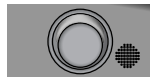

Display

10. Press to complete the setting.

- “ WEEKLY” is displayed on the LCD and WEEKLY TIMER operation is activated.
- A reservation made once can be easily copied and the same settings used for another day of the week. Refer to “Copy mode”.

NOTE

■ Notes on WEEKLY TIMER operation

- Do not forget to set the clock on the remote controller first.
- The day of the week, ON/OFF TIMER mode, time and set temperature (only for ON TIMER mode) can be set with WEEKLY TIMER.
Other settings for ON TIMER are based on the settings just before the operation.
- Both WEEKLY TIMER and ON/OFF TIMER operation cannot be used at the same time. The ON/OFF TIMER operation has priority if it is set while WEEKLY TIMER is still active. The WEEKLY TIMER will go into standby state, and “ WEEKLY” will disappear from the LCD. When ON/OFF TIMER is up, the WEEKLY TIMER will automatically become active.
- Shutting off the circuit breaker, power failure, and other similar events will render operation of the indoor unit's internal clock inaccurate.
Reset the clock.

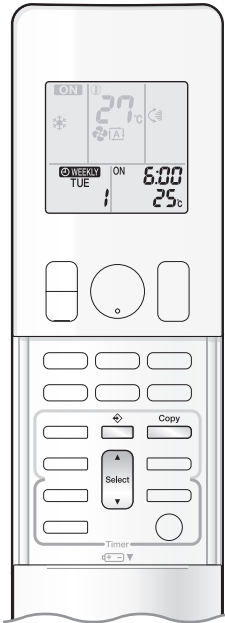

Copy mode

- A reservation made once can be copied to another day of the week. The whole reservation of the selected day of the week will be copied.

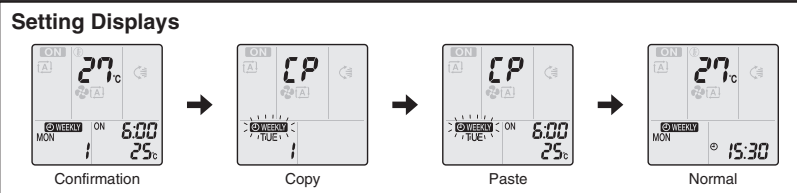
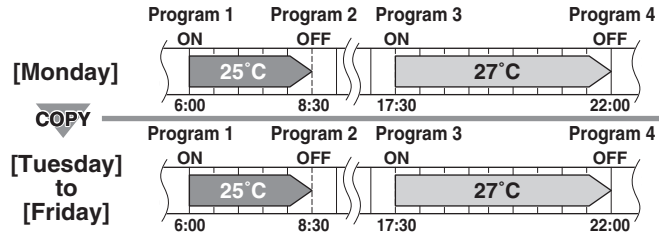

1. Press .
2. Press to confirm the day of the week to be copied.
3. Press .
 - The whole reservation of the selected day of the week will be copied.
4. Press to select the destination day of the week.
5. Press .
 - Be sure to direct the remote controller toward the indoor unit and check for a receiving tone and flashing the multi-monitor lamp.
 - The reservation will be copied to the selected day of the week. The whole reservation of the selected day of the week will be copied.
 - To continue copying the settings to other days of the week, repeat step 4 and step 5.
 - The multi-monitor lamp blinks twice. The TIMER lamp periodically lights orange.
6. Press to complete the setting.
 - "WEEKLY" is displayed on the LCD and WEEKLY TIMER operation is activated.

NOTE

■ Note on copy mode

- The entire reservation of the source day of the week is copied in the copy mode.

In the case of making a reservation change for any day of the week individually after copying the content of weekly reservations, press and change the settings in the steps of "Setting mode".

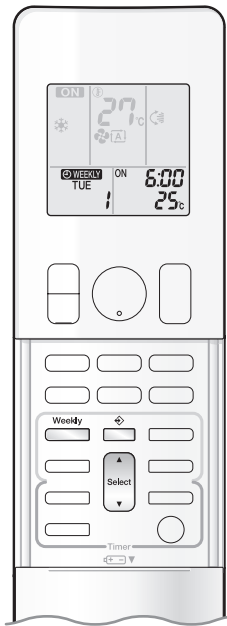

■ Confirming a reservation

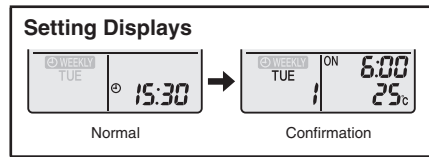

- The reservation can be confirmed.



1. Press .

- The day of the week and the reservation number of the current day will be displayed.



2. Press to select the day of the week and the reservation number to be confirmed.

- Pressing  displays the reservation details.
- To change the confirmed reserved settings, select the reservation number and press . The mode is switched to setting mode. Go to setting mode step 2.

3. Press to exit confirming mode.

■ To deactivate WEEKLY TIMER operation

Press  while “ WEEKLY” is displayed on the LCD.

- The “ WEEKLY” will disappear from the LCD.
- The TIMER lamp goes off.
- To reactivate the WEEKLY TIMER operation, press  again.
- If a reservation deactivated with  is activated once again, the last reservation mode will be used.

CAUTION

- If not all the reservation settings are reflected, deactivate the WEEKLY TIMER operation once. Then press  again to reactivate the WEEKLY TIMER operation.

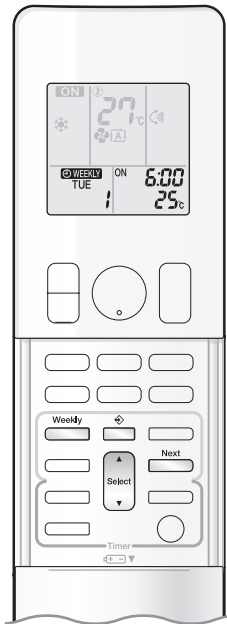

■ To delete reservations

The individual reservation

1. Press .

- The day of the week and the reservation number will be displayed.

2. Press  to select the day of the week and the reservation number to be deleted.

3. Press .

- "WEEKLY" and "ON" or "OFF" blink.

4. Press  and select "blank".

- Pressing  changes ON/OFF TIMER mode.

- Pressing  alternates the following items appearing on the LCD in rotational sequence.
- Selecting "blank" will cancel any reservation you may have.



5. Press .

- The selected reservation will be deleted.

6. Press .

- If there are still other reservations, WEEKLY TIMER operation will be activated.

The reservations for each day of the week

- This function can be used for deleting reservations for each day of the week.
- It can be used while confirming or setting reservations.

1. Press  to select the day of the week to be deleted.

2. Hold  for about 5 seconds.

- The reservation of the selected day of the week will be deleted.

All reservations

Hold  for about 5 seconds while in normal display.

- Be sure to direct the remote controller toward the indoor unit and check for a receiving tone.
- This operation is not effective while WEEKLY TIMER is being set.
- All reservations will be deleted.

1.16 Other Functions

1.16.1 Hot-Start Function

In order to prevent the cold air blast that normally occurs when heating operation is started, the temperature of the indoor heat exchanger is detected, and the airflow is either stopped or significantly weakened resulting in comfortable heating.



Note: The cold air blast is prevented using similar control when defrost control starts or when the thermostat is turned ON.

1.16.2 Signal Receiving Sign

When the indoor unit receives a signal from the remote controller, the unit emits a signal receiving sound.

1.16.3 Indoor Unit ON/OFF Button

An **ON/OFF** button is provided on the display of the unit.

- Press the **ON/OFF** button once to start operation. Press once again to stop it.
- The **ON/OFF** button is useful when the remote controller is missing or the battery has run out.
- The operation mode refers to the following table.

Operation mode	Temperature setting	Airflow rate
AUTO	25°C	Automatic

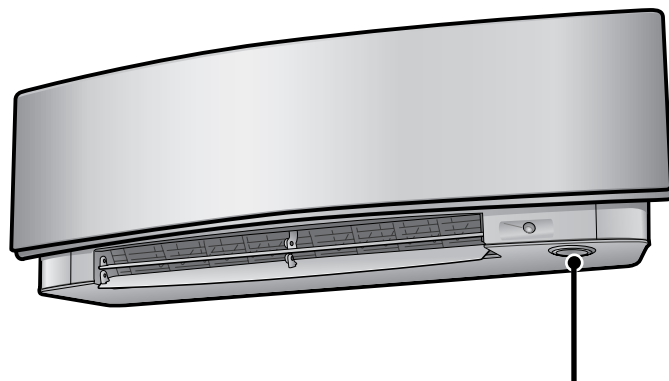

Indoor unit **ON/OFF** button

(R19927)

<Forced cooling operation>

Forced cooling operation can be started by pressing the **ON/OFF** button for 5 to 9 seconds while the unit is not operating.

Refer to page 104 for detail.



Note: When the **ON/OFF** button is pressed for 10 seconds or more, the forced cooling operation is stopped.

1.16.4 Auto-restart Function

If a power failure (including one for just a moment) occurs during the operation, the operation restarts automatically when the power is restored in the same condition as before the power failure.



Note: It takes 3 minutes to restart the operation because the 3-minute standby function is activated.

2. Function of Thermistor

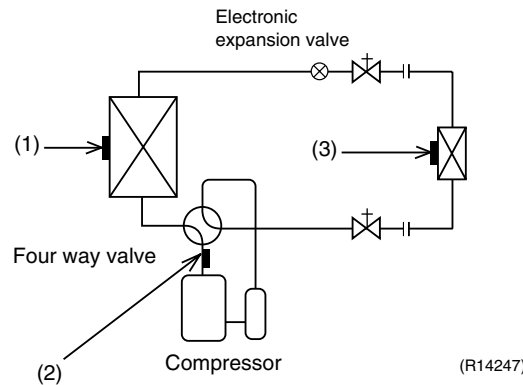

(1) Outdoor Heat Exchanger Thermistor

1. The outdoor heat exchanger thermistor is used for controlling the target discharge pipe temperature. The system sets the target discharge pipe temperature according to the outdoor and indoor heat exchanger temperature, and controls the electronic expansion valve opening so that the target discharge pipe temperature can be obtained.
2. In cooling operation, the outdoor heat exchanger thermistor is used for detecting the disconnection of the discharge pipe thermistor. When the discharge pipe temperature drops below the outdoor heat exchanger temperature by more than a certain value, the discharge pipe thermistor is judged as disconnected.
3. In cooling operation, the outdoor heat exchanger thermistor is used for high pressure protection.

(2) Discharge Pipe Thermistor

1. The discharge pipe thermistor is used for controlling discharge pipe temperature. If the discharge pipe temperature (used in place of the inner temperature of the compressor) rises abnormally, the operating frequency becomes lower or the operation halts.
2. The discharge pipe thermistor is used for detecting disconnection of the discharge pipe thermistor.

(3) Indoor Heat Exchanger Thermistor

1. The indoor heat exchanger thermistor is used for controlling the target discharge pipe temperature. The system sets the target discharge pipe temperature according to the outdoor and indoor heat exchanger temperature, and controls the electronic expansion valve opening so that the target discharge pipe temperature can be obtained.
2. In cooling operation, the indoor heat exchanger thermistor is used for freeze-up protection control. If the indoor heat exchanger temperature drops abnormally, the operating frequency becomes lower or the operation halts.
3. In heating operation, the indoor heat exchanger thermistor is used for detecting the disconnection of the discharge pipe thermistor. When the discharge pipe temperature drops below the indoor heat exchanger temperature by more than a certain value, the discharge pipe thermistor is judged as disconnected.

3. Control Specification

3.1 Mode Hierarchy

Outline

The air conditioner control has normal operation mode, forced operation mode, and power transistor test mode for installation and servicing.

Detail

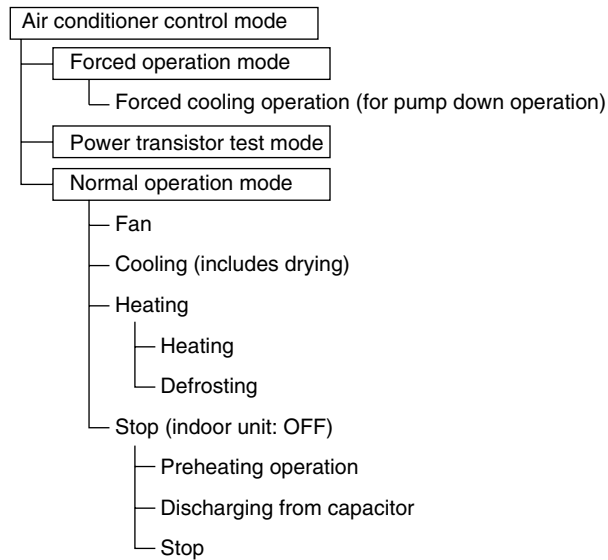

(R19522)



Note: Unless specified otherwise, a dry operation command is regarded as cooling operation.

3.2 Frequency Control

Outline

The compressor frequency is determined according to the difference between the room thermistor temperature and the target temperature.

When the shift of the frequency is less than zero ($\Delta F < 0$) by PI control, the target frequency is used as the command frequency.

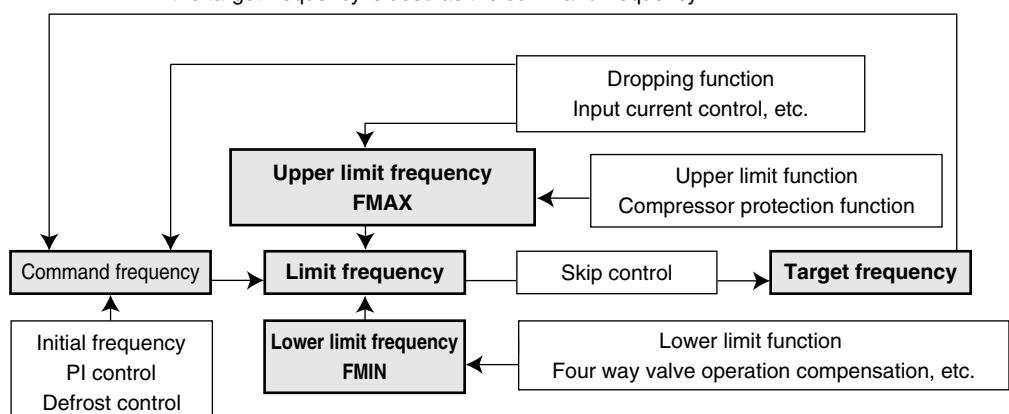

(R18023)

Detail

1. Determine command frequency

Command frequency is determined in the following order of priority.

1. Limiting defrost control time
2. Forced cooling
3. Indoor frequency command

2. Determine upper limit frequency

The minimum value is set as an upper limit frequency among the frequency upper limits of the following functions:

Compressor protection, input current, discharge pipe temperature, heating peak-cut, freeze-up protection, defrost.

3. Determine lower limit frequency

The maximum value is set as a lower limit frequency among the frequency lower limits of the following functions:

Four way valve operation compensation, draft prevention, pressure difference upkeep.

4. Determine prohibited frequency

There is a certain prohibited frequency such as a power supply frequency.

Initial Frequency

When starting the compressor, the frequency is initialized according to the ΔD value and the Q value of the indoor unit.

< ΔD signal: Indoor Frequency Command>

The difference between the room thermistor temperature and the target temperature is taken as the ΔD signal and is used for frequency command

Temperature difference	ΔD signal	Temperature difference	ΔD signal	Temperature difference	ΔD signal	Temperature difference	ΔD signal
-2.0	*OFF	0	4	2.0	8	4.0	C
-1.5	1	0.5	5	2.5	9	4.5	D
-1.0	2	1.0	6	3.0	A	5.0	E
-0.5	3	1.5	7	3.5	B	5.5	F

*OFF = Thermostat OFF

<Q value>

Q value is the indoor unit output determined from indoor heat exchanger volume and airflow rate set by remote controller.

PI Control**1. P control**

The ΔD value is calculated in each sampling time (15 ~ 20 seconds), and the frequency is adjusted according to its difference from the frequency previously calculated.

2. I control

If the operating frequency does not change for more than a certain fixed time, the frequency is adjusted according to the ΔD value.

When the ΔD value is low, the frequency is lowered.

When the ΔD value is high, the frequency is increased.

3. Frequency control when other controls are functioning

- ◆ When frequency is dropping;
Frequency control is carried out only when the frequency drops.
- ◆ For controlling lower limit;
Frequency control is carried out only when the frequency rises.

4. Upper and lower limit of frequency by PI control

The frequency upper and lower limits are set according to the command of the indoor unit.

When the indoor or outdoor unit quiet operation command comes from the indoor unit, the upper limit frequency is lower than the usual setting.

3.3 Controls at Mode Changing / Start-up

3.3.1 Preheating Control

Outline The inverter operation in open phase starts with the conditions of the preheating command from the indoor unit, the outdoor temperature, and the discharge pipe temperature.

Detail Outdoor temperature $\geq A^{\circ}\text{C}$ → Control I
Outdoor temperature $< A^{\circ}\text{C}$ → Control II

Control I

- ◆ ON condition
Discharge pipe temperature $< B^{\circ}\text{C}$
- ◆ OFF condition
Discharge pipe temperature $> C^{\circ}\text{C}$
Radiation fin temperature $\geq 90^{\circ}\text{C}$

Control II

- ◆ ON condition
Discharge pipe temperature $< D^{\circ}\text{C}$
- ◆ OFF condition
Discharge pipe temperature $> E^{\circ}\text{C}$
Radiation fin temperature $\geq 90^{\circ}\text{C}$

A ($^{\circ}\text{C}$)	B ($^{\circ}\text{C}$)	C ($^{\circ}\text{C}$)	D ($^{\circ}\text{C}$)	E ($^{\circ}\text{C}$)
-2.5	0	2	10	12

3.3.2 Four Way Valve Switching

Outline In heating operation, current is conducted, and in cooling operation and defrost control, current is not conducted. In order to eliminate the switching sound as the four way valve coil switches from ON to OFF when the heating is stopped, the OFF delay switch of the four way valve is carried out.

Detail **OFF delay switch of four way valve**
The four way valve coil is energized for 150 ~ 160 seconds after the operation is stopped.

3.3.3 Four Way Valve Operation Compensation

Outline At the beginning of operation as the four way valve is switched, the pressure difference to activate the four way valve is acquired when the output frequency is higher than a certain fixed frequency, for a certain fixed time.

Detail **Starting Conditions**

1. When the compressor starts and the four way valve switches from OFF to ON
2. When the four way valve switches from ON to OFF during operation
3. When the compressor starts after resetting
4. When the compressor starts after the fault of four way valve switching

The lower limit of frequency keeps **A** Hz for **B** seconds with any conditions 1 through 4 above.

	20/25/35 class		50 class	
	Cooling	Heating	Cooling	Heating
A (Hz)	68	66	48	
B (seconds)	45		70	

3.3.4 3-minute Standby

Turning on the compressor is prohibited for 3 minutes after turning it off.
(The function is not activated when defrosting.)

3.3.5 Compressor Protection Function

When turning the compressor from OFF to ON, the upper limit of frequency is set as follows.
(The function is not activated when defrosting.)

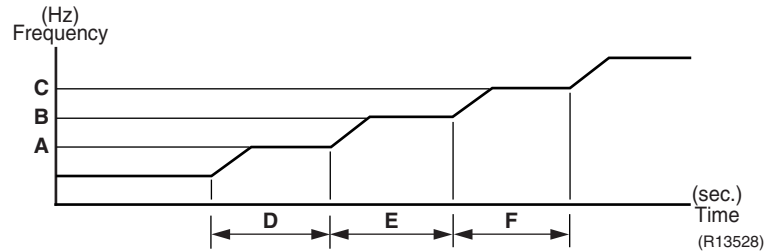

	20/25/35 class	50 class
A (Hz)	48	55
B (Hz)	64	70
C (Hz)	88	85
D (seconds)	240	120
E (seconds)	360	200
F (seconds)	180	470

3.4 Discharge Pipe Temperature Control

Outline

The discharge pipe temperature is used as the internal temperature of the compressor. If the discharge pipe temperature rises above a certain level, the upper limit of frequency is set to keep the discharge pipe temperature from rising further.

Detail

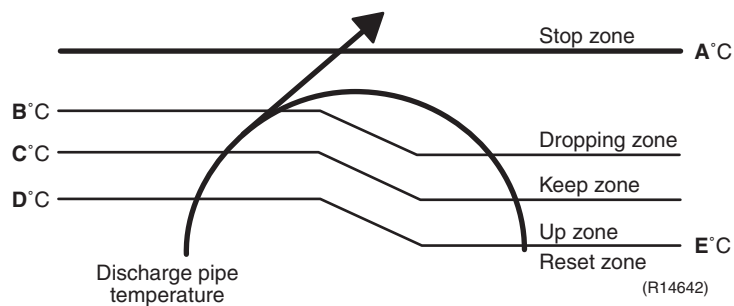

Zone	Control
Stop zone	When the temperature reaches the stop zone, the compressor stops.
Dropping zone	The upper limit of frequency decreases.
Keep zone	The upper limit of frequency is kept.
Up zone	The upper limit of frequency increases.
Reset zone	The upper limit of frequency is canceled.

	20/25/35 class	50 class
A (°C)	110	110
B (°C)	105	103
C (°C)	101	101.5
D (°C)	99	100
E (°C)	97	95

3.5 Input Current Control

Outline

The microcomputer calculates the input current while the compressor is running, and sets the frequency upper limit based on the input current.

In case of heat pump models, this control is the upper limit control of frequency and takes priority over the lower limit control of four way valve operation compensation.

Detail

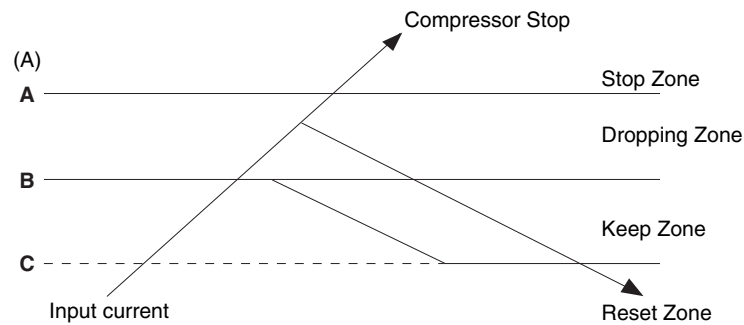

(R14643)

Frequency control in each zone

Stop zone

- ◆ After 2.5 seconds in this zone, the compressor is stopped.

Dropping zone

- ◆ The upper limit of the compressor frequency is defined as operation frequency – 2 Hz.
- ◆ After this, the output frequency is lowered by 2 Hz every second until it reaches the keep zone.

Keep zone

- ◆ The present maximum frequency goes on.

Reset zone

- ◆ Limit of the frequency is canceled.

	20/25 class		35 class		50 class	
	Cooling	Heating	Cooling	Heating	Cooling	Heating
A (A)	9.25		9.25		20.0	
B (A)	6.25	7.5	8.25		12.0	
C (A)	5.5	6.75	7.5		11.0	

Limitation of current dropping and stop value according to the outdoor temperature

- ◆ The current drops when outdoor temperature becomes higher than a certain level (depending on the model).

3.6 Freeze-up Protection Control

During cooling operation, the signal sent from the indoor unit determines the frequency upper limit and prevents freezing of the indoor heat exchanger. (The signal from the indoor unit is divided into zones.)

The operating frequency limitation is judged with the indoor heat exchanger temperature.

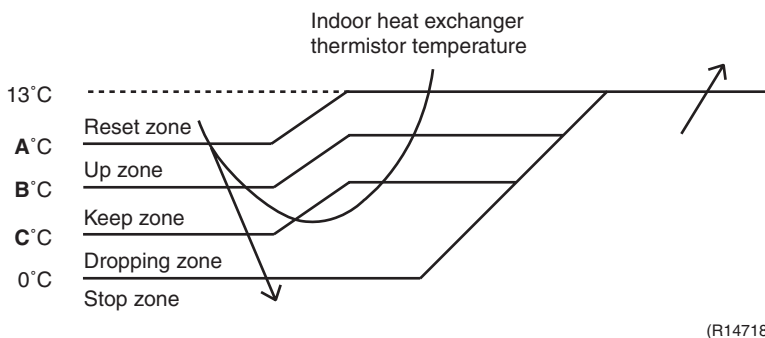

(R14718)

A (°C)	B (°C)	C (°C)
9.5	7.5	5.5

3.7 Heating Peak-cut Control

During heating operation, the indoor heat exchanger temperature determines the frequency upper limit to prevent abnormal high pressure.

The operating frequency limitation is judged with the indoor heat exchanger temperature.

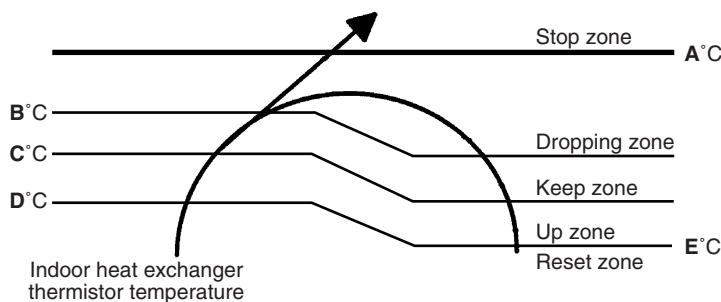

(R14645)

Zone	Control
Stop zone	When the temperature reaches the stop zone, the compressor stops.
Dropping zone	The upper limit of frequency decreases.
Keep zone	The upper limit of frequency is kept.
Up zone	The upper limit of frequency increases.
Reset zone	The upper limit of frequency is canceled.

	20/25/35 class	50 class
A (°C)	65	65
B (°C)	56	56
C (°C)	53	55
D (°C)	51	53
E (°C)	46	51

3.8 Outdoor Fan Control

1. Fan ON control to cool down the electrical box

The outdoor fan is turned ON when the electrical box temperature is high while the compressor is OFF.

2. Fan OFF control during defrosting

The outdoor fan is turned OFF during defrosting.

3. Fan OFF delay when stopped

The outdoor fan is turned OFF 60 seconds after the compressor stops.

4. Fan speed control for pressure difference upkeep

The rotation speed of the outdoor fan is controlled for keeping the pressure difference during cooling operation with low outdoor temperature.

- ◆ When the pressure difference is low, the rotation speed of the outdoor fan is reduced.
- ◆ When the pressure difference is high, the rotation speed of the outdoor fan is controlled as well as normal operation.

5. Fan speed control during forced cooling operation

The outdoor fan is controlled as well as normal operation during forced cooling operation.

6. Fan speed control during POWERFUL operation

The rotation speed of the outdoor fan is increased during POWERFUL operation.

7. Fan speed control during indoor / outdoor unit quiet operation

The rotation speed of the outdoor fan is reduced by the command of the indoor / outdoor unit quiet operation.

8. Fan ON/OFF control when operation starts / stops

The outdoor fan is turned ON when the operation starts. The outdoor fan is turned OFF when the operation stops.

3.9 Liquid Compression Protection Function

Outline

In order to increase the dependability of the compressor, the compressor is stopped according to the outdoor temperature and temperature of the outdoor heat exchanger.

Detail

Operation stops depending on the outdoor temperature.

Compressor turns off under the conditions that the system is in cooling operation and outdoor temperature is below -12°C .

3.10 Defrost Control

Outline

Defrosting is carried out by the cooling cycle (reverse cycle). The defrosting time or outdoor heat exchanger temperature must be more than a certain value to finish defrosting.

Detail

Conditions for Starting Defrost

- The starting conditions are determined with the outdoor temperature and the outdoor heat exchanger temperature.
- The system is in heating operation.
- The compressor operates for 6 minutes.
- More than **A** minutes of accumulated time have passed since the start of the operation, or ending the previous defrosting.

Conditions for Canceling Defrost

The judgment is made with the outdoor heat exchanger temperature. (**B**°C)

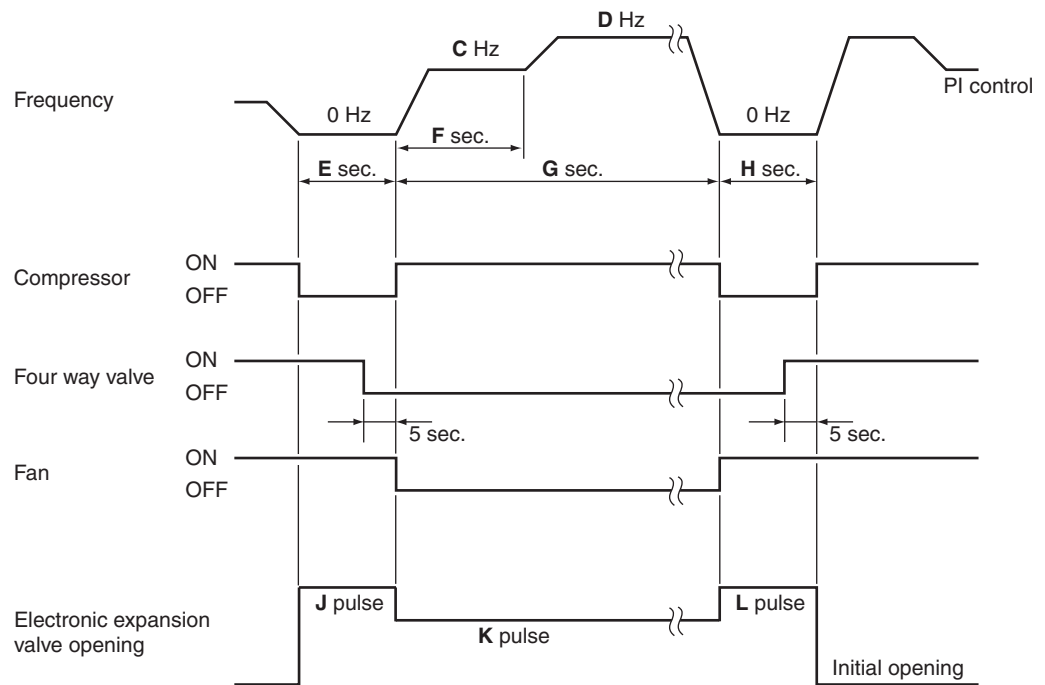

(R19555)

	20/25/35 class	50 class
A (minutes)	28	44
B (°C)	4 ~ 18	4 ~ 12
C (Hz)	76	55
D (Hz)	86	90
E (seconds)	50	60
F (seconds)	60	120
G (seconds)	480	340
H (seconds)	60	50
J (pulse)	450	450
K (pulse)	350	350
L (pulse)	450	450

3.11 Electronic Expansion Valve Control

Outline

The following items are included in the electronic expansion valve control.

Electronic expansion valve is fully closed

1. Electronic expansion valve is fully closed when turning on the power.
2. Pressure equalizing control

Open Control

1. Electronic expansion valve control when starting operation
2. Electronic expansion valve control when the frequency changes
3. Electronic expansion valve control for defrosting
4. Electronic expansion valve control when the discharge pipe temperature is abnormally high
5. Electronic expansion valve control when the discharge pipe thermistor is disconnected

Feedback Control

Target discharge pipe temperature control

Detail

The followings are the examples of electronic expansion valve control which function in each operation mode.

	Power on ; Compressor stop	Operation start	Frequency change under starting control	During target discharge pipe temperature control	Frequency change under target discharge pipe temperature control	Discharge pipe thermistor disconnection	Frequency change under discharge pipe thermistor disconnection control	During defrost control
Starting operation control	—	●	—	—	—	—	—	—
Control when the frequency changes	—	—	●	—	●	—	—	—
Target discharge pipe temperature control	—	—	—	●	—	—	—	—
Discharge pipe thermistor disconnection control	—	—	—	—	—	●	●	—
High discharge pipe temperature control	—	●	●	●	●	—	—	—
Defrost control (heating only)	—	—	—	—	—	—	—	●
Pressure equalizing control	●	—	—	—	—	—	—	—
Opening limit control	—	●	●	●	●	●	●	—

● : Available

— : Not available

3.11.1 Fully Closing with Power ON

The electronic expansion valve is initialized when turning on the power. The opening position is set and the pressure is equalized.

3.11.2 Pressure Equalizing Control

When the compressor is stopped, the pressure equalizing control is activated. The electronic expansion valve opens and the pressure is equalized.

3.11.3 Opening Limit Control

The maximum and minimum opening of the electronic expansion valve are limited.

	20/25/35 class	50 class
Maximum opening (pulse)	480	480
Minimum opening (pulse)	32	54

The electronic expansion valve is fully closed when cooling operation stops, and is opened at a fixed degree during defrosting.

3.11.4 Starting Operation Control

The electronic expansion valve opening is controlled when the operation starts, thus preventing superheating or liquid compression.

3.11.5 Control when the Frequency Changes

When the target discharge pipe temperature control is active, if the target frequency changes to a specified value in a certain time period, the target discharge pipe temperature control is canceled and the target opening of the electronic expansion valve is changed according to the frequency shift.

3.11.6 High Discharge Pipe Temperature Control

When the compressor is operating, if the discharge pipe temperature exceeds a certain value, the electronic expansion valve opens and the refrigerant runs to the low pressure side. This procedure lowers the discharge pipe temperature.

3.11.7 Discharge Pipe Thermistor Disconnection Control

Outline

The disconnection of the discharge pipe thermistor is detected by comparing the discharge pipe temperature with the condensation temperature. If the discharge pipe thermistor is disconnected, the electronic expansion valve opens according to the outdoor temperature and the operation frequency, operates for a specified time, and then stops.

After 3 minutes, the operation restarts and checks if the discharge pipe thermistor is disconnected. If the discharge pipe thermistor is disconnected, the system stops after operating for a specified time.

If the disconnection is detected repeatedly, the system is shut down. When the compressor runs for 60 minutes without any error, the error counter is reset.

Detail

When the starting control (cooling: **A** seconds, heating: **B** seconds) finishes, the detection timer for disconnection of the discharge pipe thermistor (**C** seconds) starts. When the timer is over, the following adjustment is made.

1. When the operation mode is cooling

When the following condition is fulfilled, the discharge pipe thermistor disconnection is ascertained.

Discharge pipe temperature + 6°C < outdoor heat exchanger temperature

2. When the operation mode is heating

When the following condition is fulfilled, the discharge pipe thermistor disconnection is ascertained.

Discharge pipe temperature + 6°C < indoor heat exchanger temperature

	20/25/35 class	50 class
A (seconds)	10	10
B (seconds)	120	30
C (seconds)	810	540

When the thermistor is disconnected

When the disconnection is ascertained, the compressor continues operation for 9 minutes and then stops.

If the compressor stops repeatedly, the system is shut down.

3.11.8 Target Discharge Pipe Temperature Control

The target discharge pipe temperature is obtained from the indoor and outdoor heat exchanger temperature, and the electronic expansion valve opening is adjusted so that the actual discharge pipe temperature becomes close to the target discharge pipe temperature. (Indirect SH (superheating) control using the discharge pipe temperature)

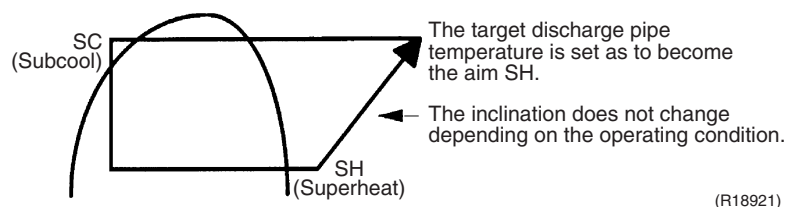

(R18921)

The electronic expansion valve opening and the target discharge pipe temperature are checked every 20 seconds. The opening degree of the electronic expansion valve is adjusted by the followings.

- ◆ Target discharge pipe temperature
- ◆ Actual discharge pipe temperature
- ◆ Previous discharge pipe temperature

3.12 Malfunctions

3.12.1 Sensor Malfunction Detection

Sensor malfunction can be detected in the following thermistors:

1. Outdoor heat exchanger thermistor
2. Discharge pipe thermistor
3. Radiation fin thermistor
4. Outdoor temperature thermistor

3.12.2 Detection of Overcurrent and Overload

Outline

An excessive output current is detected and the OL temperature is observed to protect the compressor.

Detail

- If the OL (compressor head) temperature exceeds 120°C, the system shuts down the compressor.
- If the inverter current exceeds 9.25 ~ 20 A (depending on the model), the system shuts down the compressor.

3.12.3 Refrigerant Shortage Detection

I: Detecting by power consumption

If the power consumption is below the specified value and the frequency is higher than the specified frequency, it is regarded as refrigerant shortage.

The power consumption is low comparing with that in the normal operation when refrigerant is insufficient, and refrigerant shortage is detected by checking power consumption.

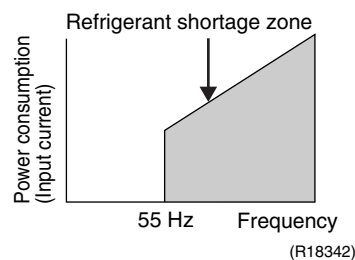

II: Detecting by discharge pipe temperature

If the discharge pipe temperature is higher than the target discharge pipe temperature, and the electronic expansion valve is fully open for more than the specified time, it is regarded as refrigerant shortage.

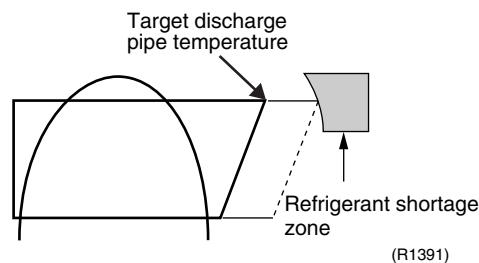

III: Detecting by the difference of temperature (20/25/35 class only)

If the difference between suction and discharge temperature is smaller than the specified value, it is regarded as refrigerant shortage.



Refer to page 65 for detail.

Part 5

Remote Controller

1. Remote controller.....50

1. Remote controller

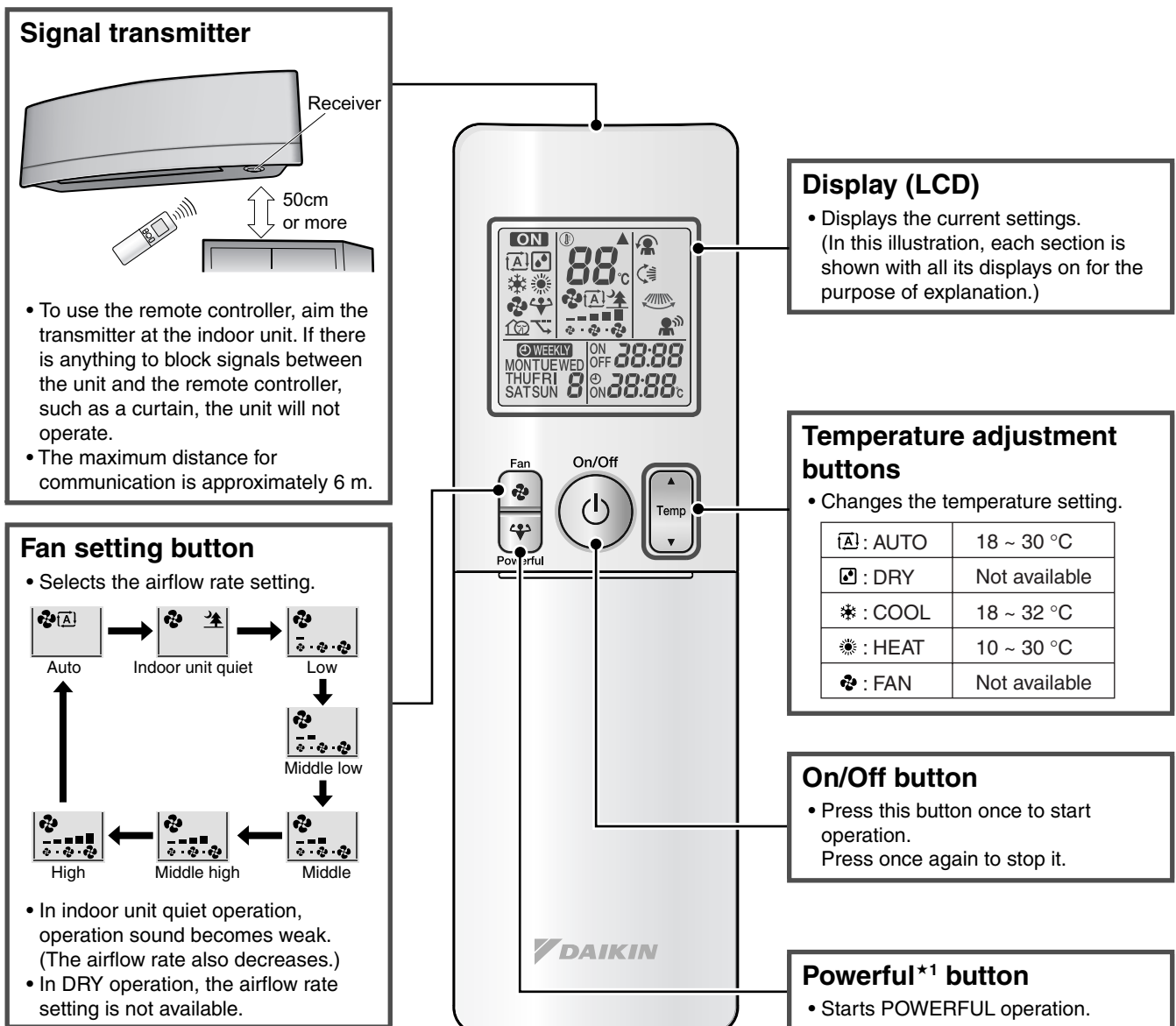

(R19928)

< ARC466A9 >

Reference

Refer to the following pages for detail.

★1	POWERFUL operation	P.27
----	--------------------	------



Note:

Refer to the operation manual of applicable model for detail. You can download operation manual from DISTRIBUTOR'S PAGE:

DISTRIBUTOR'S PAGE → Product Information → Operation/Installation Manual

(URL: http://global.daikin.com/Daikin/global/Distributors_admin/user_mng/login.php)

Open the Front Cover

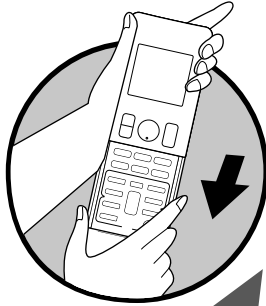

Mode button

• Selects the operation mode.

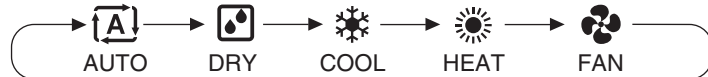

Lamp brightness setting button

• Each time you press the **Brightness** button, the brightness of the indoor unit display changes to high, low, or off.

Comfort/Sensor button (COMFORT AIRFLOW Operation^{*2}/ INTELLIGENT EYE Operation^{*3})

• Every time you press the **Comfort/Sensor** button, the setting changes in the following order.

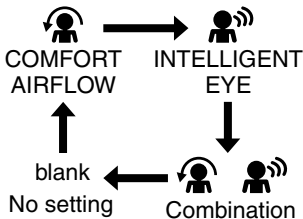

Off Timer button

• Press this button and adjust the day and time with the **Select** button. Press this button again to complete TIMER setting.

Timer cancel button

• Cancels the timer setting.
• It cannot be used for the WEEKLY TIMER operation.

Select button

• Changes the ON/OFF TIMER and WEEKLY TIMER settings.

Clock^{*7} button

On Timer button

• Press this button and adjust the day and time with the **Select** button. Press this button again to complete TIMER setting.

Econo^{*4} / Quiet button

• Every time you press the **Econo/Quiet** button, the setting changes in the following order.

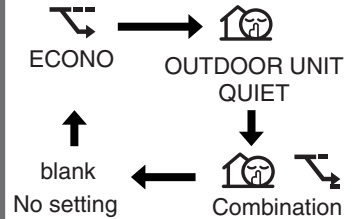

• OUTDOOR UNIT QUIET operation is not available in FAN and DRY operation.
• OUTDOOR UNIT QUIET operation and POWERFUL operation cannot be used at the same time. Priority is given to the function you pressed last.

Swing^{*5} button

• Adjusts the airflow direction.
• When you press the **Swing** button, the flap moves up and down, or (and) the louver moves right and left. The flap (louver) stops when you press the **Swing** button again.

Weekly

[Button] : Weekly button



[Button] : Program button

Copy

[Button] : Copy button

Back

[Button] : Back button

Next

[Button] : Next button

• WEEKLY TIMER^{*6} operation.

(R19929)

Reference

Refer to the following pages for detail.

★2	COMFORT AIRFLOW operation	P.19, 20	★5	Auto-swing setting	P.19
★3	2-area INTELLIGENT EYE operation	P.25	★6	WEEKLY TIMER operation	P.29
★4	ECONO operation	P.24	★7	Clock setting	P.28



Note:

Refer to the operation manual of applicable model for detail. You can download operation manual from DISTRIBUTOR'S PAGE:

DISTRIBUTOR'S PAGE → Product Information → Operation/Installation Manual

(URL: http://global.daikin.com/Daikin/global/Distributors_admin/user_mng/login.php)

Part 6

Service Diagnosis

1. General Problem Symptoms and Check Items	53
2. Troubleshooting with LED	54
2.1 Indoor Unit.....	54
2.2 Outdoor Unit.....	54
3. Service Diagnosis	55
4. Troubleshooting	58
4.1 Error Codes and Description	58
4.2 Indoor Unit PCB Abnormality	59
4.3 Freeze-up Protection Control / Heating Peak-cut Control	60
4.4 Fan Motor (DC Motor) or Related Abnormality.....	61
4.5 Thermistor or Related Abnormality (Indoor Unit).....	63
4.6 Front Panel Open / Close Fault.....	64
4.7 Refrigerant Shortage	65
4.8 Low-voltage Detection or Over-voltage Detection.....	67
4.9 Signal Transmission Error (Between Indoor Unit and Outdoor Unit).....	69
4.10 Unspecified Voltage (Between Indoor Unit and Outdoor Unit)	71
4.11 Outdoor Unit PCB Abnormality.....	72
4.12 OL Activation (Compressor Overload)	73
4.13 Compressor Lock	75
4.14 DC Fan Lock	76
4.15 Input Overcurrent Detection	77
4.16 Four Way Valve Abnormality	78
4.17 Discharge Pipe Temperature Control.....	80
4.18 High Pressure Control in Cooling	81
4.19 Compressor System Sensor Abnormality	82
4.20 Position Sensor Abnormality	83
4.21 DC Voltage / Current Sensor Abnormality (20/25/35 Class Only).....	85
4.22 Thermistor or Related Abnormality (Outdoor Unit).....	86
4.23 Electrical Box Temperature Rise	88
4.24 Radiation Fin Temperature Rise	89
4.25 Output Overcurrent Detection	91
5. Check	93
5.1 Thermistor Resistance Check	93
5.2 Fan Motor Connector Output Check	94
5.3 Power Supply Waveforms Check.....	94
5.4 Electronic Expansion Valve Check.....	94
5.5 Four Way Valve Performance Check	95
5.6 Inverter Unit Refrigerant System Check.....	95
5.7 Inverter Analyzer Check.....	96
5.8 Rotation Pulse Check on the Outdoor Unit PCB	97
5.9 Installation Condition Check.....	98
5.10 Discharge Pressure Check.....	99
5.11 Outdoor Fan System Check	99
5.12 Main Circuit Short Check.....	100
5.13 Power Module Check	101

1. General Problem Symptoms and Check Items

Symptom	Check Item	Measures	Reference Page
The unit does not operate.	Check the power supply.	Check if the rated voltage is supplied.	—
	Check the type of the indoor unit.	Check if the indoor unit type is compatible with the outdoor unit.	—
	Check the outdoor temperature.	Heating operation cannot be used when the outdoor temperature is 24°C or higher, and cooling operation cannot be used when the outdoor temperature is below -10°C.	—
	Diagnose with remote controller indication.	—	58
	Check the remote controller addresses.	Check if address settings for the remote controller and indoor unit are correct.	107
Operation sometimes stops.	Check the power supply.	A power failure of 2 to 10 cycles stops air conditioner operation. (Operation lamp OFF)	—
	Check the outdoor temperature.	Heating operation cannot be used when the outdoor temperature is 24°C or higher, and cooling operation cannot be used when the outdoor temperature is below -10°C.	—
	Diagnose with remote controller indication.	—	58
The unit operates but does not cool, or does not heat.	Check for wiring and piping errors in the connection between the indoor unit and outdoor unit.	—	—
	Check for thermistor detection errors.	Check if the thermistor is mounted securely.	—
	Check for faulty operation of the electronic expansion valve.	Set the unit to cooling operation, and check the temperature of the liquid pipe to see if the electronic expansion valve works.	—
	Diagnose with remote controller indication.	—	58
	Diagnose by service port pressure and operating current.	Check for refrigerant shortage.	65
Large operating noise and vibrations	Check the output voltage of the power module.	—	101
	Check the power module.	—	—
	Check the installation condition.	Check if the required spaces for installation (specified in the installation manual) are provided.	—

2. Troubleshooting with LED

2.1 Indoor Unit

Operation Lamp

The multi-monitor lamp blinks when any of the following errors is detected.

1. When a protection device of the indoor or outdoor unit is activated, or when the thermistor malfunctions.
 2. When a signal transmission error occurs between the indoor and outdoor units.
- In either case, conduct the diagnostic procedure described in the following pages.

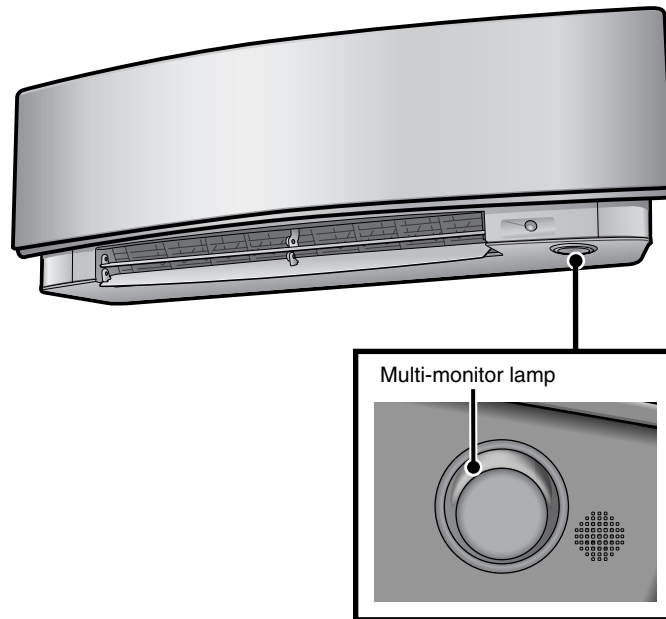

(R19930)

Service Monitor

The indoor unit has one green LED (LED A) on the control PCB. When the microcomputer works in order, the LED A blinks.

2.2 Outdoor Unit

The outdoor unit has one green LED (LED A) on the PCB. When the microcomputer works in order, the LED A blinks.

3. Service Diagnosis

Method 1

1. When the timer cancel button is held down for 5 seconds, **00** is displayed on the temperature display screen.

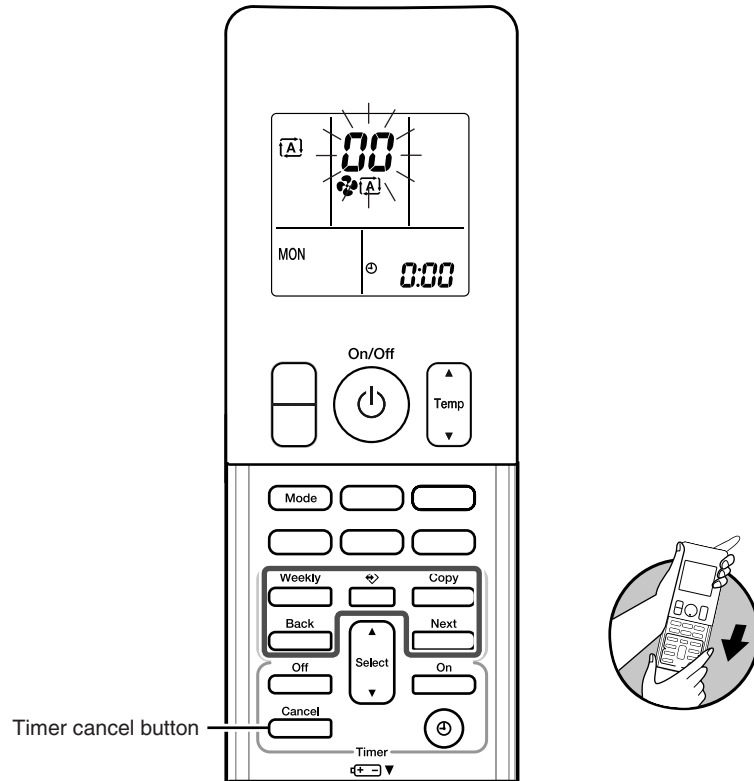

< ARC466 Series >

(R14553)

2. Press the timer cancel button repeatedly until a long beep sounds.
 - The code indication changes in the sequence shown below.

No.	Code	No.	Code	No.	Code
1	00	13	C7	25	UR
2	U4	14	R3	26	UN
3	L5	15	H8	27	P4
4	E6	16	H9	28	L3
5	H6	17	C9	29	L4
6	H0	18	C4	30	H7
7	R6	19	C5	31	U2
8	E7	20	J3	32	ER
9	U0	21	J6	33	R4
10	F3	22	E5	34	FR
11	R5	23	R1	35	H1
12	F6	24	E1	36	P9



Note:

1. A short beep or two consecutive beeps indicate non-corresponding codes.
2. To return to the normal mode, hold the timer cancel button down for 5 seconds. When the remote controller is left untouched for 60 seconds, it also returns to the normal mode.
3. Not all the error codes are displayed. When you cannot find the error code, try method 2. (→ Refer to page 56.)

Method 2

1. Press the center of the **Temp** button and the **Mode** button at the same time.

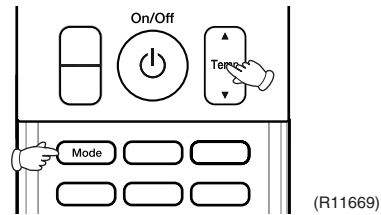

5ℓ is displayed on the LCD.

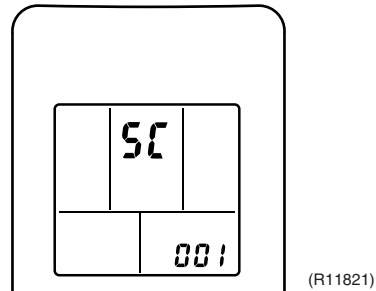

2. Select 5ℓ (service check) with the **Temp ▲** or **Temp ▼** button.
3. Press the **Mode** button to enter the service check mode.

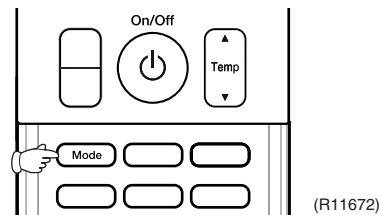

The left-side number blinks

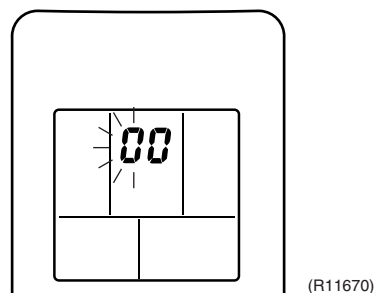

4. Press the **Temp ▲** or **Temp ▼** button and change the number until you hear the two consecutive beeps or the long beep.

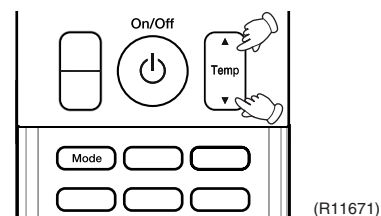

5. Diagnose by the sound.
 - ★ beep: The left-side number does not correspond with the error code.
 - ★ two consecutive beeps: The left-side number corresponds with the error code but the right-side number does not.
 - ★ long beep: Both the left-side and right-side numbers correspond with the error code.
(The numbers indicated when you hear the long beep are the error code.
→ Refer to page 58.)

6. Press the **Mode** button.

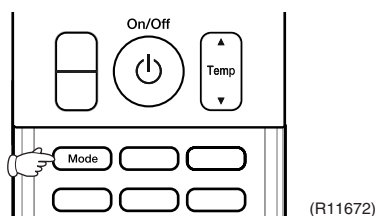

The right-side number blinks.

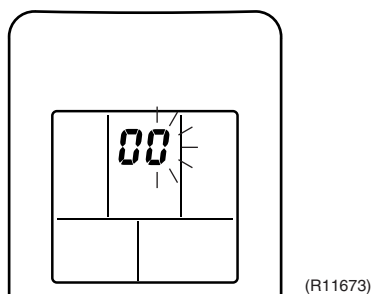

7. Press the **Temp ▲** or **Temp ▼** button and change the number until you hear the long beep.

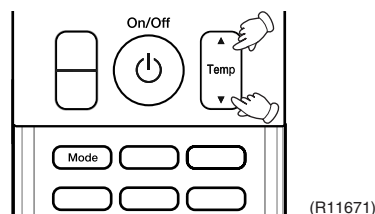

8. Diagnose by the sound.
 - ★ beep: The left-side number does not correspond with the error code.
 - ★ two consecutive beeps: The left-side number corresponds with the error code but the right-side number does not.
 - ★ long beep: Both the left-side and right-side numbers correspond with the error code.

9. Determine the error code.
The numbers indicated when you hear the long beep are the error code.
Error codes and description → Refer to page 58.

10. Press the **Mode** button for 5 seconds to exit from the service check mode.
(When the remote controller is left untouched for 60 seconds, it returns to the normal mode also.)

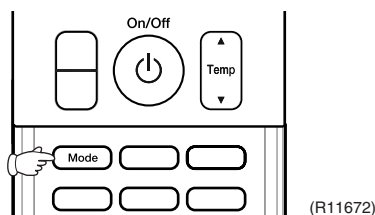

4. Troubleshooting

4.1 Error Codes and Description

	Error Codes	Description	Reference Page
System	00	Normal	—
	U0★	Refrigerant shortage	65
	U2	Low-voltage detection or over-voltage detection	67
	U4	Signal transmission error (between indoor unit and outdoor unit)	69
	U8	Unspecified voltage (between indoor unit and outdoor unit)	71
Indoor Unit	P1	Indoor unit PCB abnormality	59
	P5	Freeze-up protection control / heating peak-cut control	60
	P6	Fan motor (DC motor) or related abnormality	61
	C4	Indoor heat exchanger thermistor or related abnormality	63
	C7	Front panel open / close fault	64
	C9	Room temperature thermistor or related abnormality	63
Outdoor Unit	E1	Outdoor unit PCB abnormality	72
	E5★	OL activation (compressor overload)	73
	E6★	Compressor lock	75
	E7★	DC fan lock	76
	E8	Input overcurrent detection	77
	E8	Four way valve abnormality	78
	F3	Discharge pipe temperature control	80
	F6	High pressure control in cooling	81
	H0	Compressor system sensor abnormality	82
	H6	Position sensor abnormality	83
	H8	DC voltage / current sensor abnormality (20/25/35 class only)	85
	H9	Outdoor temperature thermistor or related abnormality	86
	J3★	Discharge pipe thermistor or related abnormality	86
	J5	Outdoor heat exchanger thermistor or related abnormality	86
	L3	Electrical box temperature rise	88
	L4	Radiation fin temperature rise	89
	L5★	Output overcurrent detection	91
	P4	Radiation fin thermistor or related abnormality	86

★: Displayed only when system-down occurs.

4.2 Indoor Unit PCB Abnormality

Error Code	A1
Method of Error Detection	The system checks if the circuit works properly within the microcomputer of the indoor unit.
Error Decision Conditions	The system cannot set the internal settings.
Supposed Causes	<ul style="list-style-type: none"> ■ Wrong models interconnected ■ Defective indoor unit PCB ■ Disconnection of connector ■ Reduction of power supply voltage

Troubleshooting

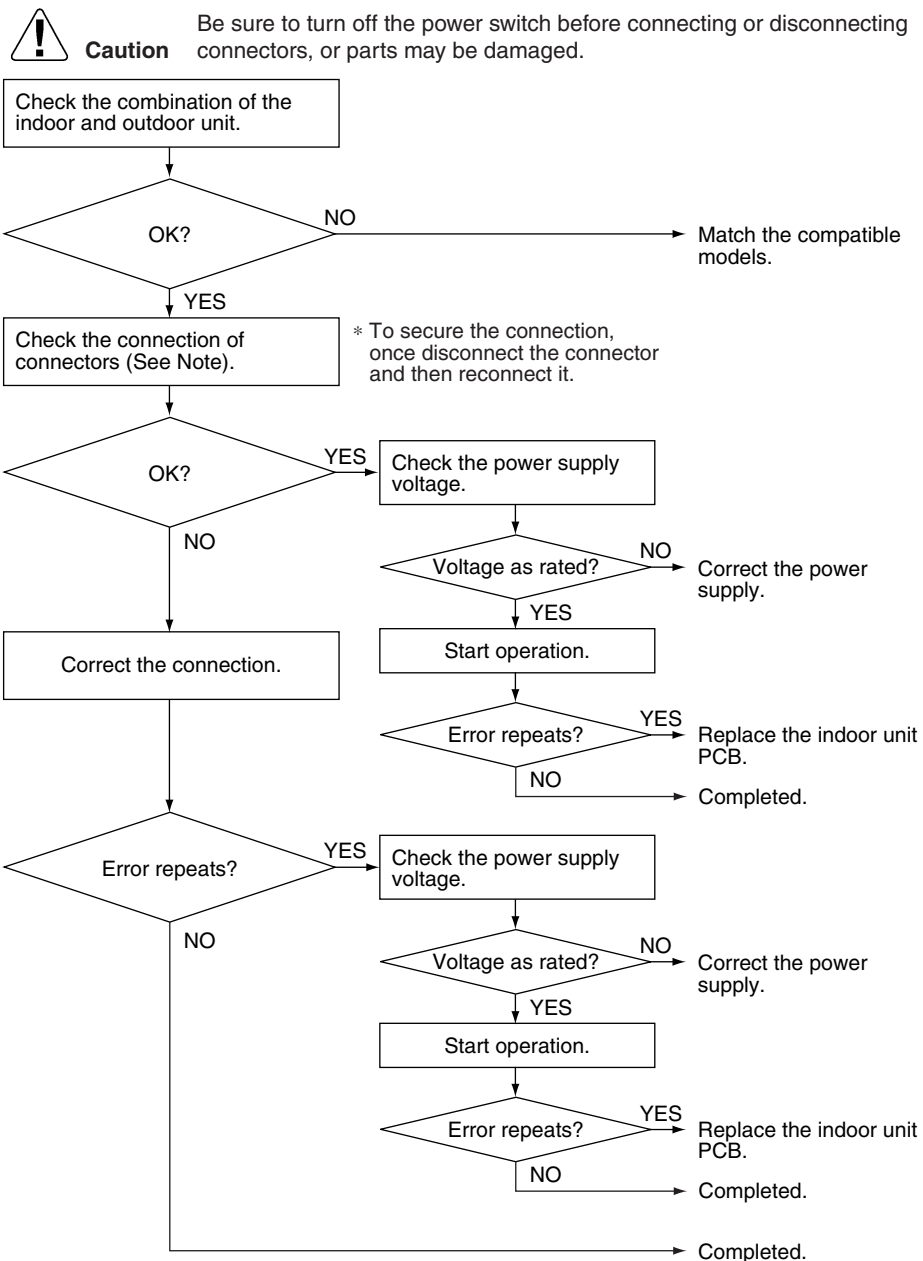

i Note: Check the following connector.

Model Type	Connector
Wall mounted type	Terminal board ~ Control PCB (H1, H2, H3)

(R15310)

4.3 Freeze-up Protection Control / Heating Peak-cut Control

Error Code	A5
Method of Error Detection	<ul style="list-style-type: none"> ■ Freeze-up protection control During cooling operation, the freeze-up protection control (operation halt) is activated according to the temperature detected by the indoor heat exchanger thermistor. ■ Heating peak-cut control During heating operation, the temperature detected by the indoor heat exchanger thermistor is used for the heating peak-cut control (operation halt, outdoor fan stop, etc.)
Error Decision Conditions	<ul style="list-style-type: none"> ■ Freeze-up protection control During cooling operation, the indoor heat exchanger temperature is below 0°C. ■ Heating peak-cut control During heating operation, the indoor heat exchanger temperature is above 65°C.
Supposed Causes	<ul style="list-style-type: none"> ■ Short-circuited air ■ Clogged air filter of the indoor unit ■ Dust accumulation on the indoor heat exchanger ■ Defective indoor heat exchanger thermistor ■ Defective indoor unit PCB

Troubleshooting

Check No.01
 Refer to P.93

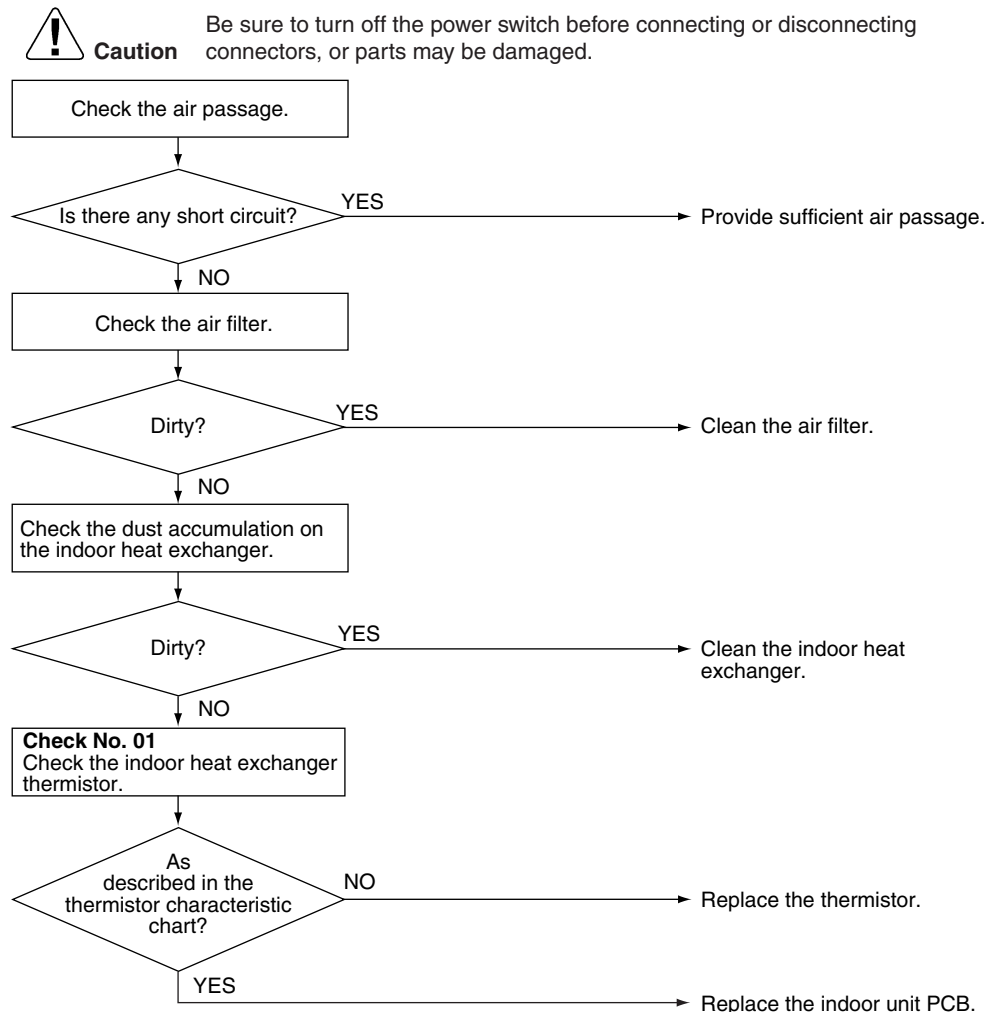

(R15715)

4.4 Fan Motor (DC Motor) or Related Abnormality

Error Code	FE
Method of Error Detection	The rotation speed detected by the Hall IC during fan motor operation is used to determine abnormal fan motor operation.
Error Decision Conditions	The detected rotation speed does not reach the demanded rotation speed of the target tap, and is less than 50% of the maximum fan motor rotation speed.
Supposed Causes	<ul style="list-style-type: none">■ Remarkable decrease in power supply voltage■ Layer short inside the fan motor winding■ Breaking of wire inside the fan motor■ Breaking of the fan motor lead wires■ Defective capacitor of the fan motor■ Defective indoor unit PCB

Troubleshooting



Check No.02
Refer to P.94



Caution

Be sure to turn off the power switch before connecting or disconnecting connectors, or parts may be damaged.

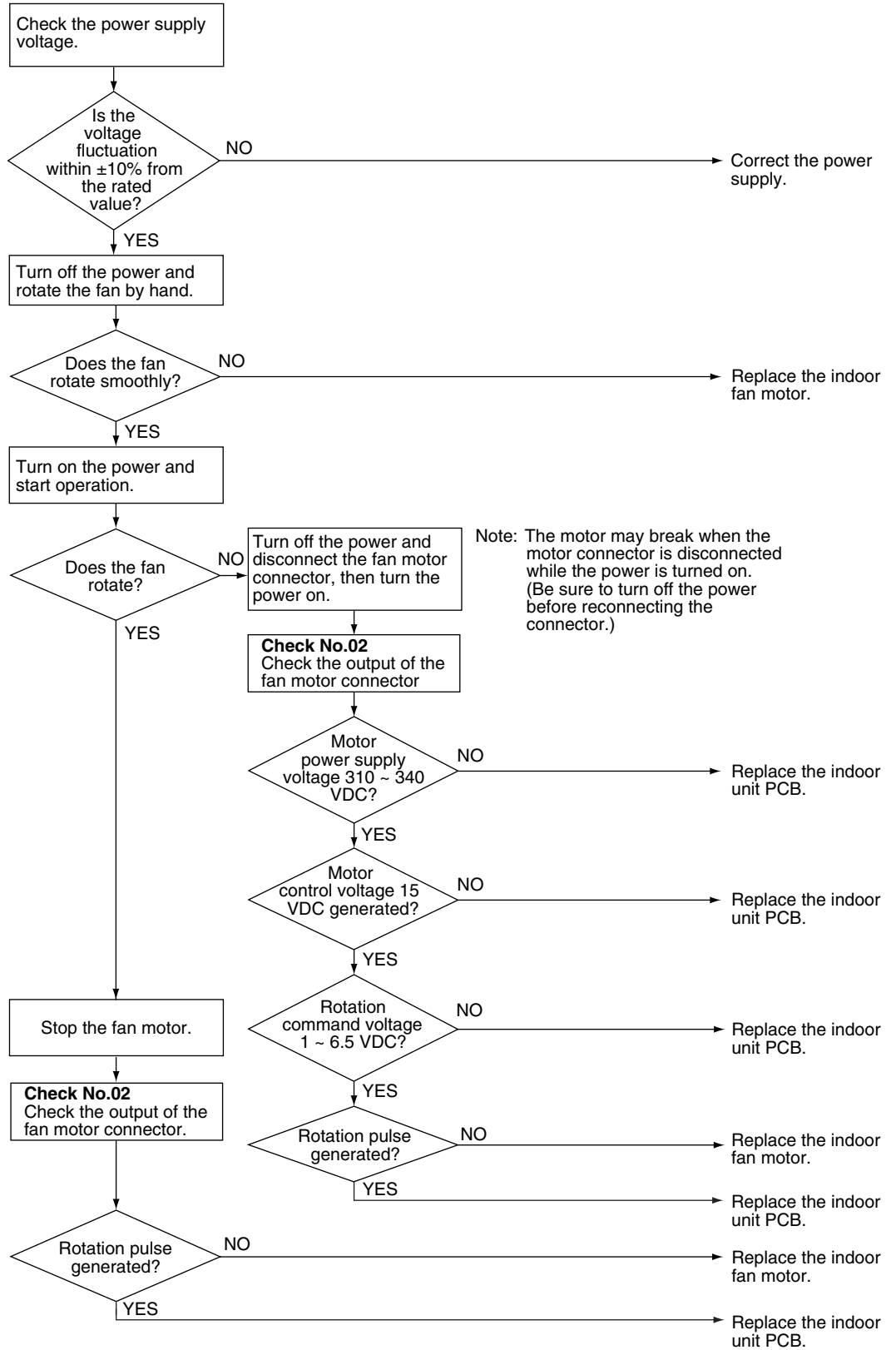

(R19750)

4.5 Thermistor or Related Abnormality (Indoor Unit)

Error Code E4, E9

Method of Error Detection The temperatures detected by the thermistors determine thermistor errors.

Error Decision Conditions The thermistor input is 4.96 V and more or 0.04 V and less during compressor operation.

- Supposed Causes**
- Disconnection of connector
 - Thermistor corresponding to the error code is defective.
 - Defective indoor unit PCB

Troubleshooting

Check No.01
Refer to P.93

 **Caution** Be sure to turn off the power switch before connecting or disconnecting connectors, or parts may be damaged.

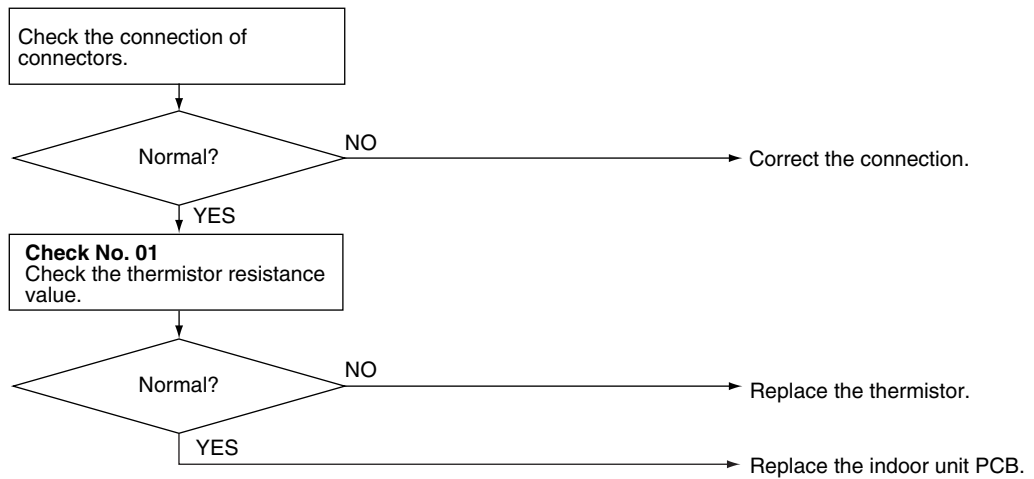

(R15717)

E4 : Indoor heat exchanger thermistor
 E9 : Room temperature thermistor

4.6 Front Panel Open / Close Fault

Error Code

E7

Method of Error Detection

Error Decision Conditions

- If the error repeats, the system is shut down.

Supposed Causes

- Defective reduction motor
- Malfunction or deterioration of the front panel mechanism
- Defective limit switch

Troubleshooting

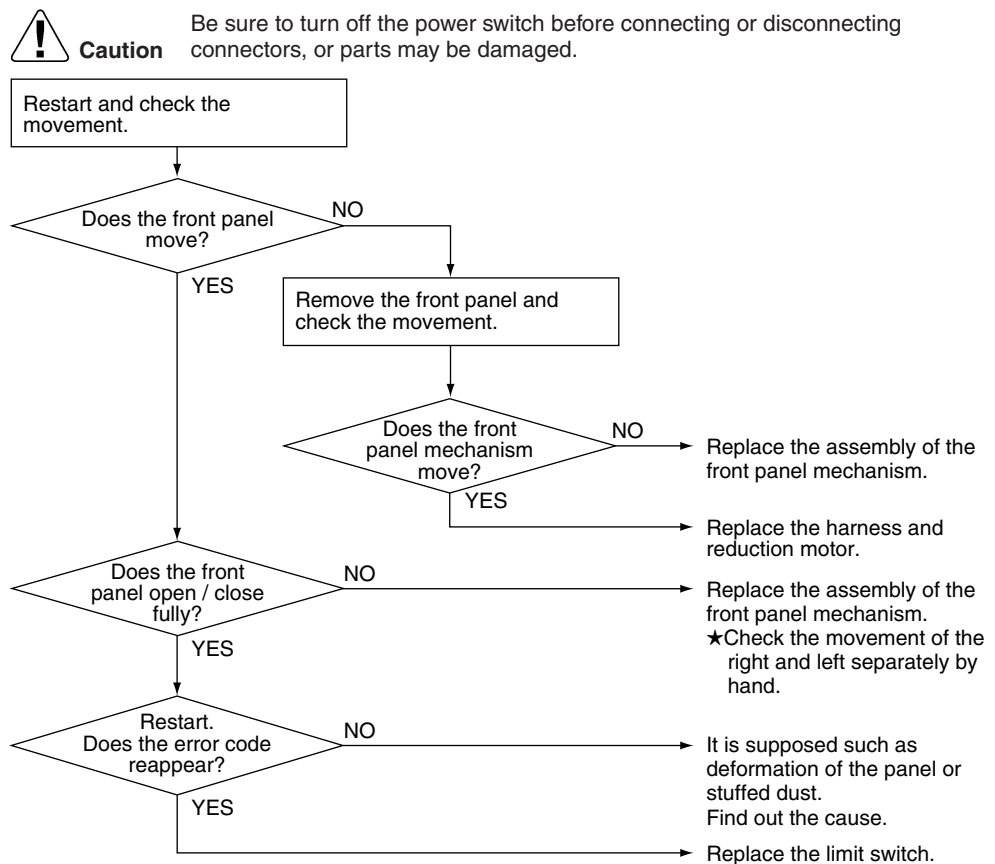

(R17249)



Note:

You cannot operate the unit by the remote controller when the front panel mechanism breaks down.

<To the dealers: temporary measure before repair>

1. Turn off the power.
2. Remove the front panel.
3. Turn on the power.
(Wait until the initialization finishes.)
4. Operate the unit by the indoor unit **ON/OFF** button.

4.7 Refrigerant Shortage

Error Code	U0																																					
Method of Error Detection	<p>Refrigerant shortage detection I: Refrigerant shortage is detected by checking the input current value and the compressor running frequency. If the refrigerant is short, the input current is lower than the normal value.</p> <p>Refrigerant shortage detection II: Refrigerant shortage is detected by checking the discharge pipe temperature and the opening of the electronic expansion valve. If the refrigerant is short, the discharge pipe temperature tends to rise.</p> <p>Refrigerant shortage detection III: (20/25/35 class only) Refrigerant shortage is detected by checking the difference between suction and discharge temperature.</p>																																					
Error Decision Conditions	<p>Refrigerant shortage detection I: The following conditions continue for 7 minutes.</p> <ul style="list-style-type: none"> ◆ Input current × input voltage ≤ A × output frequency + B ◆ Output frequency > C <table border="1" style="width: 100%; border-collapse: collapse; text-align: center;"> <thead> <tr> <th></th> <th>A (constant)</th> <th>B (W)</th> <th>C (Hz)</th> </tr> </thead> <tbody> <tr> <td>20/25/35 class</td> <td>640/256</td> <td>0</td> <td>55</td> </tr> <tr> <td>50 class</td> <td>2000/256</td> <td>-181</td> <td>55</td> </tr> </tbody> </table> <p>Refrigerant shortage detection II: The following conditions continue for 80 seconds.</p> <ul style="list-style-type: none"> ◆ Opening of the electronic expansion valve ≥ D ◆ Discharge pipe temperature > E × target discharge pipe temperature + F <table border="1" style="width: 100%; border-collapse: collapse; text-align: center;"> <thead> <tr> <th></th> <th>D (pulse)</th> <th>E (constant)</th> <th>F (°C)</th> </tr> </thead> <tbody> <tr> <td>20/25/35 class</td> <td>480</td> <td>128/128</td> <td>30</td> </tr> <tr> <td>50 class</td> <td>480</td> <td>128/128</td> <td>cooling: 60, heating: 45</td> </tr> </tbody> </table> <p>Refrigerant shortage detection III: (20/25/35 class only) When the difference of the temperature is smaller than G°C, it is regarded as refrigerant shortage.</p> <table border="1" style="width: 100%; border-collapse: collapse; text-align: center;"> <thead> <tr> <th>Operation mode</th> <th>Description</th> <th>G (°C)</th> </tr> </thead> <tbody> <tr> <td rowspan="2">Cooling</td> <td>room thermistor temperature – indoor heat exchanger temperature</td> <td>4.0</td> </tr> <tr> <td>outdoor heat exchanger temperature – outdoor temperature</td> <td>4.0</td> </tr> <tr> <td rowspan="2">Heating</td> <td>indoor heat exchanger temperature – room thermistor temperature</td> <td>3.0</td> </tr> <tr> <td>outdoor temperature – outdoor heat exchanger temperature</td> <td>3.0</td> </tr> </tbody> </table> <ul style="list-style-type: none"> ■ If the error repeats, the system is shut down. ■ Reset condition: Continuous run for about 60 minutes without any other error 		A (constant)	B (W)	C (Hz)	20/25/35 class	640/256	0	55	50 class	2000/256	-181	55		D (pulse)	E (constant)	F (°C)	20/25/35 class	480	128/128	30	50 class	480	128/128	cooling: 60, heating: 45	Operation mode	Description	G (°C)	Cooling	room thermistor temperature – indoor heat exchanger temperature	4.0	outdoor heat exchanger temperature – outdoor temperature	4.0	Heating	indoor heat exchanger temperature – room thermistor temperature	3.0	outdoor temperature – outdoor heat exchanger temperature	3.0
	A (constant)	B (W)	C (Hz)																																			
20/25/35 class	640/256	0	55																																			
50 class	2000/256	-181	55																																			
	D (pulse)	E (constant)	F (°C)																																			
20/25/35 class	480	128/128	30																																			
50 class	480	128/128	cooling: 60, heating: 45																																			
Operation mode	Description	G (°C)																																				
Cooling	room thermistor temperature – indoor heat exchanger temperature	4.0																																				
	outdoor heat exchanger temperature – outdoor temperature	4.0																																				
Heating	indoor heat exchanger temperature – room thermistor temperature	3.0																																				
	outdoor temperature – outdoor heat exchanger temperature	3.0																																				
Supposed Causes	<ul style="list-style-type: none"> ■ Disconnection of the discharge pipe thermistor, indoor or outdoor heat exchanger thermistor, room or outdoor temperature thermistor ■ Closed stop valve ■ Refrigerant shortage (refrigerant leakage) ■ Poor compression performance of compressor ■ Defective electronic expansion valve 																																					

Troubleshooting

 **Check No.01**
Refer to P.93

 **Check No.12**
Refer to P.94

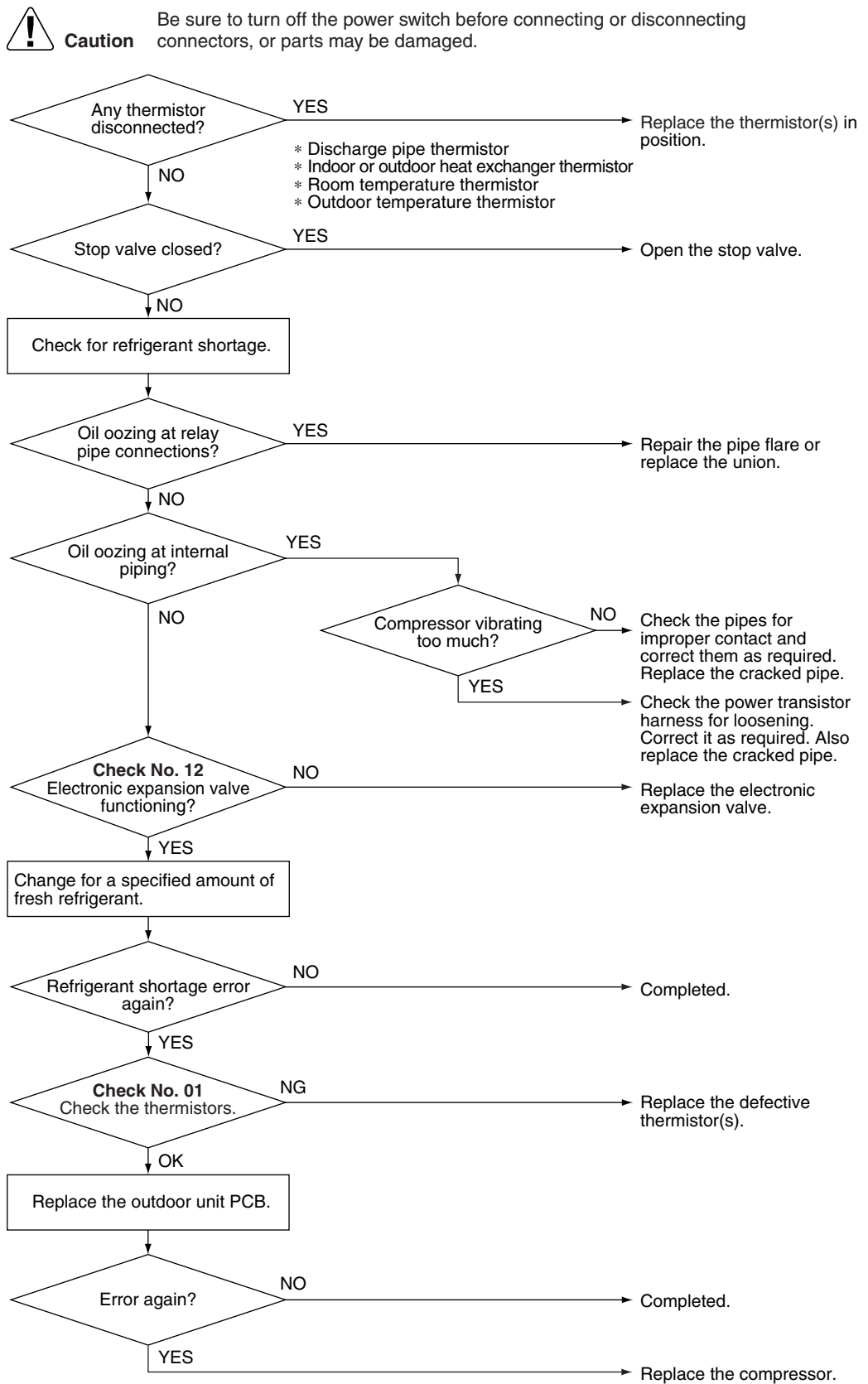

(R19373)

4.8 Low-voltage Detection or Over-voltage Detection

Error Code	U2
Method of Error Detection	<p>★ Indoor Unit</p> <p>The zero-cross detection of the power supply is evaluated by the indoor unit PCB.</p> <p>★ Outdoor Unit</p> <p>Low-voltage detection: An abnormal voltage drop is detected by the DC voltage detection circuit.</p> <p>Over-voltage detection: An abnormal voltage rise is detected by the over-voltage detection circuit.</p>
Error Decision Conditions	<p>★ Indoor Unit</p> <p>There is no zero-cross detection in approximately 10 seconds.</p> <p>★ Outdoor Unit</p> <p>Low-voltage detection:</p> <ul style="list-style-type: none"> ■ The voltage detected by the DC voltage detection circuit is below 150 ~ 180 V (depending on the model). ■ The compressor stops if the error occurs, and restarts automatically after 3-minute standby. <p>Over-voltage detection:</p> <ul style="list-style-type: none"> ■ An over-voltage signal is fed from the over-voltage detection circuit to the microcomputer. ■ The compressor stops if the error occurs, and restarts automatically after 3-minute standby.
Supposed Causes	<ul style="list-style-type: none"> ■ Power supply voltage is not as specified. ■ Defective DC voltage detection circuit ■ Defective over-voltage detection circuit ■ Defective PAM control part ■ Disconnection of compressor harness ■ Short circuit inside the fan motor winding ■ Noise ■ Momentary drop of voltage ■ Momentary power failure ■ Defective outdoor unit PCB ■ Defective indoor unit PCB

Troubleshooting

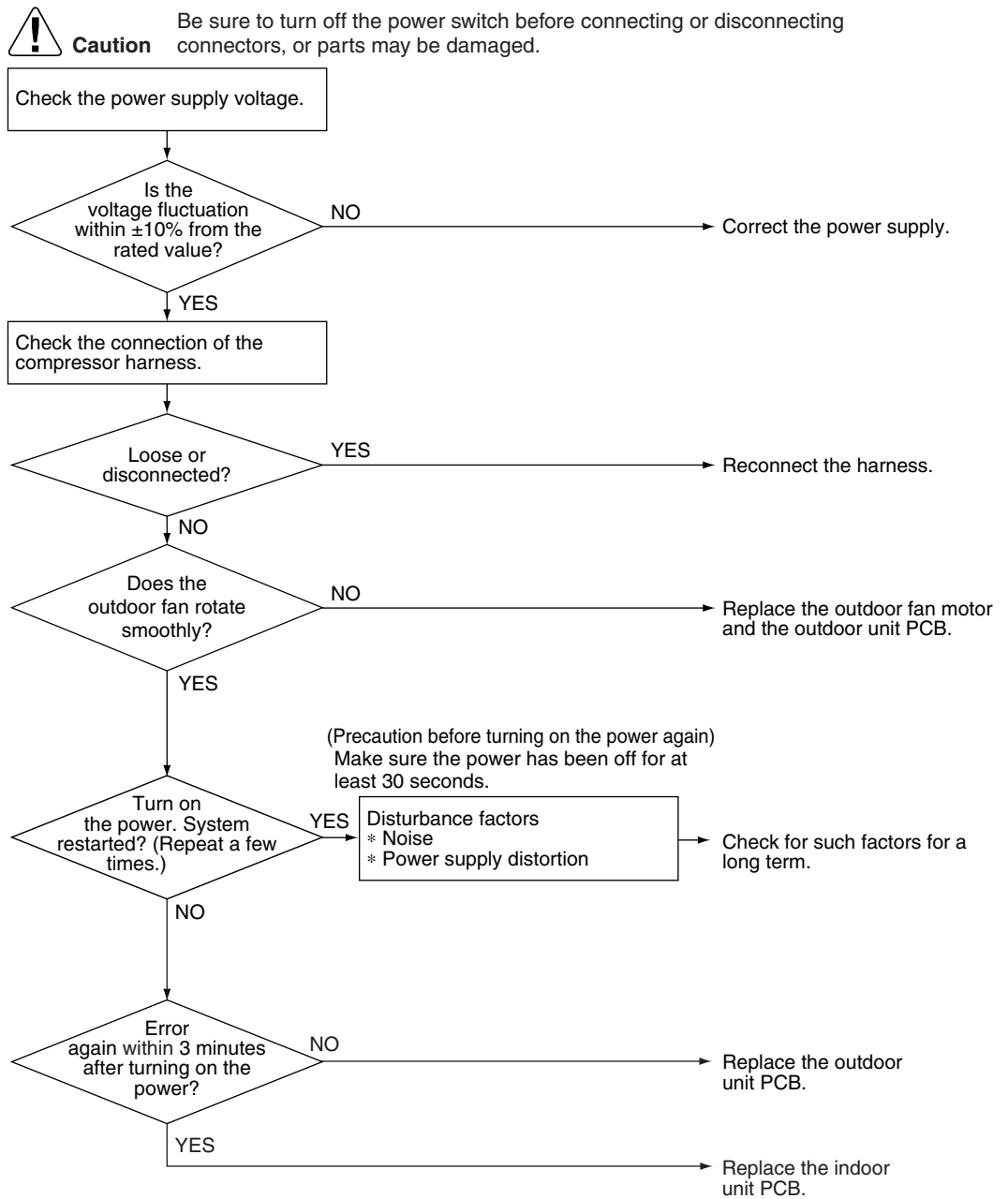

(R19955)

4.9 Signal Transmission Error (Between Indoor Unit and Outdoor Unit)

Error Code	U4
Method of Error Detection	The data received from the outdoor unit in signal transmission is checked whether it is normal.
Error Decision Conditions	The data sent from the outdoor unit cannot be received normally, or the content of the data is abnormal.
Supposed Causes	<ul style="list-style-type: none">■ Reduction of power supply voltage■ Wiring error■ Breaking of the connecting wires between the indoor and outdoor units (wire No. 3)■ Defective outdoor unit PCB■ Short circuit inside the fan motor winding■ Defective indoor unit PCB■ Disturbed power supply waveform

Troubleshooting



Check No.11
Refer to P.94

**Caution**

Be sure to turn off the power switch before connecting or disconnecting connectors, or parts may be damaged.

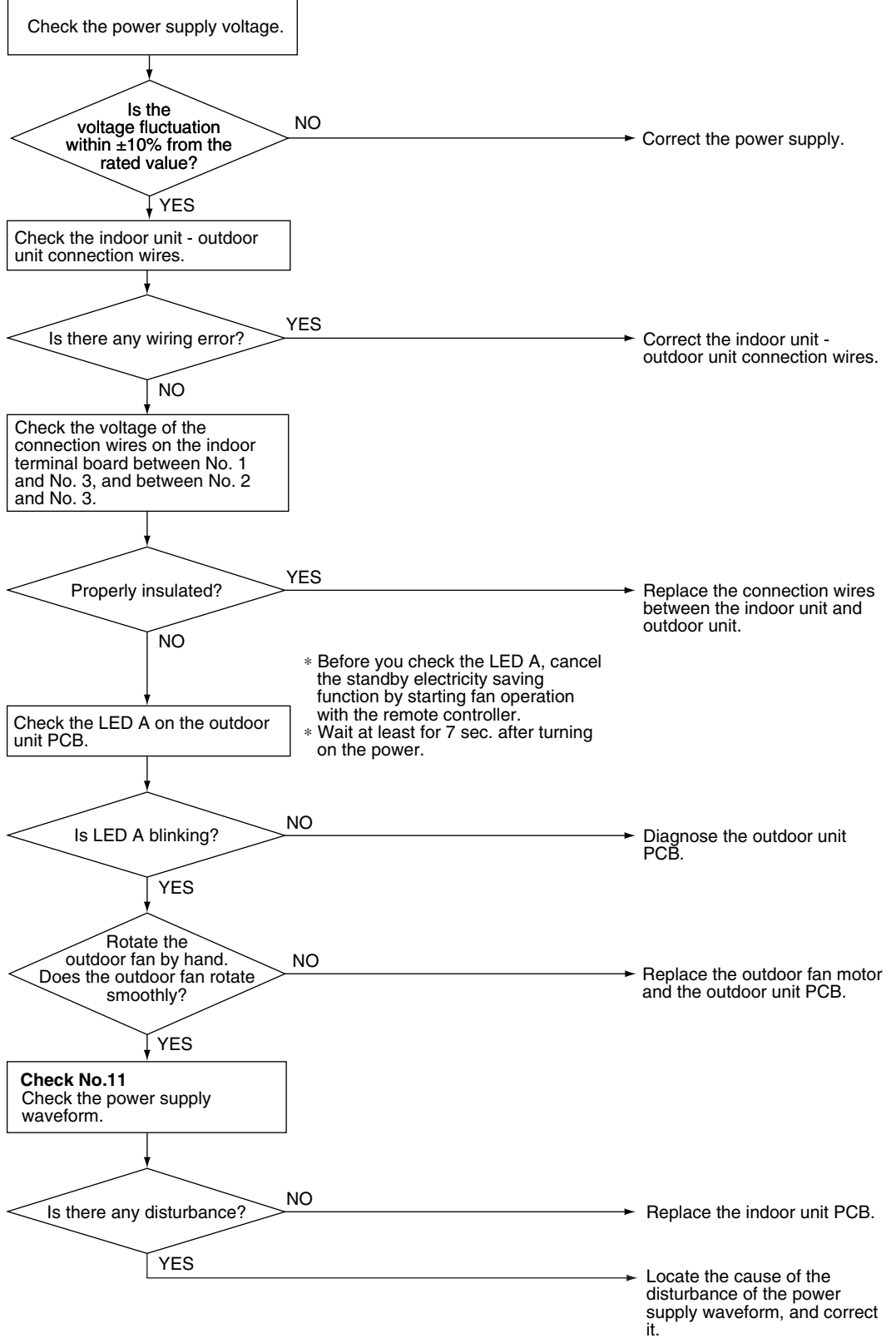

(R19956)

4.10 Unspecified Voltage (Between Indoor Unit and Outdoor Unit)

Error Code



Method of Error Detection

The supply power is detected for its requirements (pair type is different from multi type) by the indoor / outdoor transmission signal.

Error Decision Conditions

The pair type and multi type are interconnected.

Supposed Causes

- Wrong models interconnected
- Wrong wiring of connecting wires
- Wrong indoor unit PCB or outdoor unit PCB mounted
- Defective indoor unit PCB
- Defective outdoor unit PCB

Troubleshooting

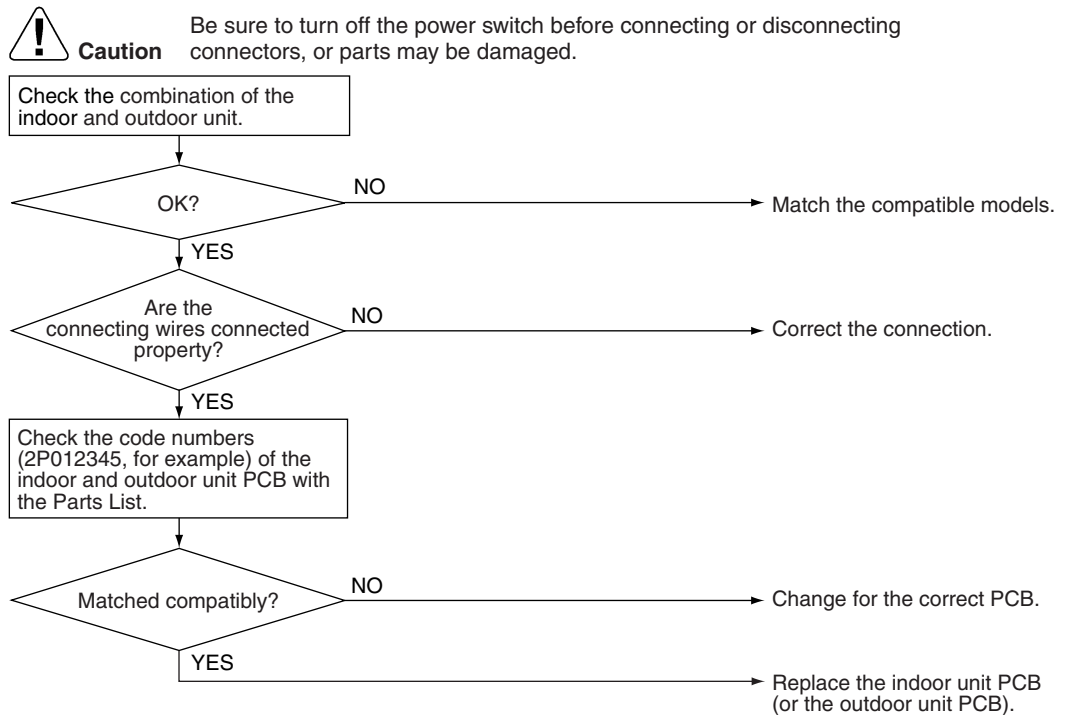

(R19506)

4.11 Outdoor Unit PCB Abnormality

Error Code **E1**

Method of Error Detection

- The system checks if the microprocessor is working in order.
- The system checks if the zero-cross signal comes in properly.

Error Decision Conditions

- The microprocessor program runs out of control.
- The zero-cross signal is not detected.

Supposed Causes

- Defective outdoor unit PCB
- Broken harness between PCBs
- Noise
- Momentary drop of voltage
- Momentary power failure

Troubleshooting

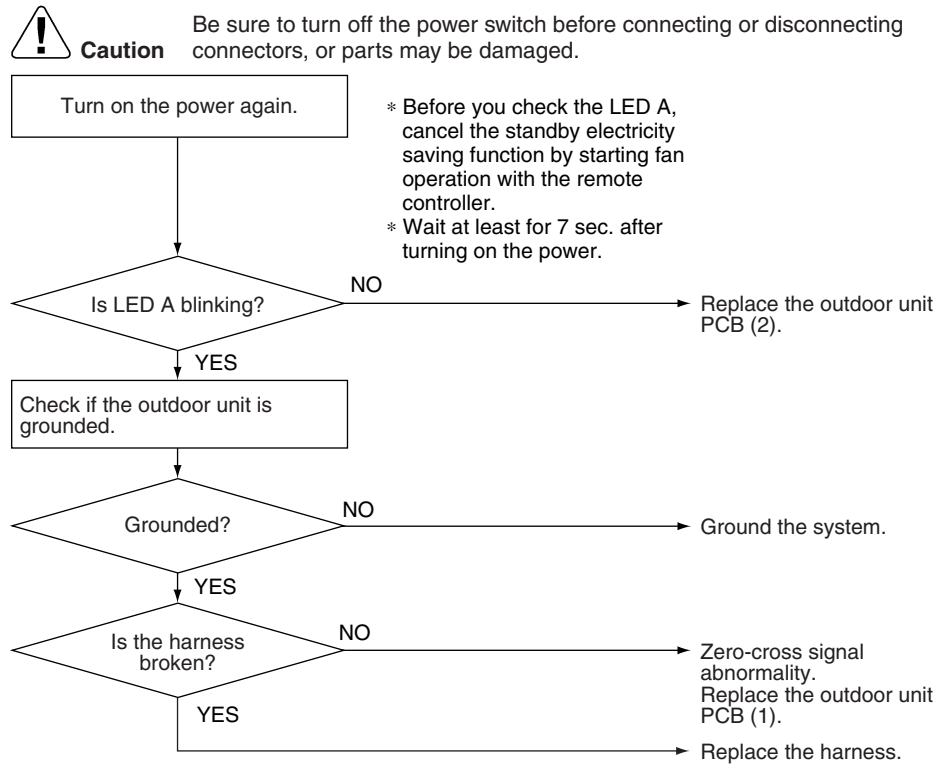

(R19932)

4.12 OL Activation (Compressor Overload)

Error Code	E5
Method of Error Detection	A compressor overload is detected through compressor OL.
Error Decision Conditions	<ul style="list-style-type: none">■ If the error repeats, the system is shut down.■ Reset condition: Continuous run for about 60 minutes without any other error
Supposed Causes	<ul style="list-style-type: none">■ Disconnection of discharge pipe thermistor■ Defective discharge pipe thermistor■ Disconnection of connector S40■ Disconnection of 2 terminals of OL (Q1L)■ Defective OL (Q1L)■ Broken OL harness■ Defective electronic expansion valve or coil■ Defective four way valve or coil■ Defective outdoor unit PCB■ Refrigerant shortage■ Water mixed in refrigerant■ Defective stop valve

Troubleshooting

 **Check No.01**
Refer to P.93

 **Check No.12**
Refer to P.94

 **Check No.13**
Refer to P.95

 **Check No.14**
Refer to P.95

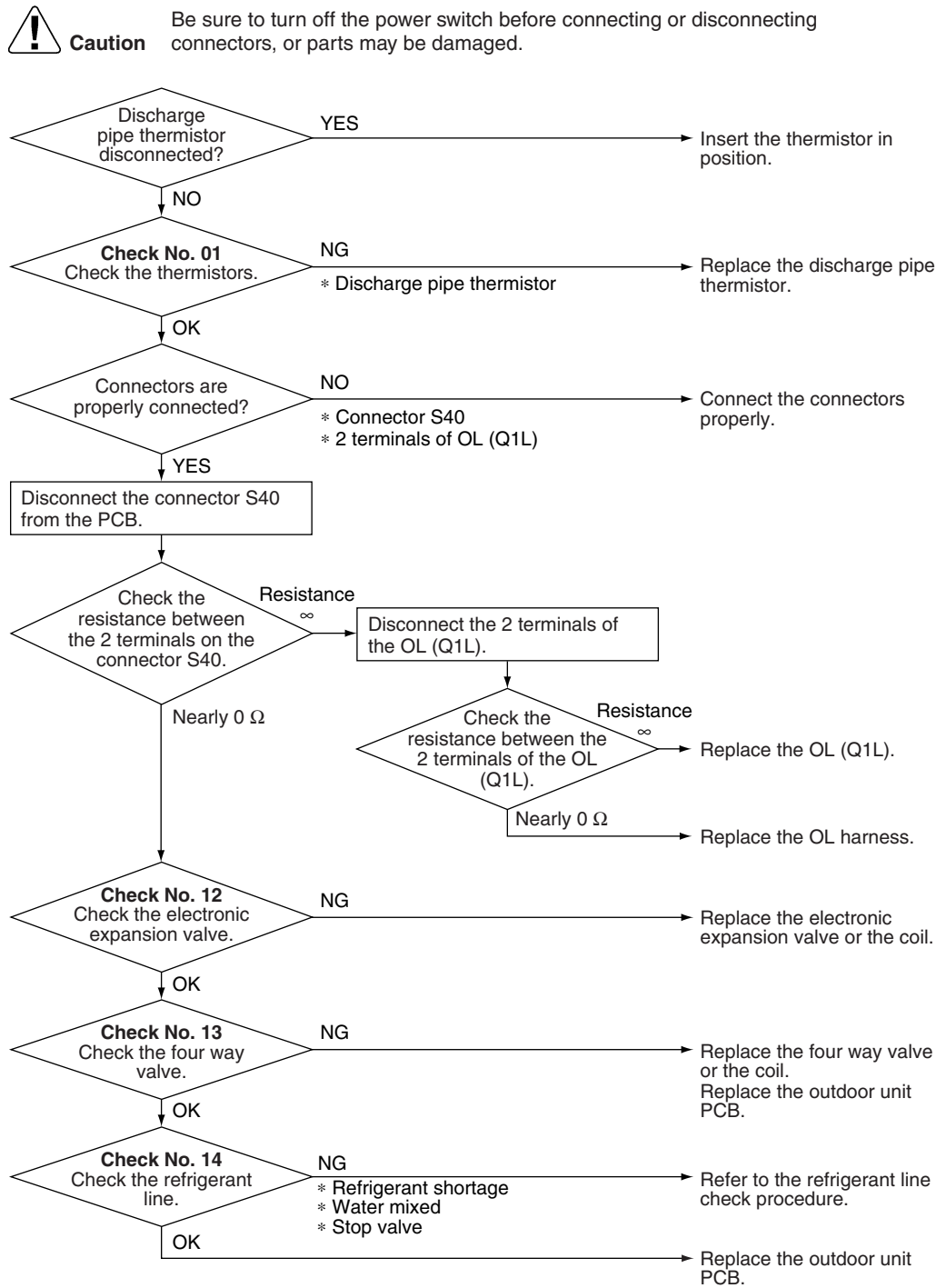

(R19528)

 **Note:** OL (Q1L) activating temperature: 120°C
OL (Q1L) recovery temperature: 95°C

4.13 Compressor Lock

Error Code	EE
Method of Error Detection	A compressor lock is detected by checking the compressor running condition through the position detection circuit.
Error Decision Conditions	<p>20/25/35 class</p> <ul style="list-style-type: none"> ■ Operation stops due to overcurrent. ■ If the error repeats, the system is shut down. ■ Reset condition: Continuous run for about 11 minutes without any other error <p>50 class</p> <ul style="list-style-type: none"> ■ A compressor lock is detected by the current waveform generated when applying high-frequency voltage to the motor. ■ If the error repeats, the system is shut down. ■ Reset condition: Continuous run for about 5 minutes without any other error
Supposed Causes	<ul style="list-style-type: none"> ■ Compressor locked ■ Compressor harness disconnected

Troubleshooting

Check No.15
 Refer to P.96

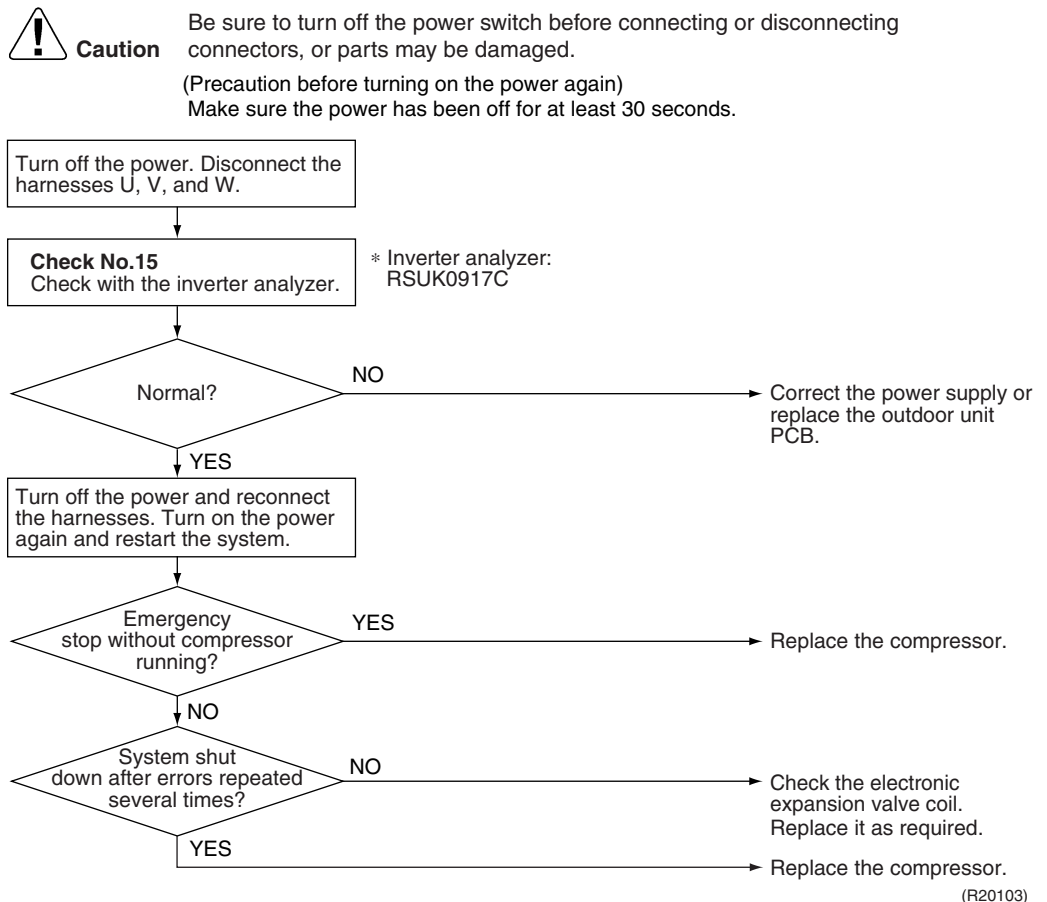

4.14 DC Fan Lock

Error Code	E7
Method of Error Detection	An error is determined with the high-voltage fan motor rotation speed detected by the Hall IC.
Error Decision Conditions	<ul style="list-style-type: none"> ■ The fan does not start in about 15 ~ 30 seconds even when the fan motor is running. ■ If the error repeats, the system is shut down. ■ Reset condition: Continuous run for about 11 minutes (20/25/35 class) or 5 minutes (50 class) without any other error
Supposed Causes	<ul style="list-style-type: none"> ■ Disconnection of the fan motor ■ Foreign matter stuck in the fan ■ Defective fan motor ■ Defective outdoor unit PCB

Troubleshooting

Check No.16
 Refer to P.97

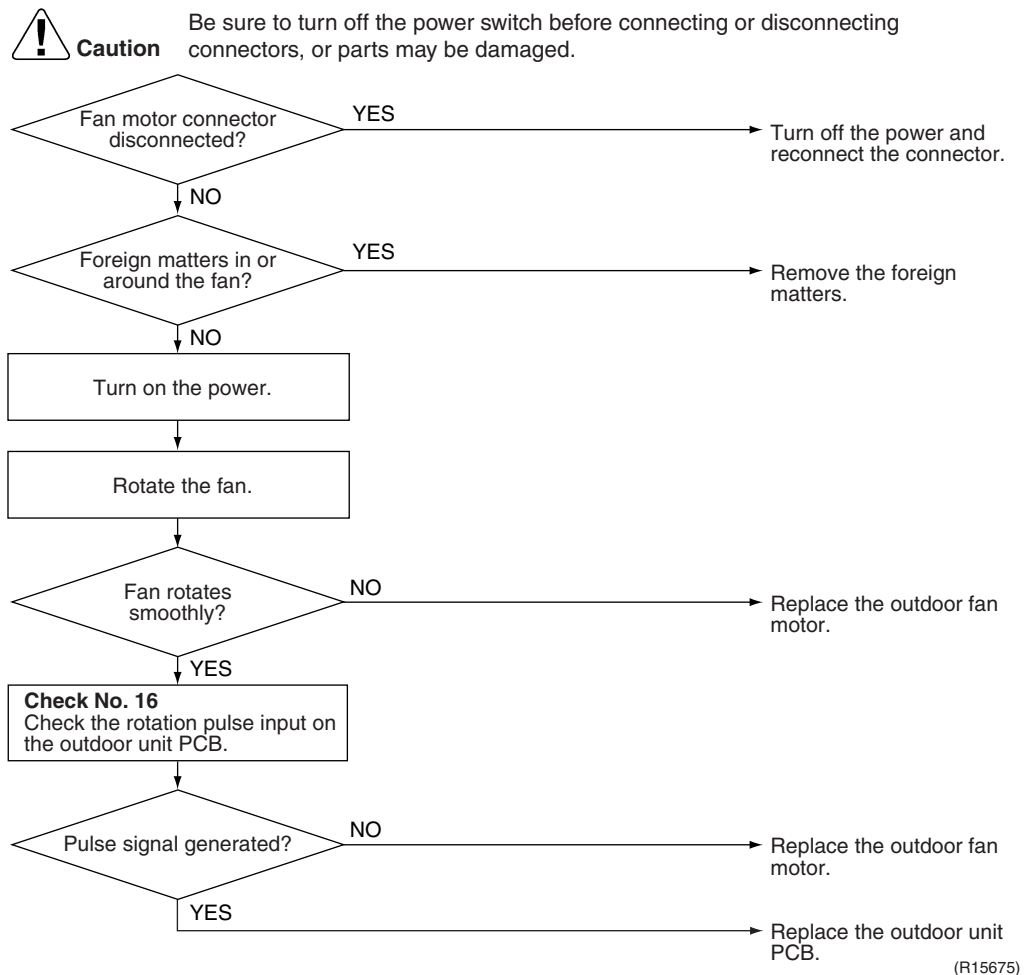

4.15 Input Overcurrent Detection

Error Code	E8
Method of Error Detection	An input overcurrent is detected by checking the input current value with the compressor running.
Error Decision Conditions	The current exceeds about 9.25 ~ 20 A (depending on the model) for 2.5 seconds with the compressor running. (The upper limit of the current decreases when the outdoor temperature exceeds a certain level.)
Supposed Causes	<ul style="list-style-type: none"> ■ Outdoor temperature is out of operation range. ■ Defective compressor ■ Defective power module ■ Defective outdoor unit PCB ■ Short circuit

Troubleshooting

Check No.15
 Refer to P.96

Check No.17
 Refer to P.98

Check No.18
 Refer to P.99

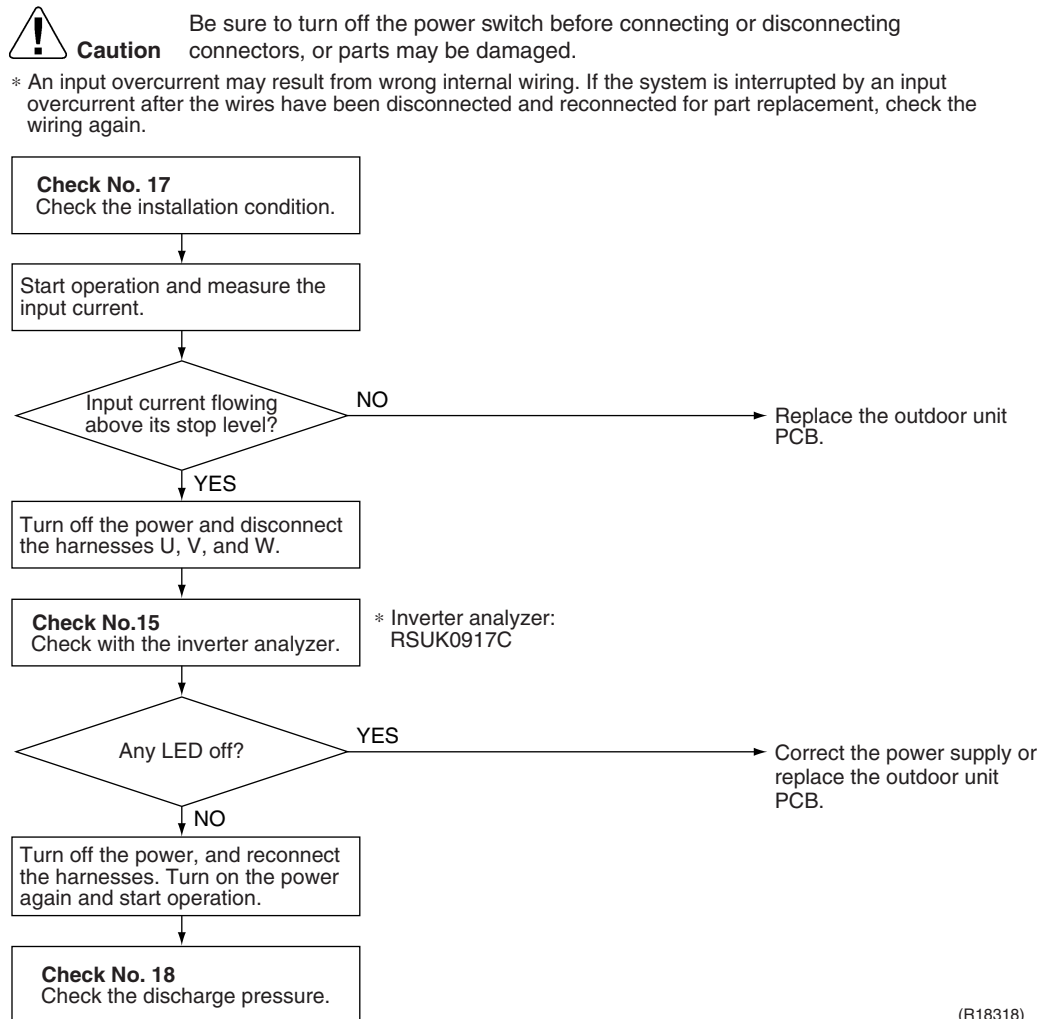

(R18318)

4.16 Four Way Valve Abnormality

Error Code	E8
Method of Error Detection	The room temperature thermistor and the indoor heat exchanger thermistor are checked if they function within their normal ranges in each operation mode.
Error Decision Conditions	<p>A following condition continues over 1 ~ 10 minutes (depending on the model) after operating for 5 ~ 10 minutes (depending on the model).</p> <p>< Cooling / Dry > A – B < –5°C</p> <p>< Heating > B – A < –5°C</p> <p>A: Room thermistor temperature B: Indoor heat exchanger temperature</p> <ul style="list-style-type: none"> ■ If the error repeats, the system is shut down. ■ Reset condition: Continuous run for about 60 minutes without any other error
Supposed Causes	<ul style="list-style-type: none"> ■ Disconnection of four way valve coil ■ Defective four way valve, coil, or harness ■ Defective outdoor unit PCB ■ Defective thermistor ■ Refrigerant shortage ■ Water mixed in refrigerant ■ Defective stop valve

Troubleshooting

Check No.01
 Refer to P.93

Check No.13
 Refer to P.95

Check No.14
 Refer to P.95

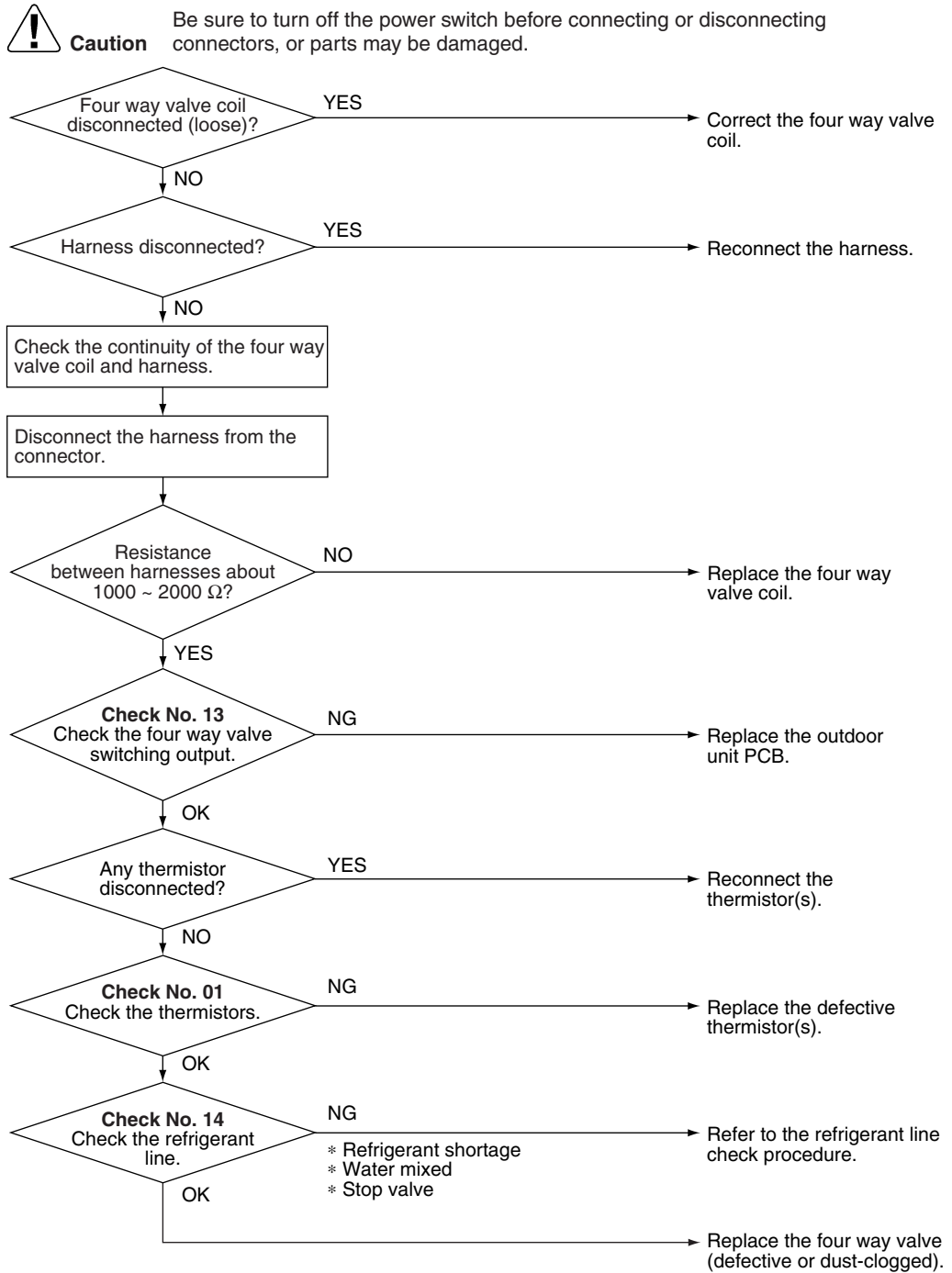

(R19543)

4.17 Discharge Pipe Temperature Control

Error Code **F3**

Method of Error Detection

An error is determined with the temperature detected by the discharge pipe thermistor.

Error Decision Conditions

- If the temperature detected by the discharge pipe thermistor rises above **A**°C, the compressor stops.
- The error is cleared when the discharge pipe temperature has dropped below **B**°C.

<20/25/35 class>

	A (°C)	B (°C)
(1) above 45 Hz (rising), above 40 Hz (dropping)	110	97
(2) 30 ~ 45 Hz (rising), 25 ~ 40 Hz (dropping)	105	92
(3) below 30 Hz (rising), below 25 Hz (dropping)	99	86

<50 class>

A (°C)	B (°C)
110	95

- If the error repeats, the system is shut down.
- Reset condition: Continuous run for about 60 minutes without any other error

Supposed Causes

- Defective discharge pipe thermistor
(Defective outdoor heat exchanger thermistor or outdoor temperature thermistor)
- Defective electronic expansion valve or coil
- Refrigerant shortage
- Defective four way valve
- Water mixed in refrigerant
- Defective stop valve
- Defective outdoor unit PCB

Troubleshooting

Check No.01
 Refer to P.93

Check No.12
 Refer to P.94

Check No.14
 Refer to P.95

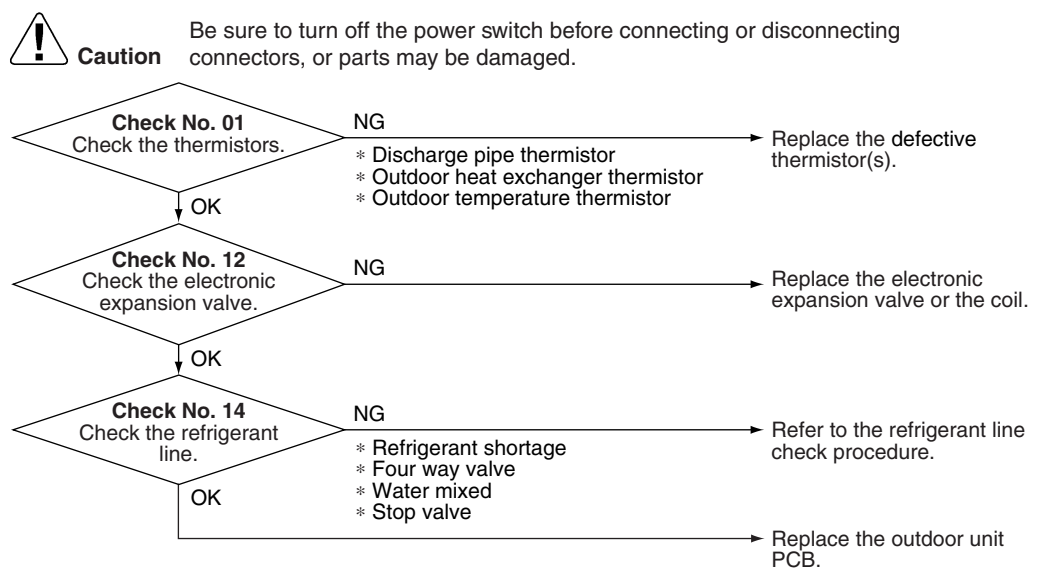





(R15825)

4.18 High Pressure Control in Cooling

Error Code	F6
Method of Error Detection	High-pressure control (operation halt, frequency drop, etc.) is activated in cooling operation if the temperature sensed by the outdoor heat exchanger thermistor exceeds the limit.
Error Decision Conditions	<ul style="list-style-type: none"> ■ The temperature sensed by the outdoor heat exchanger thermistor rises above about 60 ~ 65°C (depending on the model). ■ The error is cleared when the temperature drops below about 50°C.
Supposed Causes	<ul style="list-style-type: none"> ■ The installation space is not large enough. ■ Dirty outdoor heat exchanger ■ Defective outdoor fan motor ■ Defective stop valve ■ Defective electronic expansion valve or coil ■ Defective outdoor heat exchanger thermistor ■ Defective outdoor unit PCB

Troubleshooting

-  **Check No.01**
Refer to P.93
-  **Check No.12**
Refer to P.94
-  **Check No.17**
Refer to P.98
-  **Check No.18**
Refer to P.99
-  **Check No.19**
Refer to P.99

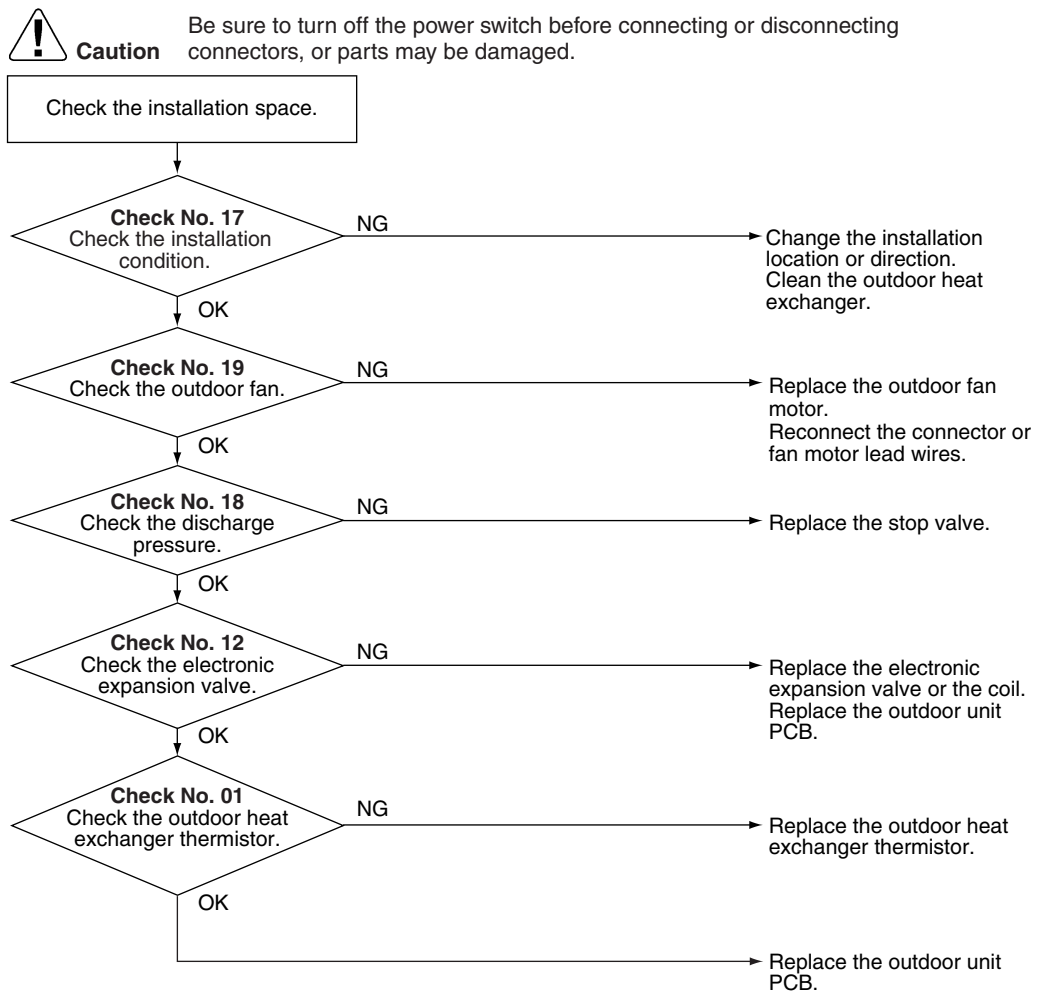

(R15667)

4.19 Compressor System Sensor Abnormality

Error Code	H0
Method of Error Detection	The system checks the DC current before the compressor starts.
Error Decision Conditions	<ul style="list-style-type: none"> ■ The DC current before compressor start-up is out of the range 0.5 ~ 4.5 V (sensor output converted to voltage value) ■ The DC voltage before compressor start-up is below 50 V.
Supposed Causes	<ul style="list-style-type: none"> ■ Broken or disconnected harness ■ Defective outdoor unit PCB
Troubleshooting	

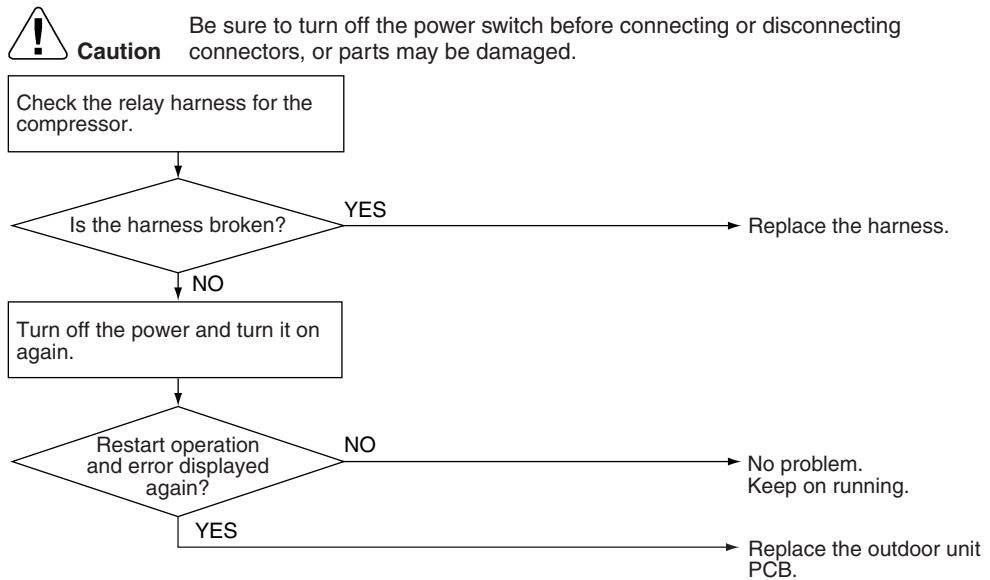

(R11712)

4.20 Position Sensor Abnormality

Error Code	H6
Method of Error Detection	A compressor start-up failure is detected by checking the compressor running condition through the position detection circuit.
Error Decision Conditions	<ul style="list-style-type: none">■ If the error repeats, the system is shut down.■ Reset condition: Continuous run for about 11 minutes (20/25/35 class) or 5 minutes (50 class) without any other error
Supposed Causes	<ul style="list-style-type: none">■ Disconnection of the compressor relay cable■ Defective compressor■ Defective outdoor unit PCB■ Start-up failure caused by the closed stop valve■ Input voltage is outside the specified range.

Troubleshooting

Check No.15
 Refer to P.96

Check No.18
 Refer to P.99

Check No.20
 Refer to P.100

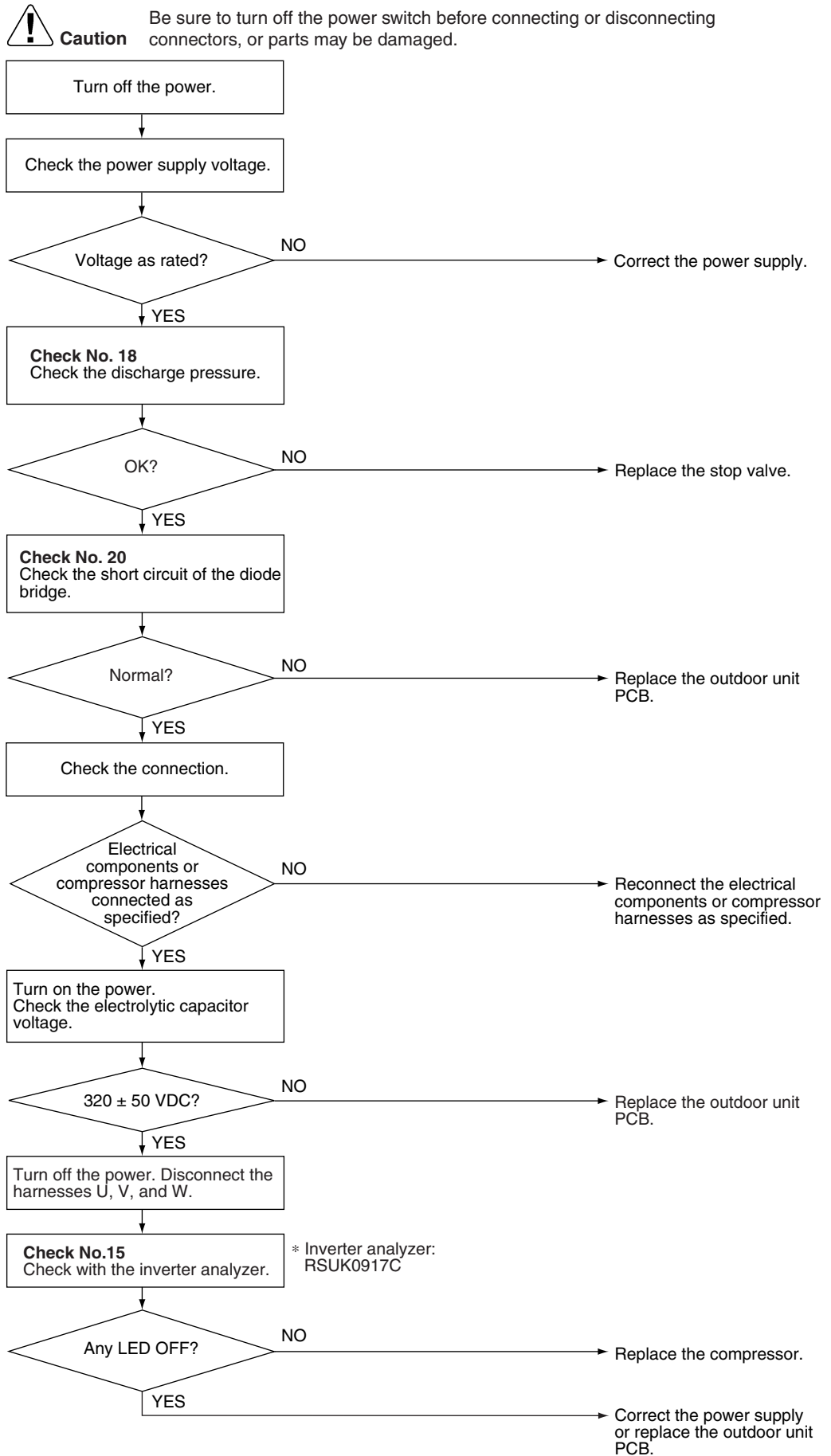

(R19184)

4.21 DC Voltage / Current Sensor Abnormality (20/25/35 Class Only)

Error Code

H0

Method of Error Detection

DC voltage or DC current sensor abnormality is identified based on the compressor running frequency and the input current.

Error Decision Conditions

- If the error repeats, the system is shut down.
- Reset condition: Continuous run for about 60 minutes without any other error

Supposed Causes

- Defective outdoor unit PCB

Troubleshooting



Caution

Be sure to turn off the power switch before connecting or disconnecting connectors, or parts may be damaged.

Replace the outdoor unit PCB.

4.22 Thermistor or Related Abnormality (Outdoor Unit)

Error Code	49, 43, 46, P4
Method of Error Detection	This fault is identified based on the thermistor input voltage to the microcomputer. A thermistor fault is identified based on the temperature sensed by each thermistor.
Error Decision Conditions	<ul style="list-style-type: none"> ■ The thermistor input voltage is 4.96 V and more or 0.04 V and less with the power on. ■ 43 error is judged if the discharge pipe temperature is lower than the heat exchanger temperature.
Supposed Causes	<ul style="list-style-type: none"> ■ Disconnection of the connector for the thermistor ■ Thermistor corresponding to the error code is defective. ■ Defective heat exchanger thermistor in the case of 43 error (outdoor heat exchanger thermistor in cooling operation, or indoor heat exchanger thermistor in heating operation) ■ Defective outdoor unit PCB
Troubleshooting	<p>In case of P4</p> <p> Caution Be sure to turn off the power switch before connecting or disconnecting connectors, or parts may be damaged.</p> <p>Replace the outdoor unit PCB.</p> <p>P4 : Radiation fin thermistor</p>

Troubleshooting

In case of *H9*, *J3*, *J6*

Check No.01
 Refer to P.93



Caution

Be sure to turn off the power switch before connecting or disconnecting connectors, or parts may be damaged.

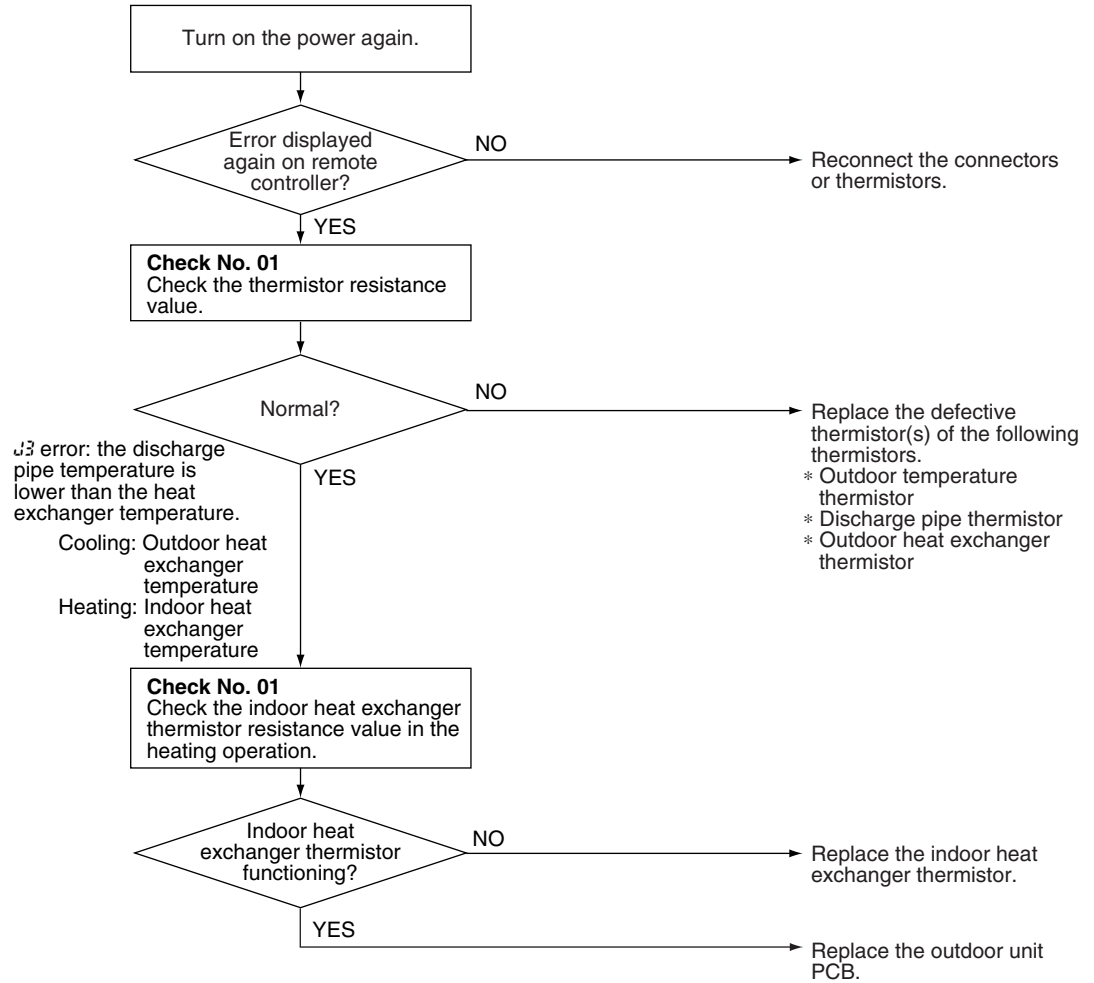

J3 error: the discharge pipe temperature is lower than the heat exchanger temperature.
 Cooling: Outdoor heat exchanger temperature
 Heating: Indoor heat exchanger temperature



(R16059)

H9 : Outdoor temperature thermistor
J3 : Discharge pipe thermistor
J6 : Outdoor heat exchanger thermistor

4.23 Electrical Box Temperature Rise

Error Code	E3		
Method of Error Detection	An electrical box temperature rise is detected by checking the radiation fin thermistor with the compressor off.		
Error Decision Conditions	<ul style="list-style-type: none"> ■ With the compressor off, the radiation fin temperature is above A°C. ■ The error is cleared when the radiation fin temperature drops below B°C. ■ To cool the electrical components, the outdoor fan starts when the radiation fin temperature rises above C°C and stops when it drops below B°C. 		
	A (°C)	B (°C)	C (°C)
20/25/35 class	98	75	83
50 class	122	64	113
Supposed Causes	<ul style="list-style-type: none"> ■ Defective outdoor fan motor ■ Short circuit ■ Defective radiation fin thermistor ■ Disconnection of connector ■ Defective outdoor unit PCB 		

Troubleshooting

-  **Check No.17**
Refer to P.98
-  **Check No.19**
Refer to P.99

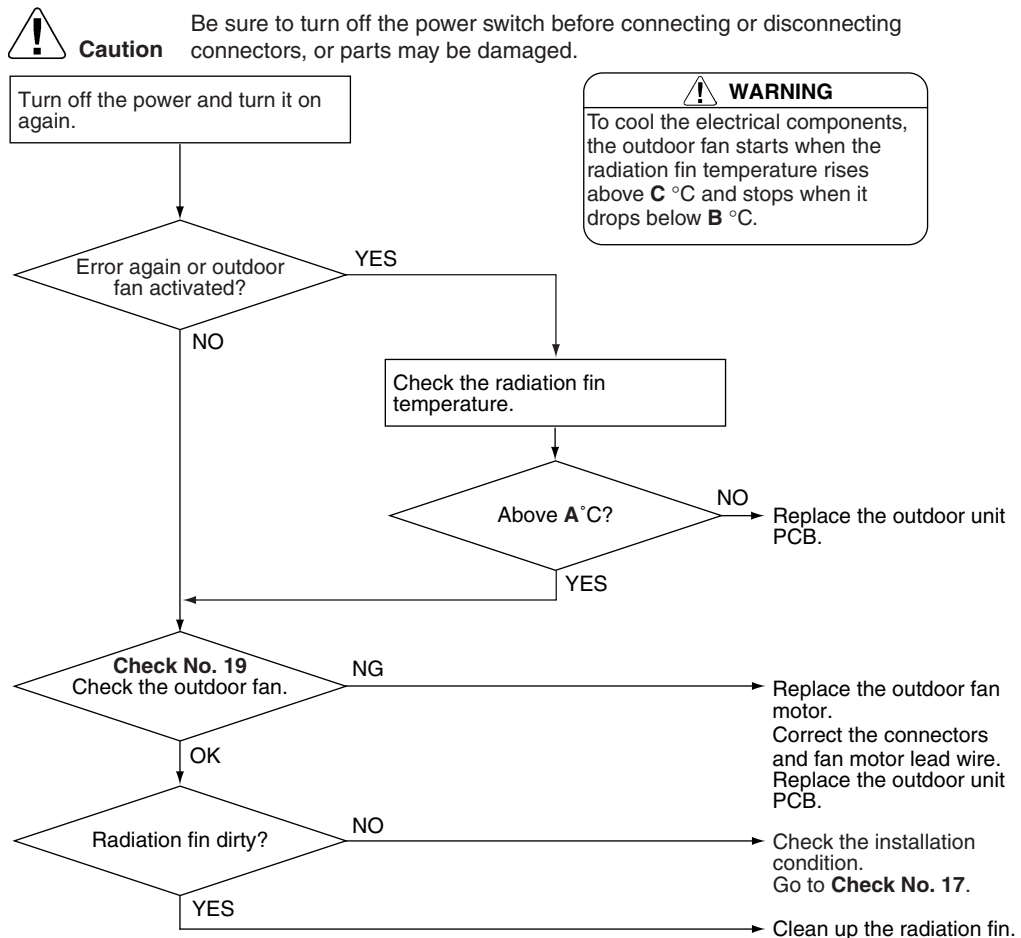

(R19556)

4.24 Radiation Fin Temperature Rise

Error Code L4

Method of Error Detection A radiation fin temperature rise is detected by checking the radiation fin thermistor with the compressor on.

- Error Decision Conditions**
- If the radiation fin temperature with the compressor on is above **A**°C.
 - The error is cleared when the radiation fin temperature drops below **B**°C.
 - If the error repeats, the system is shut down.
 - Reset condition: Continuous run for about 60 minutes without any other error

	A (°C)	B (°C)
20/25/35 class	98	78
50 class	85	56

- Supposed Causes**
- Defective outdoor fan motor
 - Short circuit
 - Defective radiation fin thermistor
 - Disconnection of connector
 - Defective outdoor unit PCB
 - Silicon grease is not applied properly on the radiation fin after replacing the outdoor unit PCB.

Troubleshooting

 **Check No.17**
Refer to P.98

 **Check No.19**
Refer to P.99

 **Caution** Be sure to turn off the power switch before connecting or disconnecting connectors, or parts may be damaged.

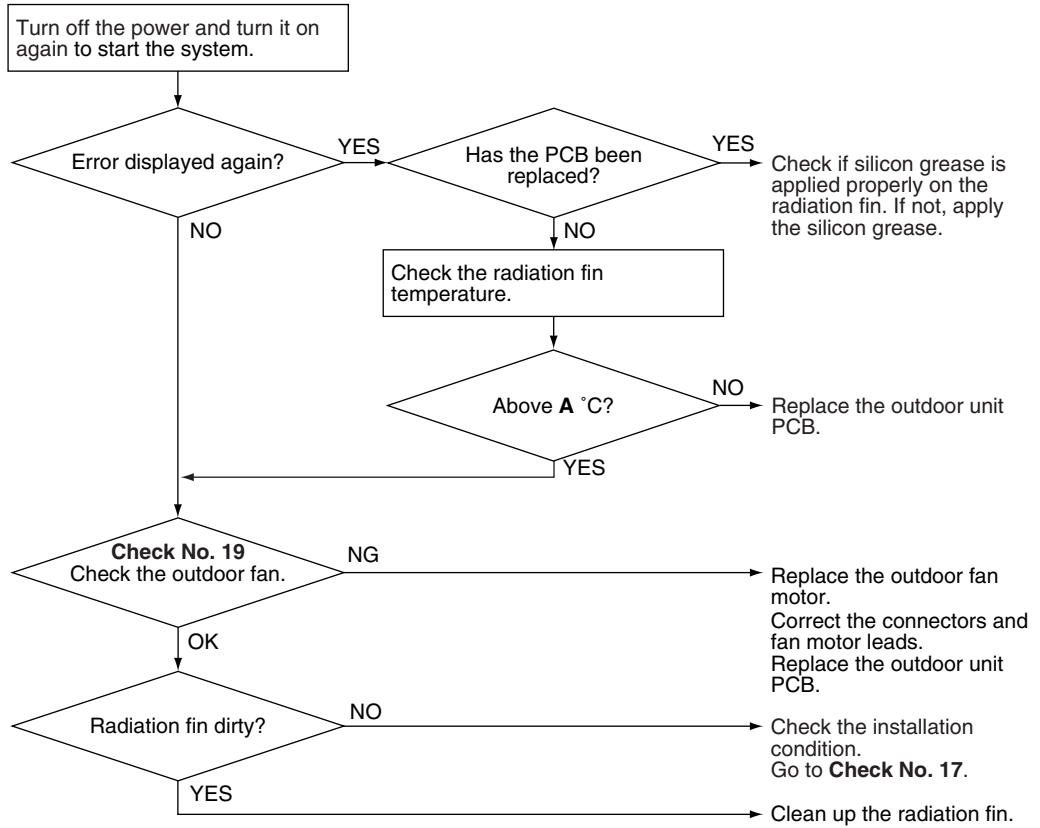

(R19529)

	A (°C)
20/25/35 class	98
50 class	85

 **Note:** Refer to Silicon Grease on Power Transistor / Diode Bridge on page 110 for detail.

4.25 Output Overcurrent Detection

Error Code	L5
Method of Error Detection	An output overcurrent is detected by checking the current that flows in the inverter DC section.
Error Decision Conditions	<ul style="list-style-type: none"> ■ A position signal error occurs while the compressor is running. ■ A speed error occurs while the compressor is running. ■ An output overcurrent signal is fed from the output overcurrent detection circuit to the microcomputer. ■ If the error repeats, the system is shut down. ■ Reset condition: Continuous run for about 11 minutes (20/25/35 class) or 5 minutes (50 class) without any other error
Supposed Causes	<ul style="list-style-type: none"> ■ Poor installation condition ■ Closed stop valve ■ Defective power module ■ Wrong internal wiring ■ Abnormal power supply voltage ■ Defective outdoor unit PCB ■ Defective compressor

Troubleshooting



Check No.15
Refer to P.96



Check No.17
Refer to P.98



Check No.18
Refer to P.99



Check No.22
Refer to P.101



Caution

Be sure to turn off the power switch before connecting or disconnecting connectors, or parts may be damaged.

* An output overcurrent may result from wrong internal wiring. If the system is interrupted by an output overcurrent after the wires have been disconnected and reconnected for part replacement, check the wiring again.

Check No. 17
Check the installation condition.

Stop valve fully open?
NO
YES

Fully open the stop valve.

Turn off the power and turn it on again to start the system. See if the same error occurs.

Error again?
NO
YES

Monitor the power supply voltage, discharge and suction pressures, and other factors for a long term.

Possible causes
* Momentary drop of power supply voltage
* Compressor overload
* Short circuit

Keep on using.

Check the connectors and other components.

Turn off the power and disconnect the harnesses U, V, and W.

Check No.15
Check with the inverter analyzer.

* Inverter analyzer:
RSUK0917C

Any LED off?
YES
NO

Correct the power supply or replace the outdoor unit PCB.

Check No. 22
Check the power module.

Normal?
NO
YES

Replace the outdoor unit PCB.

Turn off the power, and reconnect the harnesses. Turn on the power again and start operation.

Check the power supply voltage.

Voltage as rated?
NO
YES

Correct the power supply.

Short circuit or wire breakage between compressor's coil phases?
NO
YES

Check the discharge pressure. Go to **Check No. 18.**

Replace the compressor.

(R19545)

5. Check

5.1 Thermistor Resistance Check

Check No.01

Disconnect the connectors of the thermistors from the PCB, and measure the resistance of each thermistor using a multimeter.

The data is for reference purpose only.

Thermistor temperature (°C)	Resistance (kΩ)
-20	197.8
-15	148.2
-10	112.1
-5	85.60
0	65.93
5	51.14
10	39.99
15	31.52
20	25.02
25	20.00
30	16.10
35	13.04
40	10.62
45	8.707
50	7.176

($R_{25^{\circ}\text{C}} = 20 \text{ k}\Omega$, $B = 3950 \text{ K}$)

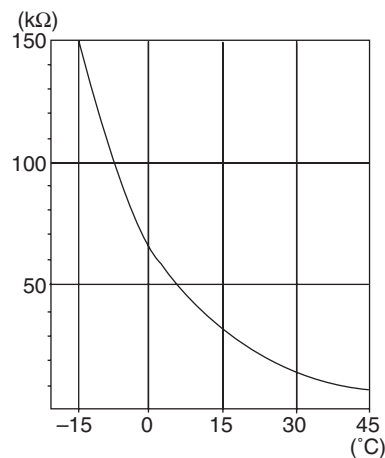

(R11905)

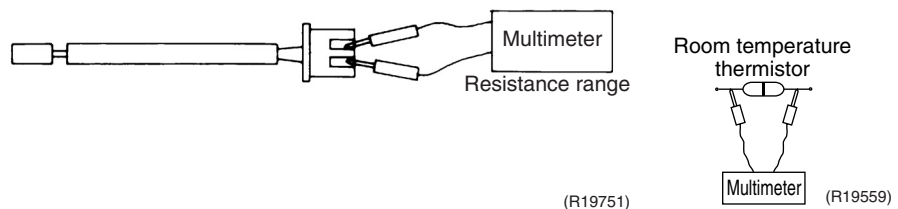

- When the room temperature thermistor is soldered on a PCB, remove the PCB from the control PCB to measure the resistance.
- When the connector of indoor heat exchanger thermistor is soldered on a PCB, remove the thermistor and measure the resistance.

5.2 Fan Motor Connector Output Check

Check No.02

1. Check the connection of connector.
2. Check the motor power supply voltage output (pins 4 - 7).
3. Check the motor control voltage (pins 4 - 3).
4. Check the rotation command voltage (pins 4 - 2).
5. Check the rotation pulse (pins 4 - 1).

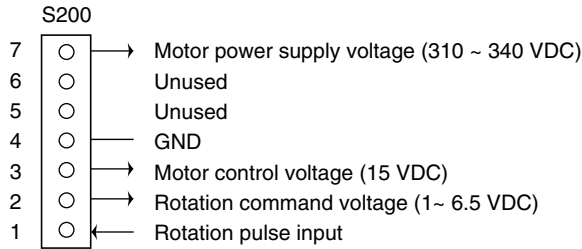

(R19942)

5.3 Power Supply Waveforms Check

Check No.11

Measure the power supply waveform between No. 1 and No. 2 on the terminal board, and check the waveform disturbance.

- Check if the power supply waveform is a sine wave (Fig.1).
- Check if there is waveform disturbance near the zero cross (sections circled in Fig.2).

Fig.1

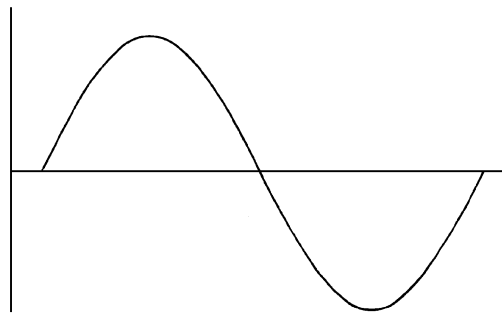

(R1736)

Fig.2

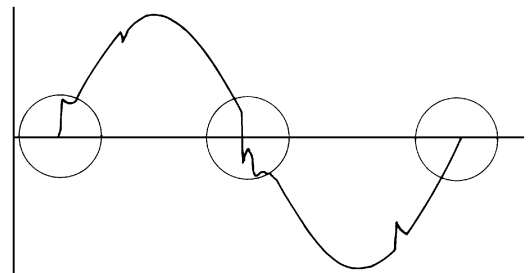

(R1444)

5.4 Electronic Expansion Valve Check

Check No.12

Conduct the followings to check the electronic expansion valve (EV).

1. Check if the EV connector is correctly connected to the PCB.
2. Turn the power off and on again, and check if the EV generates a latching sound.
3. If the EV does not generate a latching sound in the above step 2, disconnect the connector and check the continuity using a multimeter.
4. Check the continuity between the pins 1 - 6, 2 - 6, 3 - 6, 4 - 6. If there is no continuity between the pins, the EV coil is faulty.
5. If the continuity is confirmed in step 3, the outdoor unit PCB is faulty.

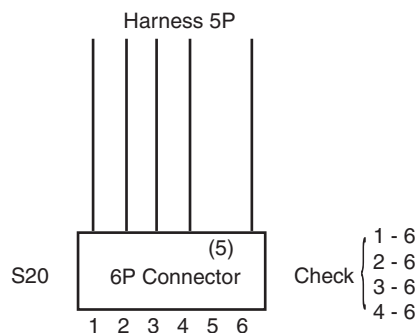

(R16386)

5.5 Four Way Valve Performance Check

Check No.13

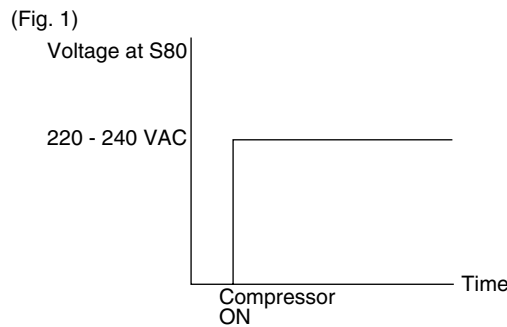
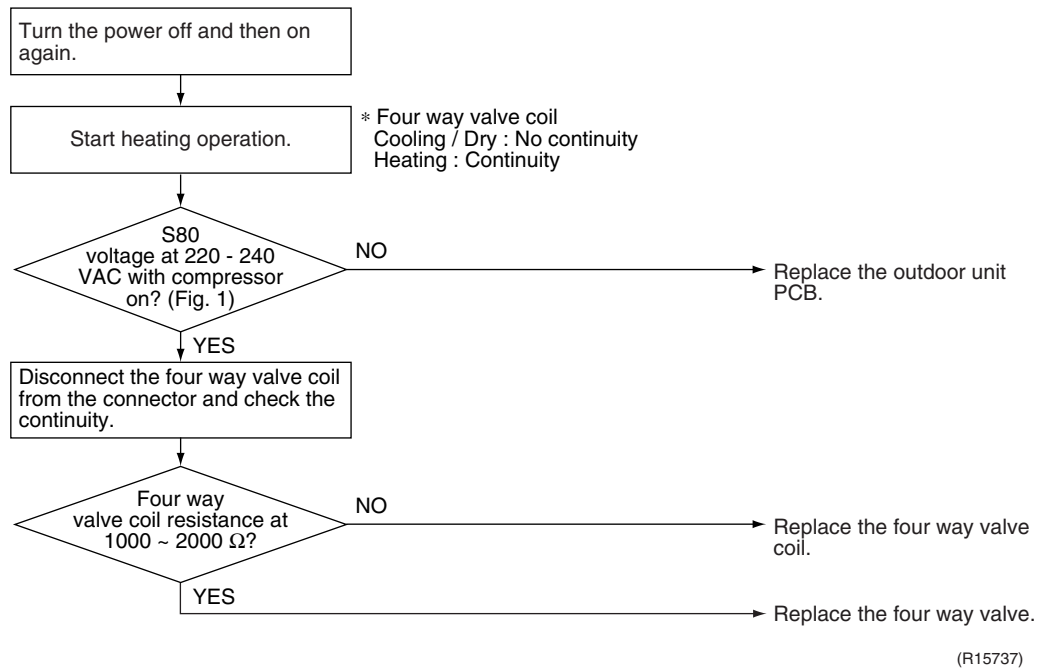

5.6 Inverter Unit Refrigerant System Check

Check No.14

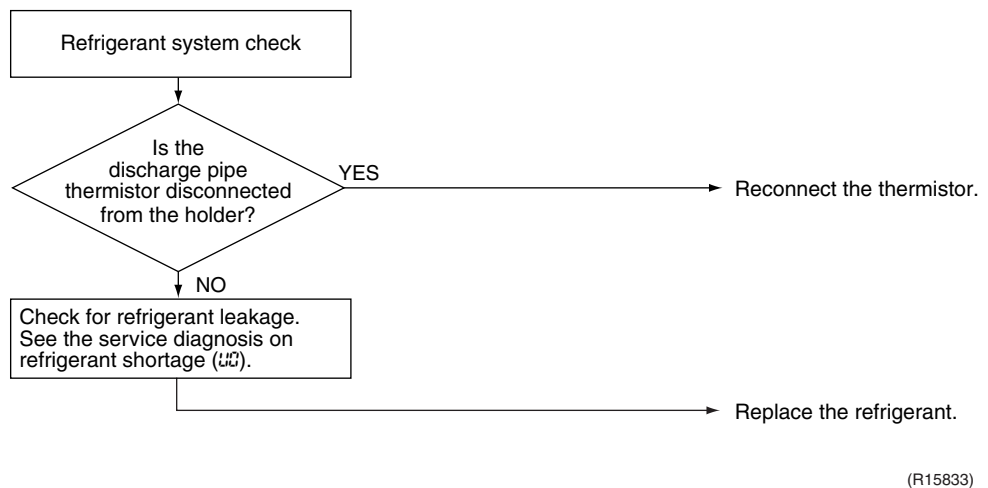

5.7 Inverter Analyzer Check

Check No.15

■ Characteristics

Inverter analyzer: RSUK0917C

If an abnormal stop occurs due to compressor startup failure or overcurrent output when using an inverter unit, it is difficult to judge whether the stop is caused by the compressor failure or some other failure (main PCB, power module, etc.). The inverter analyzer makes it possible to judge the cause of trouble easily and securely. (Connect an inverter analyzer as a quasi-compressor instead of compressor and check the output of the inverter)

■ Operation Method

Step 1

Be sure to turn the power off.

Step 2

Install an inverter analyzer instead of a compressor.

Note:

Make sure the charged voltage of the built-in smoothing electrolytic capacitor drops to 10 VDC or below before carrying out the service work.

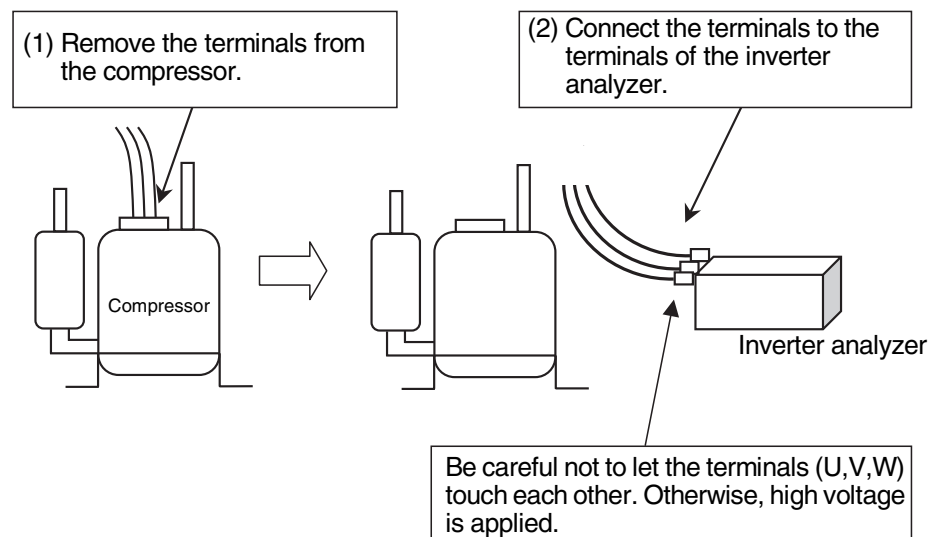

Reference:

If the terminals of the compressor are not FASTON terminals (difficult to remove the wire on the terminals), it is possible to connect wires available on site to the outdoor unit from output side of PCB. (Do not connect them to the compressor at the same time, otherwise it may result in incorrect detection.)

Step 3

Activate the power transistor test operation from the outdoor unit.

1) Press the forced cooling operation **ON/OFF** button for 5 seconds.

(Refer to page 104 for the position.)

→ Power transistor test operation starts.

■ **Diagnose method (Diagnose according to 6 LEDs lighting status.)**

- (1) If all the LEDs are lit uniformly, the compressor is defective.
→ Replace the compressor.
- (2) If the LEDs are not lit uniformly, check the power module.
→ Refer to **Check No.22**.
- (3) If NG in **Check No.22**, replace the power module.
(Replace the main PCB. The power module is united with the main PCB.)
If OK in **Check No.22**, check if there is any solder cracking on the PCB.
- (4) If any solder cracking is found, replace the PCB or repair the soldered section.
If there is no solder cracking, replace the PCB.



Caution

- (1) When the output frequency is low, the LEDs blink slowly. As the output frequency increases, the LEDs blink quicker. (The LEDs look like they are lit.)
- (2) On completion of the inverter analyzer diagnosis, be sure to re-crimp the FASTON terminals. Otherwise, the terminals may be burned due to loosening.

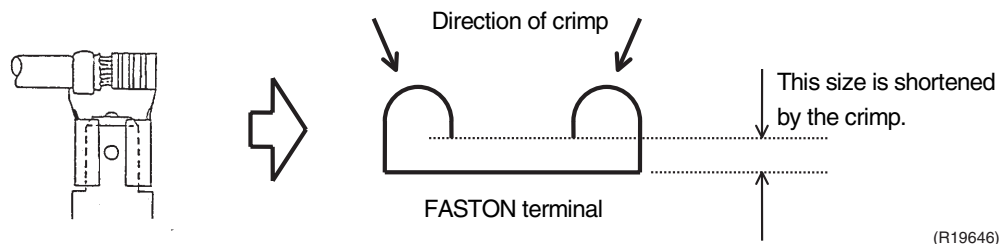

(R19646)

5.8 Rotation Pulse Check on the Outdoor Unit PCB

Check No.16

20/25/35 class

1. Check that the control voltage between the pins 10 - 11 is 15 VDC.
2. Check if the Hall IC generates the rotation pulse (0 ~ 15 VDC) 4 times between the pins 10 - 12, 10 - 13, when the fan motor is manually rotated once.

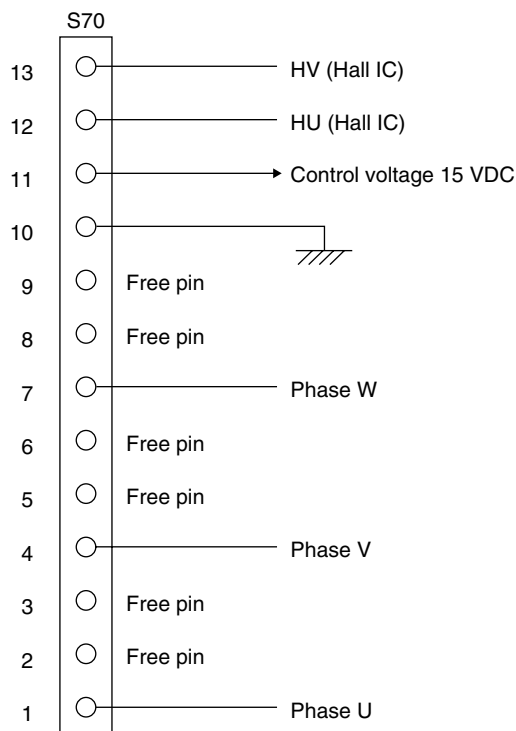

(R19957)

50 class

Make sure that the voltage of 320 ± 30 V is applied.

1. Set operation off and power off. Disconnect the connector S70.
2. Check that the voltage between the pins 4 - 7 is 320 VDC.
3. Check that the control voltage between the pins 3 - 4 is 15 VDC.
4. Check that the rotation command voltage between the pins 2 - 4 is 0 ~ 6.5 VDC.
5. Keep operation off and power off. Connect the connector S70.
6. Check whether 4 rotation pulses (0 ~ 15 VDC) are input at the pins 1 - 4 when the fan motor is rotated 1 turn by hand.

When the fuse is melted, check the outdoor fan motor for proper function.

If NG in step 2 → Defective PCB → Replace the outdoor unit PCB.

If NG in step 4 → Defective Hall IC → Replace the outdoor fan motor.

If OK in both steps 2 and 4 → Replace the outdoor unit PCB.

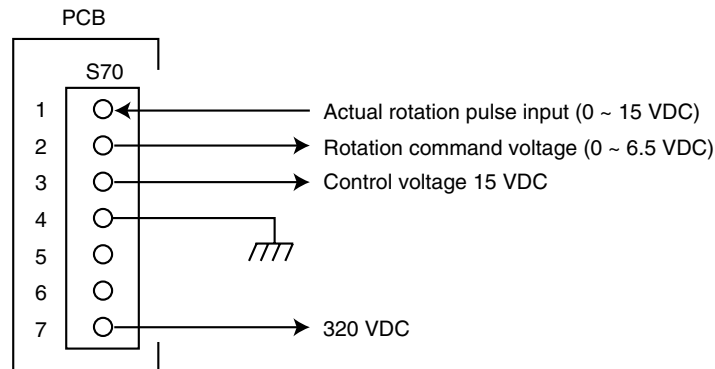

(R19655)

5.9 Installation Condition Check

Check No.17

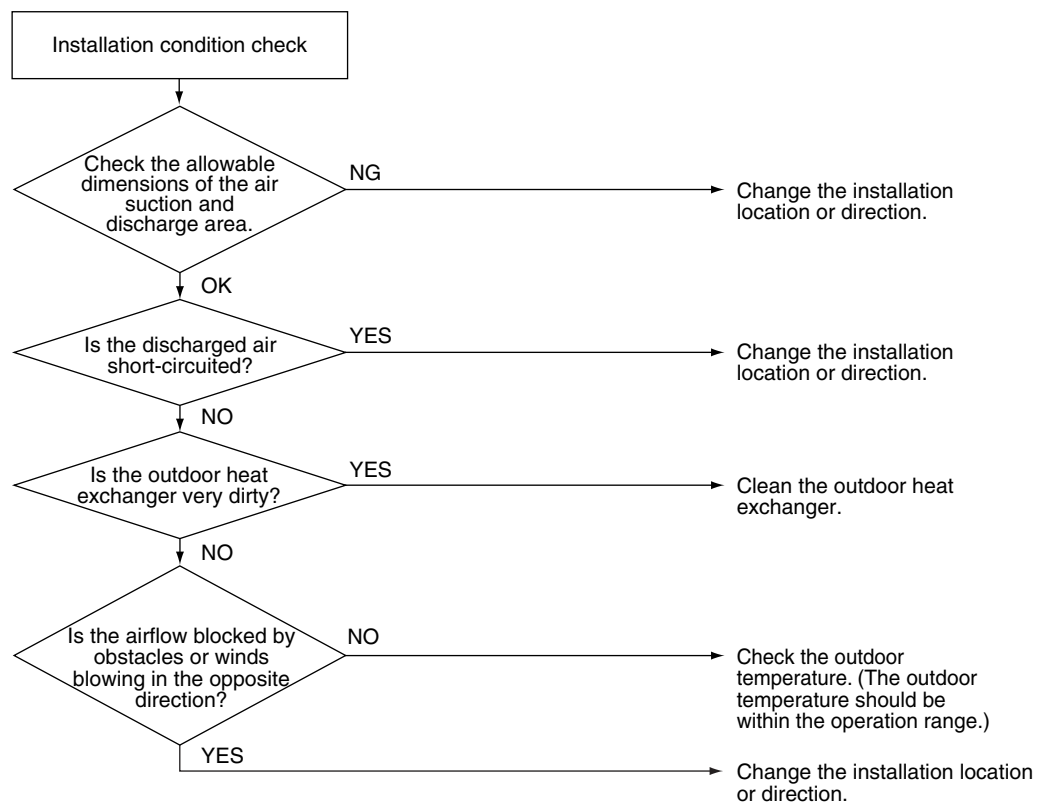

(R19401)

5.10 Discharge Pressure Check

Check No.18

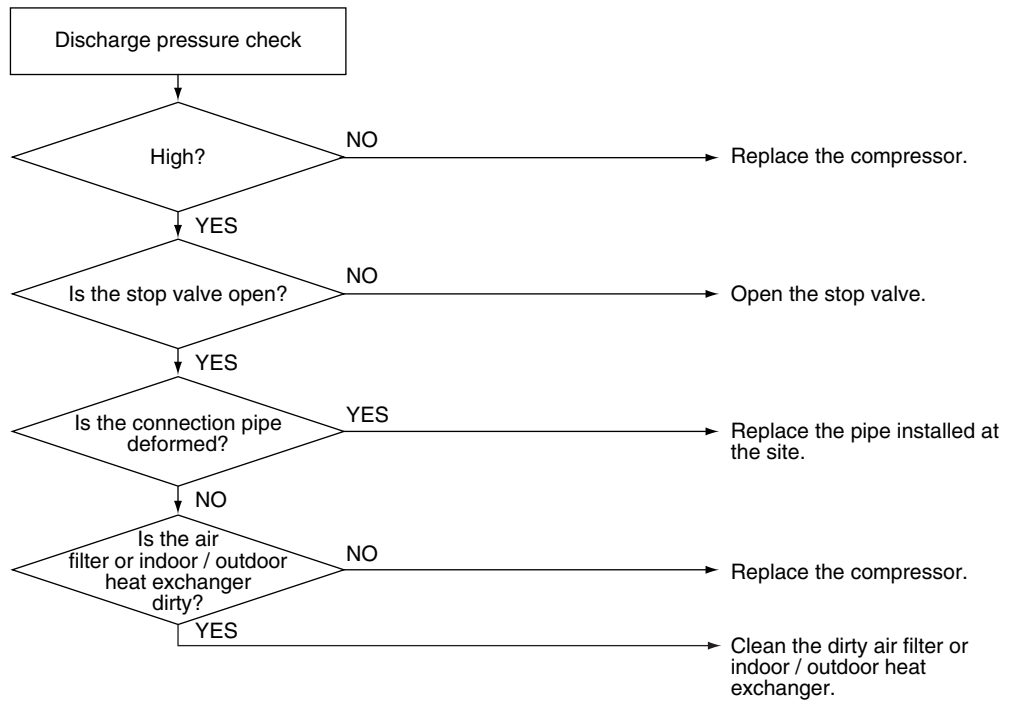

(R19385)

5.11 Outdoor Fan System Check

Check No.19

DC motor

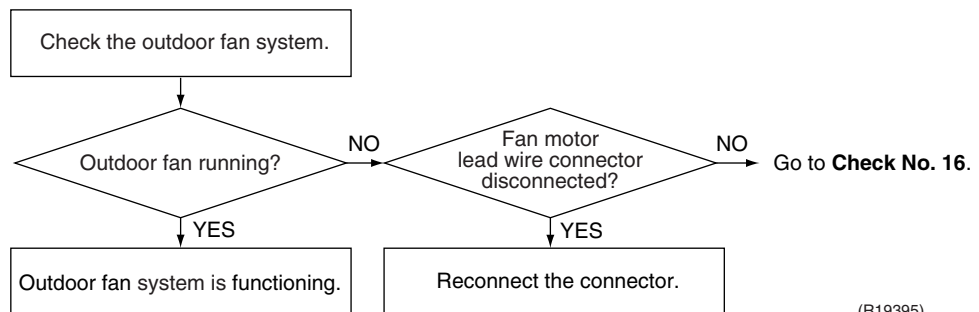

(R19395)

5.12 Main Circuit Short Check

Check No.20



Note: Check to make sure that the voltage between (+) and (-) of the diode bridge (DB1) is approximately 0 V before checking.

- Measure the resistance between the pins of the DB1 referring to the table below.
- If the resistance is ∞ or less than 1 kW, short circuit occurs on the main circuit.

Negative (-) terminal of multimeter (positive terminal (+) for digital multimeter)	~ (2, 3)	+ (4)	~ (2, 3)	- (1)
Positive (+) terminal of multimeter (negative terminal (-) for digital multimeter)	+ (4)	~ (2, 3)	- (1)	~ (2, 3)
Resistance is OK.	several kΩ ~ several MΩ	∞	∞	several kΩ ~ several MΩ
Resistance is NG.	0 Ω or ∞	0	0	0 Ω or ∞

20/25/35 class

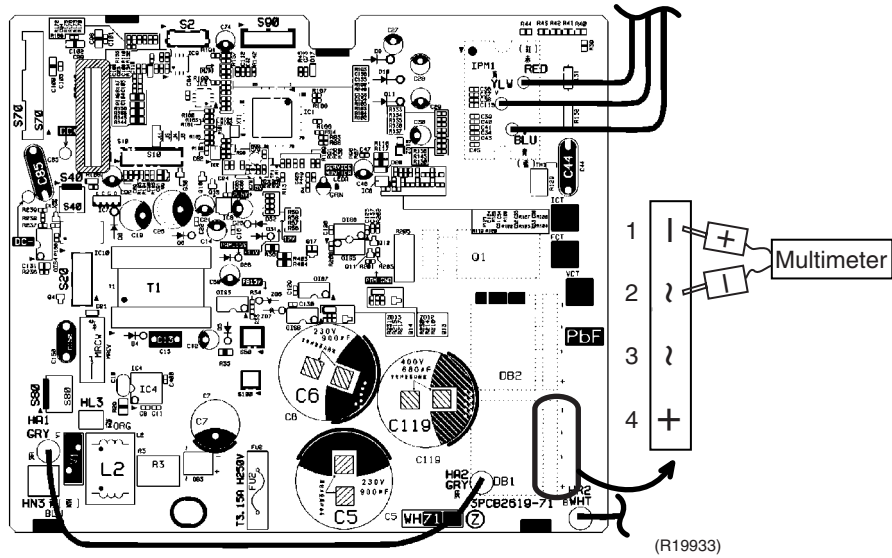

50 class

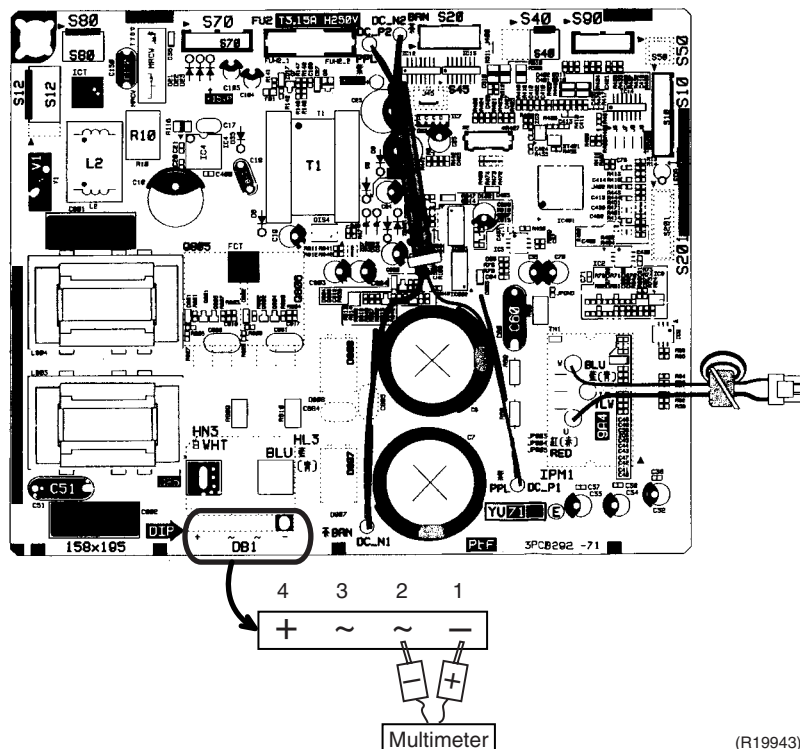

5.13 Power Module Check

Check No.22



Note: Check to make sure that the voltage between (+) and (-) of the diode bridge or the power module is approximately 0 V before checking.

- Disconnect the compressor harness connector from the outdoor unit PCB. To disengage the connector, press the protrusion on the connector.
- Follow the procedure below to measure resistance between the (+) or (-) terminal of the diode bridge or the power module, and the U, V, or W terminal of the compressor with a multimeter. Evaluate the measurement results referring to the following table.

Negative (-) terminal of multimeter (positive terminal (+) for digital multimeter)	Diode bridge (+) or Power module (+)	UVW	Diode bridge (-) or Power module (-)	UVW
Positive (+) terminal of multimeter (negative terminal (-) for digital multimeter)	UVW	Power module (+) or Diode bridge (+)	UVW	Power module (-) or Diode bridge (-)
Resistance is OK.	several kΩ ~ several MΩ			
Resistance is NG.	0 Ω or ∞			

20/25/35 class

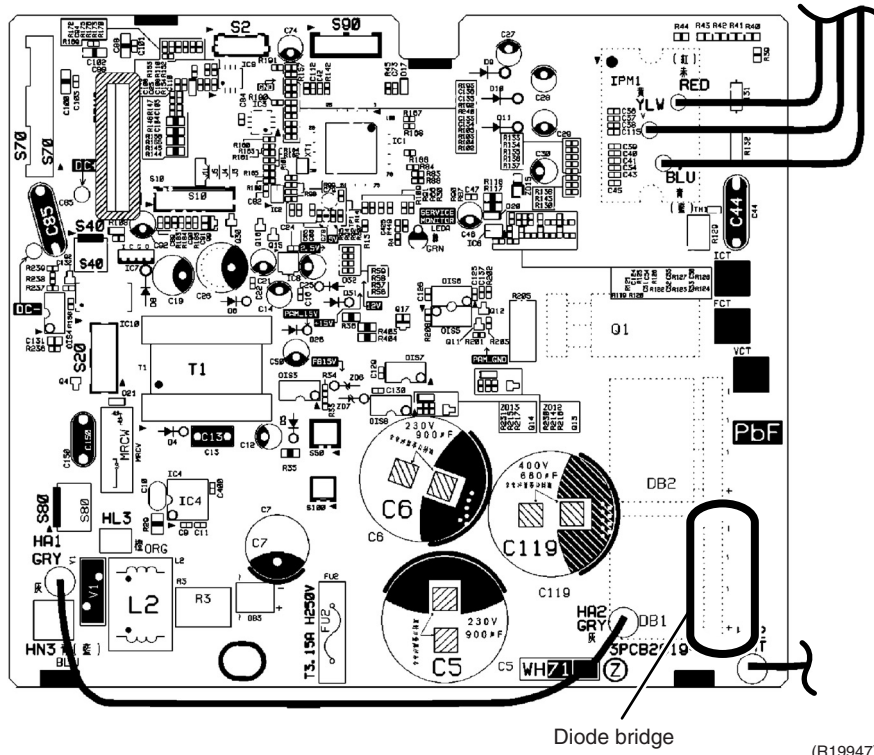

50 class

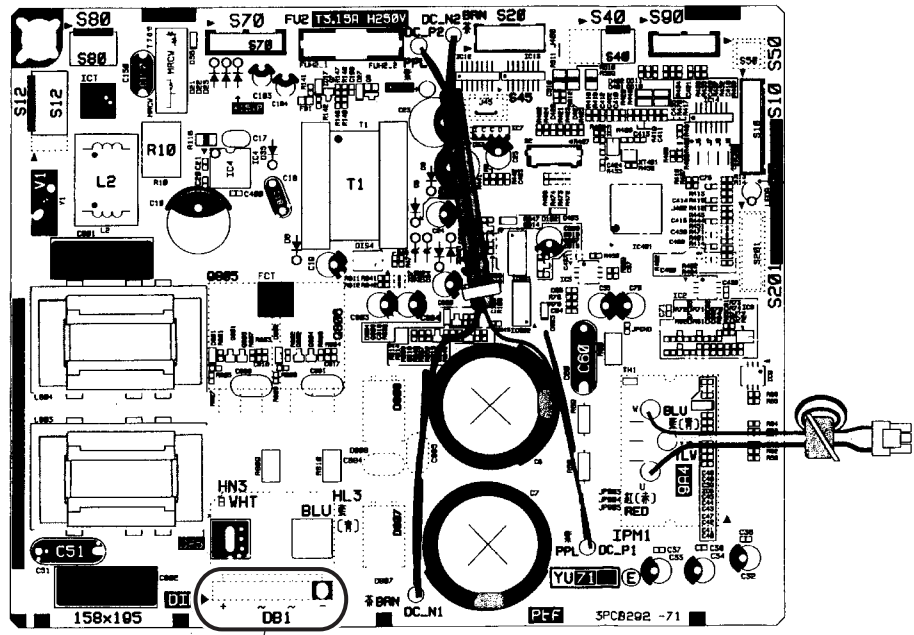

Diode bridge

(R19944)

Part 7

Trial Operation and Field Settings

1. Tips for Servicing	104
1.1 Pump Down Operation	104
1.2 Forced Cooling Operation	104
2. Trial Operation	106
3. Field Settings	107
3.1 When 2 Units are installed in 1 Room	107
3.2 Model Type Setting	107
3.3 Standby Electricity Saving	108
3.4 Jumper Settings	109
4. Silicon Grease on Power Transistor / Diode Bridge	110

1. Tips for Servicing

1.1 Pump Down Operation

Outline

In order to protect the environment, be sure to conduct pump down operation when relocating or disposing of the unit.

Detail

- 1) Remove the valve caps from the liquid stop valve and the gas stop valve.
- 2) Carry out forced cooling operation.
- 3) After 5 to 10 minutes, close the liquid stop valve with a hexagonal wrench.
- 4) After 2 to 3 minutes, close the gas stop valve and stop the forced cooling operation.

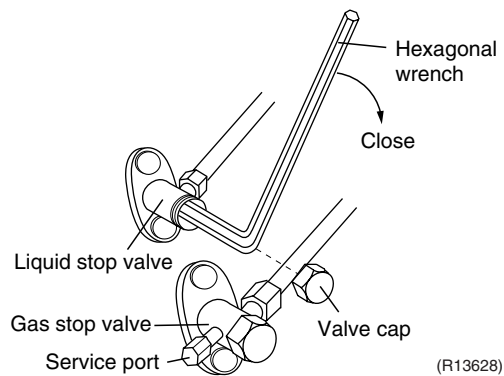

Refer to forced cooling operation below.

1.2 Forced Cooling Operation

Item	Forced Cooling
Conditions	The forced cooling operation is allowed when both of the following conditions are met. 1) The outdoor unit is not abnormal and not in the 3-minute standby mode. 2) The outdoor unit is not operating.
Start	The forced cooling operation starts when any of the following conditions are fulfilled. 1) Press the forced cooling operation ON/OFF button (S1W) on the indoor unit for 5 seconds. 2) Press the forced cooling operation ON/OFF button (SW1) on the outdoor unit within around 3 minutes after power is supplied with standby electricity saving function turned off.
Command frequency	20/25/35 class: 58 Hz 50 class: 66 Hz
End	The forced cooling operation ends when any of the following conditions are fulfilled. 1) The operation ends automatically after 15 minutes. 2) Press the forced cooling operation ON/OFF button (S1W) on the indoor unit again. 3) Press the ON/OFF button on the remote controller. 4) Press the forced cooling operation ON/OFF button (SW1) on the outdoor unit.
Others	Protection functions have priority over all other functions during forced cooling operation.

Indoor Unit

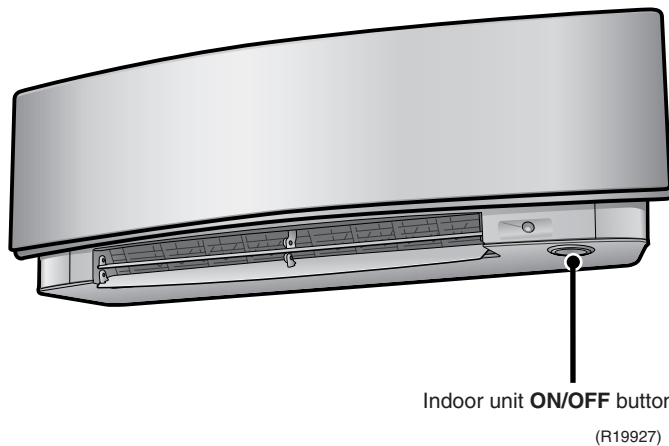

Outdoor Unit: 20/25/35 class

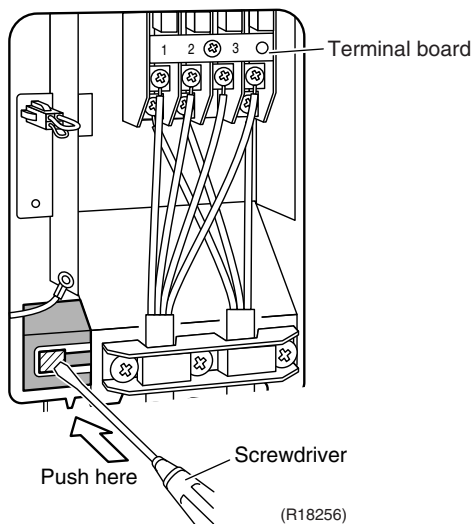

Outdoor Unit: 50 class

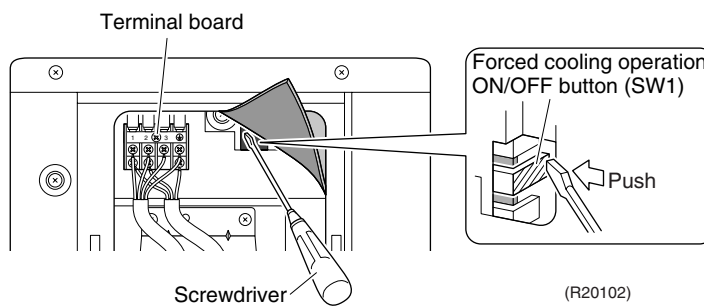

Caution

When pressing the button on the outdoor unit, do not touch the terminal board. It has a high voltage and may cause electric shock.

2. Trial Operation

Outline

Carry out the trial operation in accordance with the operation manual to ensure that all functions and parts, such as flap movement, are working properly.

Trial operation should be carried out in either cooling or heating operation.

Detail

1. Measure the power supply voltage and make sure that it falls within the specified range.
2. In cooling operation, select the lowest programmable temperature (18°C); in heating operation, select the highest programmable temperature (30°C).
 - ♦ Trial operation may be disabled in either operation mode depending on the room temperature.
 - ♦ After trial operation is complete, set the temperature to a normal level (26°C ~ 28°C in cooling, 20°C ~ 24°C in heating operation).
 - ♦ For protection, the system does not start for 3 minutes after it is turned off.

ARC466 Series

- (1) Press the **On/Off** button to turn on the system.
- (2) Press the center of the **Temp** button and the **Mode** button at the same time.
- (3) Select ? (trial operation) with the **Temp ▲** or **Temp ▼** button.
- (4) Press the **Mode** button to start the trial operation.
- (5) Press the **Mode** button and select operation mode.
- (6) Trial operation terminates in approx. 30 minutes and switches into normal mode. To quit trial operation, press the **On/Off** button.

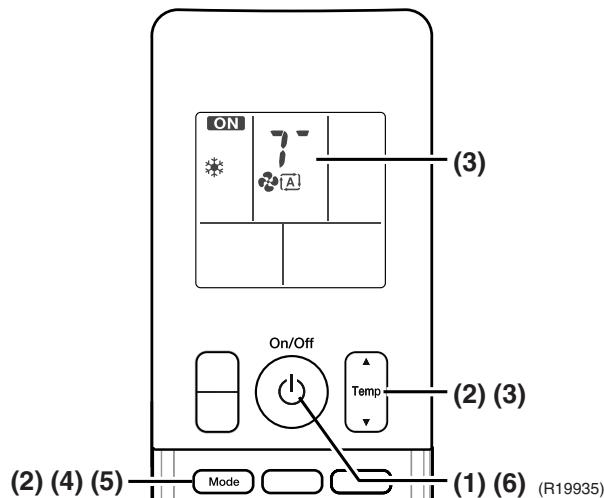

3. Field Settings

3.1 When 2 Units are installed in 1 Room

Outline

When 2 indoor units are installed in 1 room, 1 of the 2 indoor units and the corresponding wireless remote controller can be set for different addresses. Both the indoor unit PCB and the wireless remote controller need alteration.

Indoor Unit PCB

- Cut the address setting jumper JA on the control PCB.

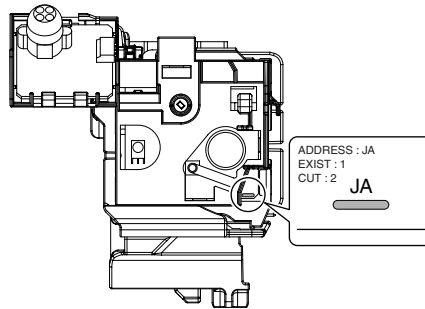

(R19936)



Caution

Replace the PCB if you accidentally cut a wrong jumper.

Jumpers are necessary for electronic circuit. Improper operation may occur if you cut any of them.

Wireless Remote Controller

- Cut the address setting jumper.
- **Replace the remote controller if you cut the jumper on the left side.**
The heating operation will not be available when the jumper on the left side is cut.

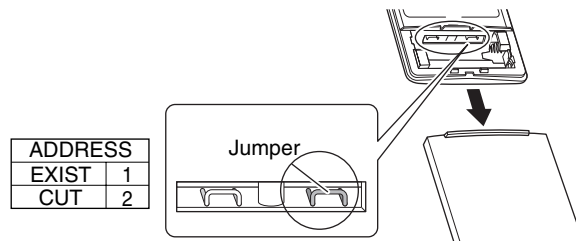

* Do not cut the left jumper.

(R18416)

3.2 Model Type Setting

- This remote controller is common to the heat pump model and cooling only model.
- **Replace the remote controller if you cut the jumper on the left side.**
The heating operation will not be available when the jumper on the left side is cut.

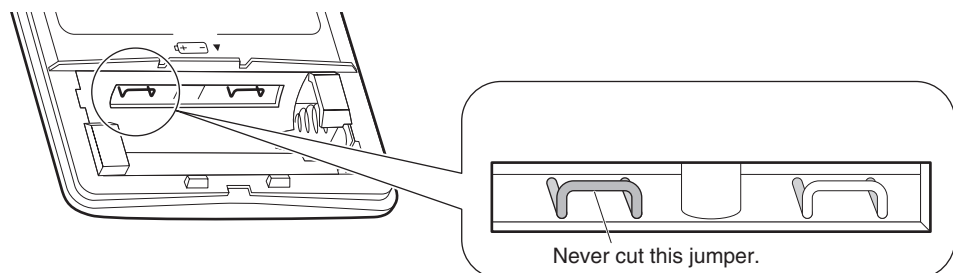

(R18451)

3.3 Standby Electricity Saving

Outline

This function turns power supply OFF to the outdoor unit and sets the indoor unit into standby electricity saving mode, thus reducing the power consumption of the air conditioner.

Detail

Following procedure is required for turning ON the function.

1. Check that the main power supply is turned OFF. Turn OFF if it has not been turned OFF.
2. Remove the stop valve cover.
3. Disconnect the selective connector for standby electricity saving.
4. Turn ON the main power supply.

20/25/35 class

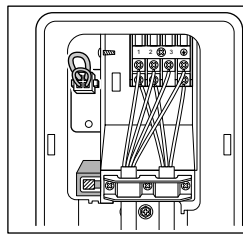

Function OFF
(factory set)

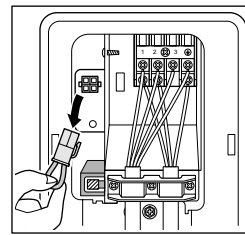

Function ON

(R18981)

50 class

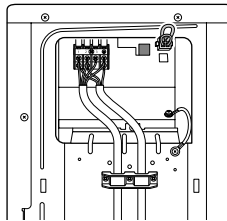

Function OFF
(factory set)

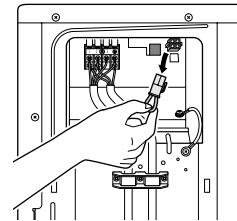

Function ON

(R18926)



Caution

Before connecting or disconnecting the selective connector for standby electricity saving, make sure that the main power supply is turned OFF.

3.4 Jumper Settings

Indoor Unit

Function	Jumper	When connected (factory setting)	When cut
Fan speed setting when compressor stops for thermostat OFF. (effective only in cooling operation)	JB	The fan stops.	Fan speed setting ; Remote controller setting
Power failure recovery function	JC	Auto-restart	The unit does not resume operation after recovering from a power failure. Timer settings are cleared.



For the location of the jumper, refer to page 9.

Outdoor Unit

Function	Jumper	When connected (factory setting)	When cut
Improvement of defrost performance	20/25/35 class → J5 50 class → J8	Standard control	Reinforced control (Ex: The frequency increases, the duration time of defrost lengthens.)



For the location of the jumper, refer to page 11, 13.



Caution

Replace the PCB if you accidentally cut a wrong jumper.

Jumpers are necessary for electronic circuit. Improper operation may occur if you cut any of them.

4. Silicon Grease on Power Transistor / Diode Bridge

Outline

Apply the specified silicon grease to the heat radiation part of a power transistor / diode bridge when you replace an outdoor unit PCB. The silicon grease encourages the heat radiation of a power transistor / diode bridge.

Detail

1. Wipe off the old silicon grease completely.
2. Apply the silicon grease evenly. See the illustrations below for examples of application.
3. Tighten the screws of the power transistor / diode bridge.
4. Make sure that the heat radiation parts are firmly contacted to the radiation fin.

Note: Smoke emission may be caused by bad heat radiation when the silicon grease is not appropriately applied.

- OK: Evenly applied

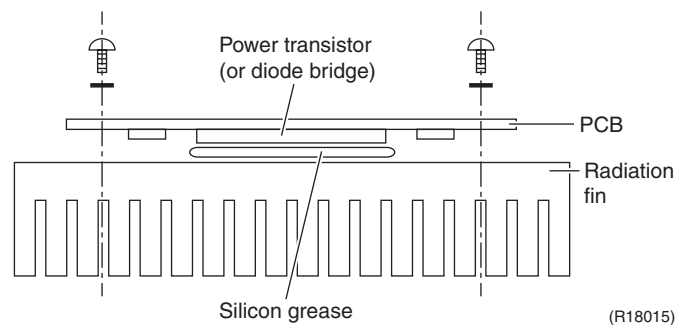

- NG: Not evenly applied

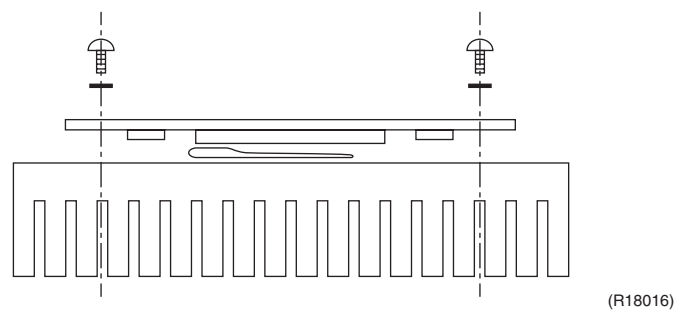

- NG: Foreign matter is stuck.

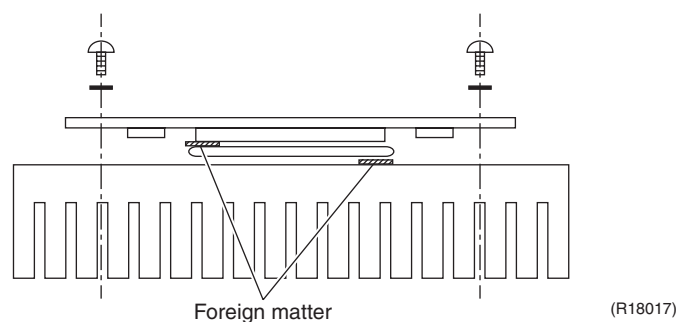

Part 8

Appendix

1. Piping Diagrams.....	112
1.1 Indoor Unit.....	112
1.2 Outdoor Unit.....	112
2. Wiring Diagrams.....	114
2.1 Indoor Unit.....	114
2.2 Outdoor Unit.....	114

1. Piping Diagrams

1.1 Indoor Unit

FTXG20/25/35LV1BW(S)

FTXG50LV1BW(S)

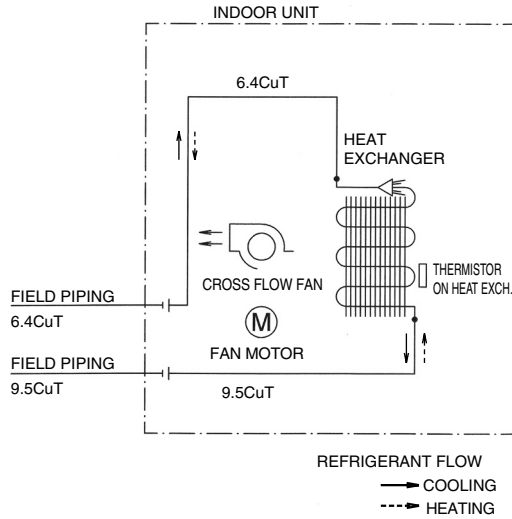

4D085645

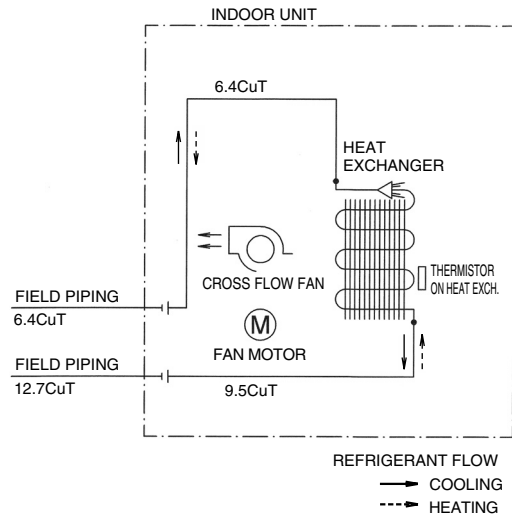

4D085834

1.2 Outdoor Unit

RXG20/25/35L2V1B

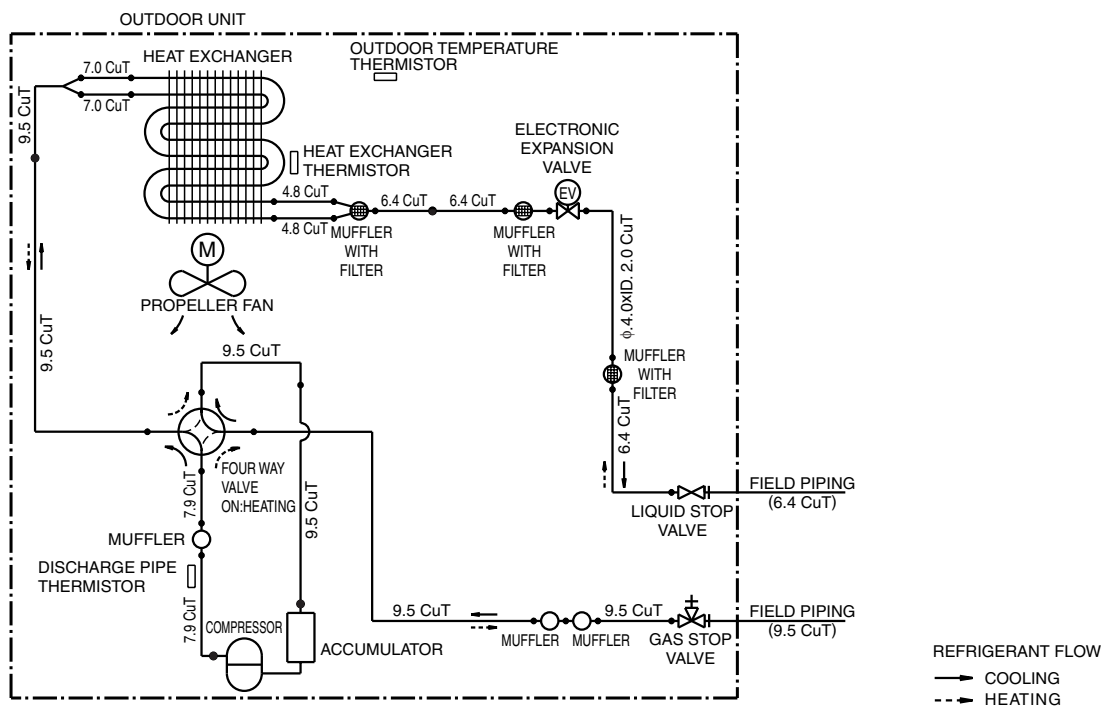

3D059586T

RXG50L2V1B

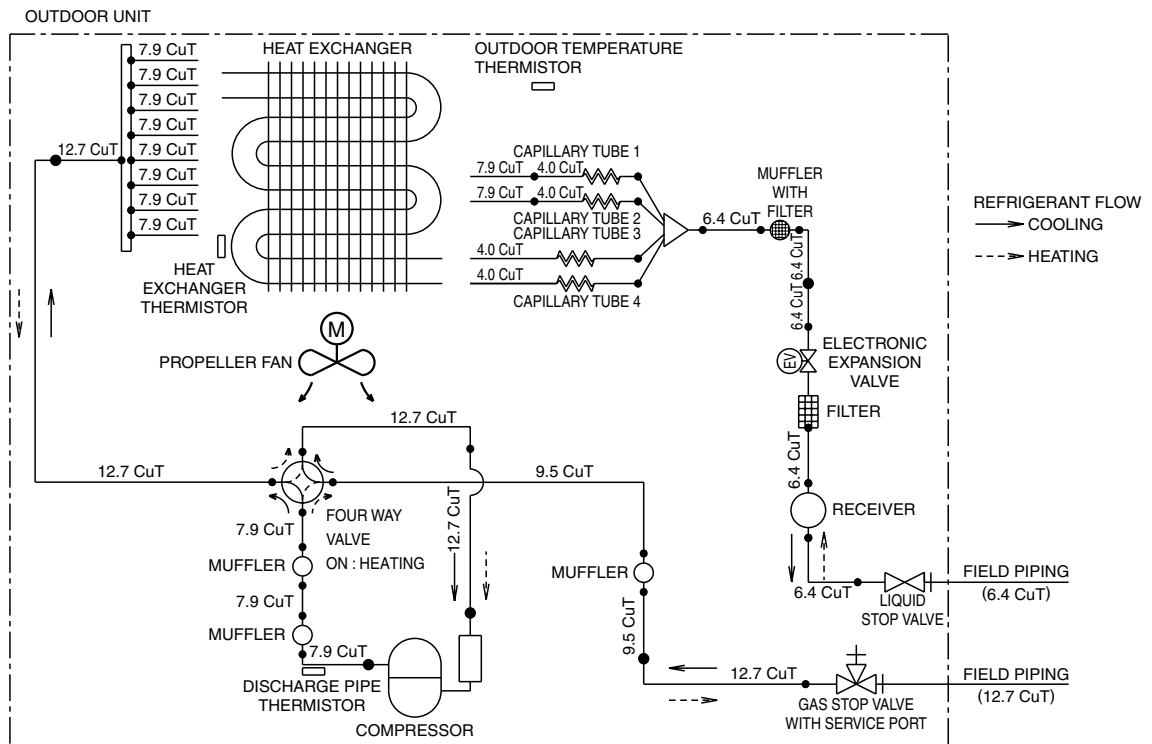

3D080605C

2. Wiring Diagrams

2.1 Indoor Unit

FTXG20/25/35/50LV1BW(S)

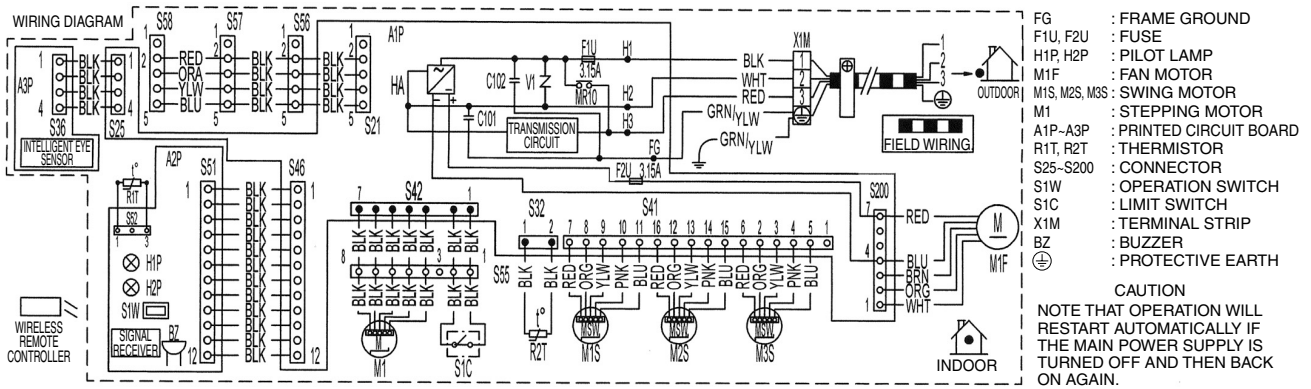

3D085644

2.2 Outdoor Unit

RXG20/25/35L2V1B

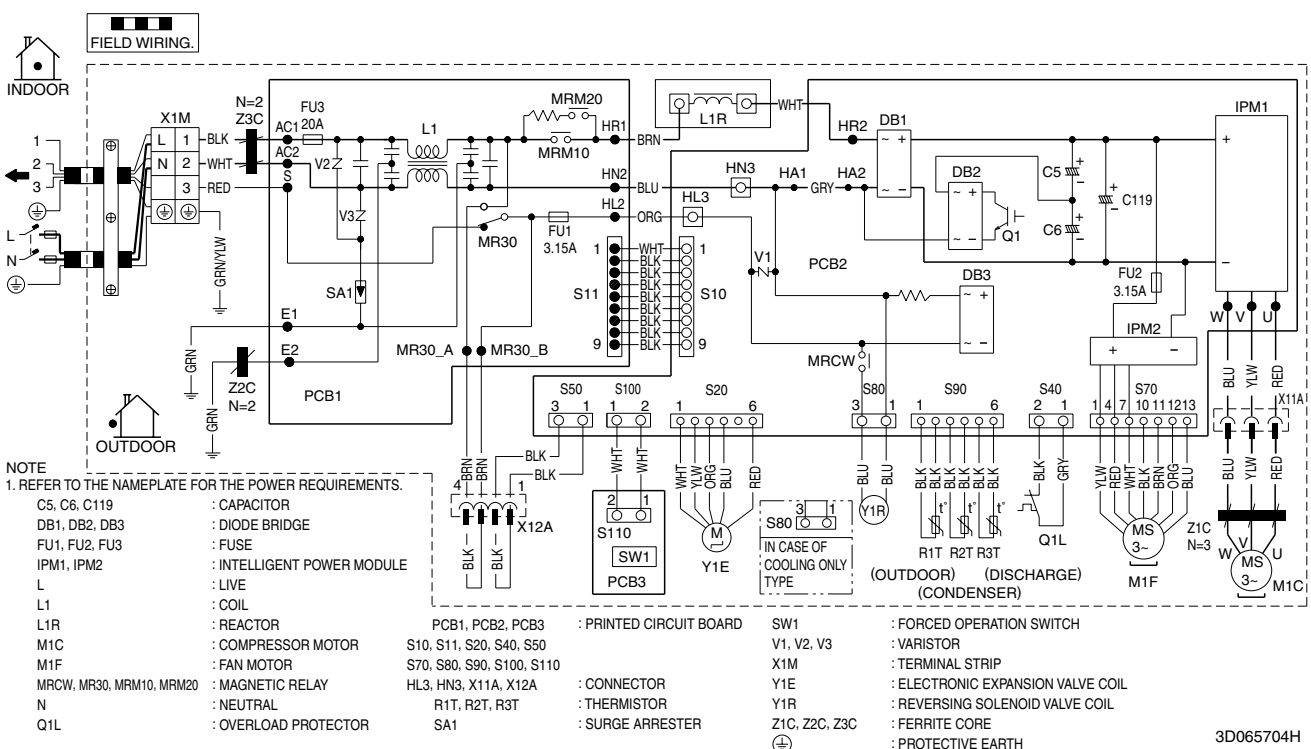

3D065704H

RXG50L2V1B

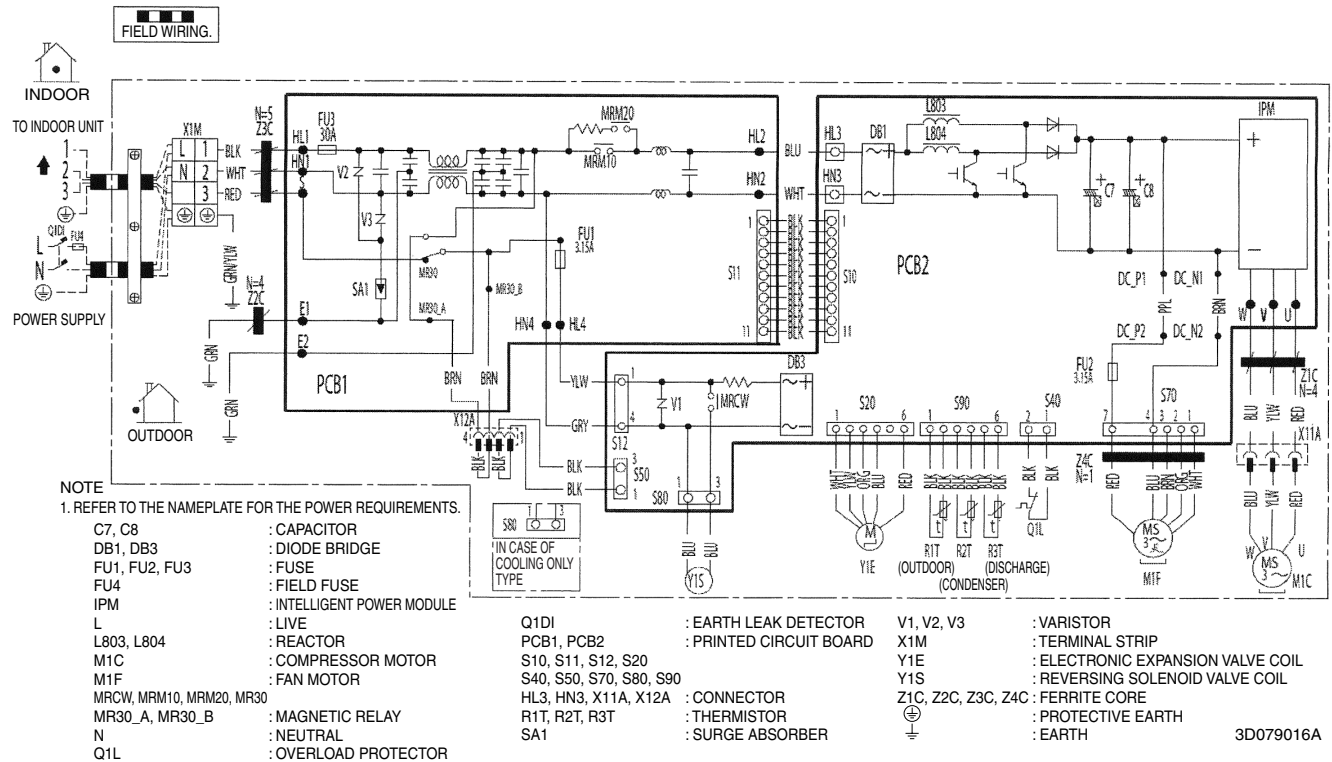

Revision History

Month / Year	Version	Revised contents
03 / 2014	SIBE041401E	First edition

Warning



- Daikin products are manufactured for export to numerous countries throughout the world. Prior to purchase, please confirm with your local authorised importer, distributor and/or retailer whether this product conforms to the applicable standards, and is suitable for use, in the region where the product will be used. This statement does not purport to exclude, restrict or modify the application of any local legislation.
- Ask a qualified installer or contractor to install this product. Do not try to install the product yourself. Improper installation can result in water or refrigerant leakage, electrical shock, fire or explosion.
- Use only those parts and accessories supplied or specified by Daikin. Ask a qualified installer or contractor to install those parts and accessories. Use of unauthorised parts and accessories or improper installation of parts and accessories can result in water or refrigerant leakage, electrical shock, fire or explosion.
- Read the User's Manual carefully before using this product. The User's Manual provides important safety instructions and warnings. Be sure to follow these instructions and warnings.

If you have any enquiries, please contact your local importer, distributor and/or retailer.

Cautions on product corrosion

1. Air conditioners should not be installed in areas where corrosive gases, such as acid gas or alkaline gas, are produced.
2. If the outdoor unit is to be installed close to the sea shore, direct exposure to the sea breeze should be avoided. If you need to install the outdoor unit close to the sea shore, contact your local distributor.

Dealer

DAIKIN INDUSTRIES, LTD.

Head Office:
Umeda Center Bldg., 2-4-12, Nakazaki-Nishi,
Kita-ku, Osaka, 530-8323 Japan

Tokyo Office:
JR Shinagawa East Bldg., 2-18-1, Konan,
Minato-ku, Tokyo, 108-0075 Japan

<http://www.daikin.com>

©All rights reserved